

OPERATOR'S MANUAL

GYROTEDDER

TD1316





Suggest:

For more complete manuals. Please go to the home page.

<https://www.ebooklibonline.com>

If the above button click is invalid. Please download this document first, and then click the above link to download the complete manual.

Thank you so much for reading

CONTENTS

■ Dear Owner	1
■ Contents	2
■ Identification of the machine	4
Front view (transport position).....	4
Front view (working position).....	4
Model identification plate.....	5
■ Safety	6
Description of symbols used in this document.....	6
Safety instructions.....	7
Location and description of safety decals on the machine.....	15
■ Machine specifications.....	21
Description and glossary	21
Technical specifications.....	22
Sound levels.....	22
■ Putting into service.....	23
Description of control elements	23
Coupling and uncoupling.....	23
■ Instructions for transport.....	31
Putting the machine into transport position	31
Conformity with the road regulations	33

<https://www.ebooklibonline.com>

Hello dear friend!

Thank you very much for reading.

Enter the link into your browser.

The full manual is available for immediate download.

<https://www.ebooklibonline.com>

■ Instructions for work.....	34
Putting the machine into work position	34
Adjustments in working position	36
Machine use	37
■ Maintenance and storage	41
Frequency chart.....	41
Lubrication	42
Maintenance	46
Storage	48

IDENTIFICATION OF THE MACHINE

1. Front view (transport position)

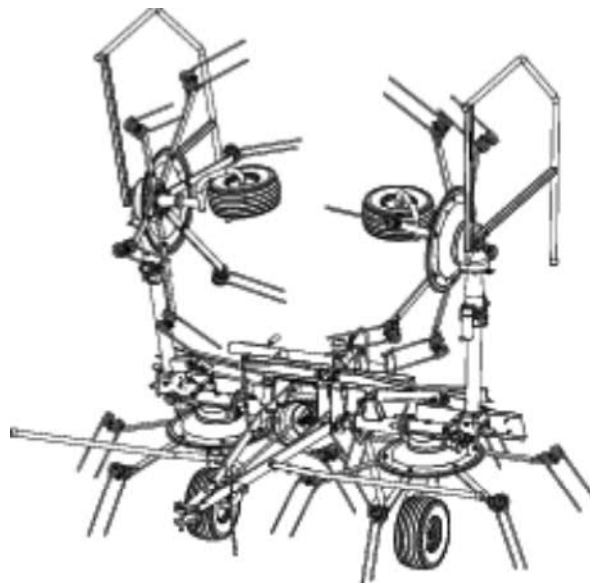

2. Front view (working position)

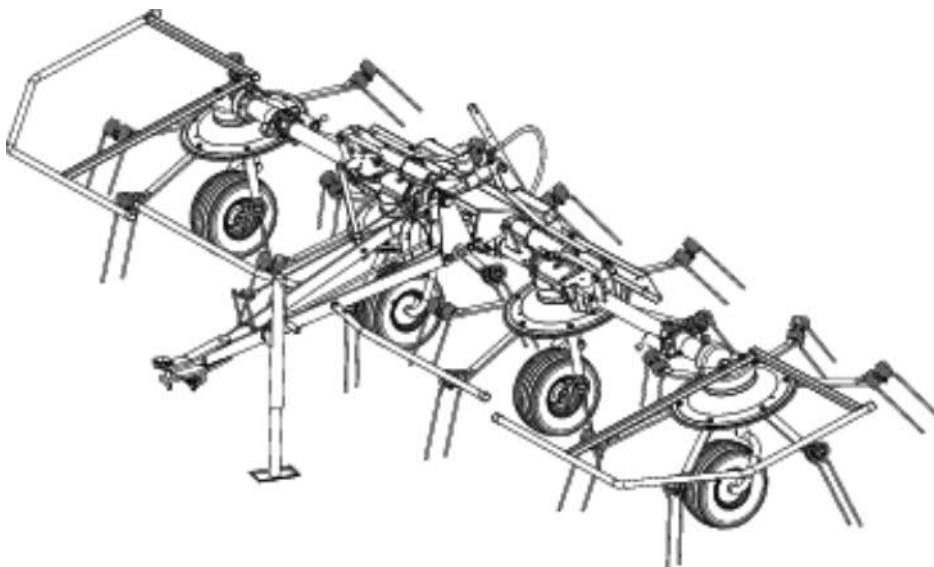

3. Model identification plate

Please write below the type and serial number of the machine. This information is to be indicated to the dealer for all spare parts orders.

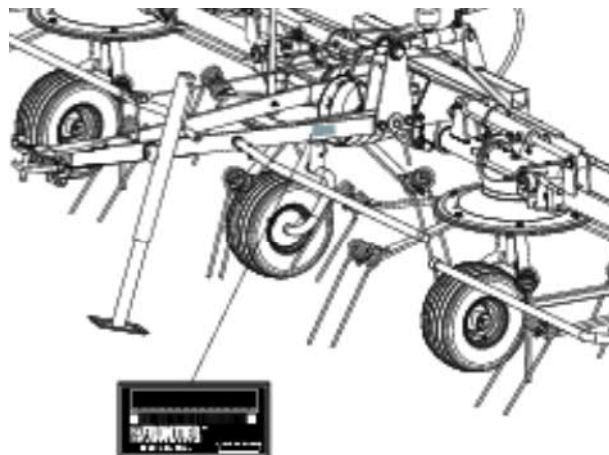

Type: TD1316

No:



4. Optional equipment

- Kit no. KN1116440: DUPLEX gearbox.
- Kit no. KN1116310: Tine arm deflectors.

SAFETY

1. Description of symbols used in this document

This symbol indicates a potentially hazardous situation that if not avoided, could result in serious bodily injury.



This symbol is used to identify special instructions or procedures which, if not followed strictly, could result in machinery damage.



This symbol is used to communicate technical information of particular interest.



<https://www.ebooklibonline.com>

Hello dear friend!

Thank you very much for reading.

Enter the link into your browser.

The full manual is available for immediate download.

<https://www.ebooklibonline.com>