

OPERATOR'S MANUAL

OFFSET AGRICULTURAL DISKS

DH5308-DH5310

DH5312-DH5314-DH5316



FRONTIER
EQUIPMENT™



Suggest:

For more complete manuals. Please go to the home page.

<https://www.ebooklibonline.com>

If the above button click is invalid. Please download this document first, and then click the above link to download the complete manual.

Thank you so much for reading

Introduction

READ THIS MANUAL carefully to learn how to operate and service your machine correctly. Failure to do so could result in personal injury or equipment damage. This manual and safety signs on your machine may be ordered from your John Deere dealer.

THIS MANUAL SHOULD BE CONSIDERED a permanent part of your machine and should remain with the machine when you sell it.

MEASUREMENTS in this manual are given in customary U.S. units. Only use the correct replacement parts and fasteners.

RIGHT-HAND AND LEFT-HAND sides are determined by facing in the direction the implement will travel when going forward.

WRITE DOWN PRODUCT IDENTIFICATION NUMBERS. Accurately record all the numbers to help in tracing the machine should it be stolen. Your John Deere dealer also needs these numbers when you order parts. File the identification numbers in a secure place away from the machine.

WARRANTY coverage is provided by John Deere according to the terms of the Construction, Utility, and Forestry Products Standard Warranty Statement. Carefully read the warranty statement on the back of your original purchase order for details on coverage and limitations of this warranty.

This warranty provides you the assurance that Frontier will back its products where defects appear within the warranty period. In some circumstances, Frontier also provides field improvements, often without charge to the customer, even if the product is out of warranty. Should the equipment be abused or modified to change its performance beyond the original factory specifications, or if the equipment is used for a purpose other than that which it was designed for, the warranty will become void and field improvements may be denied.

THE TIRE MANUFACTURERS warranty is separate and apart from the equipment warranty and may not apply outside the U.S.

<https://www.ebooklibonline.com>

Hello dear friend!

Thank you very much for reading.

Enter the link into your browser.

The full manual is available for immediate download.

<https://www.ebooklibonline.com>

Contents

Introduction	1
General Arrangement (Models DH5308 / DH5310)	4
General Arrangement (Models DH5312 / DH5314 / DH5316)	5
General Information	6
Pre-Delivery Checklist	7
Delivery Checklist	7
After Sale Checklist	8
Daily Checklist	8
Seasonal Checklist	8
Decal Identification and Placement	9
Safety First	10
Attaching the Disc to the Tractor	11
Transporting the Disc	11
Adjusting the Transport Levelling Control Arm	12
Transport and Operating Safety	13
Operating the Disk	
General Operating Guidelines	14
Reposition the Hitch	14
Change the Gang Angles	15
Adjust the Levelling Control Arm	16
Service and Maintenance Safety	17
Lubricate the Disk	18
Check the Oil-Bath Bearings	19
Adjusting the Scrapers	19
Repack and Pre-Load Wheel Hub Bearings	20
Fluid and Fastener Specifications	
Disc Gang Assembly Axles	21
Fastener Torque Values	21
Oil-Bath Bearing Oil	21
Tire and Wheel Service	21
Keep Gang Assemblies Tight	22
Assembly Safety	23
Assemble the Disk	24
Disk Gang Assembly Procedure	32
Detailed Parts Diagrams	33
Hitch and Bridle Assembly (Models DH5308 / DH5310)	34
Hitch and Bridle Assembly (Models DH5312 / DH5314 / DH5316)	35
Frame and Transport Assembly (Models DH5308 / DH5310)	36
Frame and Transport Assembly (Models DH5312 / DH5314 / DH5316)	37
Control Arm Assembly	38
Gang Bars and Scrapers	39

Gang Assembly	40
Oil-Bath Bearing Assembly	41
Hydraulic Cylinder (CTD)	42
Hydraulic Cylinder (RAM)	43
8-Bolt Hub	44
Tire and Wheel Assembly	45
Light Kit	46
Decals, Reflectors and Logos	47
Specifications	48
Storage	49

PRODUCT GENERAL ARRANGEMENT AND IDENTIFICATION MODELS DH5308 / DH5310

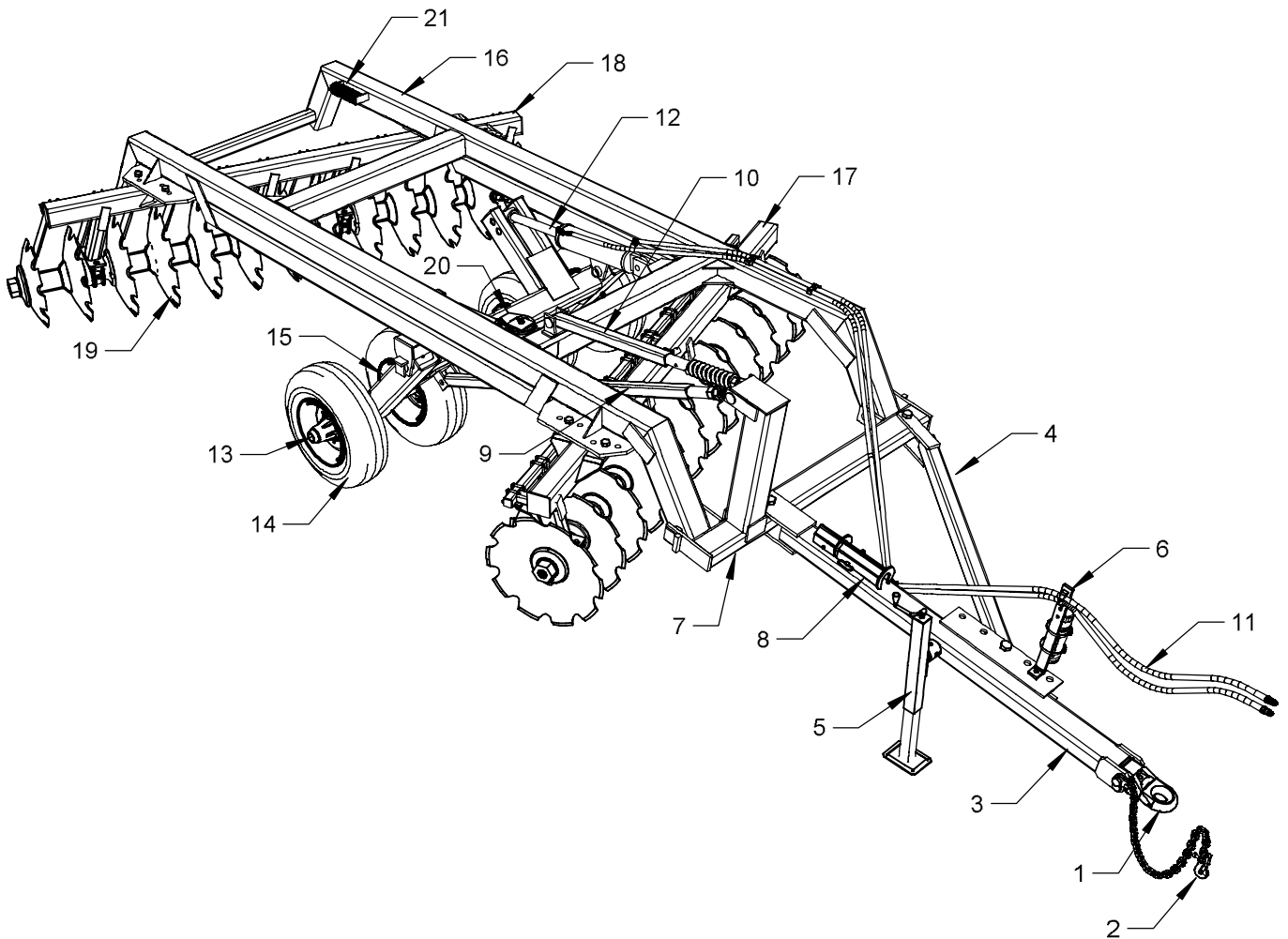

- | | |
|-------------------------------------|-----------------------------------|
| 1 Hitch Tongue | 11 Hydraulic Hose Kit |
| 2 Safety Chain | 12 Hydraulic Cylinder |
| 3 Hitch | 13 Hub Assembly |
| 4 Side Arm | 14 Tire and Wheel Assembly |
| 5 Jack | 15 Transport Assembly |
| 6 Hose Holder & Manual Cannister | 16 Main Frame |
| 7 Bridle | 17 Front Gang Bar c/w Scraper Bar |
| 8 Transport Stay (Storage Location) | 18 Rear Gang Bar c/w Scraper Bar |
| 9 Transport Control Arm | 19 Disc Gang Assembly |
| 10 Leveling Control Arm | 20 Gang Wrenches |
| | 21 Depth Control Segments |

PRODUCT GENERAL ARRANGEMENT AND IDENTIFICATION MODELS DH5312 / DH5314 / DH5316

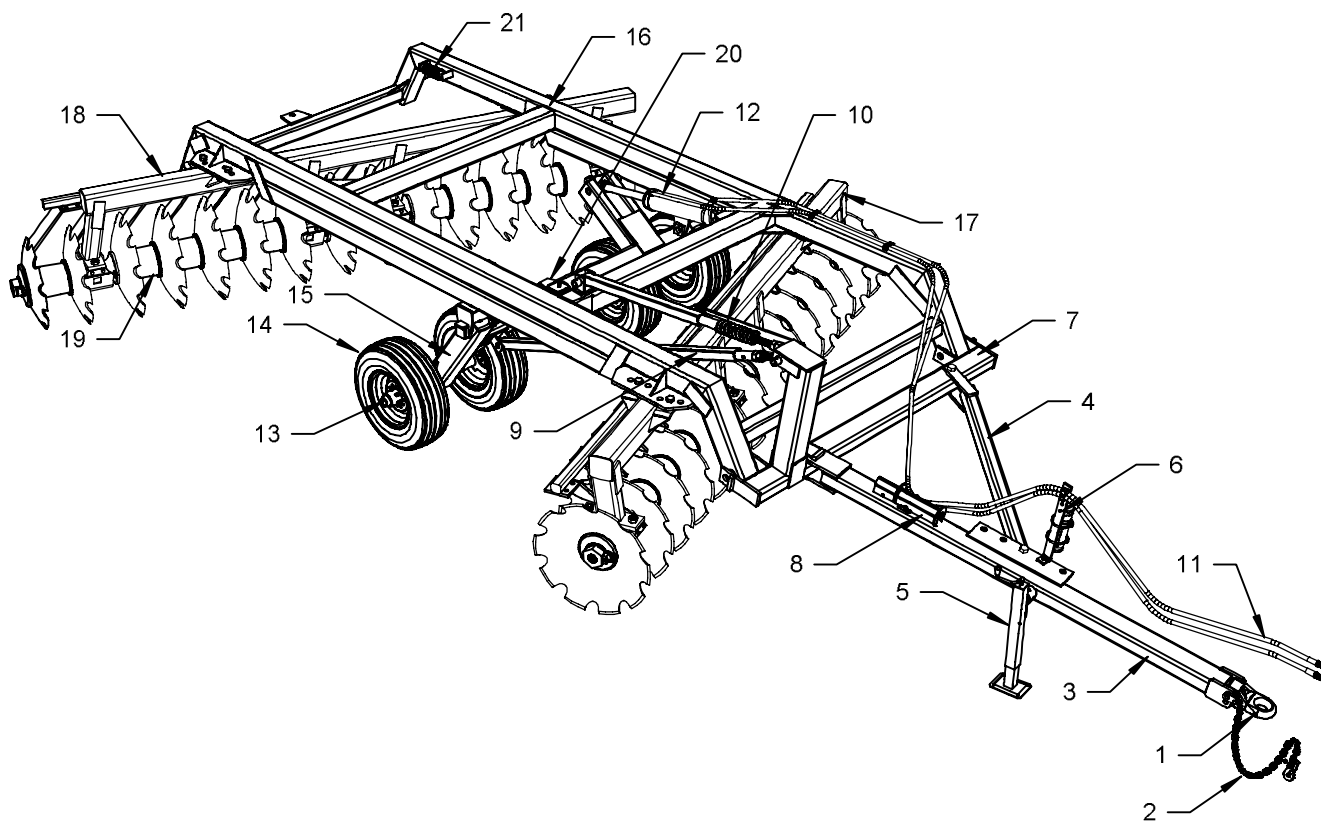

- | | | | |
|----|-----------------------------------|----|--------------------------------|
| 1 | Hitch Tongue | 11 | Hydraulic Hose Kit |
| 2 | Safety Chain | 12 | Hydraulic Cylinder |
| 3 | Hitch | 13 | Hub Assembly |
| 4 | Side Arm | 14 | Tire and Wheel Assembly |
| 5 | Jack | 15 | Transport Assembly |
| 6 | Hose Holder & Manual Cannister | 16 | Main Frame |
| 7 | Bridle | 17 | Front Gang Bar c/w Scraper Bar |
| 8 | Transport Stay (Storage Location) | 18 | Rear Gang Bar c/w Scraper Bar |
| 9 | Transport Control Arm | 19 | Disc Gang Assembly |
| 10 | Leveling Control Arm | 20 | Gang Wrenches |
| | | 21 | Depth Control Segments |

<https://www.ebooklibonline.com>

Hello dear friend!

Thank you very much for reading.

Enter the link into your browser.

The full manual is available for immediate download.

<https://www.ebooklibonline.com>