

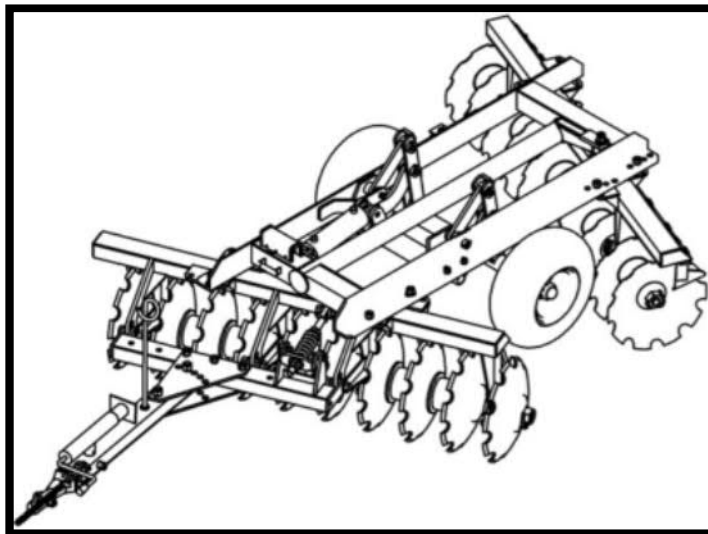

## ASSEMBLY & OPERATING INSTRUCTIONS



**Models**  
DH4307, DH4309, DH4311,  
DH4413, DH4315, DH4415

## WHEEL - TYPE OFFSET DISK HARROWS

FORM NO. 5RPMAN329AO

PUBLISHED DATE 06-08



**Suggest:**

**For more complete manuals. Please go to the home page.**

**<https://www.ebooklibonline.com>**

**If the above button click is invalid. Please download this document first, and then click the above link to download the complete manual.**

**Thank you so much for reading**

# Contents

<b>Product Identification</b> .....	6
<b>General Information</b> .....	7
<b>Checklists</b> .....	8
Pre-delivery Checklist.....	8
Delivery Checklist.....	9
After-Sale Checklist.....	10
Each Morning of Operation Checklist.....	10
Before Each Season Checklist.....	10
<b>Safety Signs</b> .....	12
<b>Safety</b> .....	14
Recognize Safety Information.....	14
Understand Signal Words.....	14
Follow Safety Instructions.....	14
Use Seat Belt Properly.....	15
Operate Safely.....	15
Keep Riders Off Machine.....	16
Prepare for Emergencies.....	16
Wear Protective Clothing.....	16
Protect Against Noise.....	16
Use Safety Lights and Devices.....	17
Use A Safety Chain.....	17
Transport Safely.....	18
Tow Loads Safely.....	19
Practice Safe Maintenance.....	20
Remove Paint Before Welding or Heating.....	21
Avoid Heating Near Pressurized Fluid Lines.....	21
Avoid High-Pressure Fluids.....	22
Avoid Harmful Asbestos Dust.....	22
Store Attachments Safely.....	23
Dispose of Waste Properly.....	23
<b>Preparing the Tractor</b> .....	24
Positing Drawbar.....	24
<b>Preparing the Disk</b> .....	25
Checking and Lubricating Disk.....	25
Adjusting Rigid Scrapers.....	25
Notes.....	26
<b>Attaching and Detaching</b> .....	27
Attaching Disk to Tractor.....	27
Attaching Safety Chain to Tractor.....	27
Attaching Hydraulic Hoses.....	27
Attaching Warning Light Plug.....	28
Detaching Disk From Tractor.....	29
Checking Transport Control.....	30
Checking Leveling Adjustment.....	31
Notes.....	32

**<https://www.ebooklibonline.com>**

Hello dear friend!

Thank you very much for reading.

Enter the link into your browser.

The full manual is available for immediate download.

**<https://www.ebooklibonline.com>**

# Contents

<b>Transporting Machine</b> .....	33
Caution: Safety Guidelines.....	33
Positioning Tractor Drawbar For Transport (Four Wheel Drive Tractors).....	34
Positioning Jack for Transport.....	34
Attach Safety Chain to Tractor.....	34
Install Transport Lock.....	35
Attaching Warning Light Plug.....	35
Transporting the Machine.....	35
<b>Operating the Machine</b> .....	36
Caution: Safety Guidelines.....	36
Guidelines for Use.....	37
Tighten Hardware.....	37
Operating Speed.....	37
Hydraulic Control.....	38
Scraper Adjustment.....	38
Preparing to Operate in the Field.....	39
Set Depth of Penetration Control.....	39
Angling Front and Rear Gangs.....	40
Rear Gang Side Adjustment.....	41
Torsion Bar Adjustment.....	42
Offset Bar Height Adjustment.....	42
Leveling Front to Rear.....	42
Positioning Drawbar on Offset Bar to Reduce Tractor Side Draft.....	43
Adjusting Side Draft.....	44
Adjusting Uneven Gang Penetration.....	45
Set Drawbar Angle.....	46
<b>Lubrication</b> .....	47
Lubricate Storage.....	47
Lubricate Gang Bearing.....	47
Lubricate Wheel Bearings.....	47
Lubricate Bell Crank Bearings.....	47
Lubricate Leveling Adjustment Spring.....	47
<b>Maintenance</b> .....	48
Caution: Safety Guidelines.....	48
Checking Wheel Bolts and Bearings.....	49
Repack Wheel Hub Bearings Annually.....	49
Gang Bearings.....	50
Disk Gangs.....	50
Hydraulic Hoses.....	50
Fasteners.....	50
Removing Hydraulic Cylinders.....	51
Bleeding Transport Cylinder.....	51
Servicing Disk Gangs.....	52
Assembling Disk Spacers.....	52
Gang Axle Nut Wrenches.....	52

## Contents

Tighten Gang Axle Nuts.....	53
Attaching Disk Gangs to Standards.....	54
Service Tires Safely.....	55
Checking Tire Pressure.....	55
Tire Pressure Chart.....	56
<b>Storage</b> .....	57
Beginning of Season Maintenance.....	57
End of Season Maintenance.....	57
<b>Assembly</b> .....	58
Caution: Safety Guidelines.....	58
Check All Parts on Packing List.....	59
Step 1. Assembling Gangs.....	60
Step 2. Installing Gangs on Gang Carriers.....	61
Step 3. Installing Gang Carriers to Frame.....	61
Step 4. Installing Transport Assembly.....	61
Step 5. Installing Wheel Assemblies.....	62
Step 6. Installing Offset Bar and Leveling Spring Rod.....	62
Step 7. Installing Drawbar.....	63
Step 8. Attach Jack Assembly.....	63
Step 9. Adjusting the Scrapers.....	63
Step 10. Installing Hydraulic Control Groups.....	63
<b>Attachment Assembly</b> .....	64
Install Safety Chain.....	64
Bearing Wear Plates.....	64
Install Warning Lights.....	65
<b>Suggested Repair Parts (DH4307)</b> .....	66
<b>Suggested Repair Parts (DH4309)</b> .....	67
<b>Suggested Repair Parts (DH4311)</b> .....	68
<b>Suggested Repair Parts (DH4413)</b> .....	69
<b>Suggested Repair Parts (DH4315 and DH4415)</b> .....	70
<b>Specifications - All Models</b> .....	71-73

# Contents

## PRODUCT IDENTIFICATION

### Frontier Models DH4307, DH4309, DH4311, DH4413, DH4315 and DH4415 Wheel Type Offset Disk Harrows

- A-CLEVIS
- B-SAFETY CHAIN
- C-JACK
- D-DRAWBAR
- E-HOSE HOLDER
- F-DRAWBAR PLATE
- G-OFFSET BAR
- H-LEVELING SPRING
- I-DISK SPACER
- J-FRONT GANG ASSEMBLY
- K-TIRE & WHEEL ASSEMBLY
- L-FRONT GANG CARRIER
- M-BELL CRANK
- N-REAR GANG ASSEMBLY
- O-SCRAPER ASSEMBLY
- P-FRAME
- Q-REAR GANG CARRIER
- R-TRANSPORT ASSEMBLY
- S-HYDRAULIC CYLINDER

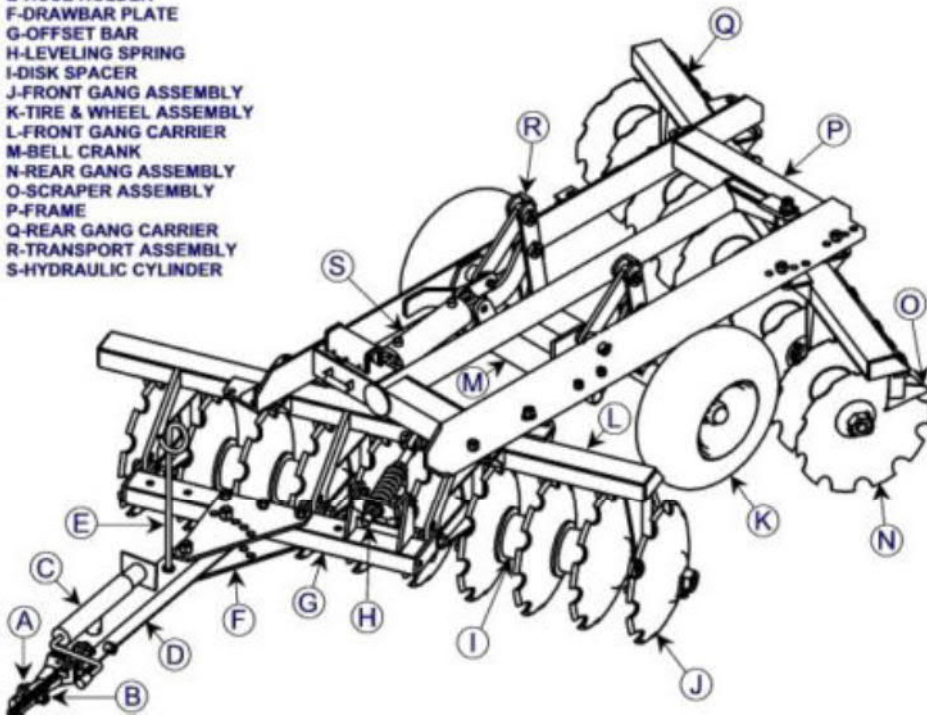

- A-CLEVIS
- B-SAFETY CHAIN
- C-DRAWBAR
- D-JACK
- E-HOSE HOLDER
- F-OFFSET BAR
- G-DRAWBAR PLATE
- H-GANG ASSEMBLY
- I-SCRAPER ASSEMBLY
- J-FRONT GANG CARRIER
- K-FRAME
- L-HYDRAULIC CYLINDER
- M-BELL CRANK
- N-WHEEL & TIRE ASSEMBLY
- O-GANG ASSEMBLY
- P-REAR GANG CARRIER
- Q-TRANSPORT ASSEMBLY
- R-LEVELING ASSEMBLY
- S-LEVELING SPRING

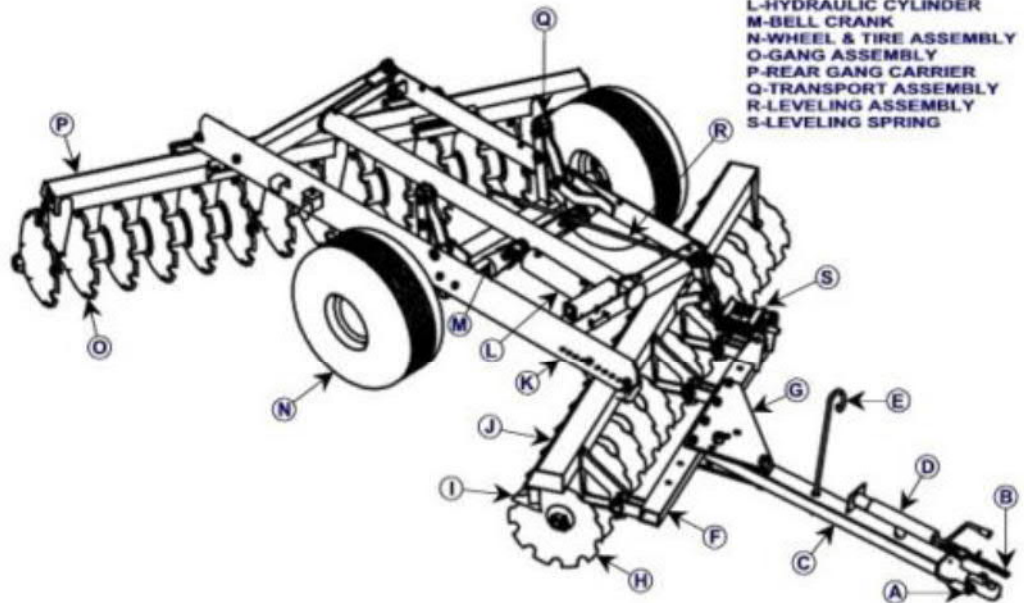

Thank you so much for reading.  
Please click the “Buy Now!”  
button below to download the  
complete manual.



After you pay.

You can download the most  
perfect and complete manual in  
the world immediately.

Our support email:

[ebooklibonline@outlook.com](mailto:ebooklibonline@outlook.com)

**<https://www.ebooklibonline.com>**

Hello dear friend!

Thank you very much for reading.

Enter the link into your browser.

The full manual is available for immediate download.

**<https://www.ebooklibonline.com>**