

CTS Combine

John Deere Harvester Works
OMH161695 Issue C7
(This manual replaces OMH159577 A7)

LITHO IN U.S.A.
ENGLISH

Safety

RECOGNIZE SAFETY INFORMATION

This is the safety-alert symbol. When you see this symbol on your machine or in this manual, be alert to the potential for personal injury.

Follow recommended precautions and safe operating practices.

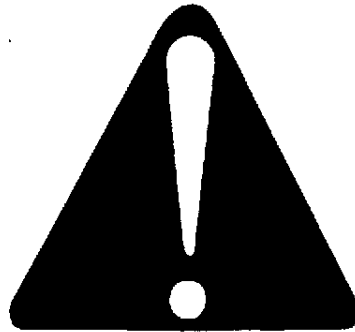

DX,ALERT -19-03MAR93

T81389 -UN-07DEC68

UNDERSTAND SIGNAL WORDS

A signal word—DANGER, WARNING, or CAUTION—is used with the safety-alert symbol. DANGER identifies the most serious hazards.

DANGER or WARNING safety signs are located near specific hazards. General precautions are listed on CAUTION safety signs. CAUTION also calls attention to safety messages in this manual.



DX,SIGNAL -19-03MAR93

TS187 -19-30SEP88

FOLLOW SAFETY INSTRUCTIONS

Carefully read all safety messages in this manual and on your machine safety signs. Keep safety signs in good condition. Replace missing or damaged safety signs. Be sure new equipment components and repair parts include the current safety signs. Replacement safety signs are available from your John Deere dealer.

Learn how to operate the machine and how to use controls properly. Do not let anyone operate without instruction.

Keep your machine in proper working condition. Unauthorized modifications to the machine may impair the function and/or safety and affect machine life.

If you do not understand any part of this manual and need assistance, contact your John Deere dealer.

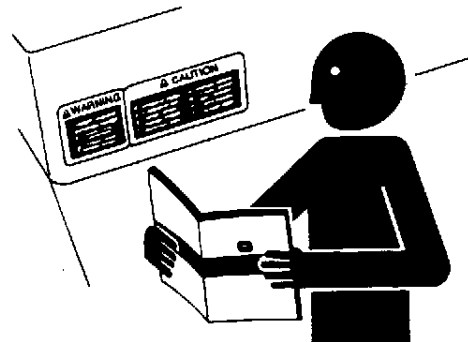

DX,READ -19-03MAR93

TS201 -UN-23AUG88



DRIVING THE COMBINE

Operate combine only when all guards are fitted and in their correct position.

Before driving away, check immediate vicinity of machine for bystanders. Use the horn as a warning immediately before driving away.

Attach headers to combine with extreme care.

H01,9000SA,A -19-11SEP92

KEEP RIDERS OFF MACHINE

Only allow the operator on the machine. Keep riders off.

Riders are subject to injury such as being thrown off the machine. Riders also obstruct the operator's view resulting in the machine being operated in an unsafe manner.

On machines equipped with a passenger seat, one rider is permitted.



H01,9000SA,B -19-20MAR90

TS253
-UN-23AUG88

BALLASTING FOR SAFE GROUND CONTACT

Operating, steering and braking performance of combine can be considerably affected by heavy front end attachments which alter the center of gravity of the combine.

To maintain the necessary ground contact, ballast the combine at the rear end as necessary.

Observe the maximum permissible axle loads and total weights.

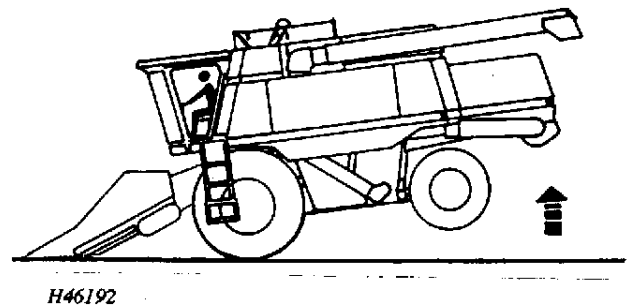

H46192

H01,9000SA,G -19-03JUN94

H46192
-UN-15APR94

<https://www.ebooklibonline.com>

Hello dear friend!

Thank you very much for reading.

Enter the link into your browser.

The full manual is available for immediate download.

<https://www.ebooklibonline.com>



AVOID ELECTRICAL POWER LINES

Put the grain tank unloading auger in transport position before driving on public roads.

Secure radio aerial in its transport position before driving on public roads, it may come into contact with low-hanging electrical cables. This would result in the operator suffering a severe electrical shock.

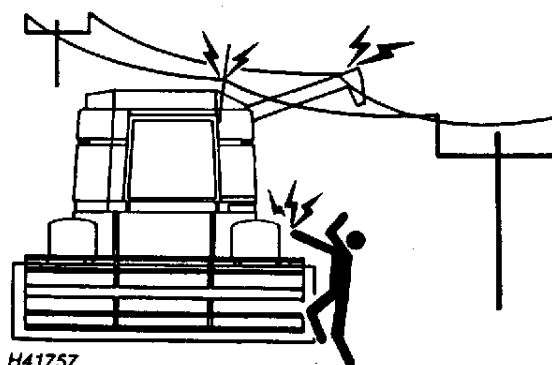

H41757

OM,9500SA,H -19-23JAN92

H41757 -UN-10MAR90

PARK THE COMBINE SAFELY

Lower headers or other equipment to the ground before leaving the combine. Turn off engine and remove keys.

Set the park brake.

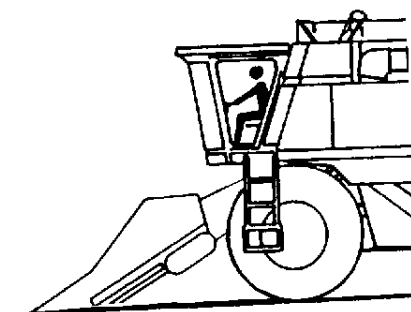

H46193

OM,9500SA,I -19-03JUN94

H46193 -UN-15APR94

OPERATE THE ENGINE OUTDOORS

Never operate the engine in a closed building.

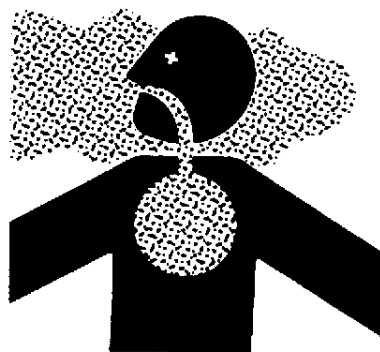

OM,9500SA,J -19-23JAN92

TS220 -UN-23AUG88

HANDLE FUEL SAFELY—AVOID FIRES

Handle fuel with care: it is highly flammable. Do not refuel the machine while smoking or when near open flame or sparks.

Always stop engine before refueling machine. Fill fuel tank outdoors.

Prevent fires by keeping machine clean of accumulated trash, grease, and debris. Always clean up spilled fuel.



DX,FIRE1 -19-03MAR93

TS202 -UN-23AUG88



PREPARE FOR EMERGENCIES

Be prepared if a fire starts.

Keep a first aid kit and fire extinguisher handy.

Keep emergency numbers for doctors, ambulance service, hospital, and fire department near your telephone.

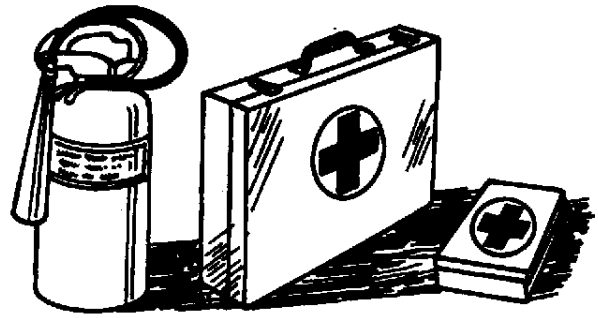

DX.FIRE2 -19-03MAR93

TS291 -UN-23AUG68

HANDLE STARTING FLUID SAFELY

Starting fluid is highly flammable.

Keep all sparks and flame away when using it. Keep starting fluid away from batteries and cables.

To prevent accidental discharge when storing the pressurized can, keep the cap on the container, and store in a cool, protected location.

Do not incinerate or puncture a starting fluid container.



DX.FIRE3 -19-16APR92

TS1356 -UN-18MAR92

WEAR PROTECTIVE CLOTHING

Wear close fitting clothing and safety equipment appropriate to the job.

Operating equipment safely requires the full attention of the operator. Do not wear radio or music headphones while operating machine.

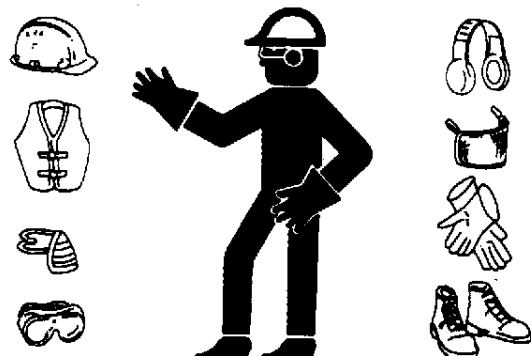

DX.WEAR2 -19-03MAR93

TS206 -UN-23AUG68



HANDLE CHEMICAL PRODUCTS SAFELY

Direct exposure to hazardous chemicals can cause serious injury. Potentially hazardous chemicals used with John Deere equipment include such items as lubricants, coolants, paints, and adhesives.

A Material Safety Data Sheet (MSDS) provides specific details on chemical products: physical and health hazards, safety procedures, and emergency response techniques.

Check the MSDS before you start any job using a hazardous chemical. That way you will know exactly what the risks are and how to do the job safely. Then follow procedures and recommended equipment.

(See your John Deere dealer for MSDS's on chemical products used with John Deere equipment.)



DX,MSDS,NA -19-03MAR93

TS1132 -UN-26NOV90

STAY CLEAR OF HEADER

Many moving parts such as the cutting platform auger, reel, gatherer chain and stalk rolls of the corn head, cannot be completely shielded due to their function. Stay clear of these moving elements during operation! Always disengage header drive, shut off the engine and remove key before servicing or unclogging header.



H42442

H42442 -UN-10JAN91

OM,CTSSA,C -19-12MAR93

KEEP HANDS AWAY FROM KNIVES

Never attempt to clear obstructions in front of or on header unless separator is disengaged, engine shut off and key removed.

Everyone must be clear of the combine before starting the engine



T5254 -UN-23AUG88

H01,9000SA,D -19-20MAR90



USE SAFETY LIGHTS AND DEVICES

Prevent collisions between other road users, slow moving tractors with attachments or towed equipment, and self-propelled machines on public roads. Frequently check for traffic from the rear, especially in turns, and use hand signals or turn signal lights.

Use headlights, flashing warning lights, and turn signals day and night. Follow local regulations for equipment lighting and marking. Keep lighting and marking visible and in good working order. Replace or repair lighting and marking that has been damaged or lost. An implement safety lighting kit is available from your John Deere dealer.

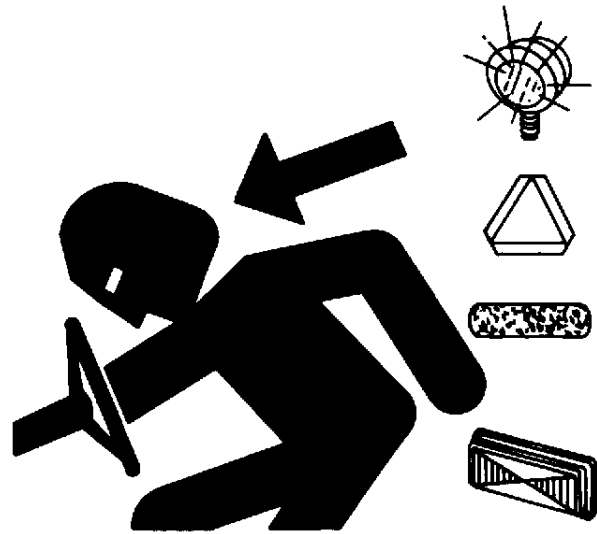

DX,FLASH -19-12SEP95

TS951 -UN-12APR90

USE SEAT BELTS

Use the seat belt whenever you operate the combine or ride as an observer.

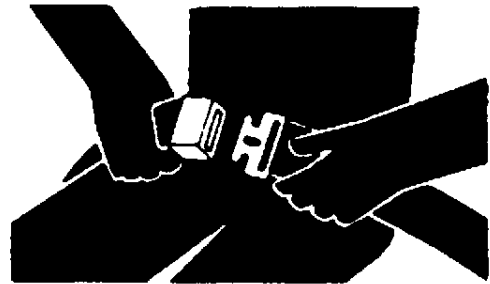

H47137

HX.9000SA,K -19-25OCT95

-UN-25OCT95
H47137

TRANSPORT COMBINE WITH HEADER SAFELY

Before driving combine on public roads, raise the header. It must not, however, obstruct operator's view of the road.

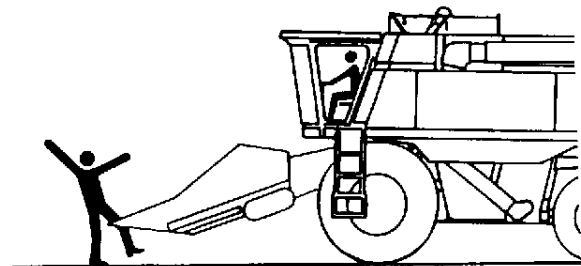

H46194

H01.9000SA,F -19-03JUN94

-UN-15APR94
H46194



AVOID CONTACT WITH MOVING PARTS

Keep hands, feet and clothing away from power driven parts. Never clean, lubricate or adjust machine when it is running.



H01,9000SA,E -19-15JUN90

TS256
-UN-23AUG88

TRANSPORT COMBINE SAFELY

Never drive the combine with the module in the service position.

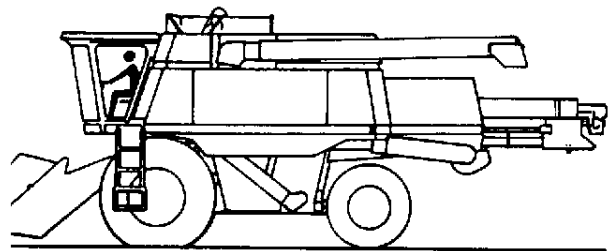

H44071

OM,CTSSA,A -19-23JAN92

H44071
-UN-09JAN92

PRACTICE SAFE MAINTENANCE

Understand service procedure before doing work. Keep area clean and dry.

Never lubricate, service, or adjust machine while it is moving. Keep hands, feet, and clothing from power-driven parts. Disengage all power and operate controls to relieve pressure. Lower equipment to the ground. Stop the engine. Remove the key. Allow machine to cool.

Securely support any machine elements that must be raised for service work.

Keep all parts in good condition and properly installed. Fix damage immediately. Replace worn or broken parts. Remove any buildup of grease, oil, or debris.

Disconnect battery ground cable (-) before making adjustments on electrical systems or welding on machine.



DX,SERV -19-03MAR93

TS218
-UN-23AUG88



REMOVE PAINT BEFORE WELDING OR HEATING

Avoid potentially toxic fumes and dust.

Hazardous fumes can be generated when paint is heated by welding, soldering, or using a torch.

Do all work outside or in a well ventilated area. Dispose of paint and solvent properly.

Remove paint before welding or heating:

- If you sand or grind paint, avoid breathing the dust. Wear an approved respirator.
- If you use solvent or paint stripper, remove stripper with soap and water before welding. Remove solvent or paint stripper containers and other flammable material from area. Allow fumes to disperse at least 15 minutes before welding or heating.

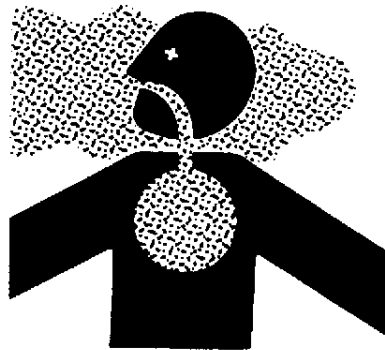

DX,PAINT -19-03MAR93

TS220 -UN-23AUG68

AVOID HEATING NEAR PRESSURIZED FLUID LINES

Flammable spray can be generated by heating near pressurized fluid lines, resulting in severe burns to yourself and bystanders. Do not heat by welding, soldering, or using a torch near pressurized fluid lines or other flammable materials. Pressurized lines can be accidentally cut when heat goes beyond the immediate flame area.



DX,TORCH -19-03MAR93

TS953 -UN-15MAY90



AVOID HIGH-PRESSURE FLUIDS

Escaping fluid under pressure can penetrate the skin causing serious injury.

Avoid the hazard by relieving pressure before disconnecting hydraulic or other lines. Tighten all connections before applying pressure.

Search for leaks with a piece of cardboard. Protect hands and body from high pressure fluids.

If an accident occurs, see a doctor immediately. Any fluid injected into the skin must be surgically removed within a few hours or gangrene may result. Doctors unfamiliar with this type of injury should reference a knowledgeable medical source. Such information is available from Deere & Company Medical Department in Moline, Illinois, U.S.A.

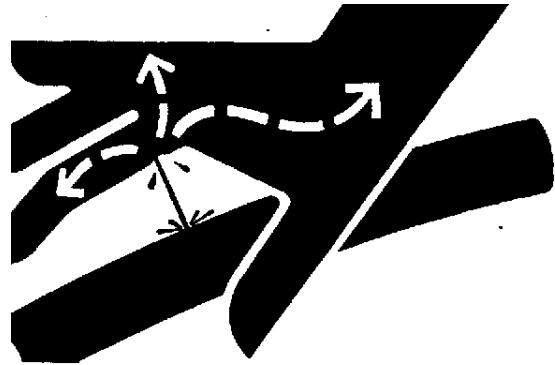

X9811 -UN-23AUG88

DX,FLUID -19-03MAR93

PROTECT AGAINST HIGH PRESSURE SPRAY

Spray from high pressure nozzles can penetrate the skin and cause serious injury. Keep spray from contacting hands or body.

If an accident occurs, see a doctor immediately. Any high pressure spray injected into the skin must be surgically removed within a few hours or gangrene may result. Doctors unfamiliar with this type of injury should reference a knowledgeable medical source. Such information is available from Deere & Company Medical Department in Moline, Illinois, U.S.A.

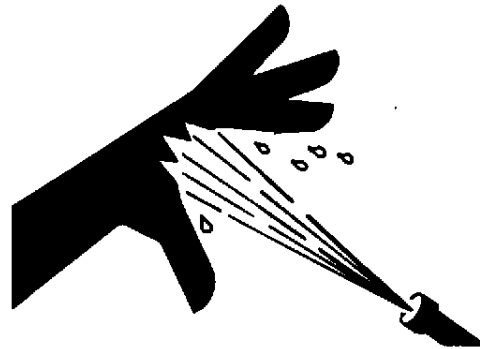

TS1343 -UN-18MAR92

DX,SPRAY -19-16APR92



DISPOSE OF WASTE PROPERLY

Improperly disposing of waste can threaten the environment and ecology. Potentially harmful waste used with John Deere equipment include such items as oil, fuel, coolant, brake fluid, filters, and batteries.

Use leakproof containers when draining fluids. Do not use food or beverage containers that may mislead someone into drinking from them.

Do not pour waste onto the ground, down a drain, or into any water source.

Air conditioning refrigerants escaping into the air can damage the Earth's atmosphere. Government regulations may require a certified air conditioning service center to recover and recycle used air conditioning refrigerants.

Inquire on the proper way to recycle or dispose of waste from your local environmental or recycling center, or from your John Deere dealer.

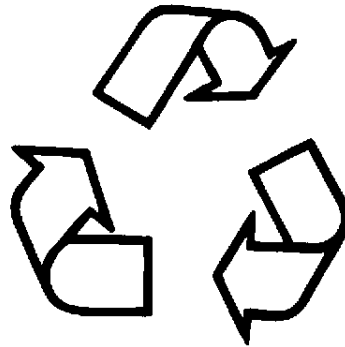

DX,DRAIN -19-03MAR93

TS1133 -UN-26NOV90

SERVICE COOLING SYSTEM SAFELY

Explosive release of fluids from pressurized cooling system can cause serious burns.

Shut off engine. Only remove filler cap when cool enough to touch with bare hands. Slowly loosen cap to first stop to relieve pressure before removing completely.



DX,RCAP -19-04JUN90

TS281 -UN-23AUG88

Safety Decal Location

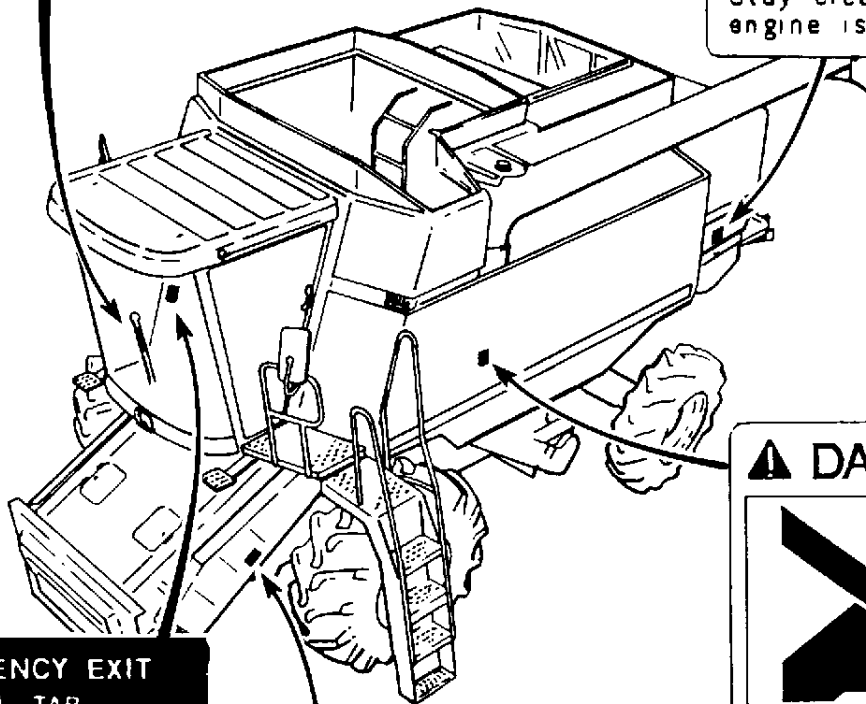
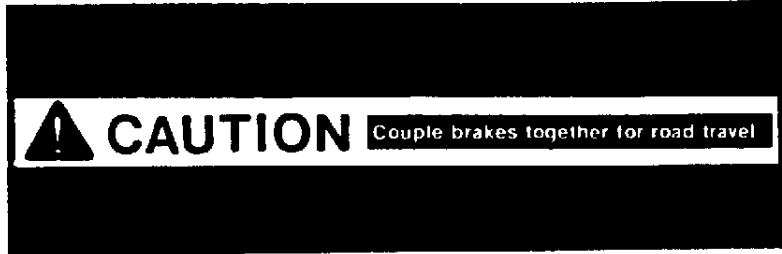

EMERGENCY EXIT
PULL TAB
REMOVE ROPE
PUSH WINDOW

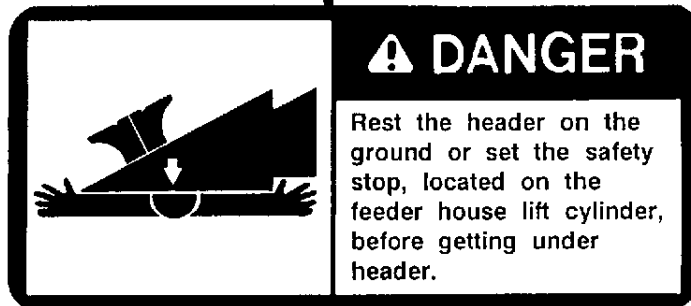
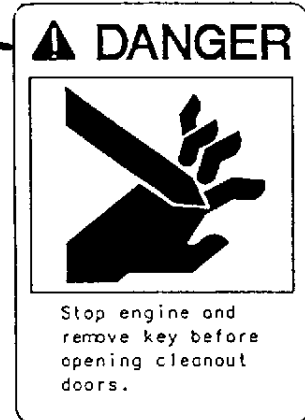

H48051

-19-12AUG96

H48051

OM,9500SS,A -19-18NOV96

Safety Decal Location

CAUTION

Avoid bodily injury from rotating auger and components:

Shut engine off and remove key before opening or closing auger.

Keep hands from pinch points when closing auger.

DANGER



DO NOT enter grain tank when engine is running.

DANGER

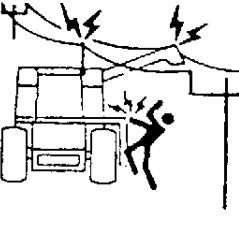

To avoid injury or death, **DO NOT** contact electric lines.

CAUTION

Use the seat belt whenever you operate the combine or ride as an observer.

CAUTION

1. Couple brakes together for road transport.
2. Engage park brake prior to leaving cab.

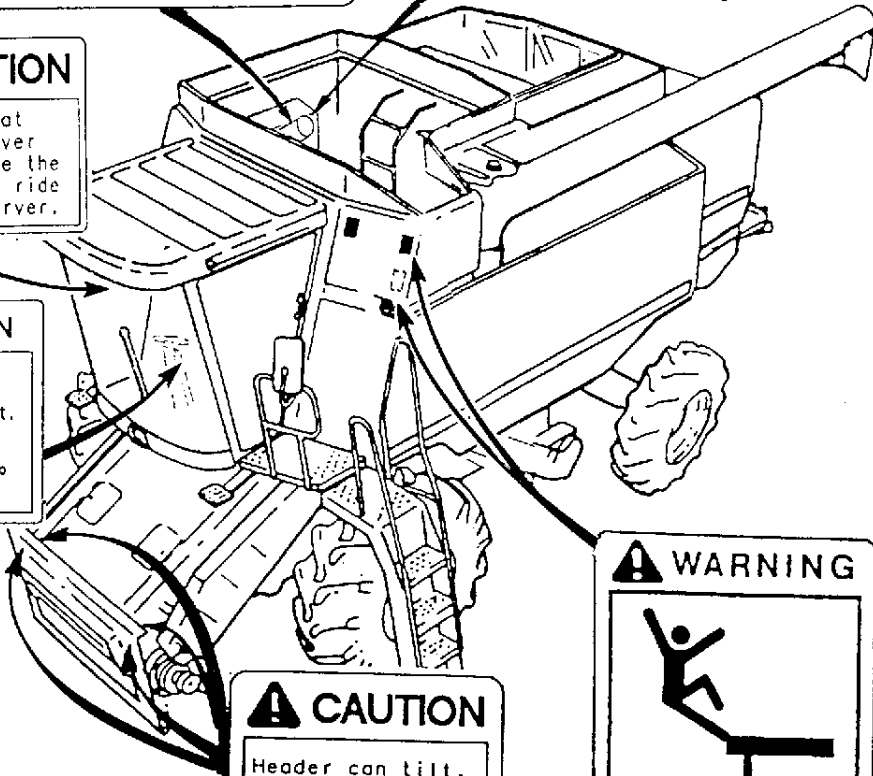

CAUTION

Header can tilt. Avoid crushing injuries. Stay clear when engine is running.

WARNING



Do not enter grain tank in this area.

(COMBINES WITH CONTOUR MASTER ONLY)

H48128

-19-24OCT96

H48128

OM,9500SS,B -19-18NOV96

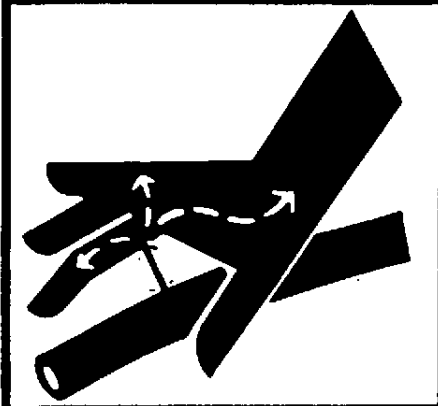

⚠ WARNING

Avoid bodily injuries from hydraulic oil and gas under pressure.

Before removing, disassembling or changing accumulator:

1. With feederhouse or header on the ground or in a supported position, open hand valve.
2. Start engine and hold header height control to lower position for 5 seconds to relieve system hydraulic pressure.
3. Stop engine.

Use only DRY NITROGEN for recharging accumulator. See your John Deere dealer

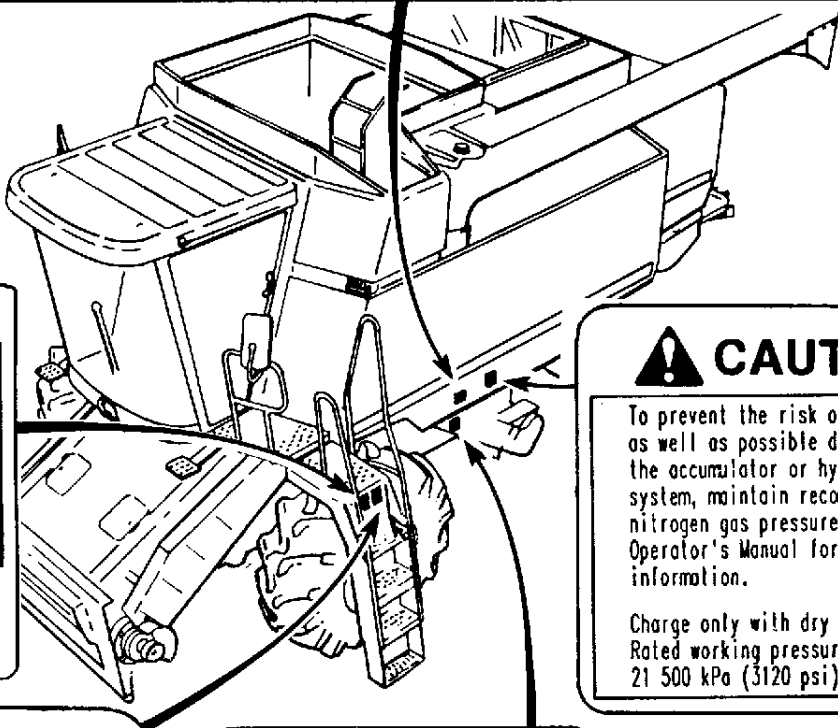

⚠ WARNING



Do not ride ladder while combine is moving.

⚠ CAUTION

To prevent the risk of injury, as well as possible damage to the accumulator or hydraulic system, maintain recommended nitrogen gas pressure. See Operator's Manual for additional information.

Charge only with dry nitrogen. Rated working pressure is 21 500 kPa (3120 psi)

⚠ CAUTION

1. Keep all shields in place.
2. Disengage and shut off all engine and/or motor power before servicing or unclogging machine.
3. Keep hands, feet, and clothing away from power-driven parts.

⚠ WARNING

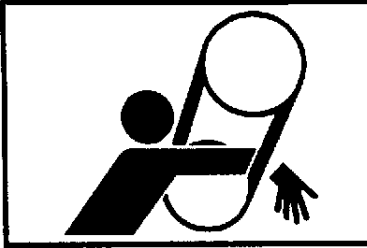

Never raise shield with the engine running. Stop engine and remove key.

H48053

-19-12AUG96
H48053

OM,9500SS.C -19-18NOV96

Safety Decal Location

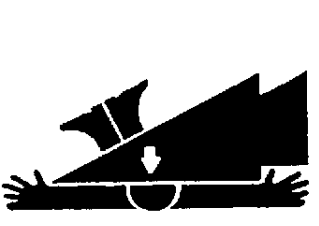

⚠ DANGER

Rest the header on the ground or set the safety stop, located on the feeder house lift cylinder, before getting under header.

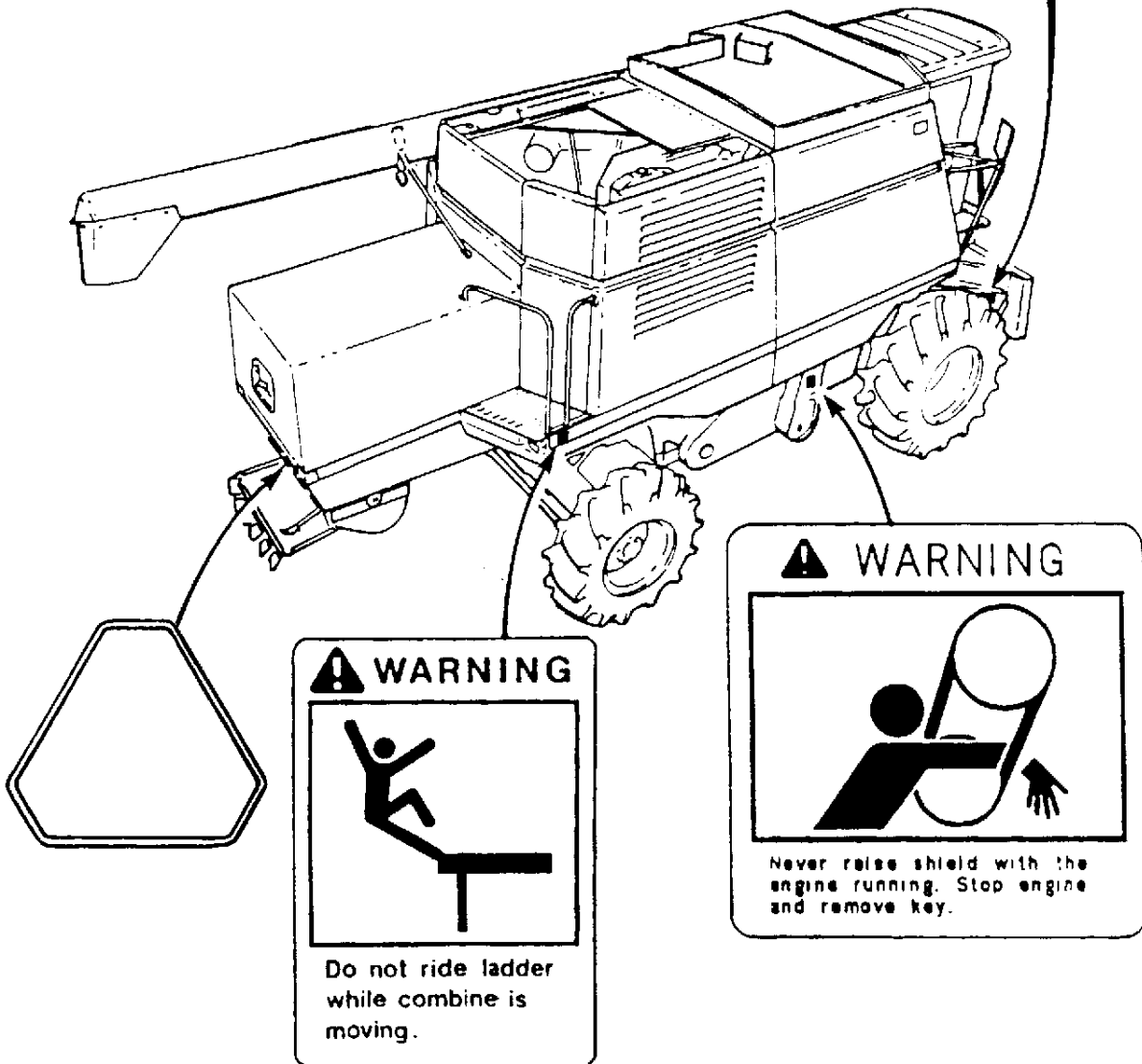

H48129

-19-24OCT96

H48129

OM,CTSSS,A -19-18NOV96

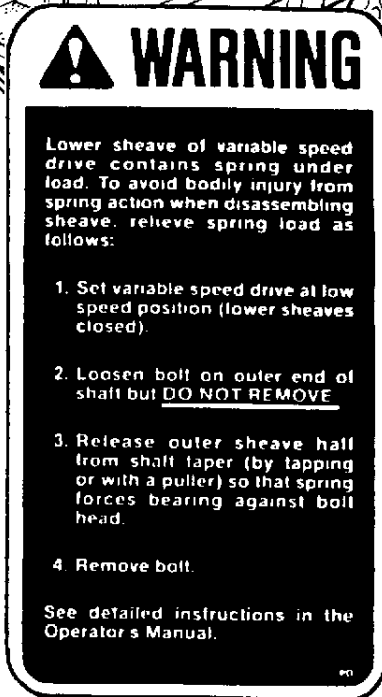
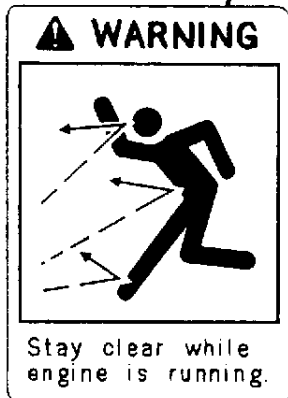
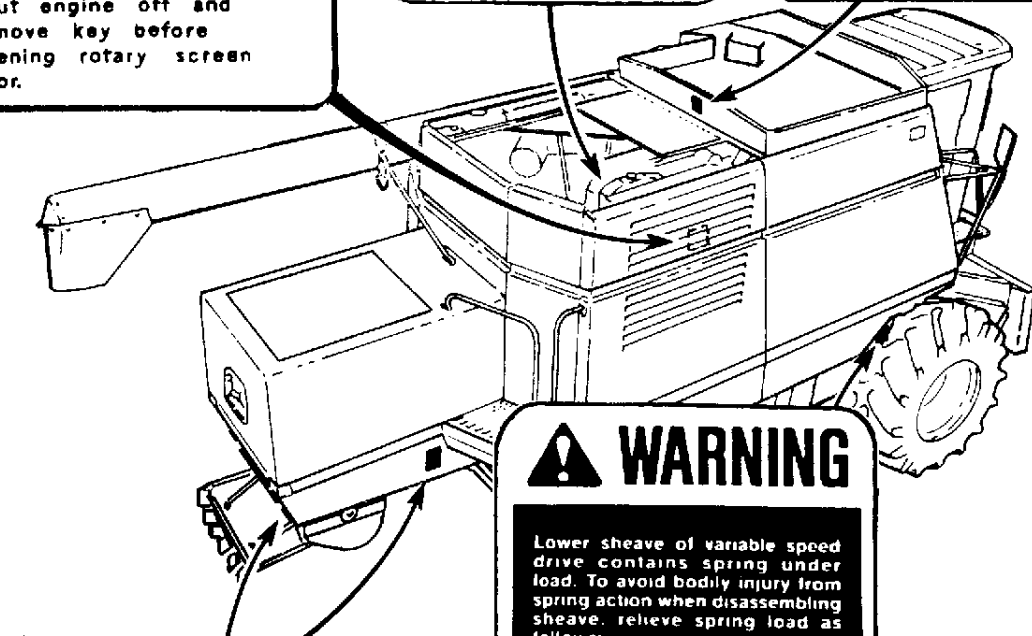

H48130

-19-24OCT96

H48130

OM,CTSSS,B -19-18NOV96

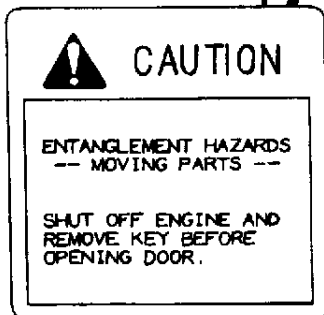
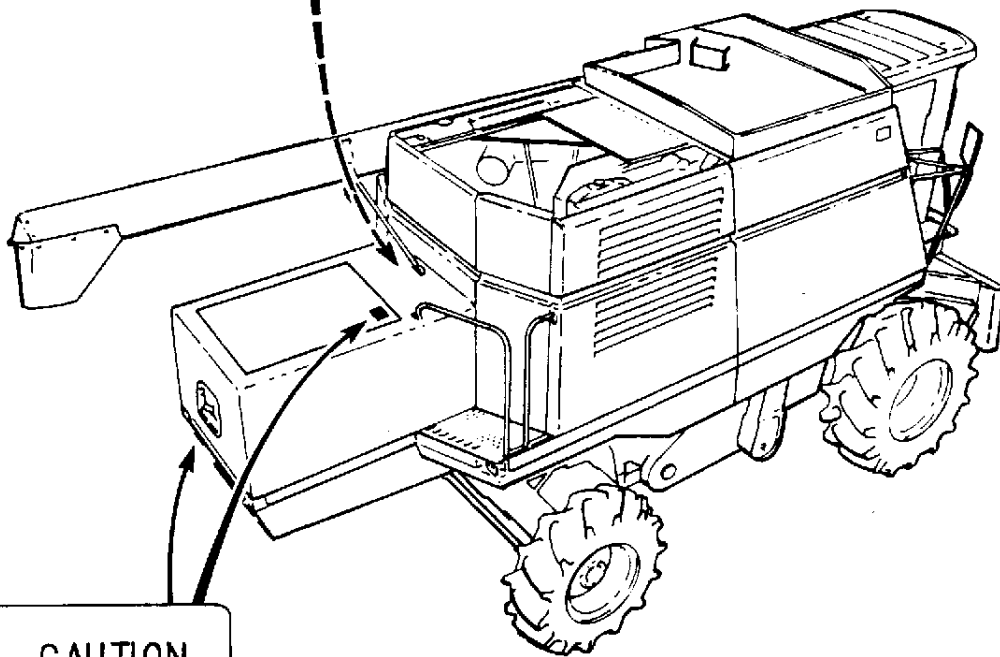
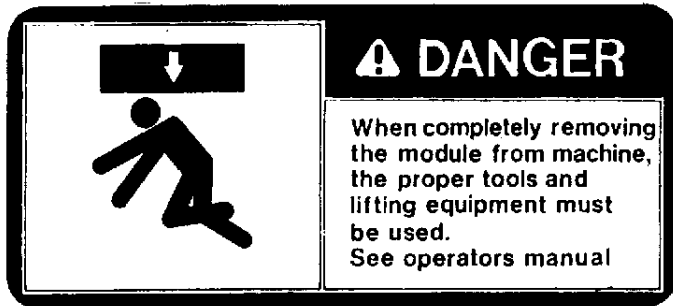

R44077

-JUN-14/JAN92

H44077

CTS,SS,A -19-23JAN92

Operators Station

INSTRUMENTS AND CONTROLS IDENTIFICATION

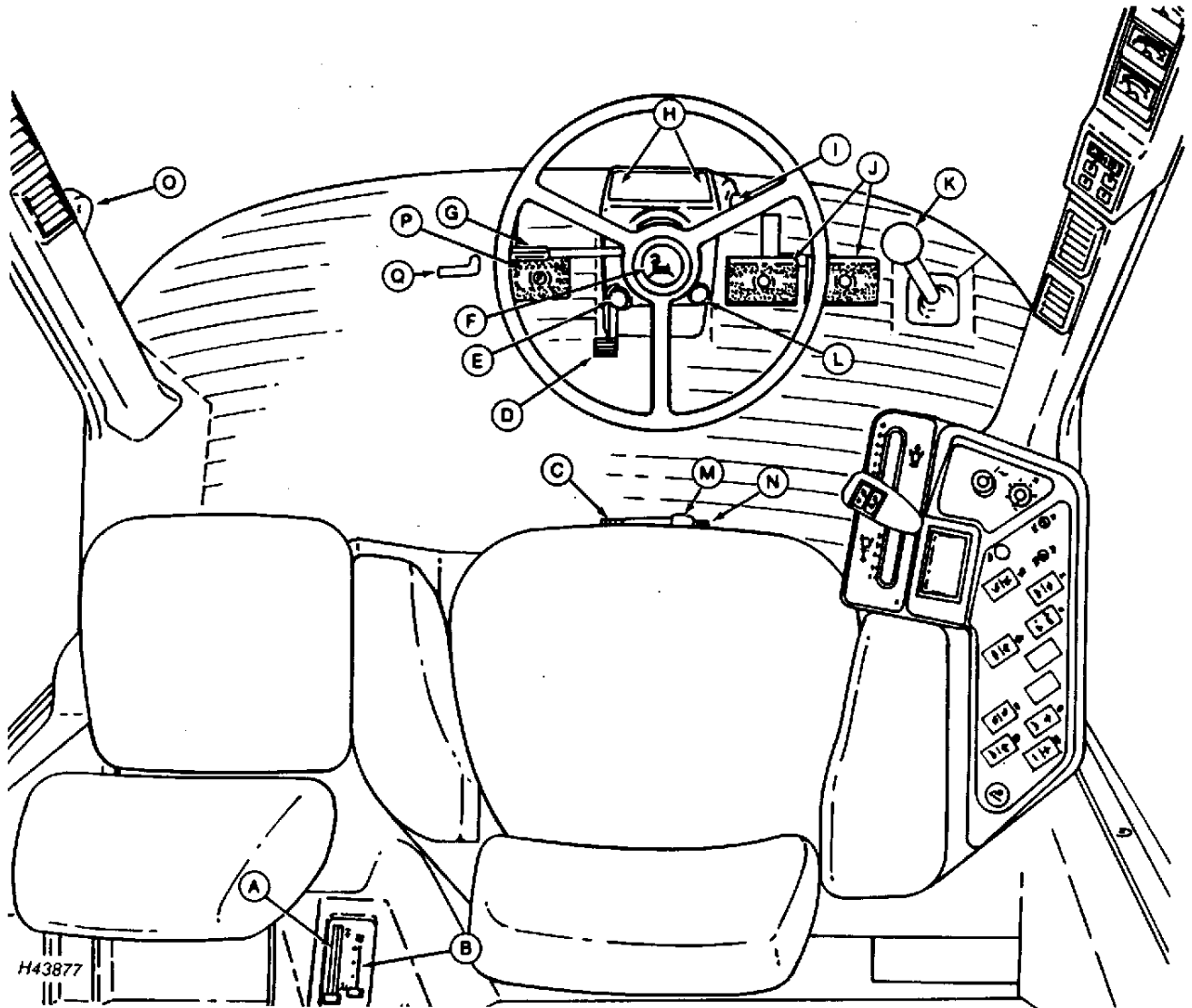

A—Air Conditioning/Heater,
Temperature Control
B—Cab Fan Speed Control
C—Reverser Control
D—Steering Column Tilt
Pedal

E—Ether Aid Button
F—Steering Wheel Lock
Knob
G—Turn Signal Lever
H—Turn Signal Indicators
I—Start Switch

J—Brake Pedals
K—Gearshift Lever
L—Horn Button
M—Seat Position Lever
N—Seat Height Lever

O—Accumulator Gauge
(Optional)
P—Manual Park Brake Pedal
Q—Park Brake Disengage
Pedal

OM.9500S.A -19-26MAR97



Suggest:

For more complete manuals. Please go to the home page.

<https://www.ebooklibonline.com>

If the above button click is invalid. Please download this document first, and then click the above link to download the complete manual.

Thank you so much for reading

SWITCH AND KNOB COLORS

Before operating this combine for the first time, become familiar with the switches and controls. These controls are color "coded" to help you quickly locate them when operating the combine.

- Red - Engine Stop
- Orange - ground drive and engine speed.
- Yellow - drive engagement.
- Black - operating adjustments and controls.



H42330 -UN-11SEP90

OM,95000S,B -19-26MAR97

ARMREST CONTROL PANEL

- A—DIAL-A-MATIC™ (Optional)
- B—DIAL-A-SPEED™ Control (Optional)
- C—Header Engage
- D—Unloading Auger Engage
- E—Separator Engage
- F—Manual Reel Speed
- G—Reel Fore-and-Aft (Optional)
- H—CONTOUR MASTER™ On/Off Switch (Optional)
- I—Cylinder Speed
- J—Concave Spacing
- K—Cigarette Lighter
- L—Cleaning Fan Speed
- M—Four-Wheel Drive (Optional)
- N—Engine Speed
- O—Unloading Auger Swing
- P—Ash Tray
- Q—Hydrostatic Drive Control Lever
- R—Reel Lift/Feederhouse Speed
- S—Header Lift
- T—CONTOUR MASTER™ Manual Tilt Switch (Optional)

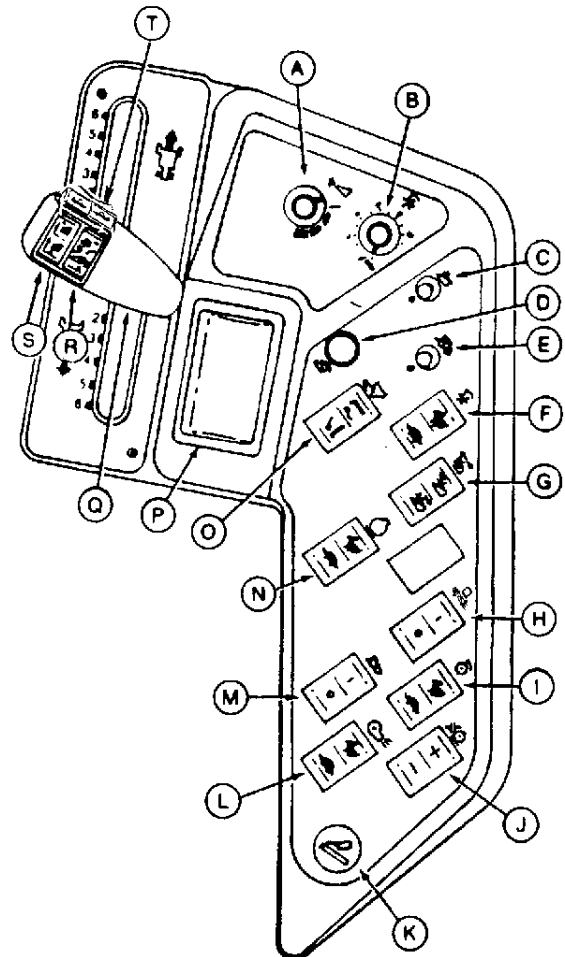

H46248

H46248 -UN-13DEC94

OM,95000S,C -19-21DEC94

DIAL-A-MATIC (OPTIONAL)

The knob controls header automatic height with three "ON" positions. See your header Operator's Manual for details.

The DIAL-A-MATIC automatically shuts off when the header is raised by using the rocker switch in the hydro handle. The system will turn itself back on when the header is lowered.

If the reel lift, variable speed feeder house or variable speed cylinder drive are operated when the DIAL-A-MATIC is functioning, these systems may not work properly.

IMPORTANT: Be certain knob is in the "OFF" position when the platform cutterbar is locked out.

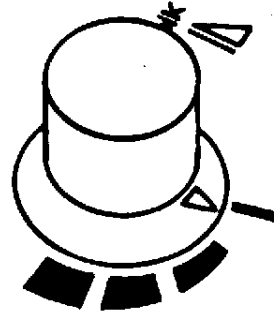

H43710

-UN-06AUG91
H43710

OM,9500OS,AD -19-23JAN92

DIAL-A-SPEED (OPTIONAL)

The DIAL-A-SPEED knob controls the ratio of the reel speed or the belt pickup to ground speed.

To operate, start the engine and drive forward with the separator and header engaged.

Turn the DIAL-A-SPEED knob to position 3.

Watch the speed of the reel or belt pickup and adjust the DIAL-A-SPEED knob until you get the desired ratio to ground speed.

The reel or belt pickup will now speed up or slow down in relation to the ground speed.

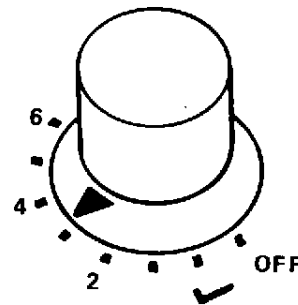

H41587

-UN-14FEB90
H41587

OM,CTSOS,A -19-12MAR93

<https://www.ebooklibonline.com>

Hello dear friend!

Thank you very much for reading.

Enter the link into your browser.

The full manual is available for immediate download.

<https://www.ebooklibonline.com>