

**2054, 2056, 2058,
2064 and 2066
Combines**
(From Serial No. 064253)

**John Deere Werke Zweibrücken
OMZ92483 Issue D6**

European Edition
Printed in Germany
ENGLISCH

Contents

	Page		Page
Identification View	00-1	Sensitivity of sensors	20-47
Safety	05-1	Operational check	20-48
Safety Decals	10-1	Straw warning device	20-49
Controls and Instruments		Lighting System and Signals	
Survey	15-1	Parking light and low-beam	25-1
Switch console	15-2	Full beam	25-1
Multi-function lever	15-7	Turn signals	25-2
Roof switch console	15-9	Work lights	25-4
Roof console	15-10	Beacon lights	25-7
Harvest performance monitor	15-11	Hazard warning lights	25-8
Steering column	15-12	Indicator light bulb test	25-8
Switch console — Functions	15-13	Operator's Cab	
Right armrest — Functions	15-35	Door	30-3
Multi-function lever — Functions	15-37	Operator's seat	30-3
Roof console — Functions	15-40	Lumbar support	30-4
Steering column — Functions	15-42	Left armrest	30-4
Warning Devices and Monitors		Right armrest	30-4
Indicator lights I	20-1	Ashtray	30-5
Indicator lights II	20-5	Passenger seat	30-6
Header height gauge	20-11	Storage compartment for operator's	
Distributor plate gauge	20-11	manuals	30-6
Fuel gauge	20-11	Cooling compartment	30-7
Coolant temperature gauge	20-11	Steering column	30-7
Infotrak monitor	20-12	Foot brakes	30-8
Cylinder speed alarm	20-17	Parking brake	30-8
SERVICE information	20-18	Releasing parking brake	30-9
Automatic adjustments	20-19	Sun visor	30-9
Combine data center	20-20	Outside mirrors	30-10
Area counter	20-23	Switching on heater	30-10
Operational diagrams	20-27	Adjustable air louvers	30-11
Low shaft speed monitor system	20-41	Interior lighting	30-12
Harvest performance monitor	20-43	Digital clock	30-12
Preliminary adjustments	20-44	Radio und Citizens' Band	30-13
Switching on harvest performance		Rear window of cab	30-13
monitor	20-44	Pre-Starting Checks	
Operational adjustment	20-45	Daily checks	35-1

Continued on next page

All information, illustrations and specifications in this manual are based on the latest information available at the time of publication. The right is reserved to make changes at any time without notice.

OMZ92483 D6-19-01MAY96

COPYRIGHTL 1996
DEERE & COMPANY
European Office Mannheim
All rights reserved
A John Deere ILLUSTRATION® Manual
Previous Editions
Copyright 1995, 1992 Deere & Company

Contents

	Page		Page
Engine oil level	35-1	Adjusting cylinder and concave	55-3
Hydraulic oil level	35-1	Normal crops	55-3
Coolant level	35-2	Coarse crops	55-4
Fuel level	35-2	Separating process	55-4
Tires	35-2	Grain cleaning process	55-5
Fuel system	35-3	Grain recovery	55-5
Lubricating the combine	35-3	Evaluating threshing action	55-6
Checks in operator's cab	35-3	Checking straw at rear of combine	55-6
 		Grain tank sample	55-6
Operating the Engine		Checking tailings	55-7
Engine break-in	40-1	Identifying threshing problems	55-7
Starting the engine	40-1	Overthreshing	55-8
Engine oil pressure indicator light	40-4	Undertreshing	55-8
Warming up the engine	40-4	Adjusting fan speed	55-9
Idling the engine	40-4	Adjusting the chaffer	55-10
Cold-weather starting aid	40-5	Slope Master system	55-11
Coolant preheater	40-7	Adjusting the sieve	55-12
Booster battery	40-8	Acceptable grain losses	55-12
Stopping the engine	40-9	The meaning of grain losses	55-12
 		Determining grain losses	55-13
Driving and Transporting Harvester		Causes of grain losses	55-15
Driving the harvester	45-1	Cutting platform losses	55-15
Releasing parking brake	45-1	Threshing unit losses	55-15
Operating the foot brakes	45-2	Straw walker losses	55-16
Engaging a gear	45-2	Sieve losses	55-16
Road safety switch	45-3	General prevention of grain losses	55-17
Adjusting engine speed	45-3	Threshing adjustments	55-18
Raising header	45-3	Combine settings and automatic adjustments	55-19
Forward and reverse travel	45-4	Additional combine settings	55-20
Ground speed	45-5	Preparations before changing crop	55-21
Hydrostatic system	45-6	Preparations for harvesting grain crops	55-22
Transport information	45-6	Preparations for harvesting peas	55-22
Four-wheel drive	45-8	Preparations for harvesting corn	55-22
Towing the harvester	45-9	Harvesting corn/cob mix (CCM)	55-23
 		Preparations for harvesting oil seed crops	55-23
Wheels, Axles and Additional Weights		Operating the combine harvester	55-23
Tire maintenance	50-1	Header float control	55-26
Wheel bolts and nuts	50-1	Header function resume	55-26
Mounting tires	50-3	 	
Changing tires	50-4	Feeder House	
Driven wheels	50-4	Electrical and hydraulic connections	60-1
Steered wheels	50-8	Securing header lift cylinders	60-2
Tire pressures	50-9	Service flaps	60-2
 		Chain tension	60-3
Preparations and Field Operation		Adjusting height of feeder drum	60-4
Choice of harvesting time	55-1	Adjusting the area counter switch	60-4
Avoiding grain losses	55-1	Slip clutch on upper feeder shaft	60-5
Cutting platform	55-2	Stripper on upper feeder shaft	60-6
Feeder house	55-2	Lower unit, feeder house variator	60-6
Separator	55-2		

Continued on next page

<https://www.ebooklibonline.com>

Hello dear friend!

Thank you very much for reading.

Enter the link into your browser.

The full manual is available for immediate download.

<https://www.ebooklibonline.com>

Page	Page		
Reverser shifter fork and cable	60-7	Mechanical adjustment, centrally	70-6
Separator and Cleaning Unit		Separate adjustment of deflectors	70-6
Service flaps	65-1	Adjusting counter-knives	70-6
Opening stone trap bottom plate	65-2	Chopping corn and sunflowers	70-7
Grain pan inserts	65-2	Removing counter-knives	70-7
Cylinder rasp bars	65-3	Splitting and chopping	70-8
Cylinder reduction gear	65-4	Replacing rotating knives	70-9
Turning the cylinder	65-5	Grain Tank Loading and Unloading	
Cylinder filler plates	65-6	Service openings	75-1
Grain concave	65-6	Grain tank cover	75-3
Corn concave	65-7	Opening the grain tank cover	75-4
Universal concave	65-7	Checking and tensioning feeder chains	75-5
Booster bar	65-7	Unloading drive overload protection	75-6
Special rasp bar	65-8	Cover for unloading auger	75-6
De-awning plates	65-8	Sensor for grain tank filling gauge	75-7
Concave settings	65-9	Spill guard on discharge tube outlet	75-7
Changing the concave	65-9	Fuel, Lubricants, Coolant and Capacities	
Concave basic setting	65-9	Engine oil	80-3
Adjusting the concave	65-12	Coolant	80-4
Second cylinder	65-13	Transmission oil	80-5
Second concave	65-13	Changing transmission oil	80-8
Finger rakes	65-14	Hydraulic oil	80-9
Curtain	65-14	Brake fluid	80-10
Cross-shaker tines	65-15	Grease	80-11
Straw rakes	65-16	Alternative lubricants	80-11
Straw walkers	65-17	Lubricant storage	80-12
Fan and windboard	65-19	Lubrication Chart, Periodic Service	
Metal sheet to separate chaff from straw	65-20	Lubrication charts	85-1
Sieve variants	65-21	Break-in period	85-10
Chaffer and sieve adjustment	65-23	Service intervals	85-10
Chaffer extension	65-24	After the first 100 hours	85-11
Chaffer extension inserts	65-25	Every 250 hours	85-11
Removing chaffer extension	65-26	Every 500 hours	85-12
Removing chaffer	65-26	Every 1000 hours	85-12
Removing sieve	65-27	Every 1500 hours	85-12
Side-curtain	65-28	As required	85-12
Chaff Spreader and Straw Chopper		Once every year	85-13
Chaff spreader	70-1	Every 2 years	85-13
Operation	70-1	Service — Engine	
Guard rail	70-1	Access to engine	90-1
Folding down the chaff spreader	70-2	Engine compartment	90-1
Hydraulic connections	70-2	Adjusting engine valve tappets	90-2
Vanes on chaff spreader rotors	70-3	Checking engine crankcase oil level	90-2
Straw chopper	70-3	Oil and filter change — 6.8-L engine	90-3
Switching chopper on and off	70-4	Oil and filter change — 7.6-L engine	90-4
Adjusting straw distributor box	70-4	Service — Fuel system	90-5
Driving on public roads	70-5		
Adjusting straw deflectors	70-5		
Electrical adjustment, centrally	70-5		

Continued on next page

Contents

	Page		Page
Fuel system — 6.8-L engine	90-6	Relay and diode board	100-10
Fuel system — 7.6-L engine	90-7	Solenoid valves — Basic machine	100-13
Fuel tank filler neck	90-8	Solenoid valves — Hillmaster	100-14
Fuel tank water trap	90-8	Error codes, infotrak monitor	100-15
Water trap in fuel system	90-9	Microswitches and diodes	100-17
Fuel transfer pump — 6.8-L engine	90-10	Error codes, reel speed control	100-18
Fuel filter — 6.8-L engine	90-11		
Fuel filter — 7.6-L engine	90-12	Service — Hydraulic System	
Injection nozzles — 7.6-L engine	90-13	Pressure relief valve	105-1
Bleeding the fuel system	90-13	System description	105-2
Access to cooling elements	90-15	Hydraulic components	105-3
Layout of cooling elements	90-16	Hydraulic components, Hillmaster	105-5
Engine coolant	90-17	Hydraulic components, chaff spreader	105-6
Flushing the cooling system	90-18	Actuating electro-magnetic valves	105-7
Changing the thermostats	90-21	Accumulators	105-10
Drive belts — 6.8-L engine	90-22	Draining hydraulic oil	105-11
Drive belts — 7.6-L engine	90-22	Replacing hydraulic oil filter	105-12
Air intake system	90-23	Refilling hydraulic oil	105-13
Air cleaner (primary) element	90-25	Temperature/pressure sending units	105-14
Turbocharger	90-29		
Crankshaft vibration damper	90-30	Service — Ground Speed Drive	
		Brake system	110-1
Service — Drives and Shields		Brake fluid reservoir	110-2
Safety shields	95-1	Adjusting the foot brakes	110-2
Adjusting belts	95-2	Parking brake	110-2
Main countershaft	95-3	Hydrostatic drive components	110-3
Unloading drive	95-4	Oil cooler	110-4
Cylinder drive intermediate countershaft	95-5	Oil and filter change	110-5
Adjusting the fan variator	95-6	Transmission	110-6
Clean grain elevator, grain tank loading	95-7	Final drives	110-7
Countershaft for slip clutch and grain elevator	95-7	Rear wheel toe-in	110-8
Slip clutch for straw walker drive	95-8	Rear wheel tread	110-9
Slip clutch for tailings elevator	95-8	Steering components	110-11
Belt tensioners	95-9		
Drive chains	95-10	Service — Air Conditioning and Heating	
Tailings elevator drive chain	95-10	Air conditioning components	115-1
Tailings elevator drive chain	95-10	Heater components	115-2
Unloading drive countershaft	95-11	Air intake and distribution	115-3
Drive chain for grain tank unloading	95-11	Compressor	115-4
V-belts	95-11	Refrigerant level	115-5
		Low-pressure switch	115-5
Service — Electrical System		High-pressure switch	115-6
Specifications	100-1	Cleaning the condenser	115-6
Batteries	100-1	Cab air filters	115-6
Alternators	100-4	Air intake opening	115-8
Starting motor	100-5	Condensation water drain hose	115-9
Electronic boards	100-6		
Fuses on fuse boards	100-7	Storage	
Relays on fuse boards	100-9	After the season	120-1
		Removing combine from storage	120-4

Continued on next page

Contents

Page

Specifications

Operating speeds 125-1
Dimensions (2054, 2056) 125-13
Dimensions (2058, 2064) 125-15
Dimensions (2066) 125-17

Serial Numbers

Type plates 130-1

Index

Contents

Identification View



-JUN-22MAY95
ZX004251

ZX,OMXZC0001970-19-13NOV92

Safety

RECOGNIZE SAFETY INFORMATION

This is the safety-alert symbol. When you see this symbol on your machine or in this manual, be alert to the potential for personal injury.

Follow recommended precautions and safe operating practices.



DX,ALERT -19-03MAR93

T81389 -UN-07DEC68

FOLLOW SAFETY INSTRUCTIONS

Carefully read all safety messages in this manual and on your machine safety signs. Keep safety signs in good condition. Replace missing or damaged safety signs. Be sure new equipment components and repair parts include the current safety signs. Replacement safety signs are available from your John Deere dealer.

Learn how to operate the machine and how to use controls properly. Do not let anyone operate without instruction.

Keep your machine in proper working condition. Unauthorized modifications to the machine may impair the function and/or safety and affect machine life.

If you do not understand any part of this manual and need assistance, contact your John Deere dealer.

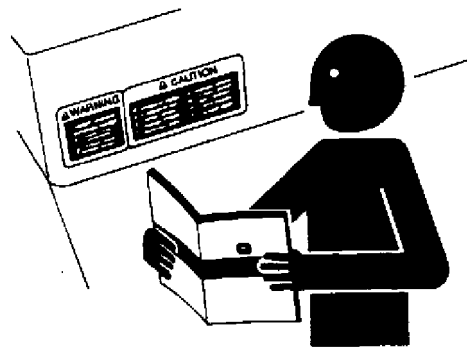

DX,READ -19-03MAR93

T5201 -UN-23AUG88

UNDERSTAND SIGNAL WORDS

A signal word—DANGER, WARNING, or CAUTION—is used with the safety-alert symbol. DANGER identifies the most serious hazards.

DANGER or WARNING safety signs are located near specific hazards. General precautions are listed on CAUTION safety signs. CAUTION also calls attention to safety messages in this manual.



DX,SIGNAL -19-03MAR93

TS187 -19-30SEP88



OBSERVE ROAD TRAFFIC REGULATIONS

Always observe local road traffic regulations when using public roads.



H28930 -UN-30JUN89

FX,ROAD -19-01MAY91



CAUTION: Avoid possible injury or death from machinery runaway.

Do not start engine by shorting across starter terminals. Machine will start in gear if normal circuitry is bypassed.

NEVER start engine while standing on ground. Start engine only from operator's seat, with transmission in neutral or park.

DX,BYPAS -19-26JAN90



USE SAFETY LIGHTS AND DEVICES

Slow moving tractors, self-propelled equipment and towed implements or attachments can create a hazard when driving on public roads. They are difficult to see, especially at night. Avoid personal injury or death resulting from collision with a vehicle.

If legally permitted, use flashing warning lights or rotary beacons whenever driving on public roads. To increase visibility, use the lights and devices provided with your machine. For some equipment, install additional flashing warning lights.

Keep safety items in good condition. Replace missing or damaged items. An implement safety lighting kit is available from your John Deere dealer.

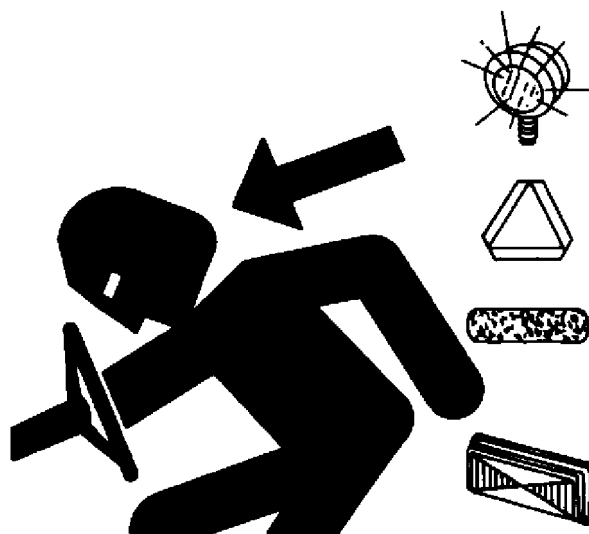

ZX,FLASH -19-01OCT91

TS951 -UN-12APR90

PREPARE FOR EMERGENCIES

Be prepared if a fire starts.

Keep a first aid kit and fire extinguisher handy.

Keep emergency numbers for doctors, ambulance service, hospital, and fire department near your telephone.

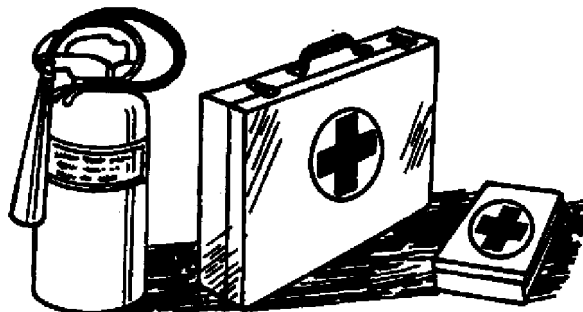

DX,FIRE2 -19-03MAR93

TS291 -UN-23AUG88



WEAR PROTECTIVE CLOTHING

Wear close fitting clothing and safety equipment appropriate to the job.

Prolonged exposure to loud noise can cause impairment or loss of hearing.

Wear a suitable hearing protective device such as earmuffs or earplugs to protect against objectionable or uncomfortable loud noises.

Operating equipment safely requires the full attention of the operator. Do not wear radio or music headphones while operating machine.

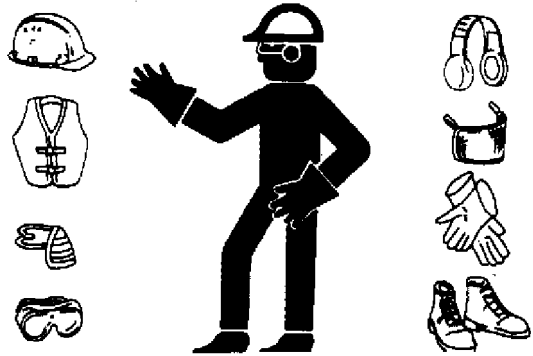

DX,WEAR -19-10SEP90

TS206 -UN-23AUG88

HANDLE FUEL SAFELY—AVOID FIRES

Handle fuel with care: it is highly flammable. Do not refuel the machine while smoking or when near open flame or sparks.

Always stop engine before refueling machine. Fill fuel tank outdoors.

Prevent fires by keeping machine clean of accumulated trash, grease, and debris. Always clean up spilled fuel.



DX,FIRE1 -19-03MAR93

TS202 -UN-23AUG88

STORE ATTACHMENTS SAFELY

Stored attachments such as dual wheels, cage wheels, and loaders can fall and cause serious injury or death.

Securely store attachments and implements to prevent falling. Keep playing children and bystanders away from storage area.

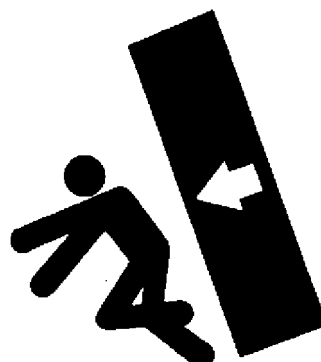

DX,STORE -19-03MAR93

TS219 -UN-23AUG88



FIRE EXTINGUISHER

A 6 kg (13 lb) general purpose fire extinguisher meeting local legal requirements has to be installed on the left-hand side of the operator's platform.

Maintain fire extinguisher to keep it in operational condition.

Keep the engine clean and free of dust, chaff and straw to prevent the possibility of a fire.

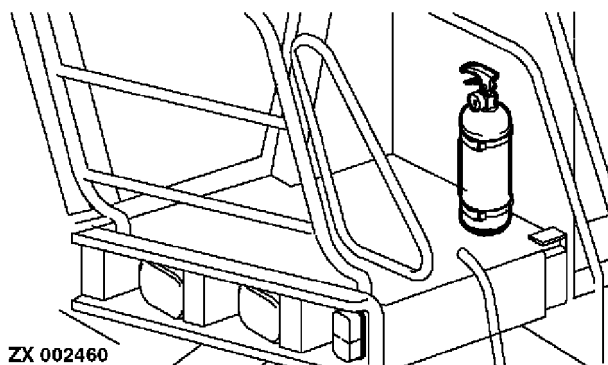

ZX 002460

ZX, FIREXZCO -19-27MAY94

ZX002460 -UN-16JUN95

CHECK MACHINE SAFETY

Always check the road and general operating safety of the machine before using.

FX, READY -19-28FEB91

MOUNT AND DISMOUNT SAFELY

Use handrail when mounting or dismounting the combine.

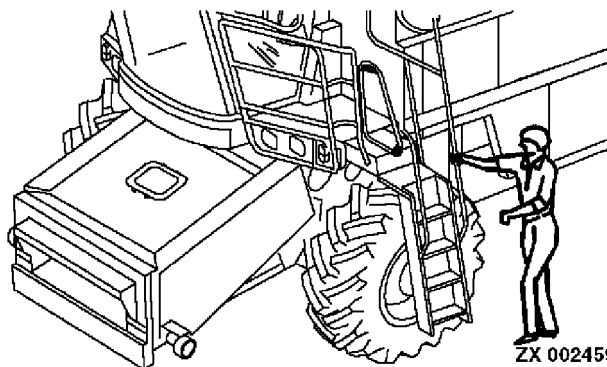

ZX 002459

ZX, HANDLEXZCO -19-27JAN92

ZX002459 -UN-16JUN95

RIDERS

Only allow the operator and one rider on the machine.

Other riders are subject to injury such as being thrown off the machine and obstruct the operator's view resulting in the machine being operated in an unsafe manner.

One rider is permitted, since the machine is equipped with a factory-approved passenger seat.



ZX, PASSENGER -19-02OCT91

T5253 -UN-23AUG88



ROAD SAFETY SWITCH

IMPORTANT: Before driving combine on public roads, make sure that road safety switch is in road position. Also move harvesting unit and unloading auger to transport position.

This ensures that all hydraulic functions — with exception of the steering system — are not working.

ZX 002418

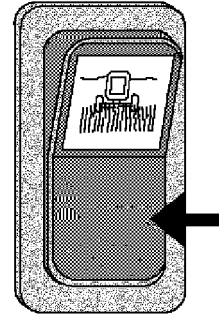

ZX,SWITCHXZCO -19-01MAR95

ZX002418 -UN-16JUN95

EMERGENCY EXIT

The right-hand cab window may be used as an emergency exit. Disengage the gas-filled spring on the sidewall of the cab and open the window.

ZX 006004

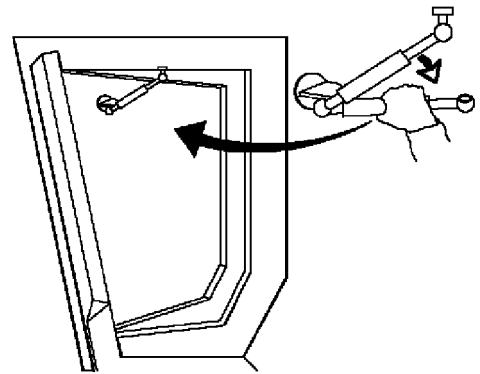

ZX,OMSPFH003293-19-01MAY94

ZX006004 -UN-03APR95



DRIVING THE COMBINE

Operate machine only when all guards are correctly installed.

Before moving away, always check immediate vicinity of machine (e.g. for children). Ensure adequate visibility. Use the horn as a warning immediately before moving away.

Always adapt ground speed to road or field conditions. Avoid making sharp turns when driving up or down slopes or when driving across a slope. Be especially careful when turning on slopes with full grain tank.

Attach harvesting units and other implements to combine with extreme care.

When making turns, always take into consideration the width of the attachment and the fact that the rear end of the combine swings out. Attachments and ground conditions affect the driving characteristics of the combine.

Reduce ground speed when driving on slopes or over uneven ground and before making sharp turns. Before descending a steep hill, shift to a lower gear.

Avoid holes, ditches and obstructions which may cause the combine to tip, particularly on hillsides.

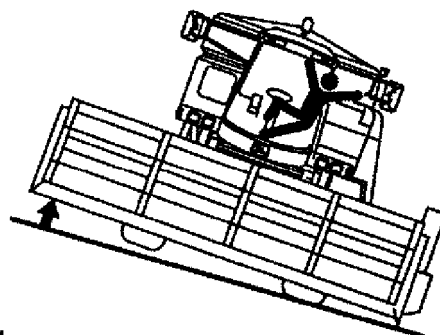

ZX002461

ZX002461 -JUN-16-JUN95

ZX,DRIVEXZCO -19-27JAN92

GUARDS AND SHIELDS

Keep guards and shields in place at all times. Ensure that they are serviceable and installed correctly.

Always disengage main clutch, shut off engine and remove key before removing any guards or shields.

Keep hands, feet and clothing away from moving parts.

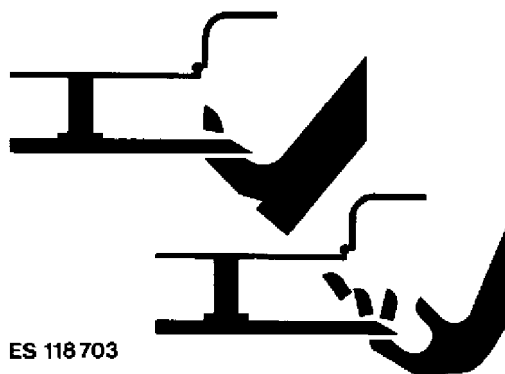

ES 118 703

ES118703 -JUN-21-MAR95

FX,DEVICE -19-04DEC90



STAY CLEAR OF HARVESTING UNITS

Cutterbar, auger, reel and feed rolls cannot be completely shielded due to their function. Stay clear of these moving elements during operation. Always disengage main clutch, shut off engine and remove key before servicing or unclogging machine.



ES 118 704

FX,CUT -19-21DEC90

ES118704 -UN-21MAR95

STAY CLEAR OF ROTATING DRIVELINES

Entanglement in rotating driveline can cause serious injury or death.

Keep tractor master shield and driveline shields in place at all times. Make sure rotating shields turn freely.

Wear close fitting clothing. Stop the engine and be sure PTO driveline is stopped before making adjustments, connections, or cleaning out PTO driven equipment.



DX,PTO -19-12SEP95

TS1844 -UN-22AUG95

TRANSPORT WITH HARVESTING UNIT INSTALLED

Before driving combine on public roads, harvesting unit must be raised and secured in this position. It must not, however, obstruct operator's view of the road. Remove crop dividers (if equipped) and install protective cover.

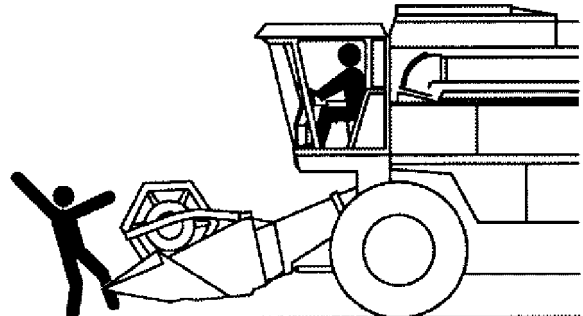

ZX002462

ZX,HEADERXZCO -19-27JAN92

ZX002462 -UN-16JUN95

BALLASTING FOR SAFE GROUND CONTACT

Operating, steering and braking performance of the combine can be considerably affected by attachments which alter the center of gravity of the machine. To maintain safe ground contact, ballast the combine at the rear end as necessary. Observe the maximum permissible axle loads and total weights.

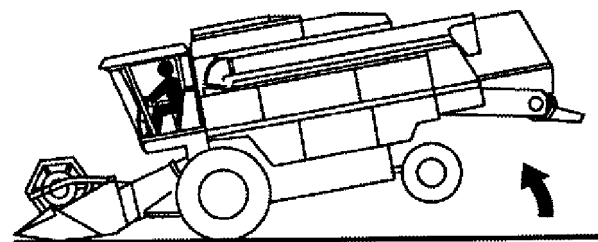

ZX002463

ZX,WEIGHTXZCO -19-27JAN92

ZX002463 -UN-16JUN95



RADIO AERIAL

If radio aerial is not secured in its transport position before driving on public roads, it may come into contact with low-hanging electrical cables. This would result in the operator suffering a severe electrical shock.

To avoid electrical shock, no portion of the machine should be higher than 4 m.

Before transporting machine, bend aerial or remove it.

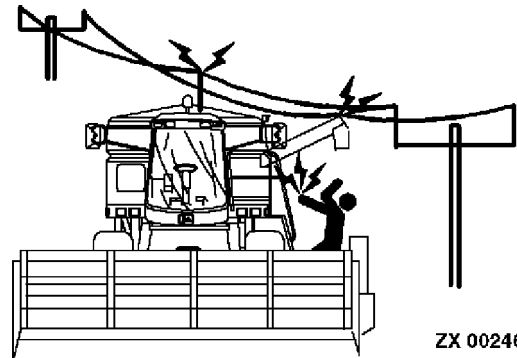

ZX002464 -UN-16JUN95

ZX,ANTENNAZCO -19-27JAN92

PARKING AND LEAVING THE COMBINE

Lower harvesting unit to the ground.

Before leaving the combine, disengage harvesting unit and separator. Shut off engine and move gear shift lever to neutral. Apply parking brake, remove key and lock the operator's cab. Position chock blocks.

NOTE: Use only chock blocks provided with the machine.

Never leave combine unattended as long as engine is running.

Never leave the operator's cab when driving.

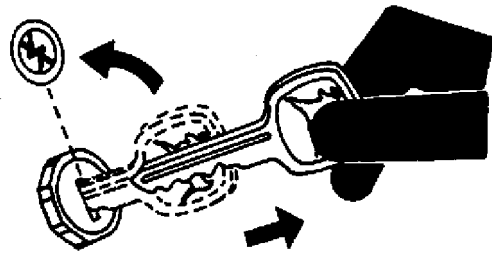

TS230 -UN-24MAY89

ZX,PARKXZCO -19-13APR92

WORK IN VENTILATED AREA

Engine exhaust fumes can cause sickness or death. If it is necessary to run an engine in an enclosed area, remove the exhaust fumes from the area with an exhaust pipe extension.

If you do not have an exhaust pipe extension, open the doors and get outside air into the area.

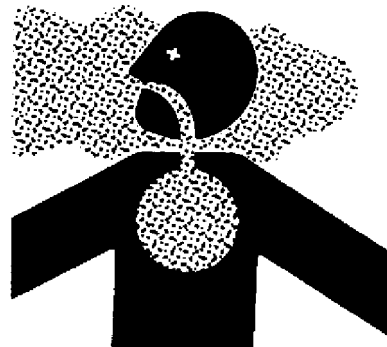

DX,AIR -UN-23AUG88

TS220 -19-04JUN90



PRACTICE SAFE MAINTENANCE

Understand service procedure before doing work. Keep area clean and dry.

Never lubricate, service, or adjust machine while it is moving. Keep hands, feet, and clothing from power-driven parts. Disengage all power and operate controls to relieve pressure. Lower equipment to the ground. Stop the engine. Remove the key. Allow machine to cool.

Securely support any machine elements that must be raised for service work.

Keep all parts in good condition and properly installed. Fix damage immediately. Replace worn or broken parts. Remove any buildup of grease, oil, or debris.

Disconnect battery ground cable (-) before making adjustments on electrical systems or welding on machine.



DX,SERV -19-03MAR93

-UN-23AUG88

TS218

SERVICE MACHINES SAFELY

Tie long hair behind your head. Do not wear a necktie, scarf, loose clothing, or necklace when you work near machine tools or moving parts. If these items were to get caught, severe injury could result.

Remove rings and other jewelry to prevent electrical shorts and entanglement in moving parts.

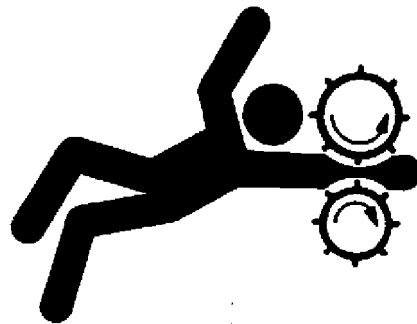

DX,LOOSE -19-04JUN90

-UN-23AUG88

TS228



Suggest:

For more complete manuals. Please go to the home page.

<https://www.ebooklibonline.com>

If the above button click is invalid. Please download this document first, and then click the above link to download the complete manual.

Thank you so much for reading



SUPPORT MACHINE PROPERLY

Always lower the attachment or implement to the ground before you work on the machine. If you must work on a lifted machine or attachment, securely support the machine or attachment.

Do not support the machine on cinder blocks, hollow tiles, or props that may crumble under continuous load. Do not work under a machine that is supported solely by a jack. Follow recommended procedures in this manual.

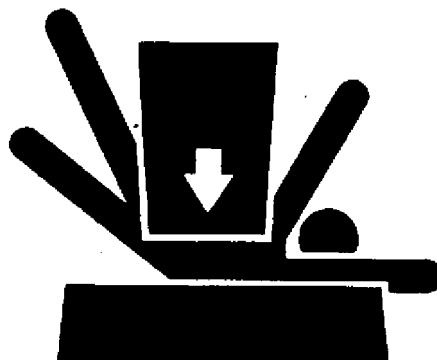

DX,LOWER -19-04JUN90

-UN-23AUG68
TS229

RETORQUE WHEEL NUTS

Retorque wheel nuts as specified in Sections "Wheels and Ballast" and "Lubrication, Periodic Services". Failure to do this could result in a wheel falling off during operation, causing the machine to tip over with serious injury to the operator and extensive damage to the machine.

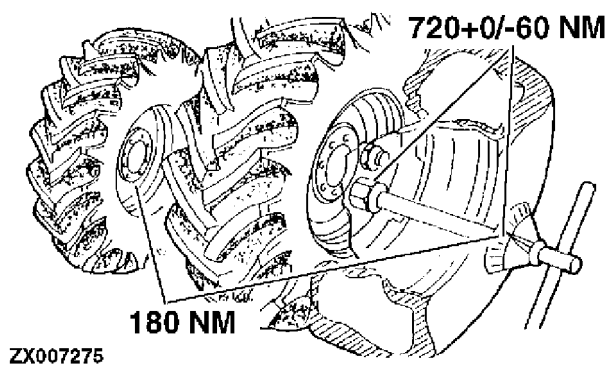

ZX,NUTS -19-01MAR95

-UN-19JUN95
ZX007275



AVOID HIGH-PRESSURE FLUIDS

Escaping fluid under pressure can penetrate the skin causing serious injury.

Avoid the hazard by relieving pressure before disconnecting hydraulic or other lines. Tighten all connections before applying pressure.

Search for leaks with a piece of cardboard. Protect hands and body from high pressure fluids.

If an accident occurs, see a doctor immediately. Any fluid injected into the skin must be surgically removed within a few hours or gangrene may result. Doctors unfamiliar with this type of injury should reference a knowledgeable medical source. Such information is available from Deere & Company Medical Department in Moline, Illinois, U.S.A.

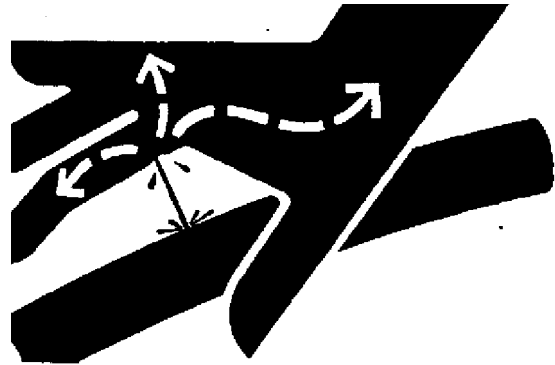

X9811 -UN-23AUG88

DX,FLUID -19-03MAR93

PREVENT BATTERY EXPLOSIONS

Keep sparks, lighted matches, and open flame away from the top of battery. Battery gas can explode.

Never check battery charge by placing a metal object across the posts. Use a volt-meter or hydrometer.

Do not charge a frozen battery; it may explode. Warm battery to 16°C (60°F).



TS204 -UN-23AUG88

DX,SPARKS -19-03MAR93

<https://www.ebooklibonline.com>

Hello dear friend!

Thank you very much for reading.

Enter the link into your browser.

The full manual is available for immediate download.

<https://www.ebooklibonline.com>