

722 Mulch Finisher



OPERATORS MANUAL

722
Mulch Finisher

OMN200113 L7 English

John Deere Des Moines Works
OMN200113 L7

LITHO IN U.S.A.
ENGLISH



Introduction

Read this manual carefully to learn how to operate and service your machine correctly. Failure to do so could result in personal injury or equipment damage.

This manual should be considered a permanent part of your machine and should remain with the machine when you sell it.

Measurements in this manual are U.S. customary units and their metric equivalents.

Right-hand and left-hand sides of the implement are determined by facing in the direction the implement will travel when going forward.

Warranty appears on your copy of the purchase order which you should have received from your dealer.

The tire manufacturer's warranty supplied with your machine may not apply outside the U.S.

Write product identification numbers in the Specifications section. Accurately record all the numbers to help in tracing the machine should it be stolen. Your dealer also needs these numbers when you order parts. If this manual is kept on the machine, also file the identification numbers in a secure place off the machine.

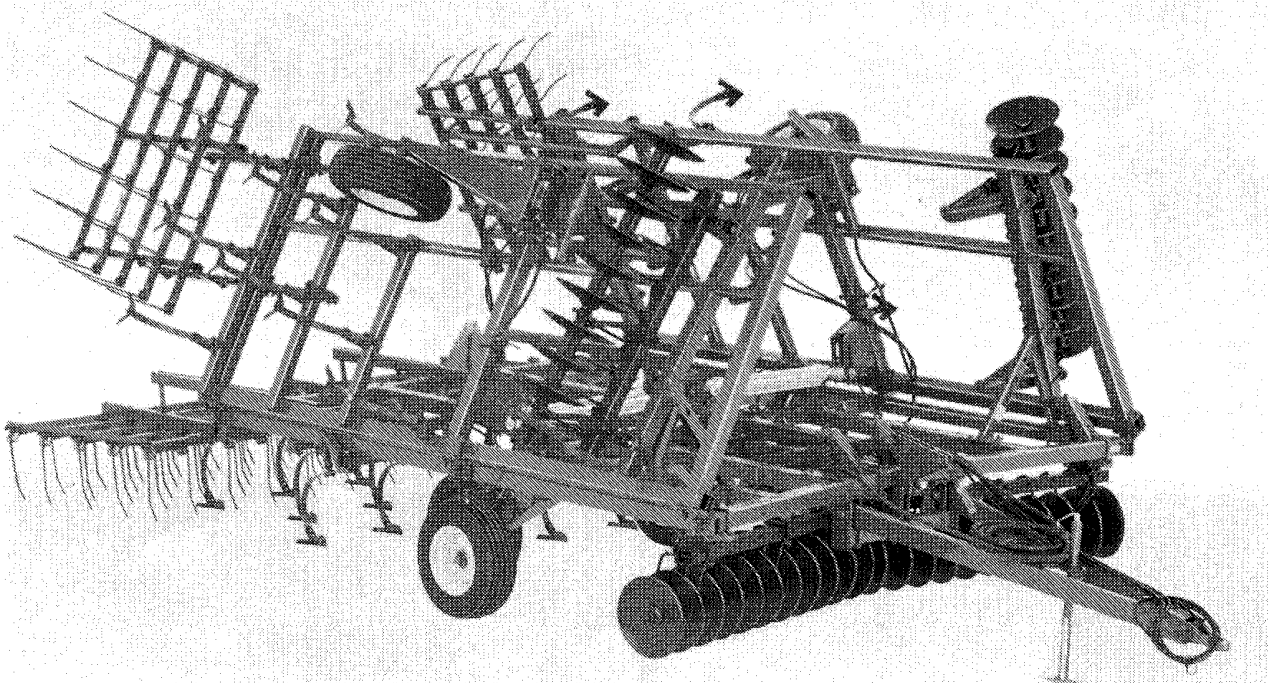

All information, illustrations and specifications in this manual are based on the latest product information available at the time of publication. The right is reserved to make changes at any time without notice.

9A8;N37448 N03;;722A IFC 300686

N66;IFC 3 300487

Contents

	Page		Page
Safety Signs	05-1	Increasing Rigidity of Standards	50-4
Safety	10-1	Removing and Repairing Cylinders	50-5
Preparing the Tractor	15-1	Bleeding Trapped Air	
Preparing the Mulch Finisher	20-1	Mechanical Depth Control and Wing	
Attaching and Detaching	25-1	Lift Cylinders	50-6
Transporting	30-1	Hydraulic Depth Control -Series	
Operating the Mulch Finisher		Cylinders	50-7
Guidelines	35-1	Identifying Disk Blades Eligible	
Lowering Wings from Transport to		for Warranty	50-8
Field Position	35-1	Identifying Disk Blades not Eligible	
Raising Wings from Field to Transport		for Warranty	50-9
Position	35-2	Replacing Sweeps	50-12
Leveling Mulch Finisher	35-2	Storage	55-1
Adjusting Depth Control (Mechanical)	35-3	Crime Prevention Tips	60-1
Adjusting Depth Control (Hydraulic)	35-3	Specifications	
Hydraulic Depth Control System (Series)	35-4	Serial Number	65-3
Positioning			
Disk Scrapers for Rigid Operation	35-5		
Disk Scrapers for Self-Adjusting			
Operation	35-5		
Adjusting			
Spring Pressure of Disk Gangs	35-5		
Disk Gang Height	35-6		
Stabilizer Wheel Down Pressure	35-6		
Leveling Wings and Adjusting Wing			
Stops	35-7		
Adjusting			
Coil Tine Tooth Harrow Spring Tension	35-8		
Coil Tine Tooth Harrow Height	35-8		
Spike Tooth Drag Harrow Angle	35-9		
Spike Tooth Drag Harrow Height	35-9		
Nozzle Height and Spacing for Spray			
Attachment	35-10		
Lubrication and Maintenance	40-1		
Troubleshooting	45-1		
Service			
Tightening Hardware	50-1		
Wheel Bolts and Wheel Bearings	50-2		
Torque on Disk Gang Hardware	50-2		
Tightening Gang Bolts	50-3		
Gang Bolt Wrenches	50-3		
Setting Torque on Spring-Trip Standards	50-4		

<https://www.ebooklibonline.com>

Hello dear friend!

Thank you very much for reading.

Enter the link into your browser.

The full manual is available for immediate download.

<https://www.ebooklibonline.com>

Safety Signs

RECOGNIZE SAFETY INFORMATION

This is the safety-alert symbol. When you see this symbol on your machine or in this manual, be alert to the potential for personal injury.



AB6;T81389 053;ALERT 071085

FOLLOW SAFETY INSTRUCTIONS

Carefully read all safety messages in this manual and on your machine safety signs. Follow recommended precautions and safe operating practices.

Keep safety signs in good condition. Replace missing or damaged safety signs.



AB6;TS188 053;SIGNS 071085

UNDERSTAND SIGNAL WORDS

A signal word—DANGER, WARNING, or CAUTION—is used with the safety-alert symbol. DANGER identifies the most serious hazards.

Safety signs with signal word DANGER or WARNING are typically near specific hazards.

General precautions are listed on CAUTION safety signs. CAUTION also calls attention to safety messages in this manual.



▲WARNING

▲CAUTION

AB6;TS187 053;SIGNAL 071085

Replacement kits are available from your John Deere dealer. Use the following illustrations to locate signs on your machine.

N01;;7445T A 080186



WARNING

1. Stop machine to raise and lower outriggers.
2. Secure raised outriggers with locking pins before transporting and before detaching lift cylinder or its hydraulic hoses.
3. Stay clear of outriggers during raising and lowering.
4. Install flow restrictors in cylinders for outrigger lift.

CA

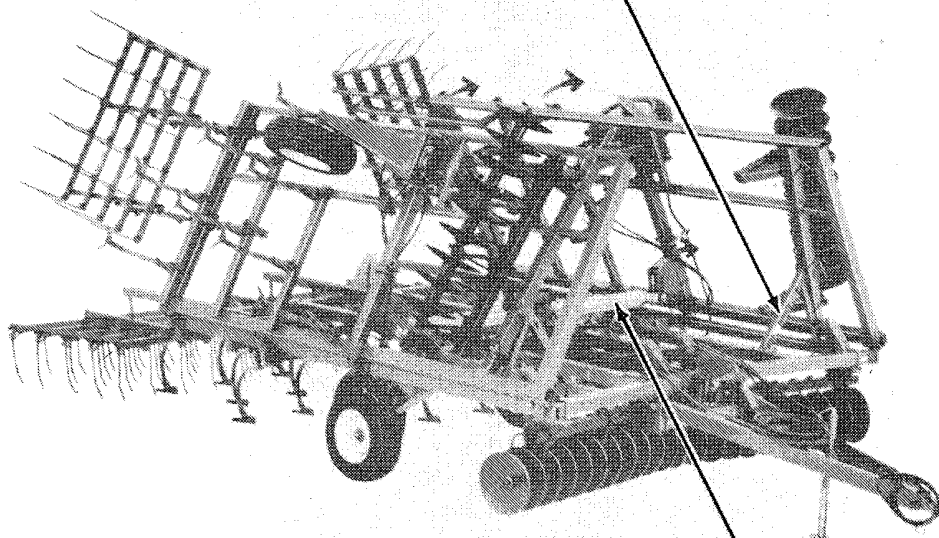

WARNING

Be sure cylinder and attaching hoses are fully charged with oil before operating system. Failure to do so will allow outriggers to fall rapidly when attempting to lower from transport position.

DL

Safety

LEARN MACHINE SAFETY

Carefully read this manual. Learn how to operate the machine and how to use the controls properly.

Do not let anyone operate this machine without proper instruction.

Unauthorized modifications to the machine may impair the function and/or safety and affect machine life.



AB6;TS183 053;READ2 080785

OPERATE SAFELY

DO NOT allow anyone to ride on the machine when it is in motion.

Always shut off tractor engine and shift to "Park" when leaving tractor. Remove key when leaving tractor unattended.

DO NOT operate close to a ditch or creek.

Slow down when turning.

Drive slowly over rough ground.

Apply both tractor brakes evenly when making emergency stops. Plan ahead.

Wear relatively tight and belted clothing to prevent being caught on some part of the machine.

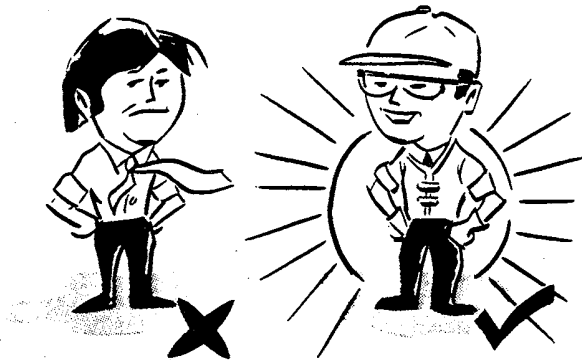

9A8;E19363 N03;722 SAA 230883

AVOID FIRES

DO NOT refuel with the tractor engine running.

DO NOT smoke or use a lantern when refueling.

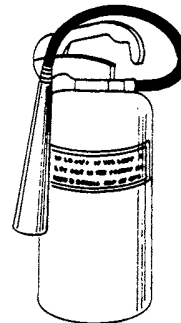

9A8;N35540 N03;;712 SAD 040283



Suggest:

For more complete manuals. Please go to the home page.

<https://www.ebooklibonline.com>

If the above button click is invalid. Please download this document first, and then click the above link to download the complete manual.

Thank you so much for reading

PROTECT AGAINST NOISE

Prolonged exposure to loud noise can cause impairment or loss of hearing.

Wear a suitable hearing protective device such as earmuffs (A) or earplugs (B) to protect against objectionable or uncomfortable loud noises.

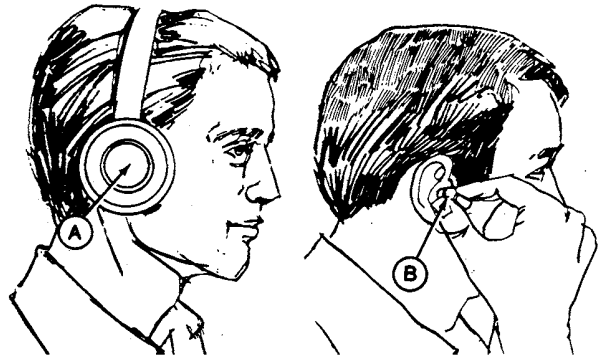

AB6;X7662 053;NOISE 270886

USE SAFETY LIGHTS AND DEVICES

When transporting your machine on a road or highway at night or during the day, use necessary safety lights. Check local governmental regulations. A safety lighting kit is available from your John Deere dealer.

Keep safety items in good condition. Replace missing or damaged items.

A—Lights
B—SMV Emblem

C—Reflector Tape
D—Reflectors

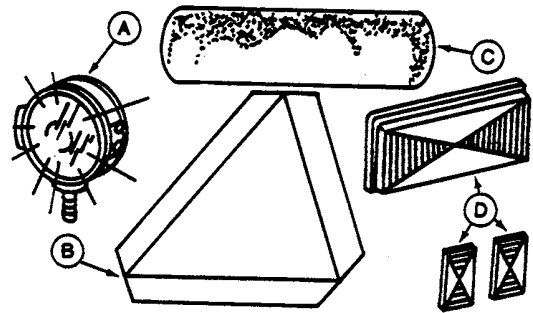

AB6;N36564 053;WARN 111085

TRANSPORT SAFELY

DO NOT fail to latch tractor brakes together.

Shift tractor into a lower gear when transporting down steep slopes or hills.

Stop slowly.

KNOW the transport height and width of your machine and beware of overhead wires.

Keep the SMV emblem and reflectors clean and visible from the rear.

Fold outriggers and install lockup pins in the transport position.

DO NOT exceed the maximum transport speed of 10 mph (16 km/h). Reduce speed when traveling over rough ground.

H35338

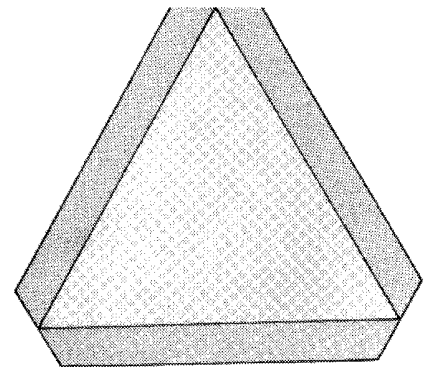

9A8;H35338 N03;;722C B 080785

POSITION MECHANICAL CYLINDER LOCKUP BRACKETS IN TRANSPORT POSITION

For 12 ft 8-in., 15 ft 4-in., and 19 ft 4-in. (3.9, 4.7 and 5.9 m) Models, pin cylinder lockup brackets (A) in transport position. Use both cylinder lockup brackets to avoid machine damage.

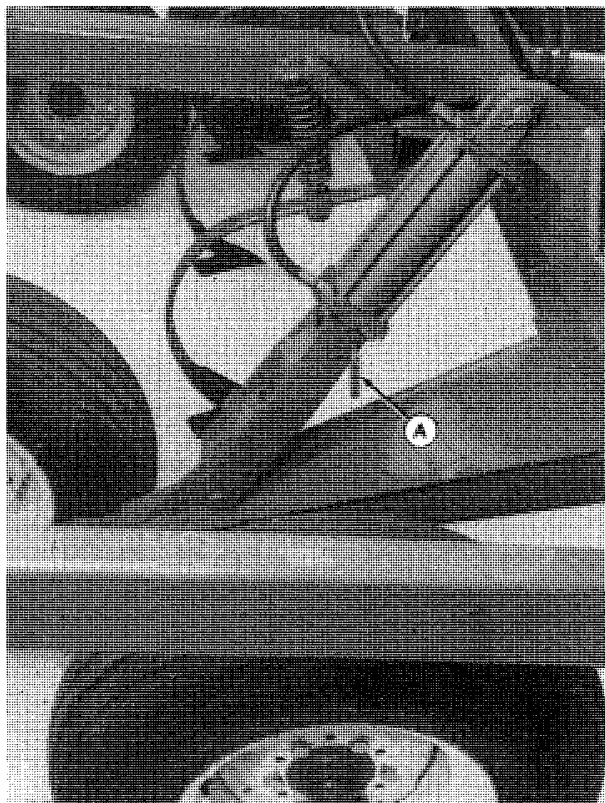

9A8;N83169 P1 N03;722 SAC 230883

POSITION HYDRAULIC CYLINDER STOPS IN TRANSPORT POSITION

For 24 ft 8-in. and 30 ft (7.5 and 9.2 m) Models, move cylinder depth control stop (A) forward to lock cylinder in place. Use both cylinder stops to avoid machine damage.

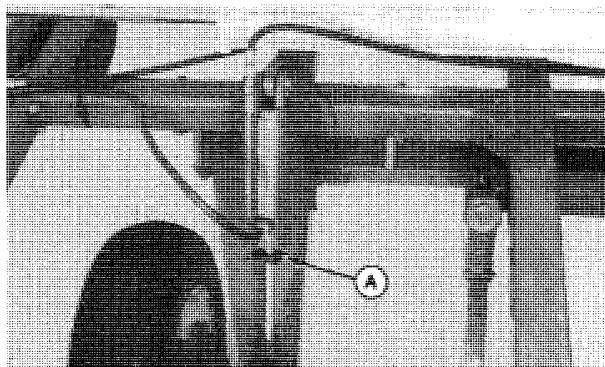

9A8;N83172 M1 N03;722 SAD 230883

FOLDING MODELS ONLY—INSTALL OUT-RIGGER LOCKUP PINS

When transporting, move lockup pins from field position (B) to transport position (A).

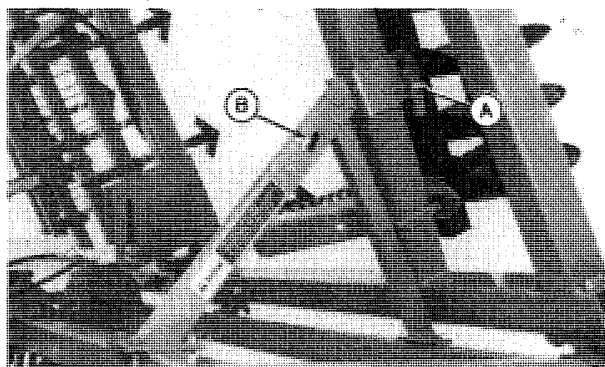

9A8;N83172 I1 N03;722 SAE 150883

<https://www.ebooklibonline.com>

Hello dear friend!

Thank you very much for reading.

Enter the link into your browser.

The full manual is available for immediate download.

<https://www.ebooklibonline.com>