

KEY	PART NO.	PART NAME	QTY	REMARKS	
1	REC368634400	FILLER NECK	1		
2	REC368793200	FILLER CAP	1		
3	REC286922000	RETAINER	1		
4	REC368570100	O-RING	1		
5	REC390311200	SCREW	2		
6	REC368646800	BRACE	1		
7	REC390062900	CAP SCREW	3		
8	REC390399000	CAP SCREW	2		
9	REC368037100	PLATE	1		
10	REC310411900	GASKET	1		

<https://www.ebooklibonline.com>

Hello dear friend!

Thank you very much for reading.

Enter the link into your browser.

The full manual is available for immediate download.

<https://www.ebooklibonline.com>

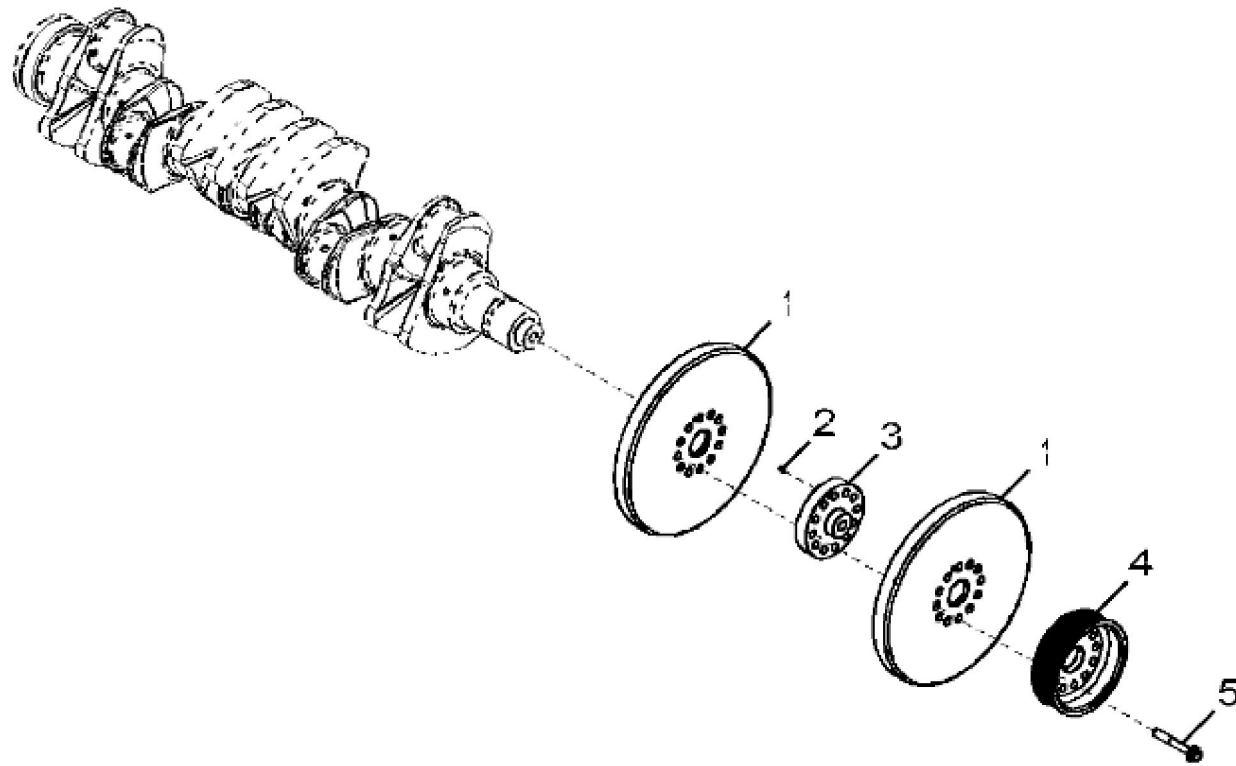

1355_ETN129947_PCD

KEY	PART NO.	PART NAME	QTY	REMARKS	
1	REC410188400	TORSIONAL DAMPER	2		
2	REC306893500	DOWEL PIN	2		
3	REC368159500	SPACER	1		
4	REC310137600	PULLEY	1		
5	REC368158300	CAP SCREW	12		

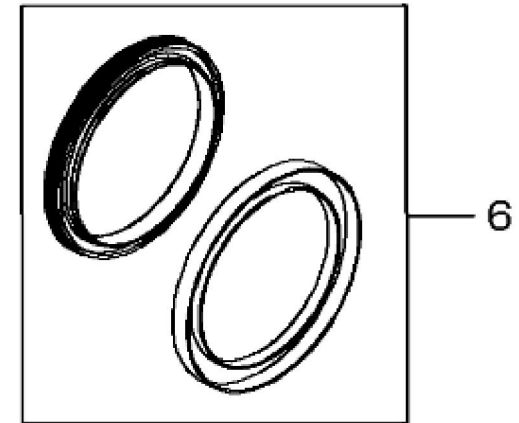
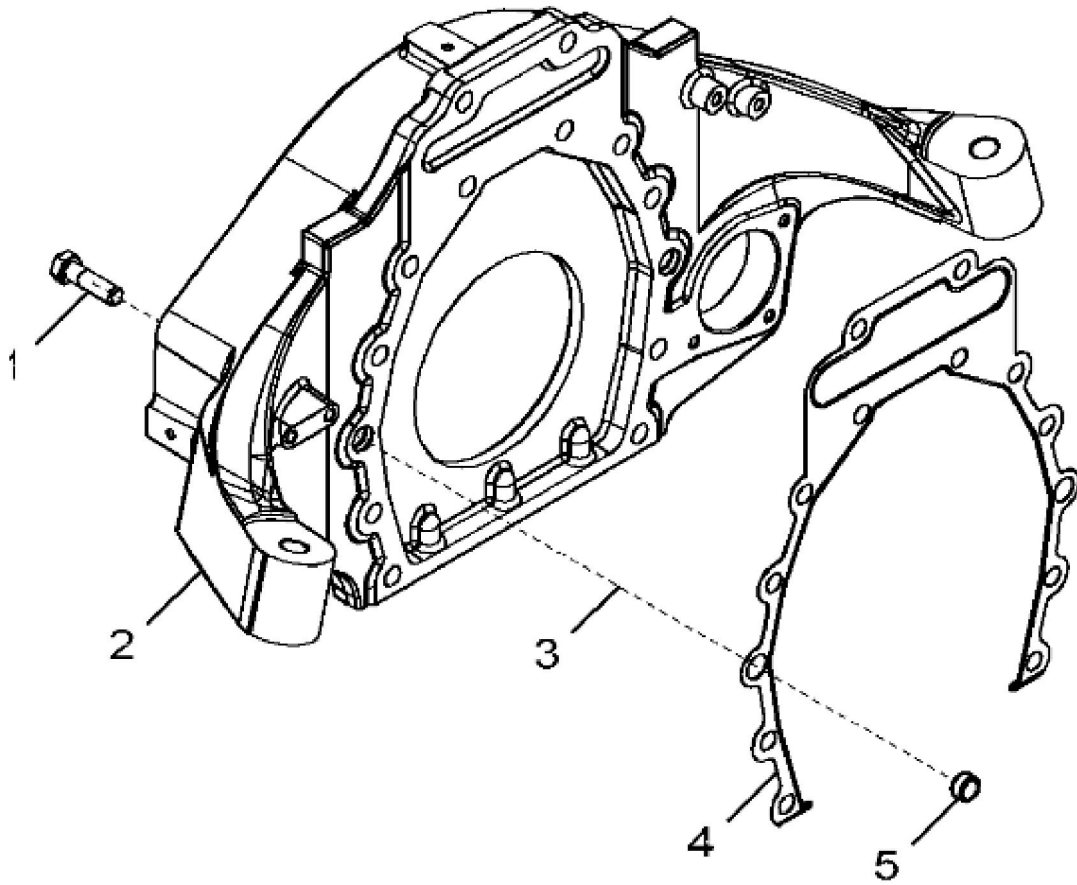



Suggest:

For more complete manuals. Please go to the home page.

<https://www.ebooklibonline.com>

If the above button click is invalid. Please download this document first, and then click the above link to download the complete manual.

Thank you so much for reading

KEY	PART NO.	PART NAME	QTY	REMARKS	
1	REC302214800	CAP SCREW	14		
2	REC369100400	SUPPORT	1	SUB FOR REC368988600	
3	REC012731600	WASHER	14		
4	REC496568800	GASKET	1		
5	REC367887100	DOWEL PIN	2		
6	REC496556900	SEAL KIT	1		

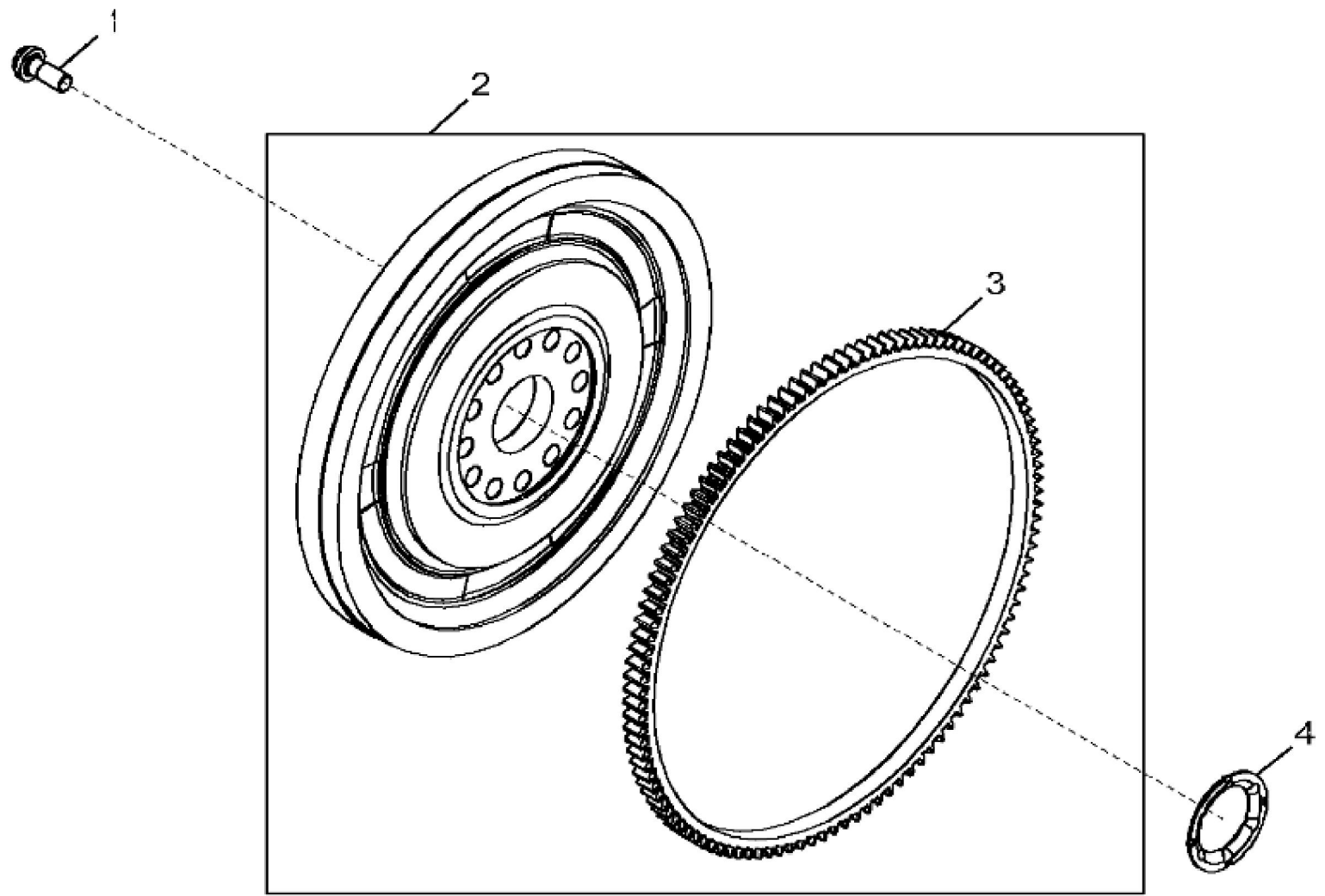

1527_ETN129949_PCD

<https://www.ebooklibonline.com>

Hello dear friend!

Thank you very much for reading.

Enter the link into your browser.

The full manual is available for immediate download.

<https://www.ebooklibonline.com>