

KEY	PART NO.	PART NAME	QTY	REMARKS
1	19M7867	SCREW	21	M8 X 25
2	RE517370	FITTING	1	
3	51M7044	O-RING	1	17.300 X 2.200 mm
4	RE544546	PANEL	1	
5	R531582	GASKET	1	
6	RE555124	PANEL	1	ORDER RE555917; USE WITH (2) R531581, RE549027 AND RE555125
6	RE555917	PANEL	1	USE WITH R531581, RE555123 AND R538268; SUB FOR RE555124
7	R531581	GASKET	1	
8	19M7913	SCREW	15	M8 X 90
9	RE547944	SLEEVE	15	
10	24H1341	WASHER	1	17/32" X 15/16" X 0.060"
11	RE549027	VALVE COVER	1	ORDER RE555123; USE WITH (2) R531581, RE555124 AND RE555125; SUB FOR RE544630
11	RE555123	VALVE COVER	1	USE WITH R531581, RE555917 AND R538268; SUB FOR RE549027 OR RE549028 OR RE544845; INCLUDES (2) R501292 AND R529889
12	R501292	GROMMET	2	
13	R116713	NEEDLE ROLLER	2	
14	RE555125	PANEL	1	ORDER R538268; USE WITH (2) R531581, RE549027 AND RE555124
14	R538268	PANEL	1	USE WITH R531581, RE555123 AND RE555917; SUB FOR RE555125
15	19M6614	CAP SCREW	3	M6 X 12
16	R529889	GASKET	1	
17	RE553618	WIRING HARNESS	1	SUB FOR RE544716
18	R532550	O-RING	1	
19	R521299	SOCKET HEAD SCREW	6	
20	57M10901	CLAMP	3	
21	57M10900	CLAMP	1	
22	57M10899	CLAMP	2	
23	R531333	CLIP	1	

<https://www.ebooklibonline.com>

Hello dear friend!

Thank you very much for reading.

Enter the link into your browser.

The full manual is available for immediate download.

<https://www.ebooklibonline.com>

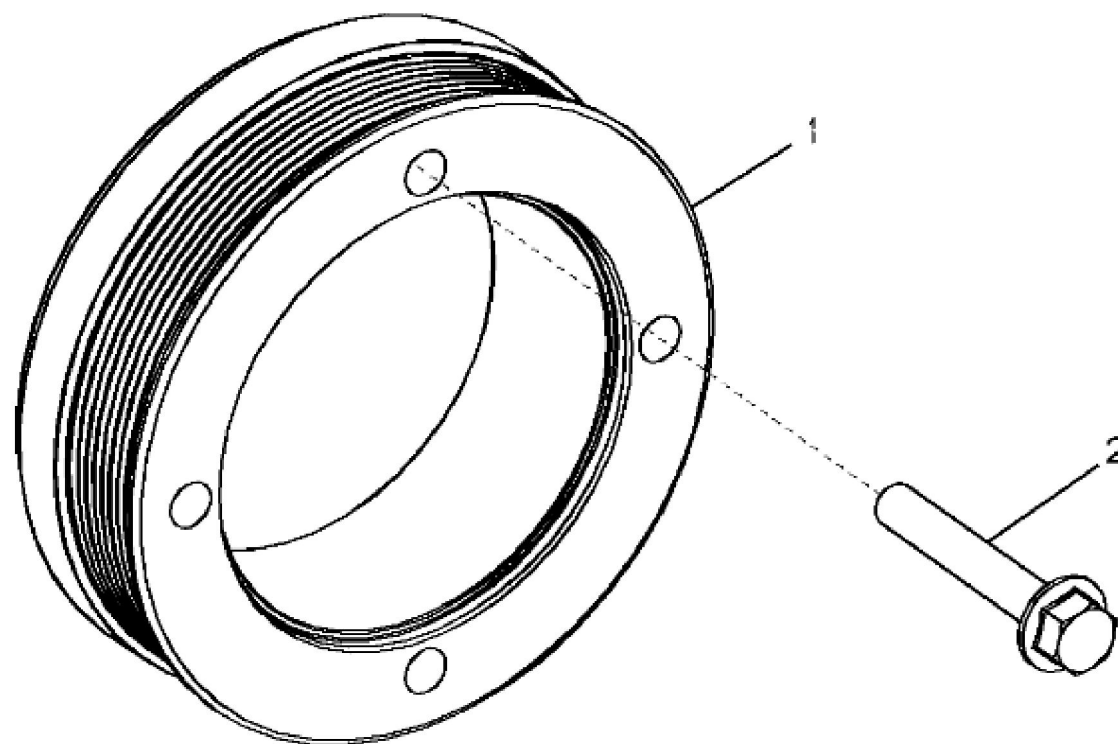

1352_RE548209_PCD

KEY	PART NO.	PART NAME	QTY	REMARKS	
1	R533628	PULLEY	1	MARKED R529123	
2	19M9040	SCREW	4	M12 X 75	

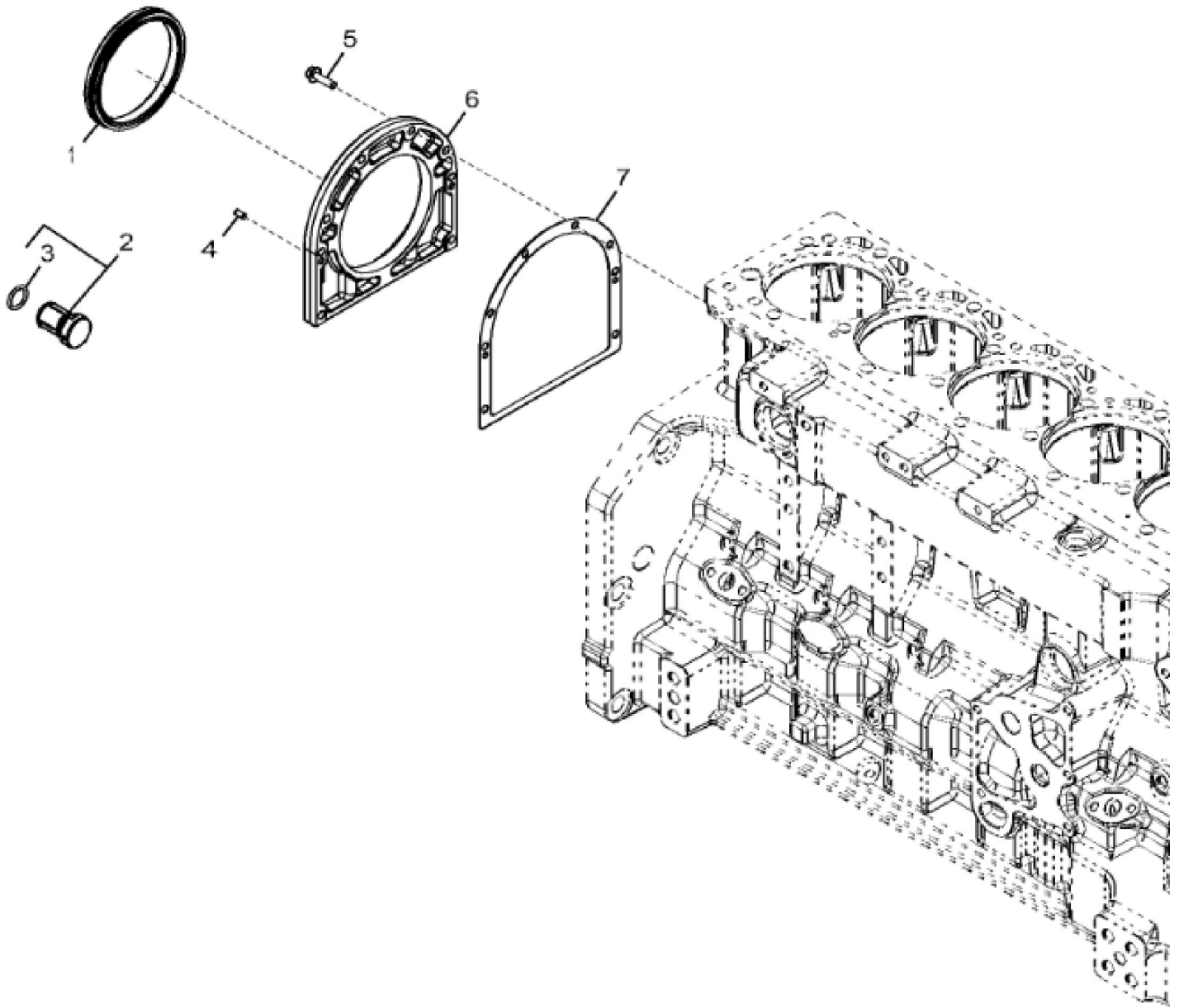



Suggest:

For more complete manuals. Please go to the home page.

<https://www.ebooklibonline.com>

If the above button click is invalid. Please download this document first, and then click the above link to download the complete manual.

Thank you so much for reading

KEY	PART NO.	PART NAME	QTY	REMARKS	
1	RE535552	SEAL	1		
2	AR61533	PLUG	1		
3	R27149	O-RING	1		
4	F1743R	DOWEL PIN	2		
5	19M7868	SCREW	8	M8 X 30	
6	DZ100355	HOUSING	1	MARKED DZ100356 OR DZ100355; SUB FOR R529914	
7	R530027	GASKET	1		

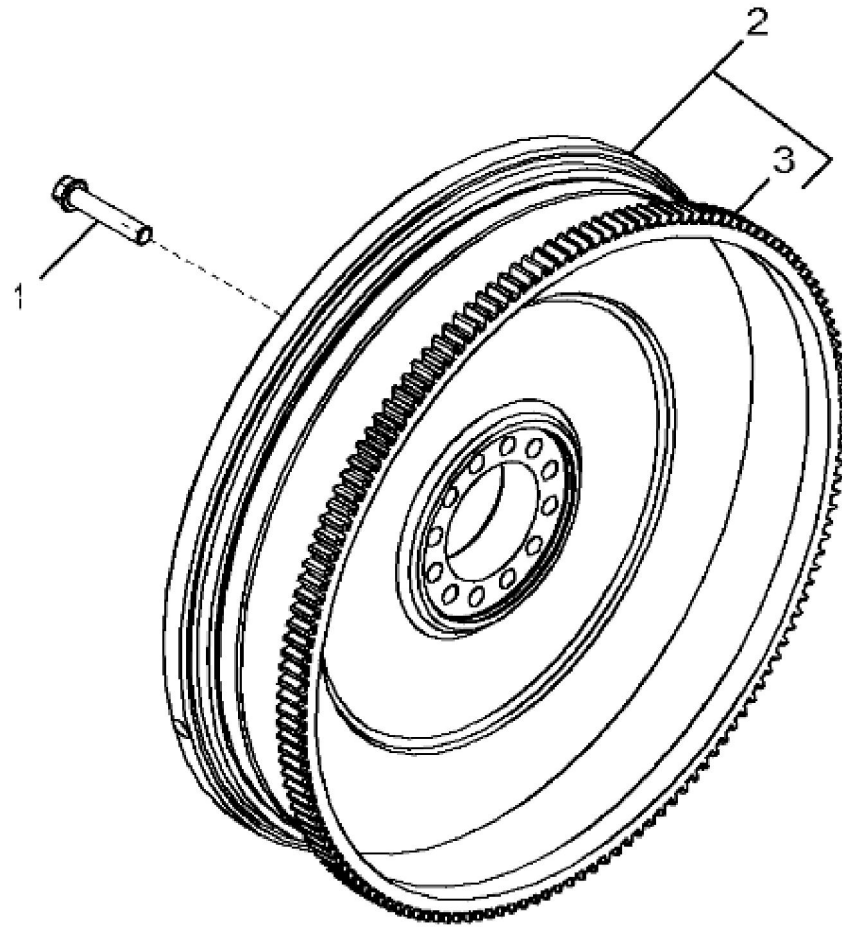

1518_RG25655_PCD

<https://www.ebooklibonline.com>

Hello dear friend!

Thank you very much for reading.

Enter the link into your browser.

The full manual is available for immediate download.

<https://www.ebooklibonline.com>