

KEY	PART NO.	PART NAME	QTY	REMARKS	
1	RE529871	ELBOW FITTING	1	SUB FOR RE527976	
2	T122075	O-RING	1		
3	19M8291	SCREW	15	M8 X 35	
4	RE536705	COVER	1	MARKED R545610; SUB FOR RE529972	
5	R523317	BREATHER	1	SUB FOR R518264	
6	RE526690	CAP SCREW	2		
7	RE526689	CAP SCREW	1		
8	R527884	GASKET	1		

<https://www.ebooklibonline.com>

Hello dear friend!

Thank you very much for reading.

Enter the link into your browser.

The full manual is available for immediate download.

<https://www.ebooklibonline.com>

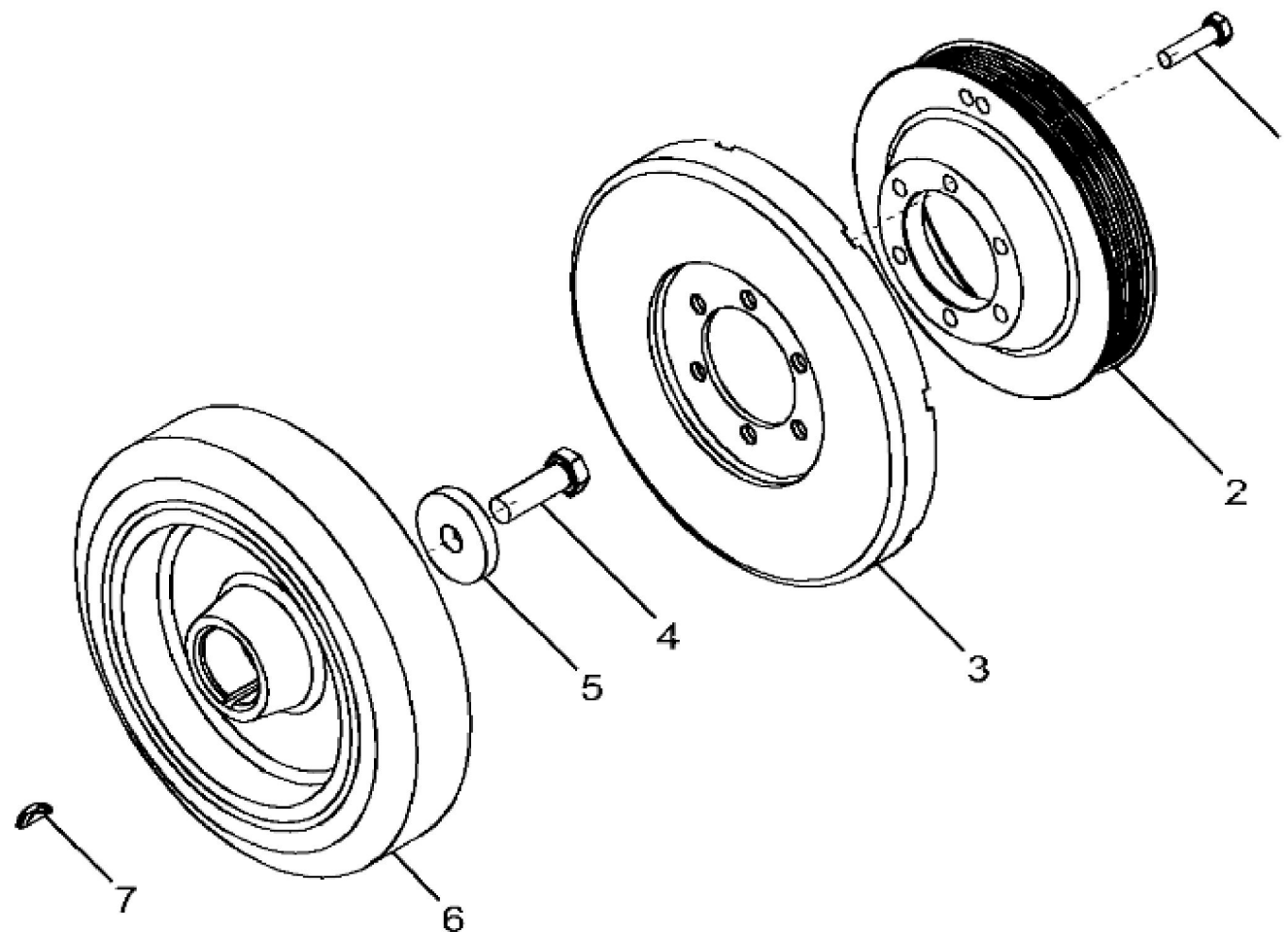

1303_RE523110_PCD

KEY	PART NO.	PART NAME	QTY	REMARKS	
1	19M8637	CAP SCREW	6	M10 X 40	
2	R518277	PULLEY	1		
3	RE57604	TORSIONAL DAMPER	1		
4	19M8889	CAP SCREW	1	M16 X 50	
5	R26333	WASHER	1		
6	RE520465	TORSIONAL DAMPER	1		
7	R523306	KEY	1		

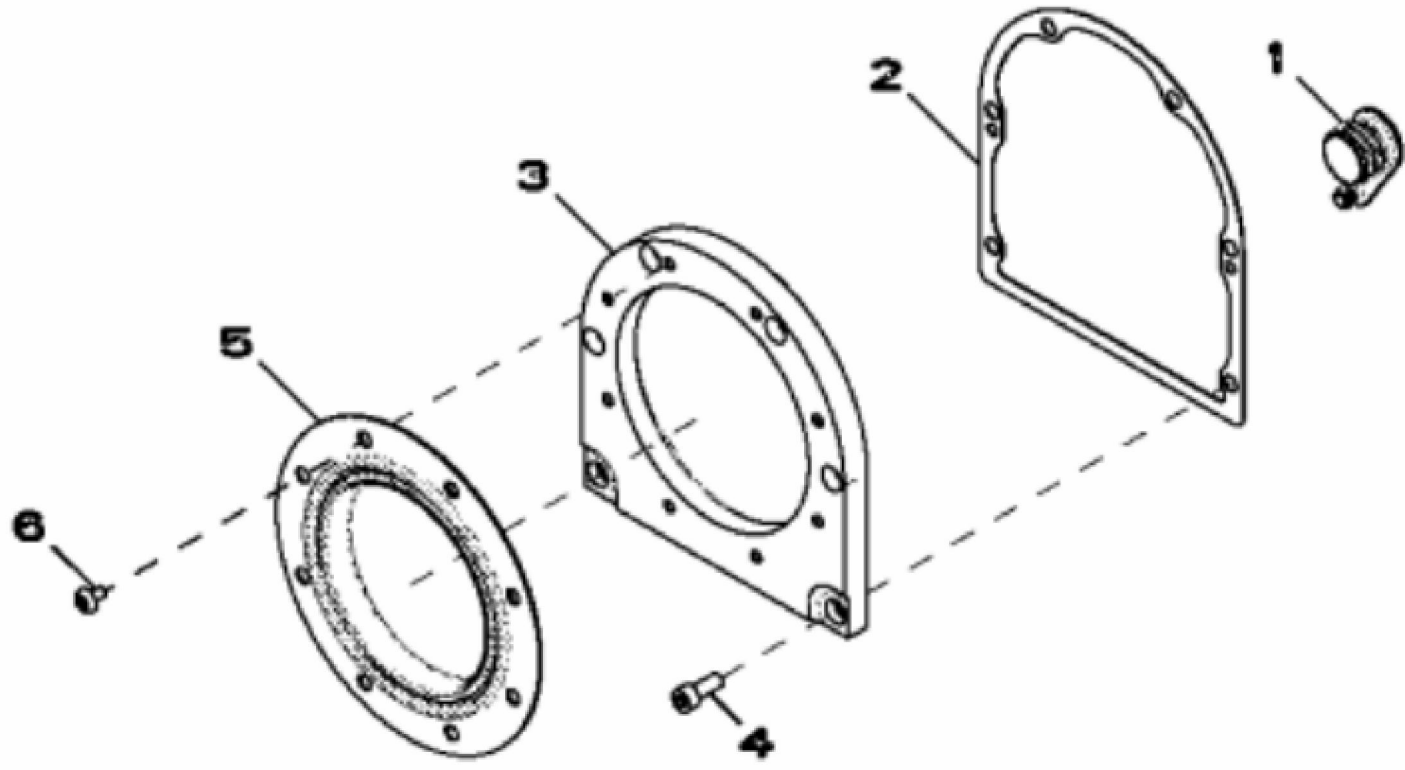

RE534164PCDC02



Suggest:

For more complete manuals. Please go to the home page.

<https://www.ebooklibonline.com>

If the above button click is invalid. Please download this document first, and then click the above link to download the complete manual.

Thank you so much for reading

KEY	PART NO.	PART NAME	QTY	REMARKS	
1	R121929	PLUG	1		
2	R522768	GASKET	1		
3	R530233	HOUSING	1		
4	19M8446	SCREW	6	M8 X 20	
5	RE530121	SEAL	1		
6	R522160	SCREW	8		

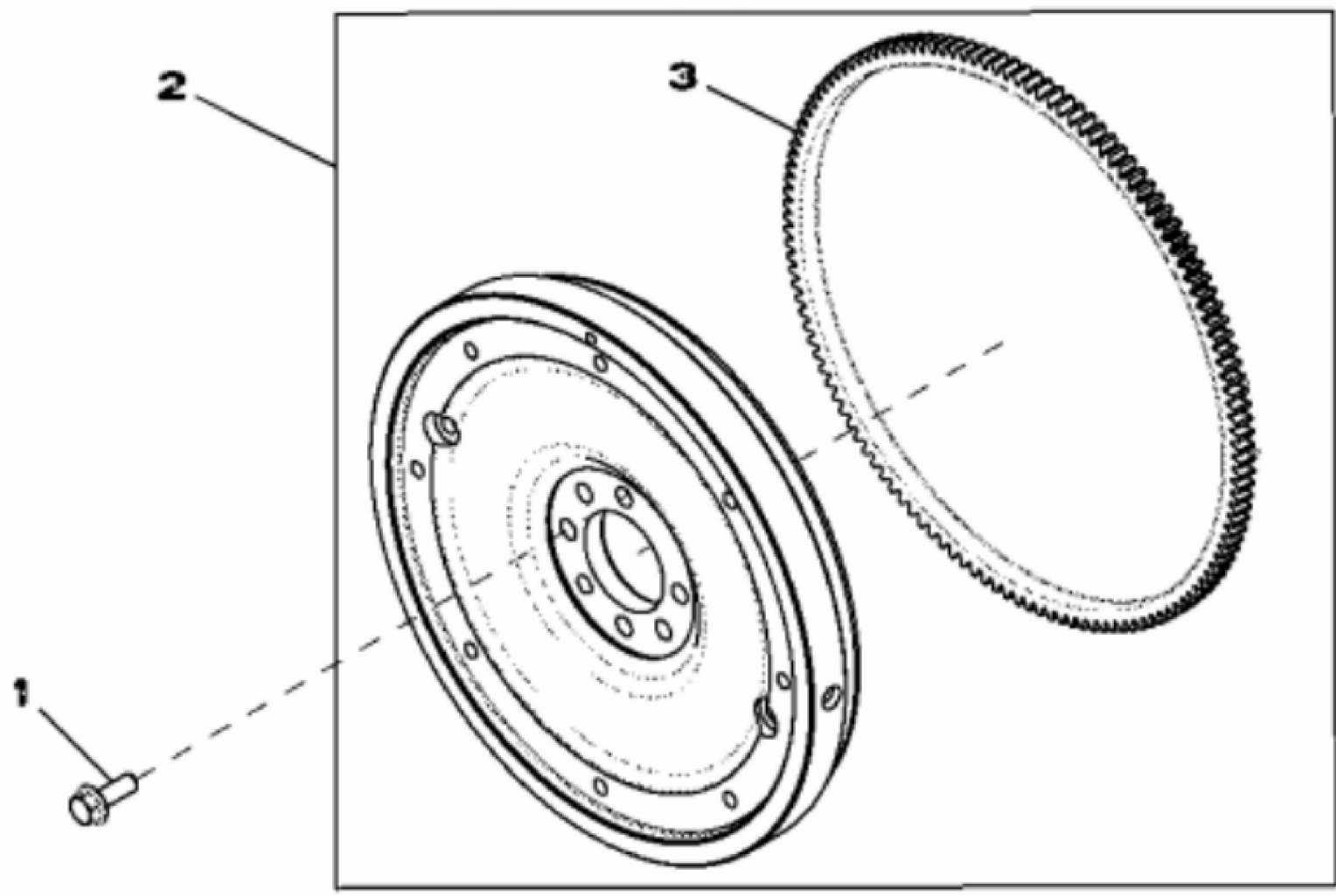

RE522627PCDA02

<https://www.ebooklibonline.com>

Hello dear friend!

Thank you very much for reading.

Enter the link into your browser.

The full manual is available for immediate download.

<https://www.ebooklibonline.com>