

RGP2674

KEY	PART NO.	PART NAME	QTY	Engine Serial No.	REMARKS
1	34H247	SPRING PIN	1		1/8" X 3/4"
2	R49571	SPRING	16		
3	R62530	ROTATOR	16		
4	T20077	RETAINER	32		
5	R61999	DOWEL PIN	8		
6	R40366	CAP	8		
7	PT13309	NUT	8		(SUB FOR R60717)
8	R60582	SCREW	8		
9	AR73480	ARM	8		
10	R63324	BOLT	18		
11	R63325	WASHER	18		
12	R62528	SLEEVE	4		
13	R56751	O-RING	4		
14	15H562	PIPE PLUG	7	____-XXXXXX	1", (SUB FOR AR78522)
14	15H665	PIPE PLUG	3	XXXXXX-____	3/4", (SUB FOR AR72318)
15	R50356	VALVE SEAT INSERT	8		
15	R55061	VALVE SEAT INSERT	8		0.25 MM OS
16	R63078	VALVE SEAT INSERT	8		
16	R68136	VALVE SEAT INSERT	8		0.25 MM OS
17	R75133	GASKET	1		
18	R75134	COVER	1		
19	12M7066	LOCK WASHER	4		10 mm
20	19M7402	CAP SCREW	4		M10 X 25
21	RE10733	CYLINDER HEAD	1		(MARKED R73272) (SUB RG20631)
22	R78445	INTAKE VALVE	8		STD (SUB FOR R63079)
22	R68137	INTAKE VALVE	8		0.075 MM OS
22	R68138	INTAKE VALVE	8		0.50 MM OS
22	R68139	INTAKE VALVE	8		1.00 MM OS
23	R50357	EXHAUST VALVE	8		STD
23	R55056	EXHAUST VALVE	8		0.08 MM OS
23	R55058	EXHAUST VALVE	8		0.38 MM OS
23	R55060	EXHAUST VALVE	8		0.76 MM OS
24	R61296	STUD	8	____-003993	(SUB R82735)
25	RE51641	ENGINE CYLINDER HEAD GASKET	1		(SUB FOR R62409)

<https://www.ebooklibonline.com>

Hello dear friend!

Thank you very much for reading.

Enter the link into your browser.

The full manual is available for immediate download.

<https://www.ebooklibonline.com>

KEY	PART NO.	PART NAME	QTY	Engine Serial No.	REMARKS	
26	RE11270	CYLINDER HEAD	1		(SUB RG20631)	
26	RG20631	CYLINDER HEAD	1		(CONTACT BRANCH AFTERMARKET MANAGER FOR ORDERING DETAILS) (REMANUFACTURED)	

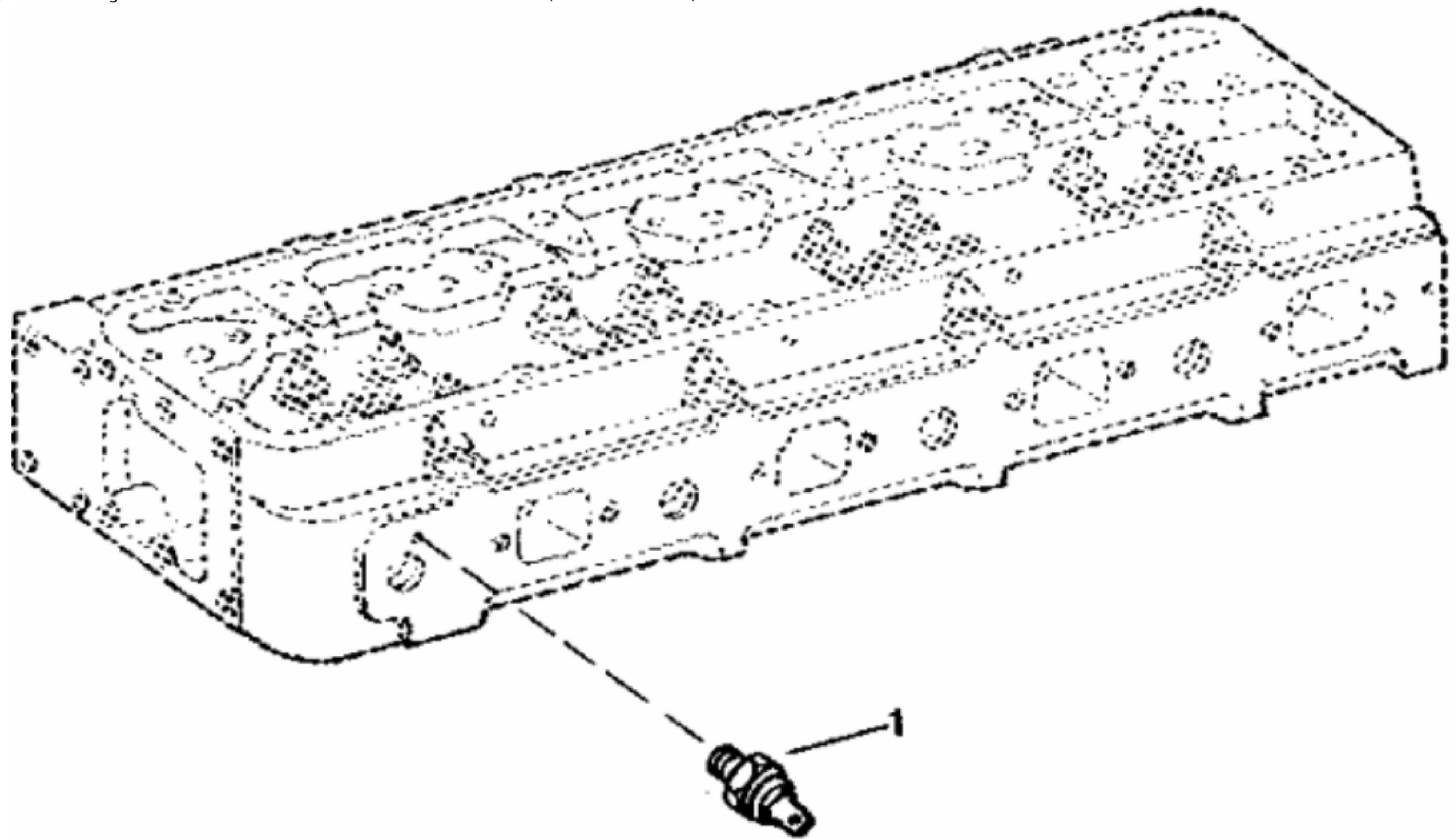

RGP730

KEY	PART NO.	PART NAME	QTY	Engine Serial No.	REMARKS	
1	RE10691	SENSOR	1	____-XXXXXX	(CUT AND TAPE WIRE - BAND TO HARNESS) (SUB 15H584)	
1	15H584	PIPE PLUG	1	XXXXXX-____	1/2"	

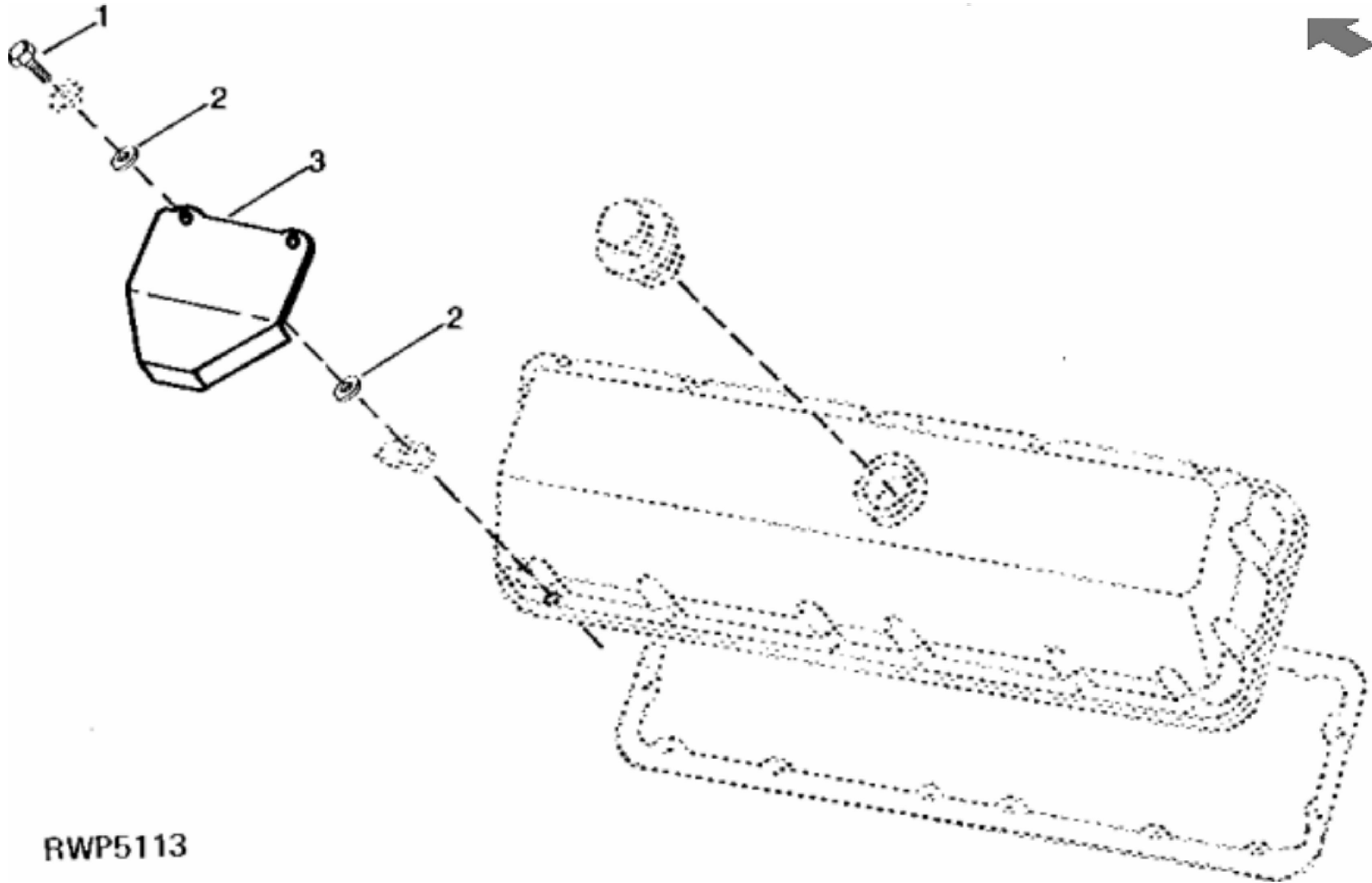

RWP5113



Suggest:

For more complete manuals. Please go to the home page.

<https://www.ebooklibonline.com>

If the above button click is invalid. Please download this document first, and then click the above link to download the complete manual.

Thank you so much for reading

KEY	PART NO.	PART NAME	QTY	REMARKS	
1	19M7163	CAP SCREW	2	M8 X 25	
2	24H1136	WASHER	4	11/32" X 11/16" X 0.065"	
3	R81282	SHIELD	1		

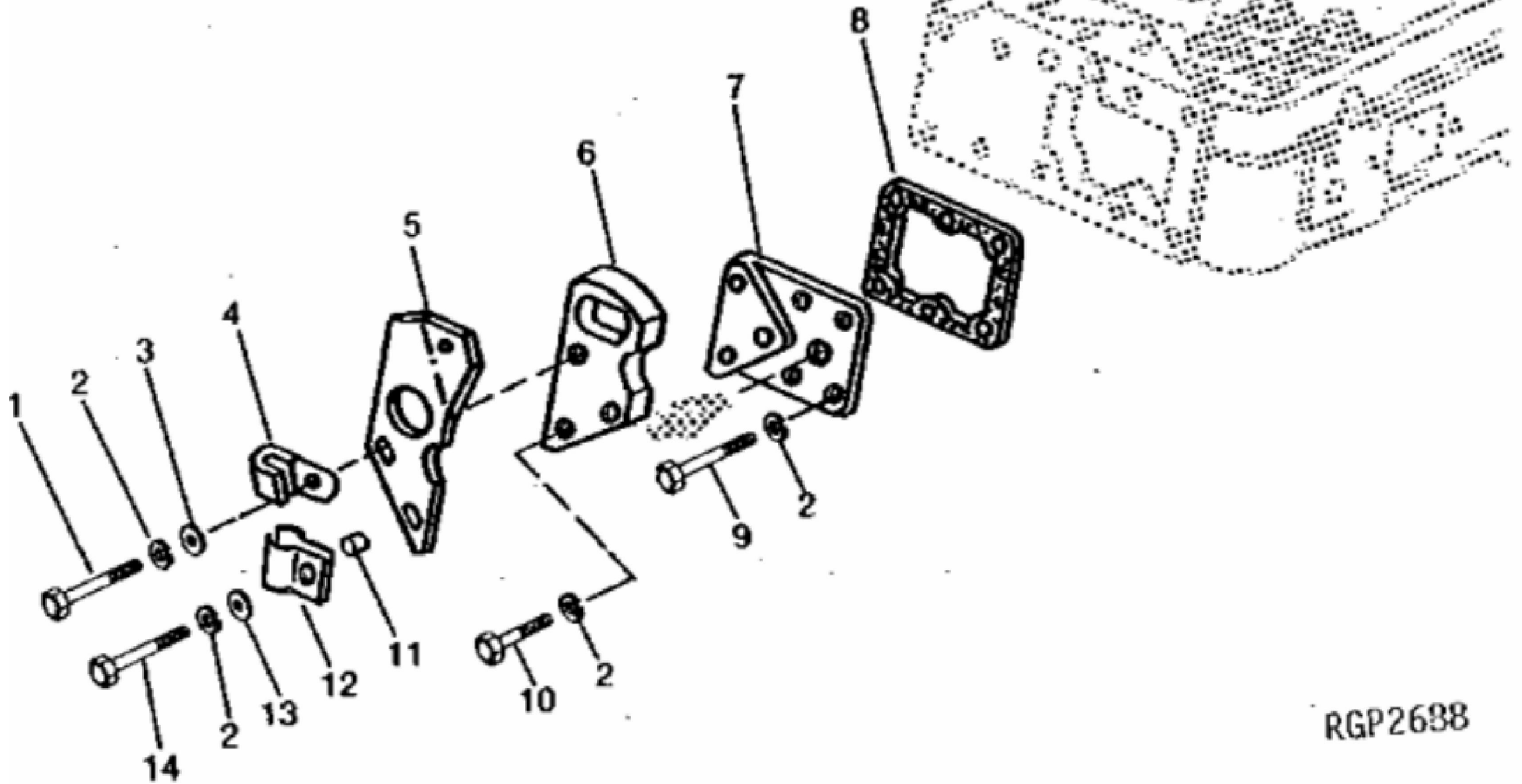

RGP2638

<https://www.ebooklibonline.com>

Hello dear friend!

Thank you very much for reading.

Enter the link into your browser.

The full manual is available for immediate download.

<https://www.ebooklibonline.com>