

KEY	PART NO.	PART NAME	QTY	REMARKS	
1	R524499	GASKET	1		
2	19M7775	SCREW	2	M6 X 16	
3	R515555	DEFLECTOR	1		
4	R543296	HOSE	1		
5	TY22462	CLAMP	1		
6	RE561710	VALVE COVER	1	MARKED R540192	
7	RE542918	VALVE	1	USE WITH RE561710	
8	R123575	O-RING	5		
9	R521390	SCREW	5		
10	H23125	PLUG	5		
11	R529614	VALVE COVER	1	ORDER RE561710	
12	R532038	VALVE	1	ORDER RE542918; USE WITH R529614	

**<https://www.ebooklibonline.com>**

Hello dear friend!

Thank you very much for reading.

Enter the link into your browser.

The full manual is available for immediate download.

**<https://www.ebooklibonline.com>**

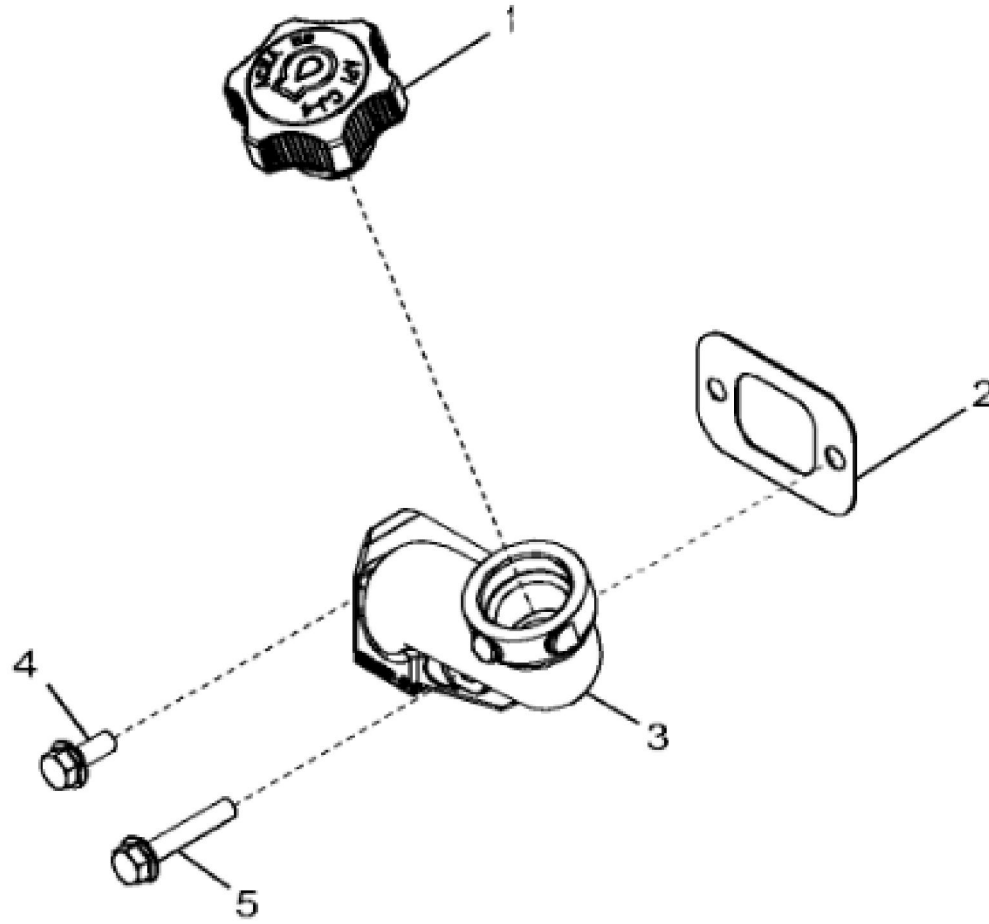

1251\_RE548009\_PCD

John Deere > Construction And Forestry >BACKHOE, LOADER >315SL - BACKHOE, LOADER >315SL Backhoe Loader (Engine 4045HT082,4045HT096)(PIN: 1T0315SL\_\_F273920- ) >04A ENGINE  
4045HT096-DZ104580 >0400A ENGINE 4045HT096-DZ104580 4045HT096 >ST569457 - 1251 OIL FILLER NECK

KEY	PART NO.	PART NAME	QTY	REMARKS	
1	RE545569	FILLER CAP	1		
2	R136495	GASKET	1		
3	R532001	FILLER NECK	1		
4	RE67238	SCREW	1		
5	RE67239	SCREW	1		

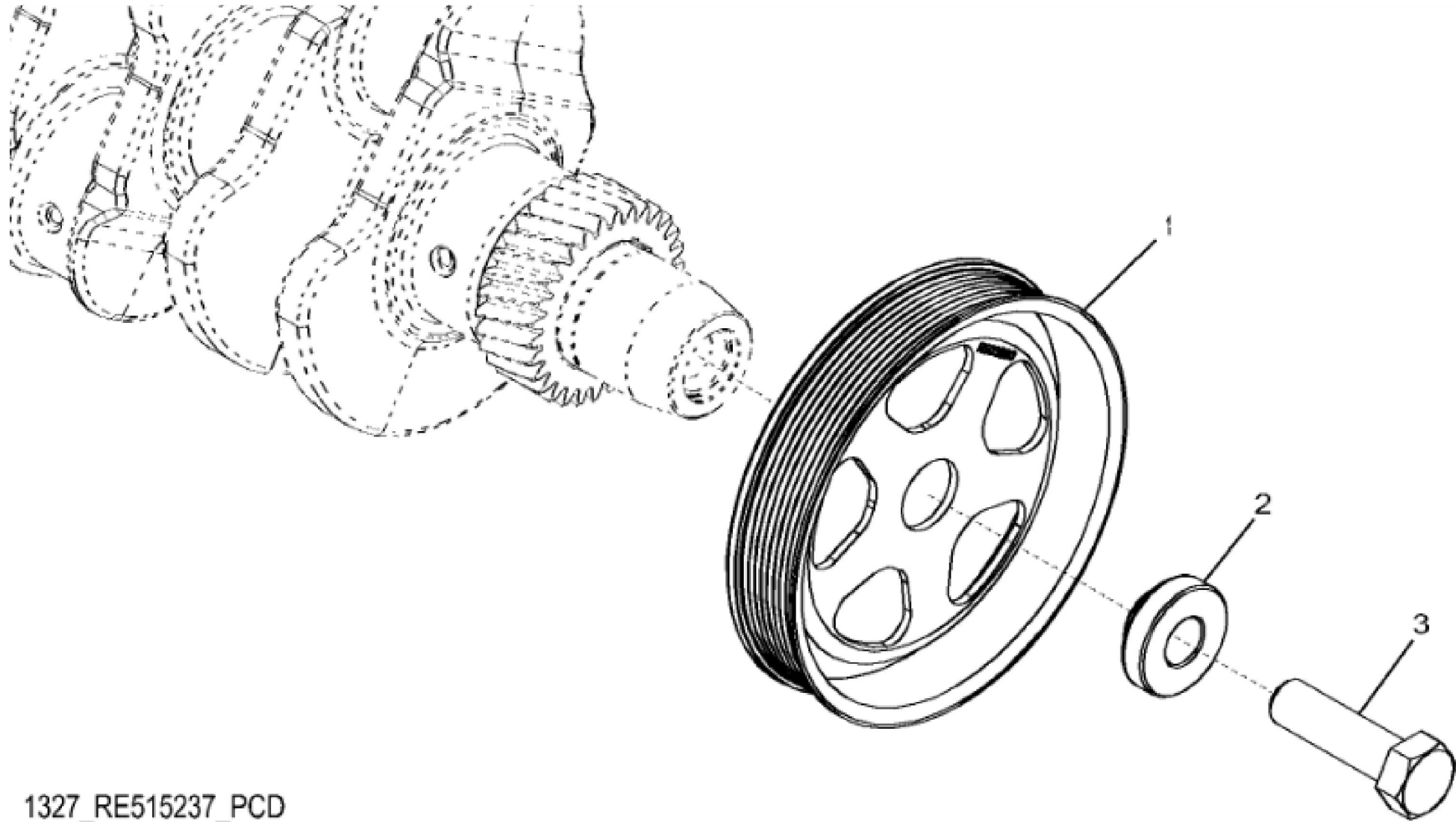

1327\_RE515237\_PCD



**Suggest:**

**For more complete manuals. Please go to the home page.**

**<https://www.ebooklibonline.com>**

**If the above button click is invalid. Please download this document first, and then click the above link to download the complete manual.**

**Thank you so much for reading**

John Deere > Construction And Forestry >BACKHOE, LOADER >315SL - BACKHOE, LOADER >315SL Backhoe Loader (Engine 4045HT082,4045HT096)(PIN: 1T0315SL\_ \_F273920- ) >04A ENGINE

4045HT096-DZ104580 >0400A ENGINE 4045HT096-DZ104580 4045HT096 >ST308624 - 1327 CRANKSHAFT PULLEY

KEY	PART NO.	PART NAME	QTY	REMARKS	
1	R503880	PULLEY	1	OD = 188 mm	
2	R515040	BUSHING	1	OD = 50 mm	
3	R516648	CAP SCREW	1	M20 X 70	

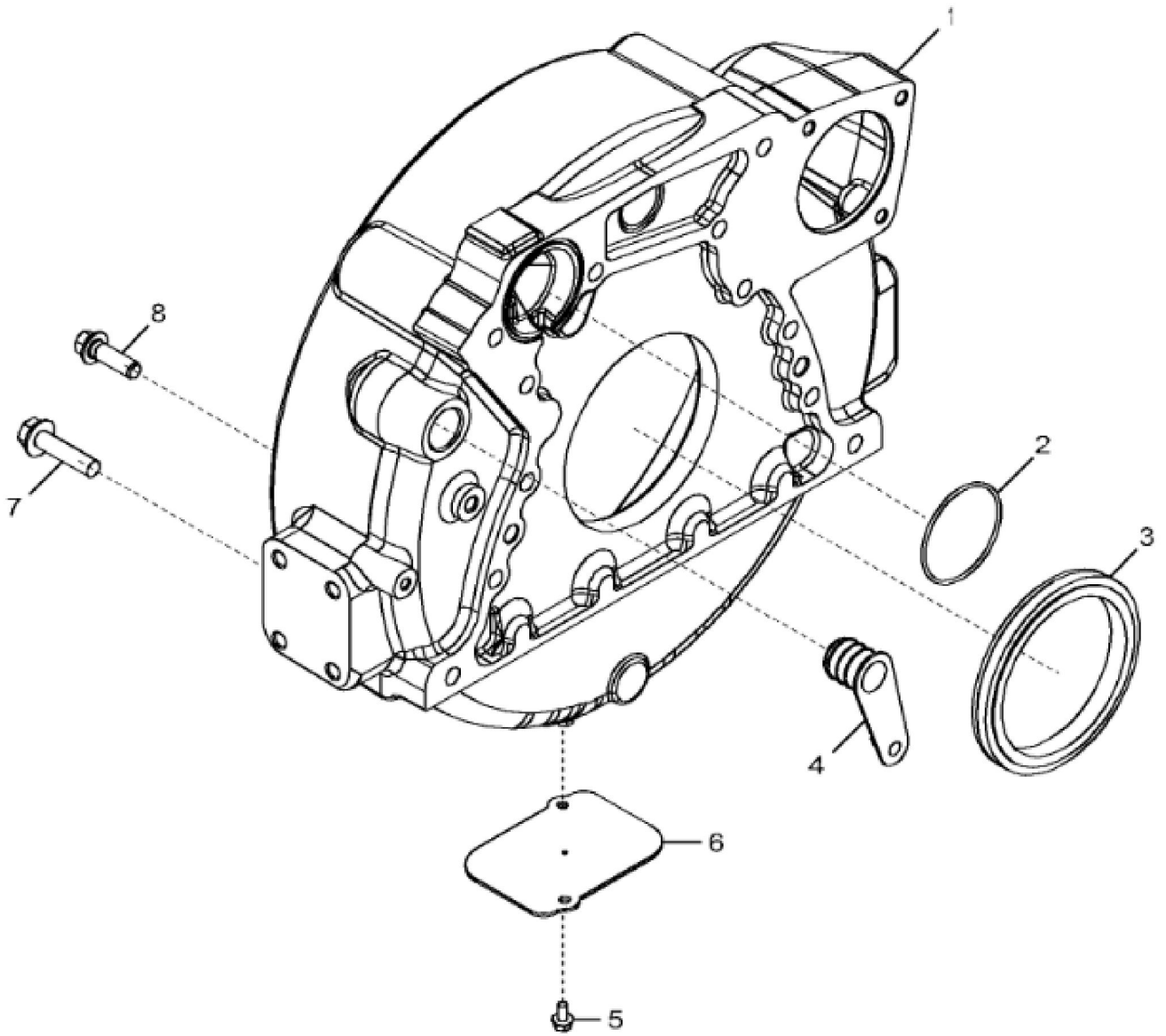

**<https://www.ebooklibonline.com>**

Hello dear friend!

Thank you very much for reading.

Enter the link into your browser.

The full manual is available for immediate download.

**<https://www.ebooklibonline.com>**