

TP45520

John Deere > Construction And Forestry >BACKHOE, LOADER >315CH - BACKHOE, LOADER >315CH Sideshift Backhoe Loader >5 ENGINE AUXILIARY SYSTEM 5 >COOLING SYSTEMS 0510 >0510-3 - RADIATOR FAN SHROUD [01D23]

KEY	PART NO.	PART NAME	QTY	REMARKS
1	24M7139	WASHER	6	6.400 X 18 X 1.600 MM
2	37H116	SCREW	6	
3	SHROUD	1	(T128745 NO LONGER AVAILABLE) (SUB FOR T100329 AND T113048) (SUB T151641) (ALSO ORDER AT167782 OR M61266)
3	T151641	SHROUD	1	
4	AT114230	GUARD	1	RIGHT
4	AT114229	GUARD	1	LEFT (NOT ILLUSTRATED)
5	19M7867	SCREW	2	M8 X 25
6	19M7867	SCREW	4	M8 X 25
7	24M7238	WASHER	2	8.700 X 17 X 2 MM, (USE WITH T128745)
8	19M7881	SCREW	2	H.S. 10.9M 8 X 20, (USE WITH T128745)
9	B32585	STRAP	1	(USE WITH T128745)
10	M61266	PLUG	1	(USE WITH T151641)

<https://www.ebooklibonline.com>

Hello dear friend!

Thank you very much for reading.

Enter the link into your browser.

The full manual is available for immediate download.

<https://www.ebooklibonline.com>

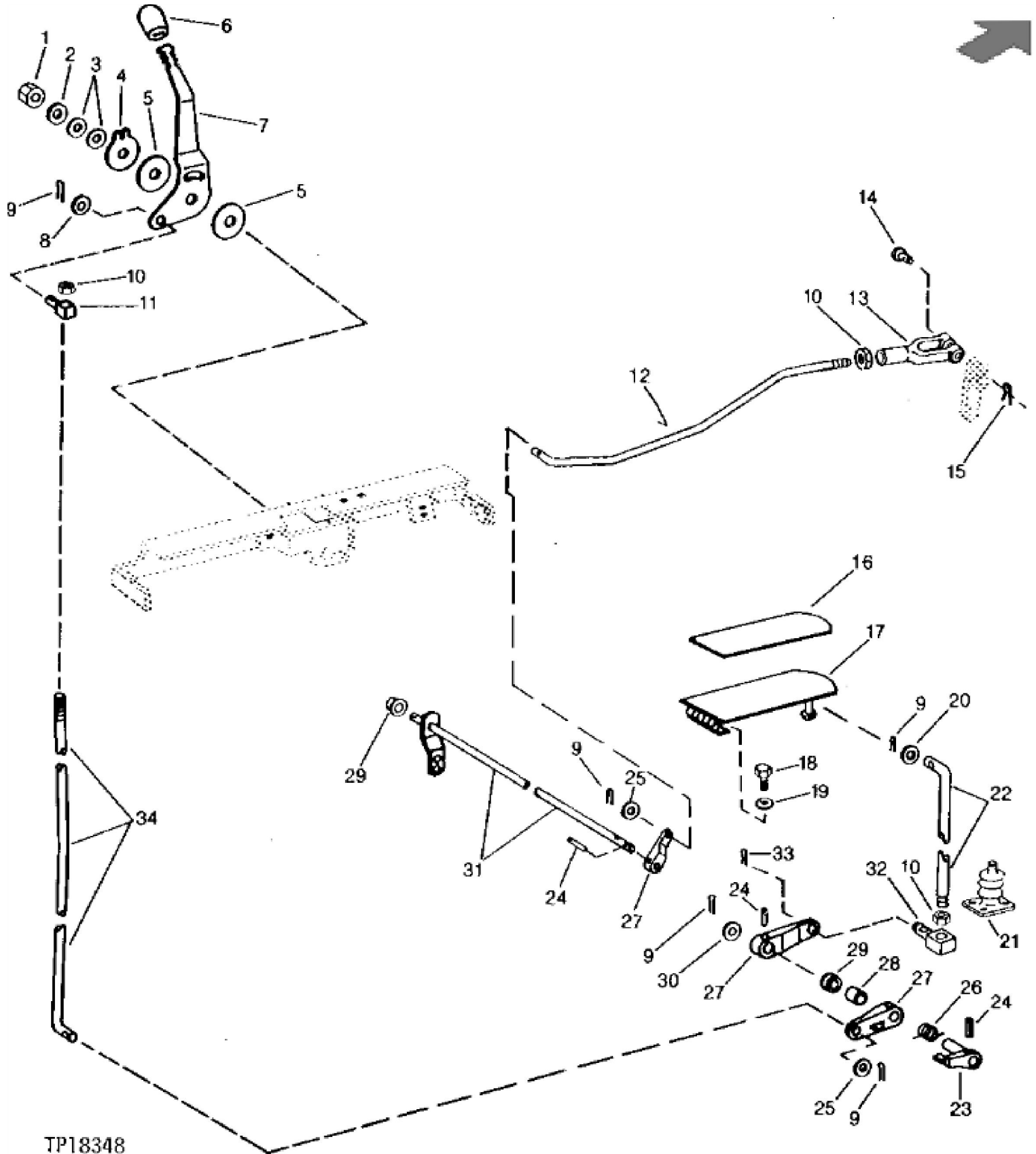

TP18348

KEY	PART NO.	PART NAME	QTY	REMARKS
1	T11234	LOCK NUT	1	
2	24H1304	WASHER	1	13/32" X 23/32" X 0.120"
3	12M7059	DISK SPRING	2	10.200 X 20 X 0.800 MM
4	R33976	PLATE	1	
5	R39985	WASHER	2	(SUB FOR T113234)
6	T68101	KNOB	1	
7	T68442	LEVER	1	
8	24H1286	WASHER	1	9/32" X 1/2" X 1/16"
9	11M7077	COTTER PIN	5	1.600 X 25 MM
10	14H649	NUT	3	1/4"
11	T35887	SWIVEL	1	
12	T113403	ROD	1	
13	M3742T	YOKE	1	
14	R662R	PIN FASTENER	1	
15	11M7082	COTTER PIN	1	2.500 X 25 MM
16	T68445	MAT	1	
17	AT75316	PEDAL	1	
18	19M7774	SCREW	2	M6 X 12
19	24M7088	WASHER	AR	6.600 X 12 X 1.600 MM, (NO LONGER REQUIRED)
20	24H1286	WASHER	1	9/32" X 1/2" X 1/16"
21	AT75317	BOOT	1	
21	19M7774	SCREW	3	M6 X 12
22	T79459	HOOK BOLT	1	
23	T22150	ARM	1	
24	34H264	SPRING PIN	3	5/32" X 7/8"
25	24H1286	WASHER	2	9/32" X 1/2" X 1/16"
26	T77165	SPRING	1	
27	T22240	ARM	3	
28	28H1521	SPACER	1	0.493" X 0.675" X 9/16"
29	T22241	GROMMET	2	
30	24H1305	WASHER	1	13/32" X 13/16" X 0.065"
31	AT114061	SHAFT	1	
32	T35887	SWIVEL	1	
33	11M7079	COTTER PIN	1	2.500 X 12 MM



Suggest:

For more complete manuals. Please go to the home page.

<https://www.ebooklibonline.com>

If the above button click is invalid. Please download this document first, and then click the above link to download the complete manual.

Thank you so much for reading

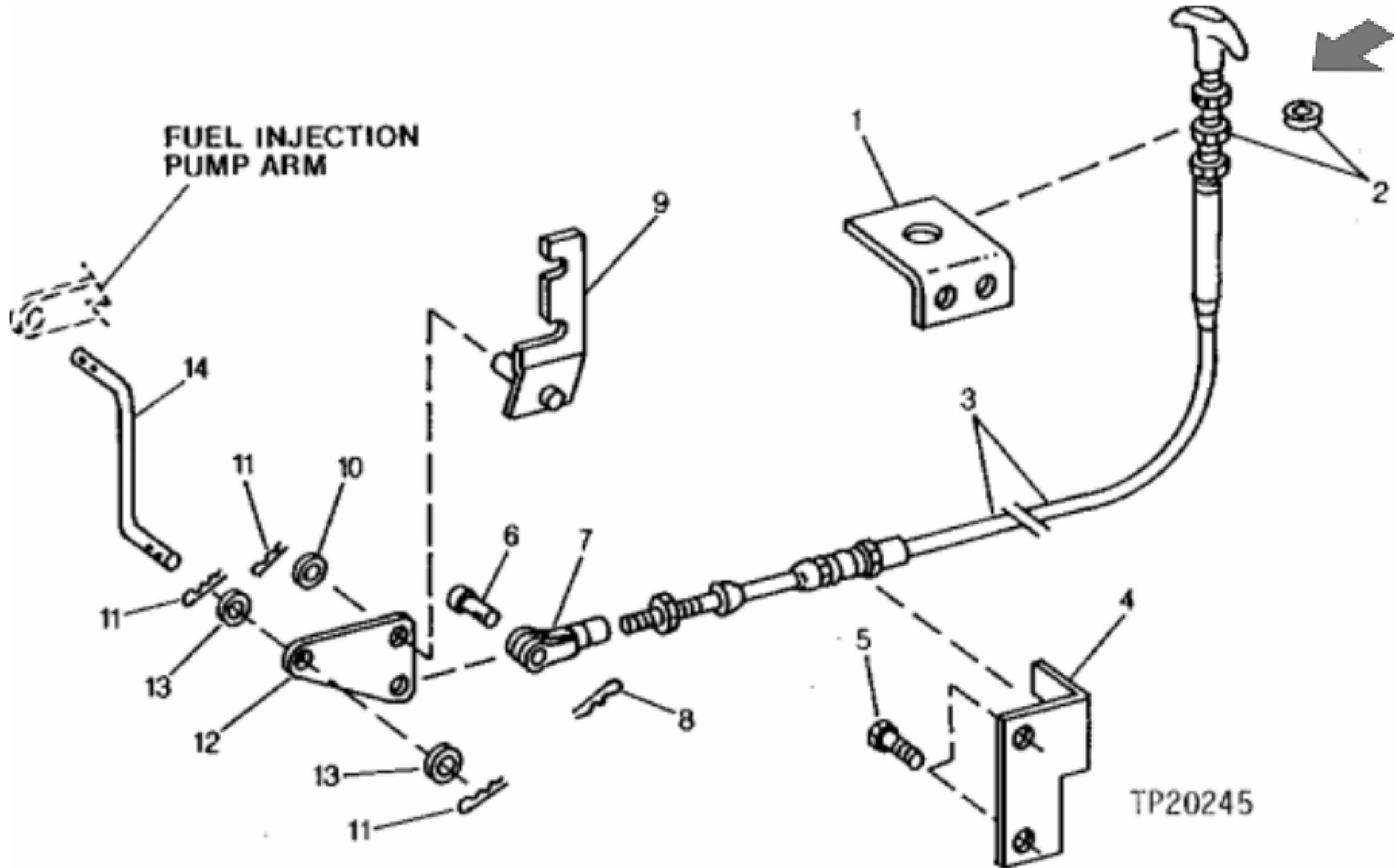

John Deere > Construction And Forestry >BACKHOE, LOADER >315CH - BACKHOE, LOADER >315CH Sideshift Backhoe Loader >5 ENGINE AUXILIARY SYSTEM 5 >SPEED CONTROLS 0515 >0515-4 - ENGINE STOP CABLE [01E01]

KEY	PART NO.	PART NAME	QTY	REMARKS
1	T113198	ANGLE	1	
2	24H1191	WASHER	2	1/2" X 1-1/2" X 0.105"
3	AT114509	PUSH PULL CABLE	1	
4	T113646	BRACKET	1	
5	19H1895	CAP SCREW	2	1/2" X 3/4"
6	L985T	PIN FASTENER	1	
7	L987T	YOKE	1	
8	11M7077	COTTER PIN	1	1.600 X 25 MM
9	AT114249	BRACKET	1	
10	24H1286	WASHER	1	9/32" X 1/2" X 1/16"
11	11M7076	COTTER PIN	5	1.600 X 12 MM
12	T113645	PLATE	1	
13	24M7138	WASHER	4	5.300 X 15 X 1.200 MM
14	T113647	PIN FASTENER	1	

<https://www.ebooklibonline.com>

Hello dear friend!

Thank you very much for reading.

Enter the link into your browser.

The full manual is available for immediate download.

<https://www.ebooklibonline.com>