

MP12542

KEY	PART NO.	PART NAME	QTY	Serial No.	REMARKS
1	HE134-0673	GEAR	1		(*)
2	HE104-0170	SCREW	1		
3	12H293	LOCK WASHER	1		7/16"
4	HE526-0262	WASHER	1		
5	HE134-2467	FLYWHEEL	1	____-120169	
5	HE134-2462	FLYWHEEL	1	120170-____	
6	HE104-0032	GEAR	1		
7	HE517-0082	BALL	1		
8	HE104-1698	CRANKSHAFT	1		(SUB FOR HE104-1312 OR HE104-0865)
9	KEY	1		(CUT FROM H64376)
10	26H70	SHAFT KEY	1		1/8" X 1/2"
11	26H11	SHAFT KEY	1		3/16" X 5/8", (SUB FOR HE515-0227)
11	HE515-0284	KEY	1		(USE WITH 110-3421-01 SHORTBLOCK)
12	HE104-0043	WASHER	1		
13	U11030	SNAP RING	1		(SUB FOR HE518-0014)
14	HE104-1694	SPACER	1		(USE WITH 110-3421-01 SHORTBLOCK)

<https://www.ebooklibonline.com>

Hello dear friend!

Thank you very much for reading.

Enter the link into your browser.

The full manual is available for immediate download.

<https://www.ebooklibonline.com>

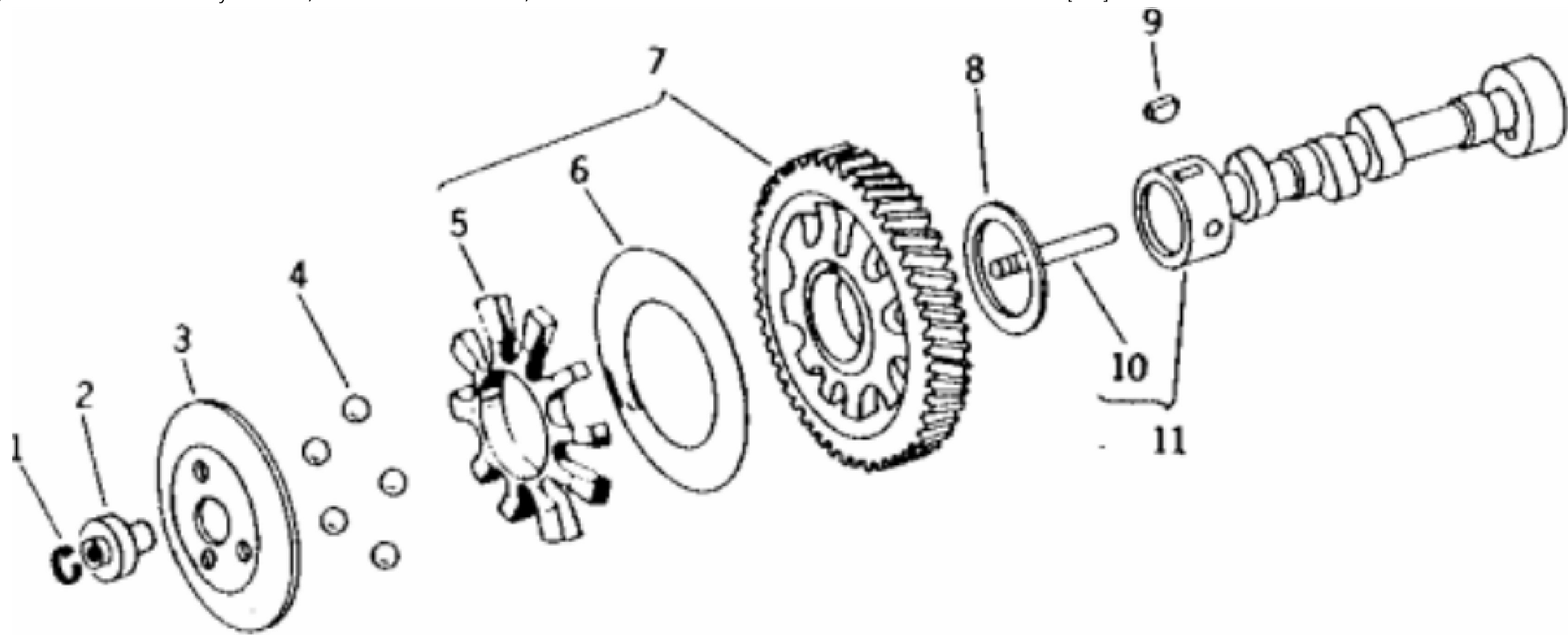

311624F

KEY	PART NO.	PART NAME	QTY	REMARKS	
1	HE150-0078	SNAP RING	1	(A)	
2	HE150-1519	HUB	1	(A)	
3	HE150-1520	DISK	1	(A)	
4	HE510-0015	BALL	5	(A)	
5	SPACER	1	(SUB HE105-0332)	
6	PLATE	1	(SUB HE105-0332)	
7	HE105-0332	GEAR	1	(SUB FOR HE105-0030)	
8	HE105-0541	THRUST WASHER	1	(SUB FOR HE105-0004)	
9	26H70	SHAFT KEY	1	1/8" X 1/2", (SUB FOR PT7929)	
10	PIN	1	(SUB HE105-0382)	
11	HE105-0594	CAMSHAFT	1	(SUB FOR HE105-0487, HE105-0379 AND HE105-0382)	
..	AM118304	KIT	1	GOVERNOR (INCL. PARTS MARKED "A")	



Suggest:

For more complete manuals. Please go to the home page.

<https://www.ebooklibonline.com>

If the above button click is invalid. Please download this document first, and then click the above link to download the complete manual.

Thank you so much for reading

KEY	PART NO.	PART NAME	QTY	Serial No. or Year	REMARKS
1	HE113-0166	PISTON RING	2	____-120169	(SUB HE113-0312)
1	HE11541	PISTON RING KIT	2	____-120169	(*) (0.13MM) .005" OVERSIZE
1	HE11542	PISTON RING	2	____-120169	(0.25MM) .010" OVERSIZE
1	HE11543	PISTON RING KIT	2	____-120169	(0.51MM) .020" OVERSIZE
1	HE11544	PISTON RING KIT	2	____-120169	(0.76MM) .030" OVERSIZE
1	HE11545	PISTON RING KIT	2	____-120169	(1.02MM) .040" OVERSIZE
1	HE113-0203	PISTON RING	2	120170-____	STD. (SUB HE113-0296)
1	AM38617	PISTON RING	2	120170-____	(0.13MM) .005" OVERSIZE
1	AM38618	PISTON RING	2	120170-____	(0.25MM) .010" OVERSIZE, (SUB AM117835)
1	AM117577	PISTON RING	2	120170-____	(0.51MM) .020" OVERSIZE, (SUB FOR AM38619)
1	AM38620	PISTON RING	2	120170-____	(0.76MM) .030" OVERSIZE
1	AM38621	PISTON RING	2	120170-____	(1.02MM) .040" OVERSIZE
2	HE805-0010	CAP SCREW	4		
3	CAP	1		(SUB HE114-0203)
4	HE114-0188	BEARING	4		(HALF)
4	HE10260	KIT	4		(0.05MM) .002" UNDERSIZE, (SUB HE10263) BEARING
4	HE10261	KIT	4		(0.25MM) .010" UNDERSIZE, (SUB HE10263) BEARING
4	HE10262	KIT	4		(0.51MM) .020" UNDERSIZE, (SUB HE10263) BEARING
4	HE10263	KIT	4		(0.76MM) .030" UNDERSIZE, BEARING
5	HE114-0036	BUSHING	1		
6	HE114-0203	CONNECTING ROD	2		
7	HE112-0112	KINGPIN	2	____-120169	(*)
7	HE10249	PIN FASTENER	2	____-1979	(*) (0.05MM) .002" OVERSIZE
7	HE112-0069	PIN	2	120170-____	
8	HE518-0294	SNAP RING	4		
9	HE112-0141	PISTON	2	____-120169	(SUB HE112-0180) PISTON AND PIN
9	HE10567	PISTON	2	____-120169	(*) (0.13MM) .005" OVERSIZE, PISTON AND PIN
9	HE10568	PISTON	2	____-120169	(0.25MM) .010" OVERSIZE, PISTON AND PIN
9	HE10569	PISTON	2	____-120169	(0.51MM) .020" OVERSIZE, PISTON AND PIN
9	HE10570	PISTON	2	____-120169	(0.76MM) .030" OVERSIZE, PISTON AND PIN
9	HE10571	PISTON	2	____-120169	(*) (1.02MM) .040" OVERSIZE, PISTON AND PIN
9	HE112-0185	PISTON	2	120170-____	STD., (SUB FOR HE112-0158)
9	HE112-0227	PISTON	2		STD., PISTON AND PIN, USE WITH SHORTBLOCK STAMPED 110-3421-01

KEY	PART NO.	PART NAME	QTY	Serial No. or Year	REMARKS
9	AM104200	PISTON	2	120170-_____	(0.13MM) .005" OVERSIZE, (SUB FOR AM38612) (SUB AM117575)
9	AM101155	PISTON	2	120170-_____	(0.25MM) .010" OVERSIZE, (SUB FOR AM38613) (SUB AM117834 AND AM117835)
9	AM101156	PISTON	2	120170-_____	(0.51MM) .020" OVERSIZE, (SUB FOR AM38614) (SUB AM118417)
9	AM101157	PISTON	2	120170-_____	(0.76MM) .030" OVERSIZE, (SUB FOR AM38615) (SUB AM104201)
9	AM104201	PISTON	2	120170-_____	(1.02MM) .040" OVERSIZE, (SUB FOR AM38616 OR AM101157)

<https://www.ebooklibonline.com>

Hello dear friend!

Thank you very much for reading.

Enter the link into your browser.

The full manual is available for immediate download.

<https://www.ebooklibonline.com>