

RGP4147

John Deere > Construction And Forestry > EXCAVATOR > 992ELC - EXCAVATOR > 992ELC Excavator > 04 ENGINE 6101AT010 > 0407 OILING SYSTEM 6101AT010 6101AT010 > ST309671 - OIL BYPASS VALVE HOUSING AND FILTER

KEY	PART NO.	PART NAME	QTY	REMARKS
1	R51936	SEALING WASHER	2	
2	RE50830	OIL LINE	1	
3	R67364	ELBOW FITTING	2	
4	15H511	PIPE BUSHING	1	1/8"
5	RE47161	ORIFICE	1	
6	15H638	PIPE PLUG	1	1/8"
7	A4925R	ADAPTER FITTING	1	
8	R112061	BASE	1	
9	R47153	O-RING	4	
10	R82500	OIL LINE	2	
11	R86875	FITTING PLUG	2	
12	U17409	O-RING	2	
13	R26151	SPRING	2	
14	R49464	VALVE	2	
15	R49484	GASKET	1	
16	19H2553	CAP SCREW	2	3/8" X 2-5/8"
17	19H1731	CAP SCREW	1	3/8" X 1"
18	15H690	PIPE PLUG	2	3/4"
19	19H1854	CAP SCREW	1	3/8" X 3-3/4"
20	19H2855	CAP SCREW	1	3/8" X 3-1/4"
21	15H686	PIPE PLUG	1	1"
22	19H2733	CAP SCREW	3	3/8" X 2-3/8"
23	R82491	HOUSING	1	
24	R49485	GASKET	1	
25	19H1801	CAP SCREW	1	3/8" X 2"
26	T20173	STUD	1	
27	E55662	FLANGE NUT	1	
28	RE44647	OIL FILTER	1	(MARKED RE44647)(FULL-FLOW AND BY-PASS)

<https://www.ebooklibonline.com>

Hello dear friend!

Thank you very much for reading.

Enter the link into your browser.

The full manual is available for immediate download.

<https://www.ebooklibonline.com>

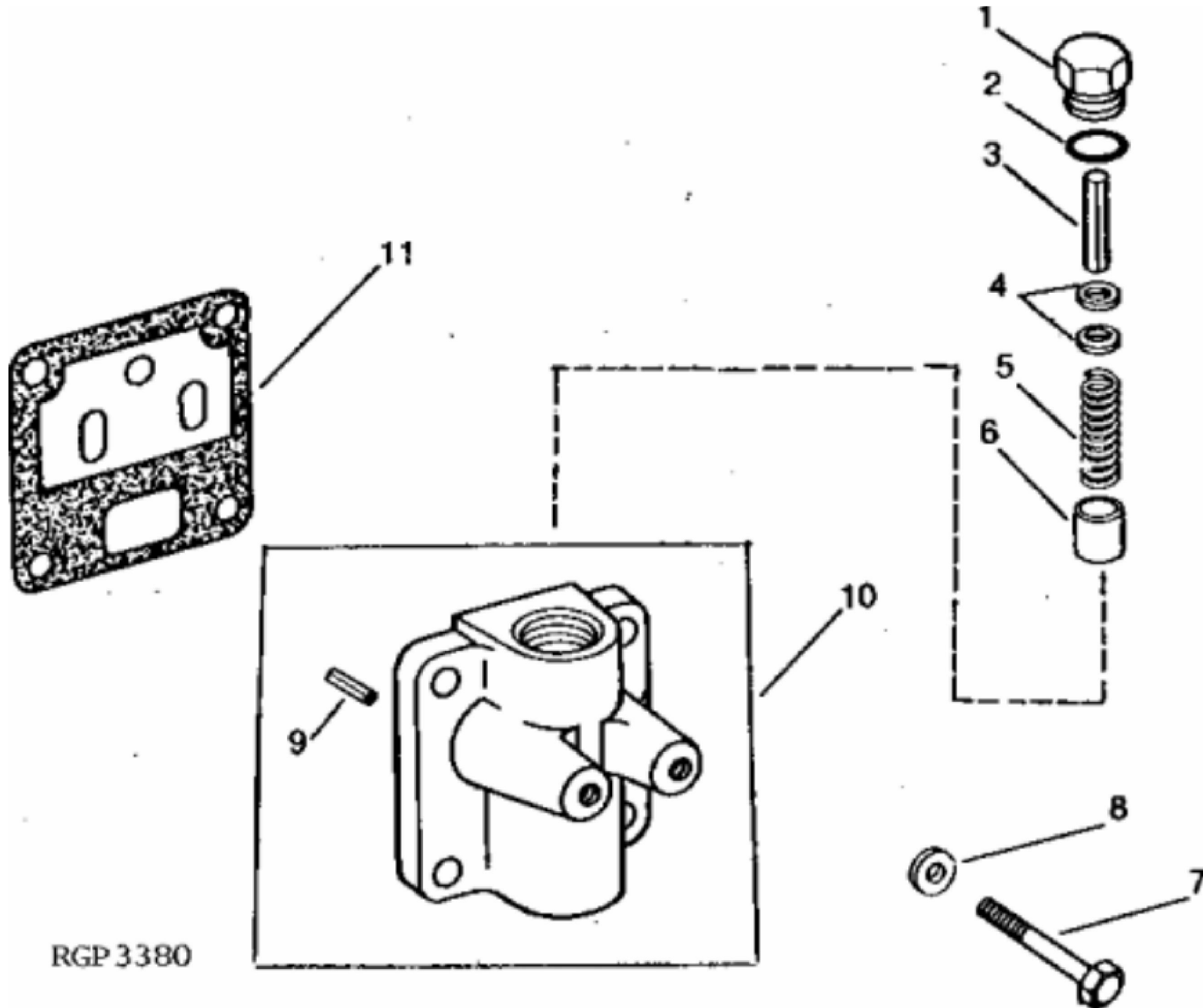

RGP 3380

John Deere > Construction And Forestry > EXCAVATOR > 992ELC - EXCAVATOR > 992ELC Excavator > 04 ENGINE 6101AT010 > 0407 OILING SYSTEM 6101AT010 6101AT010 > ST309672 - OIL PRESSURE REGULATING VALVE HOUSING

KEY	PART NO.	PART NAME	QTY	REMARKS
1	R49465	DRAIN PLUG	1	3/4" X 1/4" X 55/64"
2	U17409	O-RING	1	
3	34H386	SPRING PIN	1	1/4" X 2"
4	24H1286	WASHER	3	9/32" X 1/2" X 1/16"
5	R82141	SPRING	1	
6	R56021	VALVE	1	
7	19H1731	CAP SCREW	4	3/8" X 1"
8	12H304	LOCK WASHER	NA	3/8"
9	34H387	SPRING PIN	1	3/16" X 3/4"
10	RE20889	HOUSING	1	(MARKED R82149)
11	R114332	GASKET	1	



Suggest:

For more complete manuals. Please go to the home page.

<https://www.ebooklibonline.com>

If the above button click is invalid. Please download this document first, and then click the above link to download the complete manual.

Thank you so much for reading

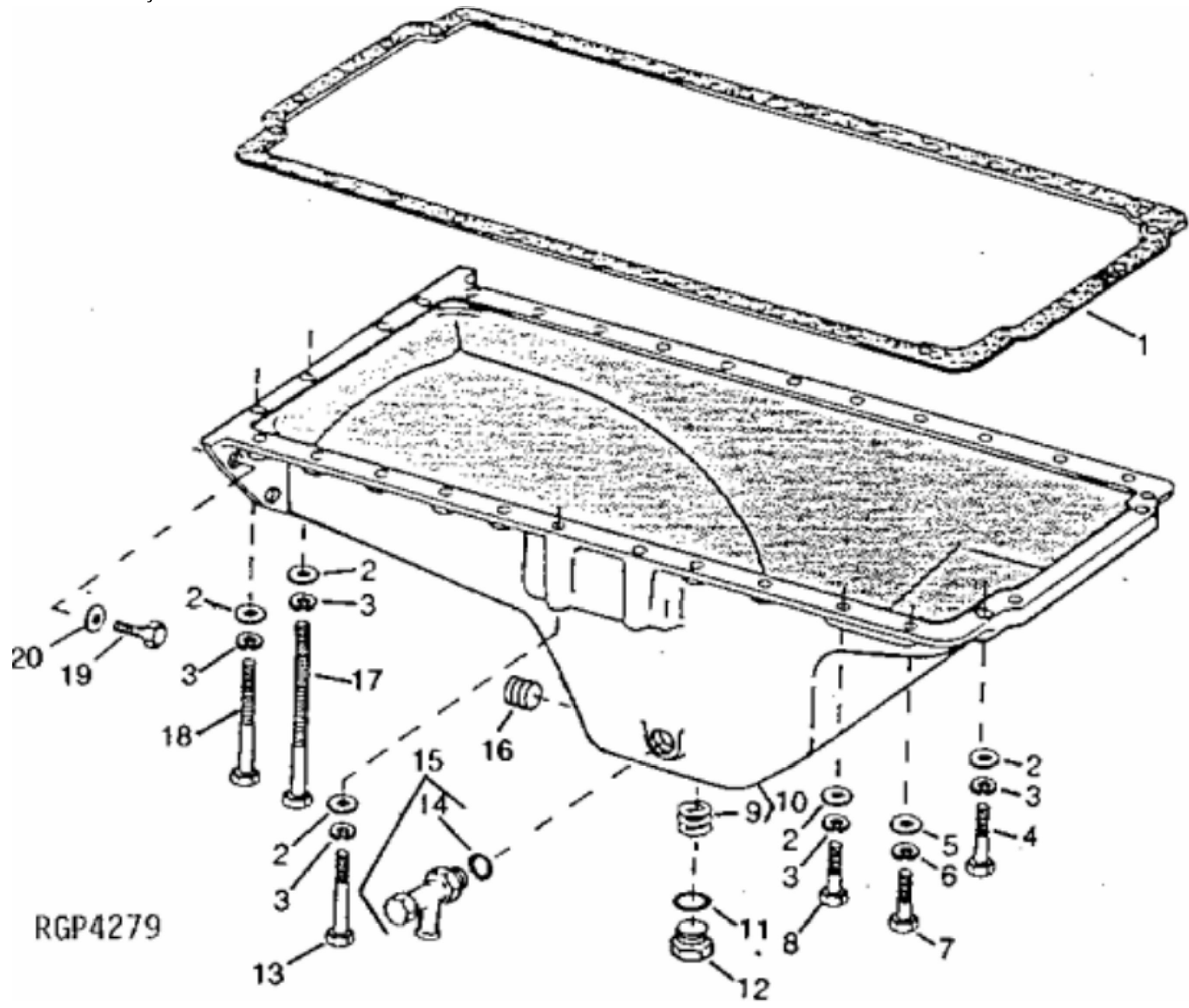

RGP4279

KEY	PART NO.	PART NAME	QTY	REMARKS
1	RE509291	GASKET	1	(THICK), (SUB FOR R64828)
2	24H1305	WASHER	28	13/32" X 13/16" X 0.065"
3	12H304	LOCK WASHER	28	3/8"
4	19H3485	CAP SCREW	2	3/8" X 2"
5	24H1756	WASHER	2	1/2" X 1" X 0.060"
6	12H301	LOCK WASHER	2	1/2"
7	19H2473	CAP SCREW	2	1/2" X 1-3/4"
8	19H3267	CAP SCREW	20	3/8" X 1-5/8"
9	R79480	INSERT	NA	(OIL PAN INSERT)
10	R108983	OIL PAN	1	
11	A4827R	WASHER	1	
12	R26727	DRAIN PLUG	1	
13	19H3565	CAP SCREW	2	3/8" X 6-1/8", (GR G)
14	R26906	O-RING	1	
15	AT152180	DRAIN VALVE	1	
16	RE57836	PIPE PLUG	1	12.700 mm, (SUB FOR 15H624)
17	R121240	CAP SCREW	2	
18	19H3563	CAP SCREW	2	3/8" X 6-5/8"
19	19H2431	CAP SCREW	6	3/4" X 2-1/4", (SUB FOR 19H1782)
20	R78019	WASHER	6	

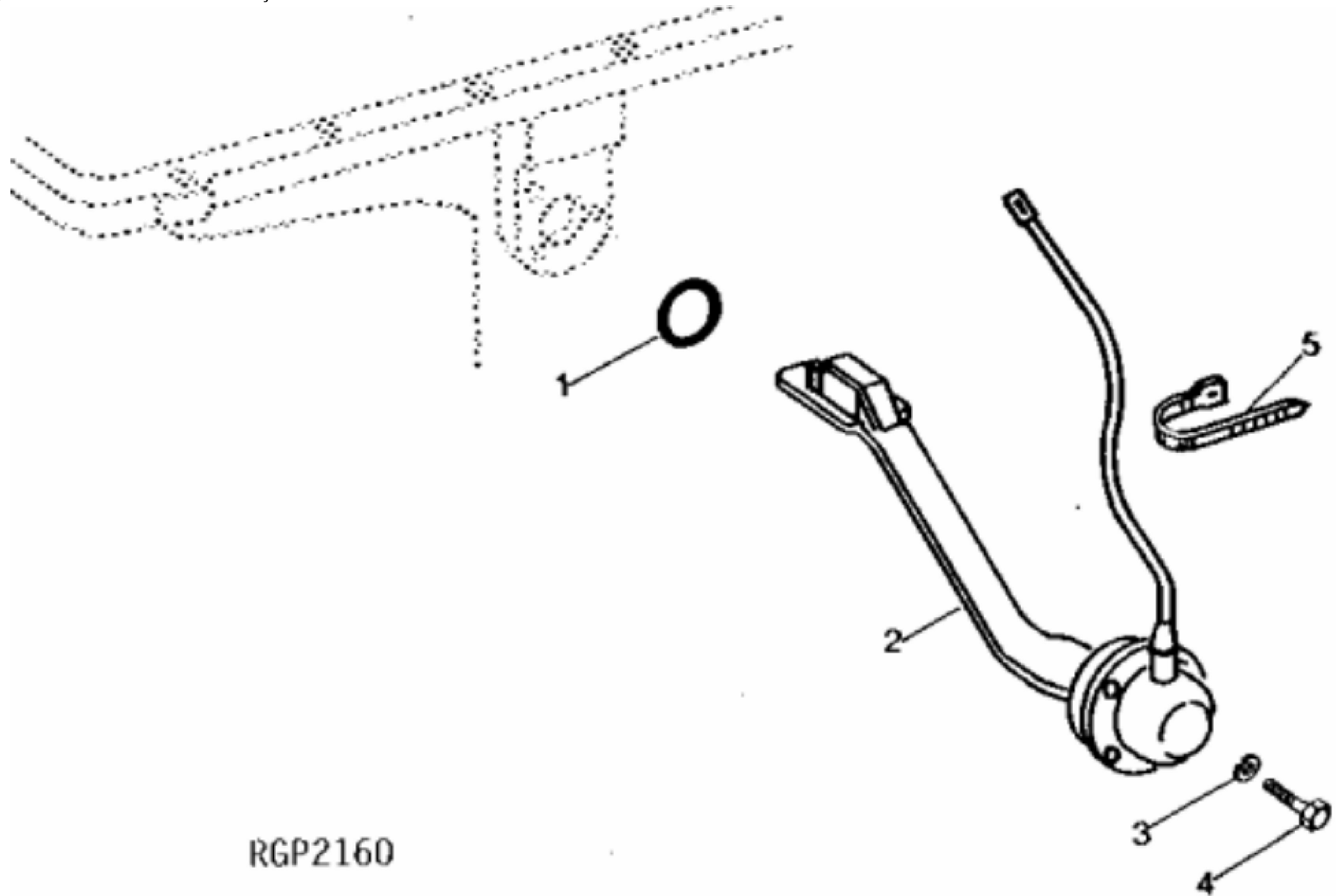

RGP2160

<https://www.ebooklibonline.com>

Hello dear friend!

Thank you very much for reading.

Enter the link into your browser.

The full manual is available for immediate download.

<https://www.ebooklibonline.com>