

KEY	PART NO.	PART NAME	QTY	REMARKS
1	R62938	GEAR	1	
2	T21242	WASHER	1	
3	14H826	NUT	1	1/2"
4	14H785	NUT	1	5/16"
5	22H1040	SET SCREW	1	5/16" X 1-1/4"
6	R71732	O-RING	2	
7	R104628	SCREW	3	(COVER TO OIL PUMP HSG)
7	R104628	SCREW	2	
8	RE44118	OIL PUMP	1	(MARKED R62946) (SUB RE60622)
8	SE501063	OIL PUMP REMAN	1	(REMANUFACTURED FOR RE44118)
9	R57696	WASHER	4	
10	19H2549	CAP SCREW	2	3/8" X 1-7/8"
11	19H3219	CAP SCREW	2	3/8" X 1-3/8"
12	R69418	GASKET	1	
13	R62948	ELBOW FITTING	1	
14	R62947	TUBE	1	
15	19H3483	CAP SCREW	3	3/8" X 1-1/8"
16	R100569	GASKET	1	
17	RE60622	OIL PUMP	1	(MARKED R62946) (SUB FOR AR94479, AR96193, AR99344 OR RE44118, APPL)
18	M72490	WASHER	3	
..	R62930	BUSHING	2	(USE W/OIL PUMP)

<https://www.ebooklibonline.com>

Hello dear friend!

Thank you very much for reading.

Enter the link into your browser.

The full manual is available for immediate download.

<https://www.ebooklibonline.com>

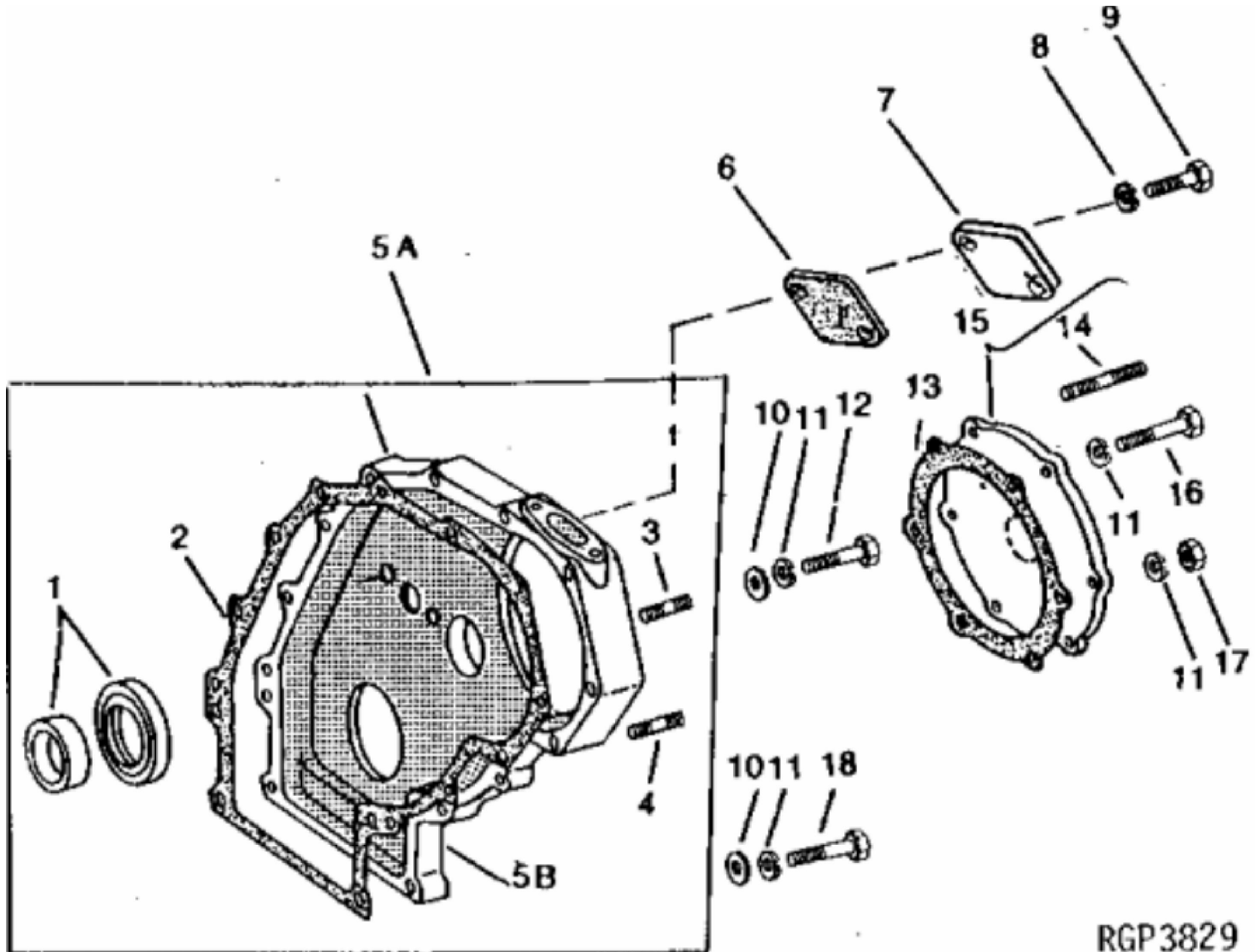

RGP3829

John Deere > Construction And Forestry >CRAWLER LOADER >855 - CRAWLER LOADER >855 Crawler Loader >4 ENGINE 4 >CAMSHAFT AND VALVE ACTUATING MEANS 0402 >0402-6 - TIMING GEAR COVER [02B20]

KEY	PART NO.	PART NAME	QTY	Engine Serial No.	REMARKS
1	AR49025	SEAL	1		
2	R49483	GASKET	1		
3	R699R	STUD	1	____-048709	(SUB T20173 AND R51604, APPL)
3	T20173	STUD	1	048710-____	
4	R699R	STUD	1		(SUB FOR R32042 OR T20173, APPL USE WITH NO BELT TIGHTENER)
4	R47105	STUD	1		(SUB FOR R32042, APPL USE WITH BELT TIGHTENER)
5A	AR67511	COVER	1	____-030335	(A) (MARKED R48835) (ALSO ORDER (2) R51604, R67770, R67769, (2) 12H302, (2) 19H1948)
5A	AR88415	COVER	1	030336-045017	(A) (MARKED R67342) (ALSO ORDER (2) R51604, APPL)
5A	RE10830	COVER	1	045018-048709	(A) (MARKED R77301) (ALSO ORDER (2) R51604, APPL)
5A	RE14134	COVER	1		(A)
5B	R77301	COVER	1	048710-061336	(SUB FOR RE14134) (SUB R110147, APPL)
5B	R110147	COVER	1	061337-____	
6	R67770	GASKET	1	030336-____	
7	R67769	COVER	1	030336-____	
8	12H302	LOCK WASHER	2	030336-____	1/4"
9	19H1948	CAP SCREW	2	030336-____	1/4" X 3/4"
10	24H1305	WASHER	9	061337-____	
11	12H304	LOCK WASHER	15		3/8", (NOT REQUIRED WITH E55662)
12	19H1801	CAP SCREW	5		3/8" X 2"
13	R35349	GASKET	1		
14	R114130	STUD	1	____-048709	(SUB D2420R AND R51604) (SUB FOR R55396, APPL)
14	D2420R	STUD	1	048710-____	
15	AR67538	COVER	1	____-048709	(MARKED R55506) (SUB RE42820 AND R51604, APPL)
15	RE14129	COVER	1	048710-059783	(MARKED R55506) (SUB RE42820)
15	RE42820	COVER	1	059784-____	(MARKED R105579)
16	19H1733	CAP SCREW	4		3/8" X 2-1/2"
17	E55662	FLANGE NUT	1		(NO LONGER REQUIRED)
18	19H1800	CAP SCREW	4		3/8" X 1-1/2"



Suggest:

For more complete manuals. Please go to the home page.

<https://www.ebooklibonline.com>

If the above button click is invalid. Please download this document first, and then click the above link to download the complete manual.

Thank you so much for reading

John Deere > Construction And Forestry >CRAWLER LOADER >855 - CRAWLER LOADER >855 Crawler Loader >4 ENGINE 4 >CONNECTING RODS AND PISTONS 0403 >0403-2 - PISTON, RINGS, LINERS, AND CONNECTING RODS [02B22]

KEY	PART NO.	PART NAME	QTY	Engine Serial No.	REMARKS
1	R60197	BUSHING	6	____-034178	(USE WITH R66925 OR R57484)
2	R66453	CAP SCREW	12		(SUB FOR R48316)
3	R48317	SLEEVE	12		
4	AR86985	CONNECTING ROD	6	____-034178	(MARKED R66925 OR R57484) (SUB FOR AR69037) (SUB SE500499 AND RE20291)
5	N51168	SNAP RING	12		
6	R64451	PISTON PIN	6		
7	AR82355	PISTON RING KIT	6		
8	AR72351	O-RING KIT	6		
9	AR84089	PISTON-LINER KIT	6	____-034178	(A) (MARKED AR69038) (SUB FOR AR77558) (USE WITH BLOCK MARKED R57424 OR R66925)
9	RE20291	PISTON-LINER KIT	6	034179-049059	(A) (MARKED AR85997 OR RE20275) (SUB FOR AR89630)
9	RE20288	PISTON-LINER KIT	6	049060-____	(B) (MARKED AR85997 OR RE20275) (SUB FOR RE13847) (SUB RE40476)
9	RE40476	PISTON-LINER KIT	6		(B) (MARKED RE40433 OR RE42231)
10	R81276	SHIM	AR		0.05 MM
10	R81277	SHIM	AR		0.10 MM
11	AR101271	BEARING	AR		STD (PKG.(2) R74671 OR (2) R75148) (SUB FOR AR101271)
11	AR104129	BEARING	AR		0.05 MM (.002") US, (PKG.(2) R60198, (2) R75166 OR (2) R76649) (SUB FOR AR73026)
11	AR104130	BEARING	AR		0.25 MM (.010") US, (PKG.(2) R60199, (2) R75167 OR (2) R76650) (SUB FOR AR73027)
11	AR104131	BEARING	AR		0.50 MM (.020") US, (PKG.(2) R60200, (2) R75158 OR (2) R76651) (SUB FOR AR73028)
11	AR104132	BEARING	AR		0.75 MM (.030") US, (PKG.(2) R60201, (2) R75165 OR (2) R76652) (SUB FOR AR73029)
12	R69045	BUSHING	6		(USE WITH R63959) (MARKED R63960)
13	AR79366	CONNECTING ROD	6	034179-____	(MARKED R63959) (SUB SE500499)
13	SE500499	CONNECTING ROD REMAN	6		(REMANUFACTURED)

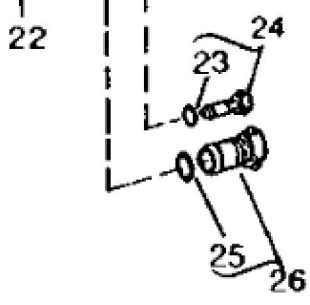
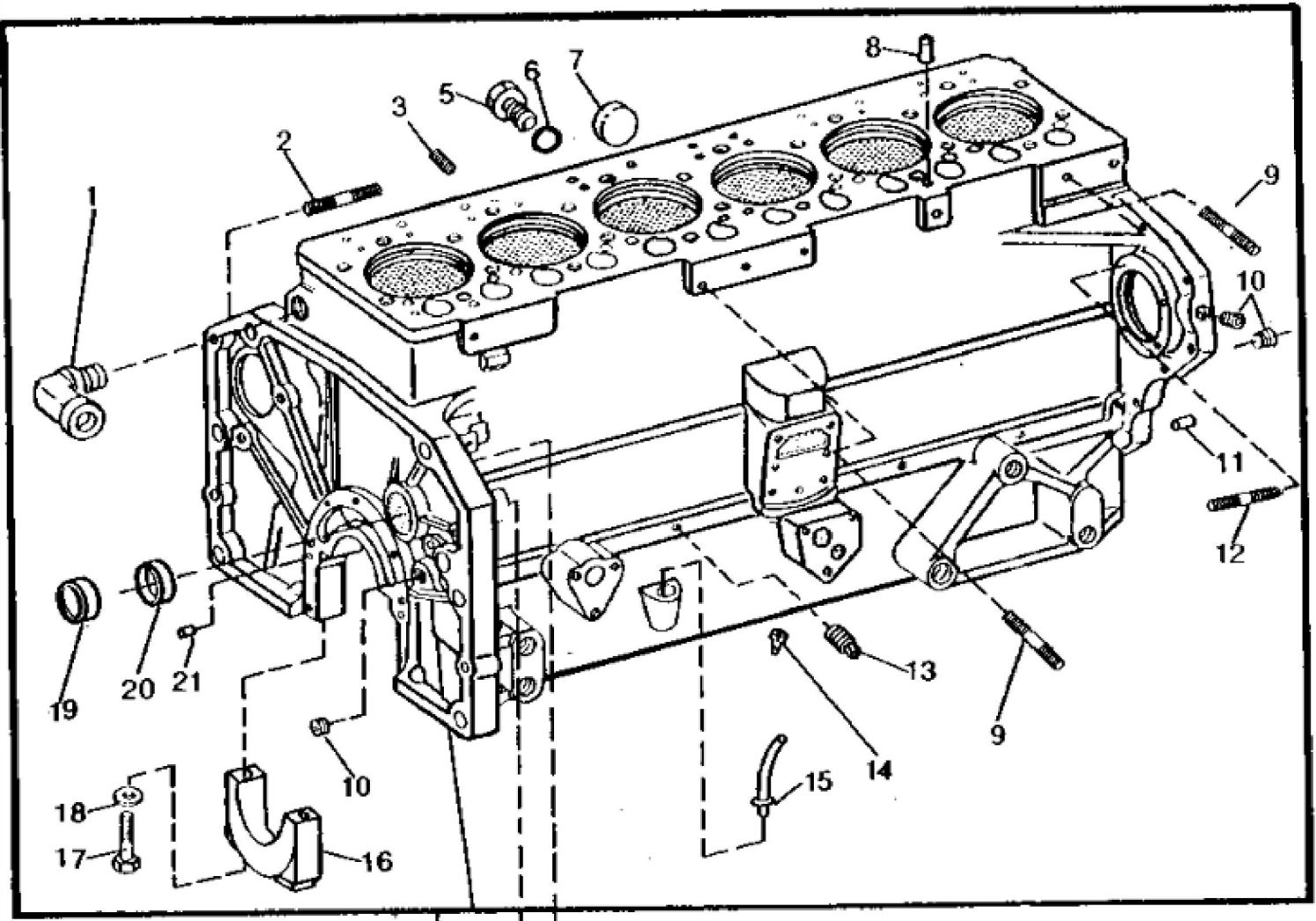

RGP2092

<https://www.ebooklibonline.com>

Hello dear friend!

Thank you very much for reading.

Enter the link into your browser.

The full manual is available for immediate download.

<https://www.ebooklibonline.com>