

RGP2116

KEY	PART NO.	PART NAME	QTY	Engine Serial No.	REMARKS
1	15H665	PIPE PLUG	1	____-280000	3/4", (SUB FOR AR72318)
1	15H562	PIPE PLUG	1	280001-____	1", (SUB FOR AR78522)
2	15H690	PIPE PLUG	2		3/4", (SUB FOR AR78522)
3	AR80294	PLUG	1	280001-____	(WITHOUT ENGINE COOLANT HEATER) (SUB FOR R47092)
4	AR44382	DRAIN VALVE	1		3/8"
4	AT13740	DRAIN VALVE	1		1/4"
5	R32042	STUD	1		
6	R106859	STUD	1		(SUB FOR F3646R OR R26622, THIS APPLICATION)
7	R42340	BUSHING	2		
8	15H666	PIPE PLUG	1		
9	R45740	PLUG	1		
10	R1612R	DOWEL PIN	2		
11	RE57836	PIPE PLUG	2		1/2", (SUB FOR AR72319 OR 15H624)
12	K3083R	STUD	2		7/16" X 1-3/4"
13	F1743R	DOWEL PIN	2		
14	R48755	STUD	2		5/16" X 1-1/2", (SUB FOR R26934)
15	R104592	PIPE PLUG	4		(SUB FOR R21630, THIS APPLICATION)
16	R104592	PIPE PLUG	1		
17	R43621	ORIFICE	6		
18	15H666	PIPE PLUG	1		3/8"
19	R41070	TUBE	1		
20	30H25	PLUG	1	280001-____	2"
21	.....	DOWEL PIN	1		(NO LONGER REQUIRED)
22	T15539	BOLT	14		
23	R57158	BEARING CAP	6		(MAIN)
23	R57159	BEARING CAP	1		(MAIN THRUST)
24	R26115	PLUG	1		
25	R46903	BUSHING	4		
26	R43634	DOWEL PIN	1		
27	AR43496	CYLINDER BLOCK	1	____-257844	(MARKED R43310) (NO LONGER AVAILABLE)
27	AR50297	CYLINDER BLOCK	1	257845-280000	(MARKED R45980) (NO LONGER AVAILABLE)
27	AR52061	CYLINDER BLOCK	1	280001-____	(MARKED R47020)
28	R520530	GASKET	1		(SUB FOR R43442 OR R45968)

**<https://www.ebooklibonline.com>**

Hello dear friend!

Thank you very much for reading.

Enter the link into your browser.

The full manual is available for immediate download.

**<https://www.ebooklibonline.com>**

KEY	PART NO.	PART NAME	QTY	Engine Serial No.	REMARKS
29	R43441	COVER	1		
30	12H304	LOCK WASHER	5		3/8"
31	19H2284	CAP SCREW	5		3/8" X 7/8"
32	AR52563	DIPSTICK	1	____-280000	(SUB FOR AR52624)
32	AR53998	DIPSTICK	1	280001-____	(SUB FOR AR53997)
..	RE13551	SHORT BLOCK ASSEMBLY	1	____-280000	(A) (MARKED R43310 OR R45890) (SUB FOR AR50292 OR AR46061) (SUB SE500609, THIS APPLICATION)
..	SE500609	SHORT BLOCK ASSEMBLY	1	280001-____	(REMANUFACTURED FOR RE13551)(1-800-537-3626)
..	RE13552	SHORT BLOCK ASSEMBLY	1	280001-____	(A) (MARKED R47020) (SUB FOR AR53092) (SUB SE500608, THIS APPLICATION)
..	SE500608	SHORT BLOCK ASSEMBLY	1	280001-____	(SUB FOR RE13552, RE53476 OR RE70108) (REMANUFACTURED FOR RE13552)(1-800-537-3626)



**Suggest:**

**For more complete manuals. Please go to the home page.**

**<https://www.ebooklibonline.com>**

**If the above button click is invalid. Please download this document first, and then click the above link to download the complete manual.**

**Thank you so much for reading**

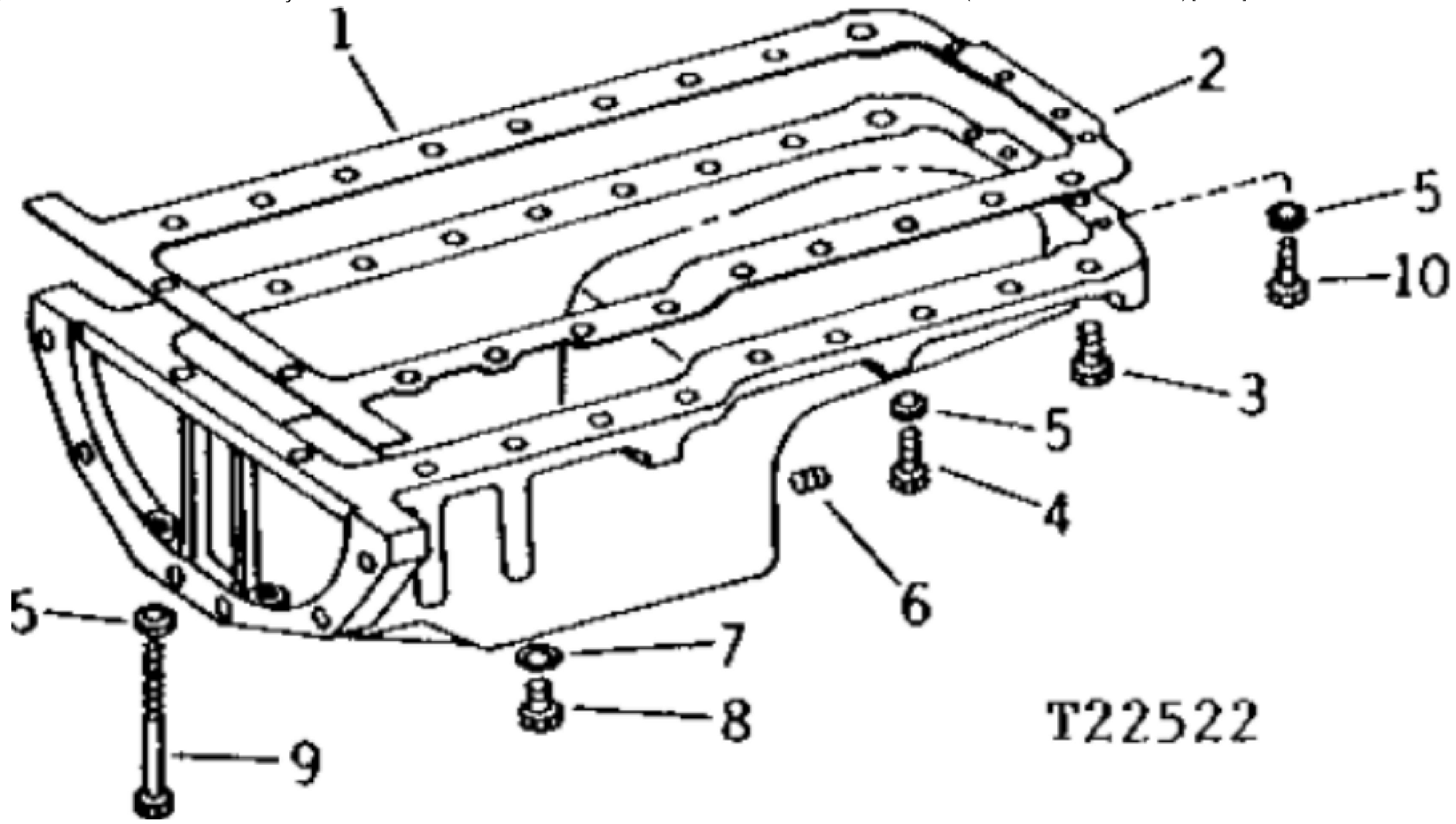

T22522

KEY	PART NO.	PART NAME	QTY	REMARKS	
1	R520583	GASKET	1	(SUB FOR R42424 OR R71918)	
2	R53013	OIL PAN	1	(SUB AR94560) (SUB FOR R43119)	
3	R27693	SCREW	2		
4	19H3483	CAP SCREW	16	3/8" X 1-1/8"	
4	19H2104	CAP SCREW	2	3/8" X 5"	
5	12H304	LOCK WASHER	22	3/8"	
6	15H665	PIPE PLUG	1	3/4"	
7	A4827R	WASHER	1		
8	R26727	DRAIN PLUG	1		
9	19H3041	CAP SCREW	2	3/8" X 6"	
10	19H1765	CAP SCREW	2	3/8" X 1-3/4"	

**<https://www.ebooklibonline.com>**

Hello dear friend!

Thank you very much for reading.

Enter the link into your browser.

The full manual is available for immediate download.

**<https://www.ebooklibonline.com>**