

- 1 - Bolt
- 2 - Washer
- 3 - Washer

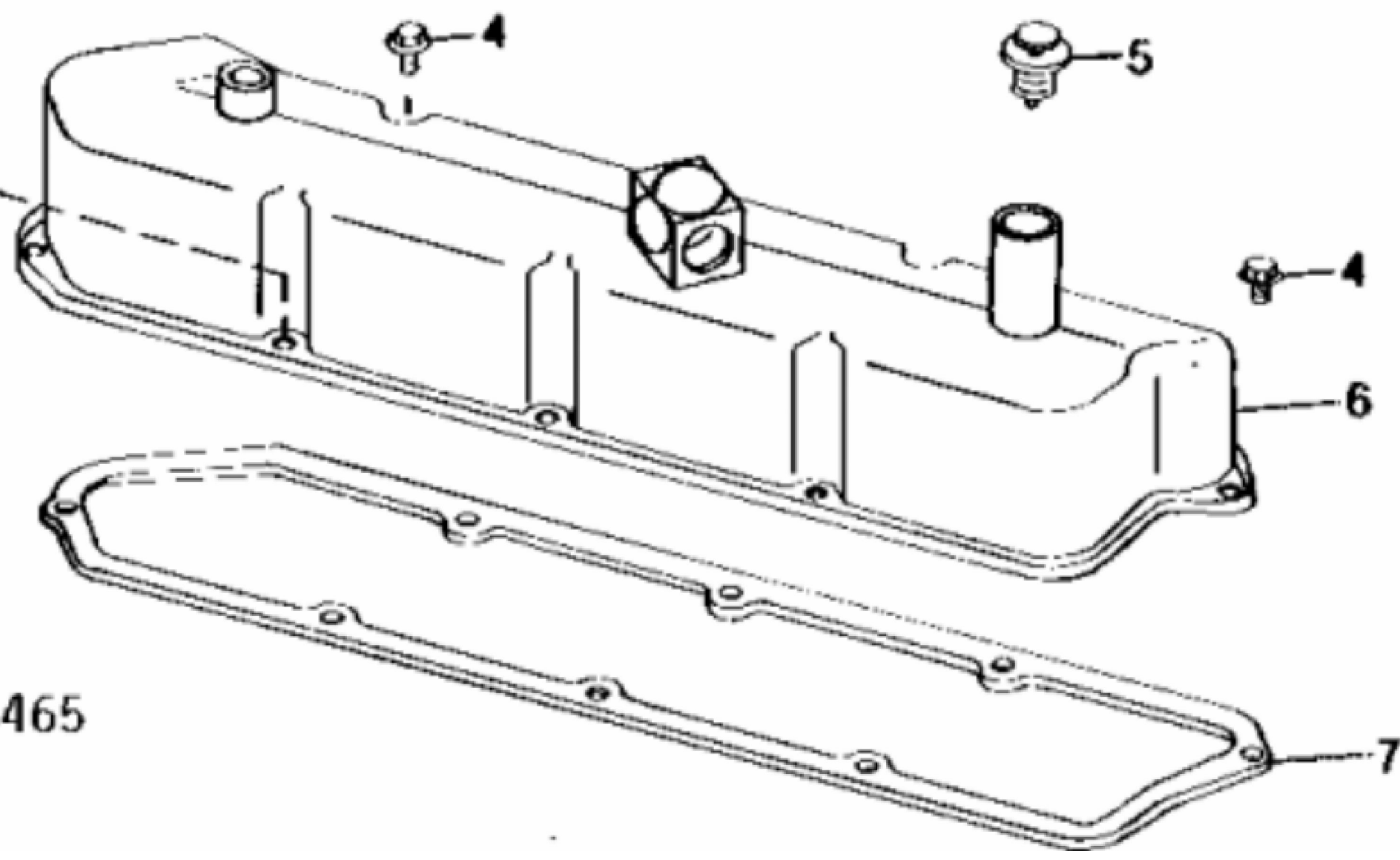

TP16465

KEY	PART NO.	PART NAME	QTY	REMARKS	
1	19H2036	CAP SCREW	1	1/4" X 7/8"	
2	12H302	LOCK WASHER	1	1/4"	
3	R64764	WASHER	1		
4	AR103811	SCREW WITH WASHER	8	(SUB FOR AR100124)	
5	AR65864	FILLER CAP	1		
6	AR71130	VALVE COVER	1		
7	AR100596	GASKET	1		

<https://www.ebooklibonline.com>

Hello dear friend!

Thank you very much for reading.

Enter the link into your browser.

The full manual is available for immediate download.

<https://www.ebooklibonline.com>

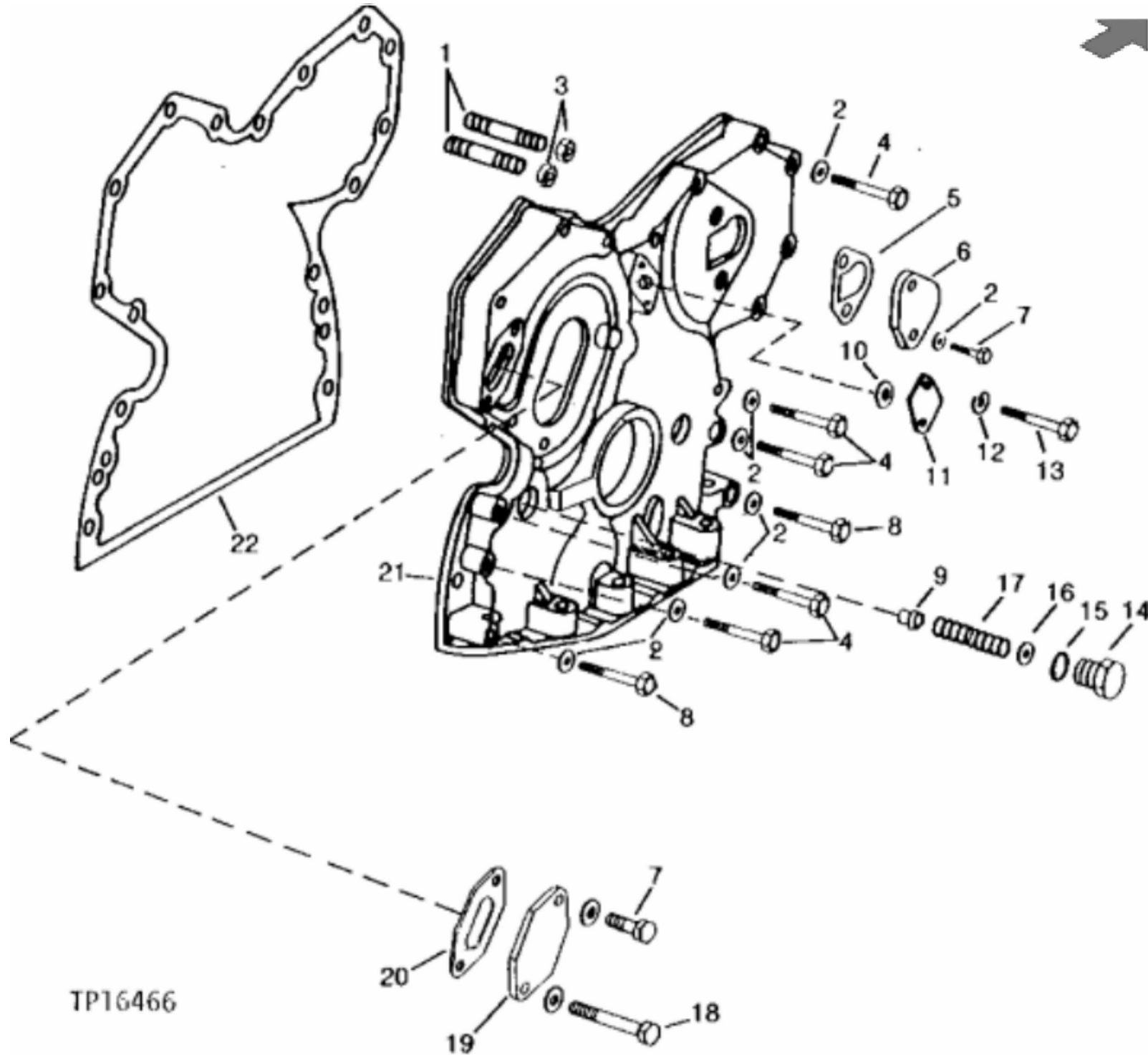

TP16466

KEY	PART NO.	PART NAME	QTY	REMARKS
1	R122226	STUD	2	(SUB FOR R122226)
2	24H1304	WASHER	AR	13/32" X 23/32" X 0.120"
3	14H812	NUT	2	3/8"
4	19H2549	CAP SCREW	10	3/8" X 1-7/8", (USE WITH AR91662)
4	19H2549	CAP SCREW	4	(USE WITH RE30685)
5	R78366	GASKET	1	
6	R126041	COVER	1	(SUB FOR T20362)
7	19H2284	CAP SCREW	1	3/8" X 7/8", (USE WITH AR91662)
7	19H3385	CAP SCREW	5	1/2" X 1-1/8", (USE WITH RE30685)
7	19H1648	CAP SCREW	1	
7	R124277	CAP SCREW	3	(SUB FOR R122618, THIS APPLICATION) (USE WITH T23260 OR R126041)
8	19H3031	CAP SCREW	2	3/8" X 2-1/2", (USE WITH AR91662)
8	19H1733	CAP SCREW	1	3/8" X 2-1/2", (USE WITH AR91662)
8	19H3181	CAP SCREW	1	3/8" X 2", (USE WITH RE30685)
9	R51516	VALVE	1	OIL PRESSURE RELIEF
10	R47154	O-RING	1	
11	R67769	COVER	1	
12	12H302	LOCK WASHER	2	1/4"
13	19H1948	CAP SCREW	2	1/4" X 3/4"
14	T27657	FITTING PLUG	1	
15	A4827R	WASHER	1	
16	24H1290	WASHER	1	21/64" X 3/4" X 0.035"
17	T27658	SPRING	1	
18	19H1726	CAP SCREW	1	3/8" X 2-1/4"
19	T23260	COVER	1	
20	T20336	GASKET	1	
21	RE30685	COVER	1	(SUB FOR AR91662) (ALSO ORDER (5) 19H2545, (4) 19H2549 AND 19H3181)
22	T20155	GASKET	1	



Suggest:

For more complete manuals. Please go to the home page.

<https://www.ebooklibonline.com>

If the above button click is invalid. Please download this document first, and then click the above link to download the complete manual.

Thank you so much for reading

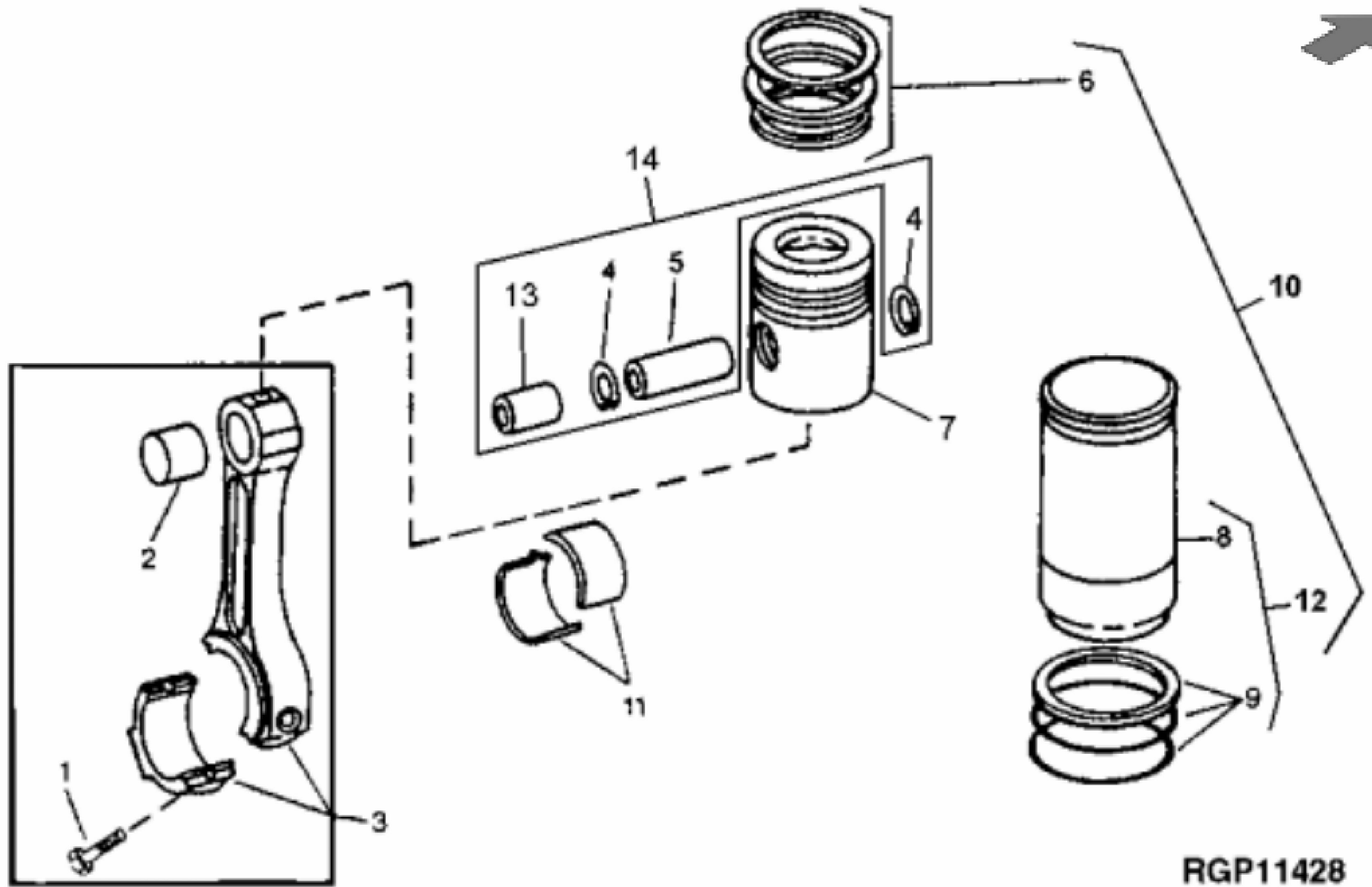

RGP11428

John Deere > Construction And Forestry > EXCAVATOR > 595 - EXCAVATOR > 595 Excavator > 4 ENGINE 4 > CONNECTING RODS AND PISTONS 0403 > 0403-2 - CONNECTING ROD, PISTON, RINGS AND LINER [01D23]

KEY	PART NO.	PART NAME	QTY	REMARKS
1	R74195	SCREW	8	
2	BUSHING	4	(R56186 NO LONGER AVAILABLE)
3	RE53716	CONNECTING ROD	4	(MARKED R116851) (SUB FOR AR66400) (MARKED R56187)
4	R54114	SNAP RING	8	
5	PIN	4	(R124230 NO LONGER AVAILABLE,FURNISH RE63913)
6	RE66820	PISTON RING KIT	4	(SUB FOR RE15674 AND RE48818)
7	PISTON	4	(MARKED AR96389) (AR96389 NO LONGER AVAILABLE,FURNISH RE19833)
7	PISTON	4	(MARKED RE28920) (RE28920 NO LONGER AVAILABLE,FURNISH RE53073)
8	R121867	CYLINDER LINER	4	(SUB FOR R80500) (SUB RE500024)
9	AR65507	O-RING KIT	4	
10	RE19833	KIT	4	(SUB FOR RE19832) (USED WITH PISTON MARKED AR96389)
10	RE53073	PISTON-LINER KIT	4	(SUB FOR RE28977) (USED WITH PISTON MARKED RE28920)
11	AR97517	BEARING	4	STANDARD (SET OF (2) R54801)
11	BEARING	4	(AR97652 NO LONGER AVAILABLE) 0.05 MM (.002") UNDERSIZE (SET OF (2) R73595)
11	AR97653	BEARING	4	0.25 MM (.010") UNDERSIZE (SET OF (2) R73596)
11	AR97654	BEARING	4	0.51 MM (.020") UNDERSIZE (SET OF (2) R73597)
11	AR97655	BEARING	4	0.76 MM (.030") UNDERSIZE (SET OF (2) R73598)
12	RE500024	CYLINDER LINER	4	
13	BUSHING	4	
14	RE63913	KIT	4	

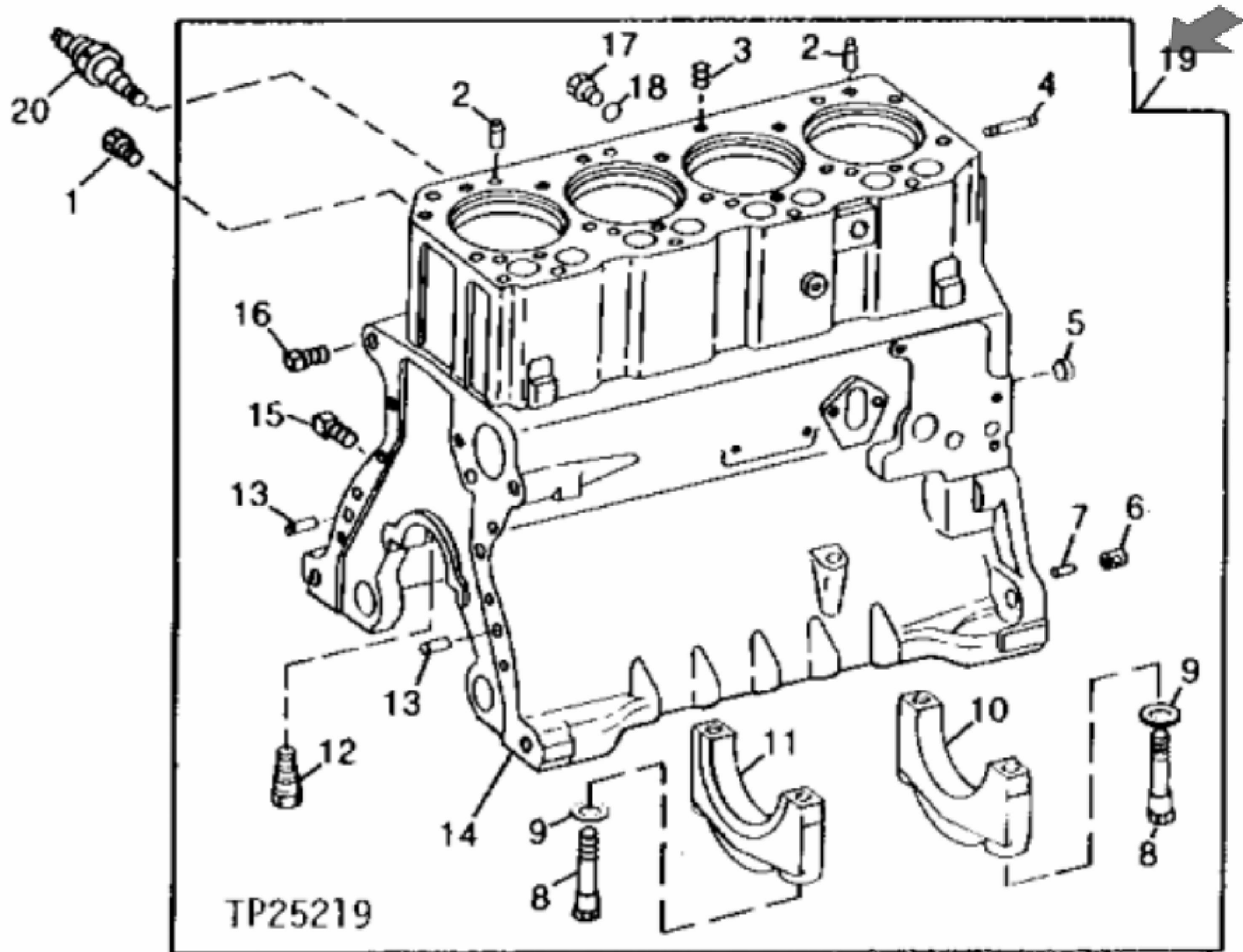

<https://www.ebooklibonline.com>

Hello dear friend!

Thank you very much for reading.

Enter the link into your browser.

The full manual is available for immediate download.

<https://www.ebooklibonline.com>