

- 1 - Bolt
- 2 - Washer
- 3 - Washer

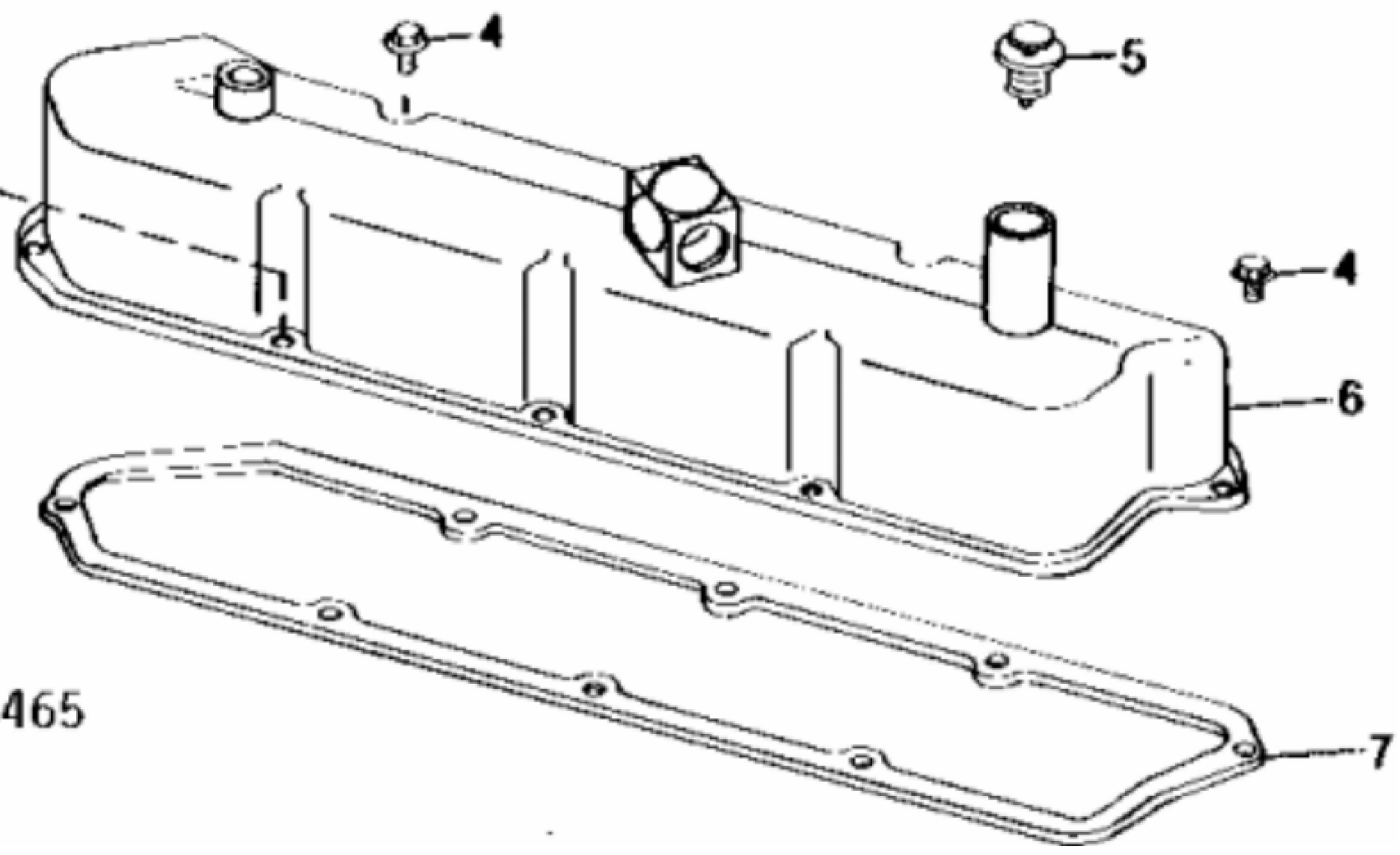

TP16465

KEY	PART NO.	PART NAME	QTY	REMARKS	
1	19H2036	CAP SCREW	1	1/4" X 7/8"	
2	12H302	LOCK WASHER	1	1/4"	
3	R64764	WASHER	1		
4	AR103811	SCREW WITH WASHER	8	(SUB FOR AR100124)	
5	AR65864	FILLER CAP	1		
6	AR71130	VALVE COVER	1		
7	R73521	GASKET	1		

**<https://www.ebooklibonline.com>**

Hello dear friend!

Thank you very much for reading.

Enter the link into your browser.

The full manual is available for immediate download.

**<https://www.ebooklibonline.com>**

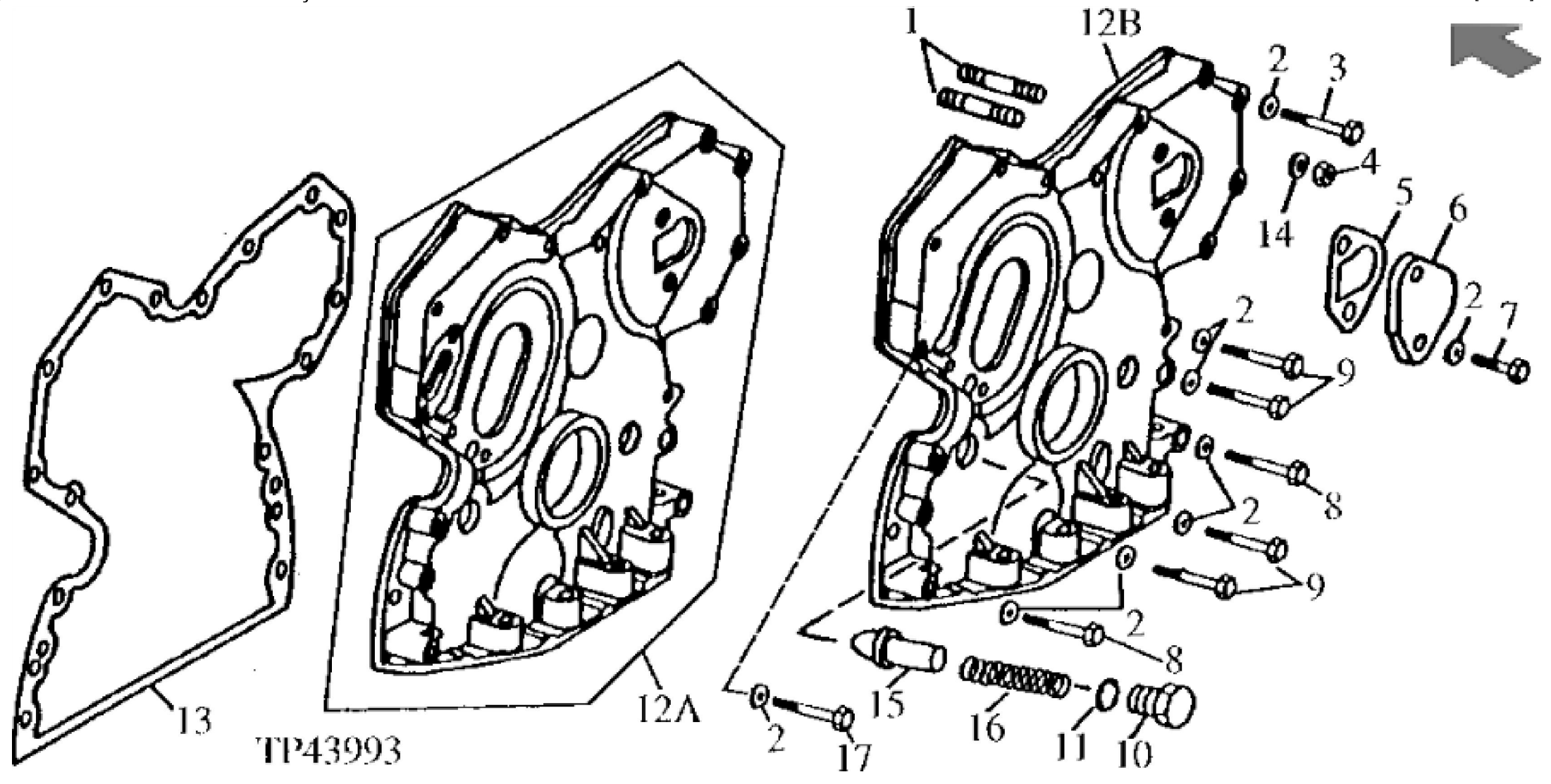

TP43993



KEY	PART NO.	PART NAME	QTY	Engine Serial No.	REMARKS
1	R122226	STUD	2		(SUB FOR T33279)
2	24H1304	WASHER	AR		13/32" X 23/32" X 0.120"
3	19H3385	CAP SCREW	5		1/2" X 1-1/8"
4	N10215	LOCK NUT	2		3/8", (SUB FOR 14H812, THIS APPLICATION)
5	R125066	GASKET	1		(SUB FOR R78366 OR R97773)
6	R126041	COVER	1		(SUB FOR T20362)
7	R124277	CAP SCREW	2		(SUB FOR R122618, THIS APPLICATION)
8	19H3733	SCREW	2		3/8" X 2-1/2"
9	19H3408	SCREW	5		3/8" X 1-3/4"
10	T27657	FITTING PLUG	1		
11	A4827R	WASHER	1		25.400 X 31.700 X 1.500 MM (1" X 1.248" X 0.059")
12A	RE39252	COVER	1	____-426683	(SUB FOR RE27895)
12B	RE56443	COVER	1	426684- ____	
13	R126513	GASKET	1		(SUB FOR R97454, T20155, R119269 OR R121314)
14	12H304	LOCK WASHER	AR		3/8"
15	R83169	VALVE	1		
16	T27658	SPRING	1		
17	19H1819	CAP SCREW	1	426684- ____	3/8" X 2-1/8"



**Suggest:**

**For more complete manuals. Please go to the home page.**

**<https://www.ebooklibonline.com>**

**If the above button click is invalid. Please download this document first, and then click the above link to download the complete manual.**

**Thank you so much for reading**

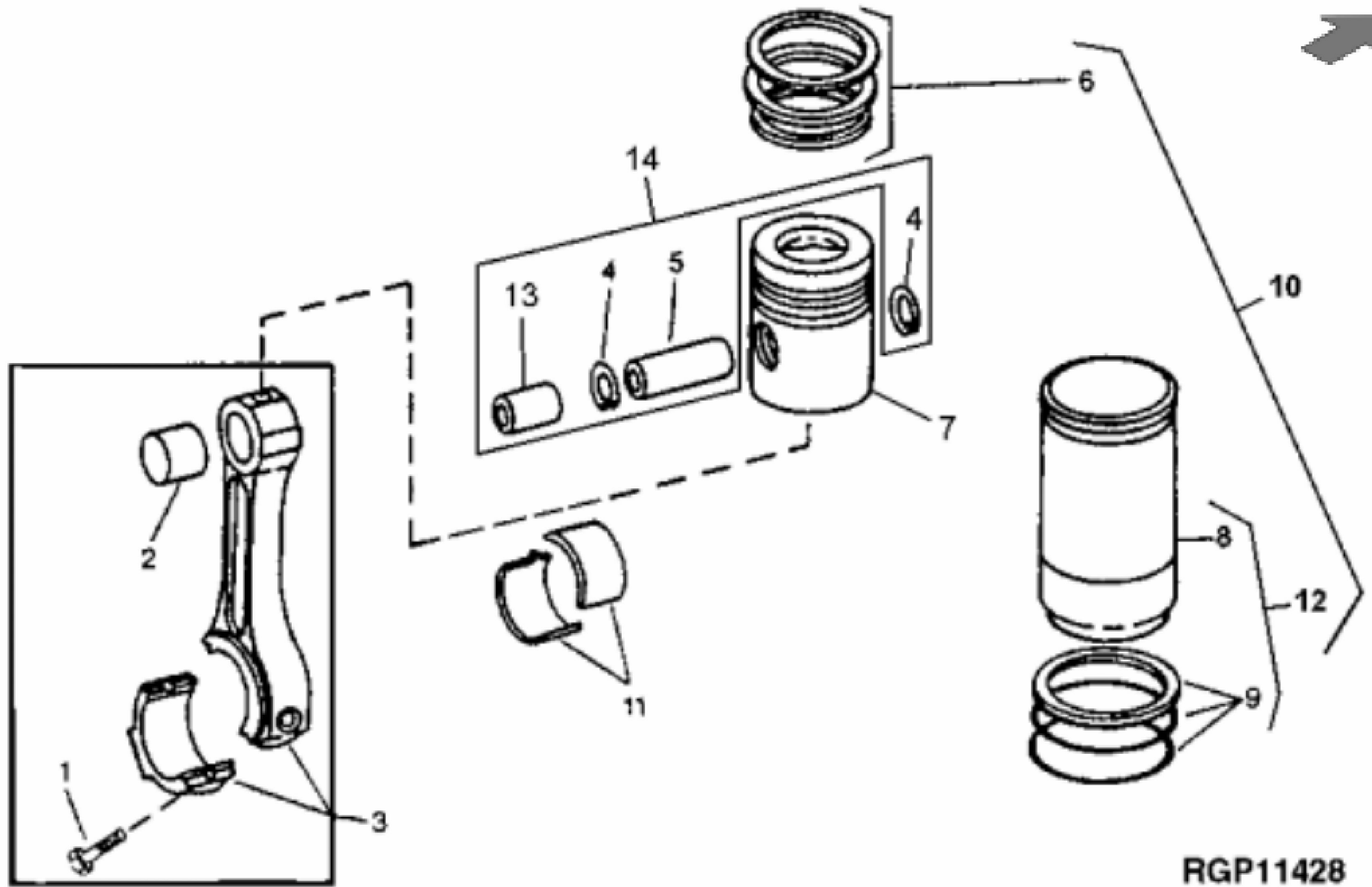

RGP11428

KEY	PART NO.	PART NAME	QTY	Engine Serial No.	REMARKS
1	R74195	SCREW	8		
2	.....	BUSHING	4		( R56186 NO LONGER AVAILABLE)
3	RE53716	CONNECTING ROD	4		(MARKED R116851) (SUB FOR AR66400) (MARKED R56187) (SUB (4) SE500746)
3	SE500746	CONNECTING ROD REMAN	4		(REMANUFACTURED)
4	R54114	SNAP RING	8		
5	R56188	PISTON PIN	4		( R124230 NO LONGER AVAILABLE,FURNISH RE63913)
6	RE507852	PISTON RING KIT	4		(SUB FOR RE15674, RE48818, RE66820)
7	.....	PISTON	4	____-216421	( AR96389 NO LONGER AVAILABLE,FURNISH RE19833)
7	.....	PISTON	4	216422-____	( RE28920 NO LONGER AVAILABLE,FURNISH RE53073)
8	R121867	CYLINDER LINER	4		(SUB FOR R80500) (SUB RE500024)
9	AR65507	O-RING KIT	4		
10	RE19833	KIT	4	____-216421	(SUB FOR RE19832)
10	RE53073	PISTON-LINER KIT	4	216422-____	(SUB FOR RE28977)
11	AR97517	BEARING	4		STANDARD (SET OF (2) R54801)
11	.....	BEARING	4		( AR97652 NO LONGER AVAILABLE) 0.05 MM (.002") UNDERSIZE (SET OF (2) R73595)
11	AR97653	BEARING	4		0.25 MM (.010") UNDERSIZE (SET OF (2) R73596)
11	AR97654	BEARING	4		0.51 MM (.020") UNDERSIZE (SET OF (2) R73597)
11	AR97655	BEARING	4		0.76 MM (.030") UNDERSIZE (SET OF (2) R73598)
12	RE500024	CYLINDER LINER	4		
13	.....	BUSHING	4		
14	RE63913	KIT	4		

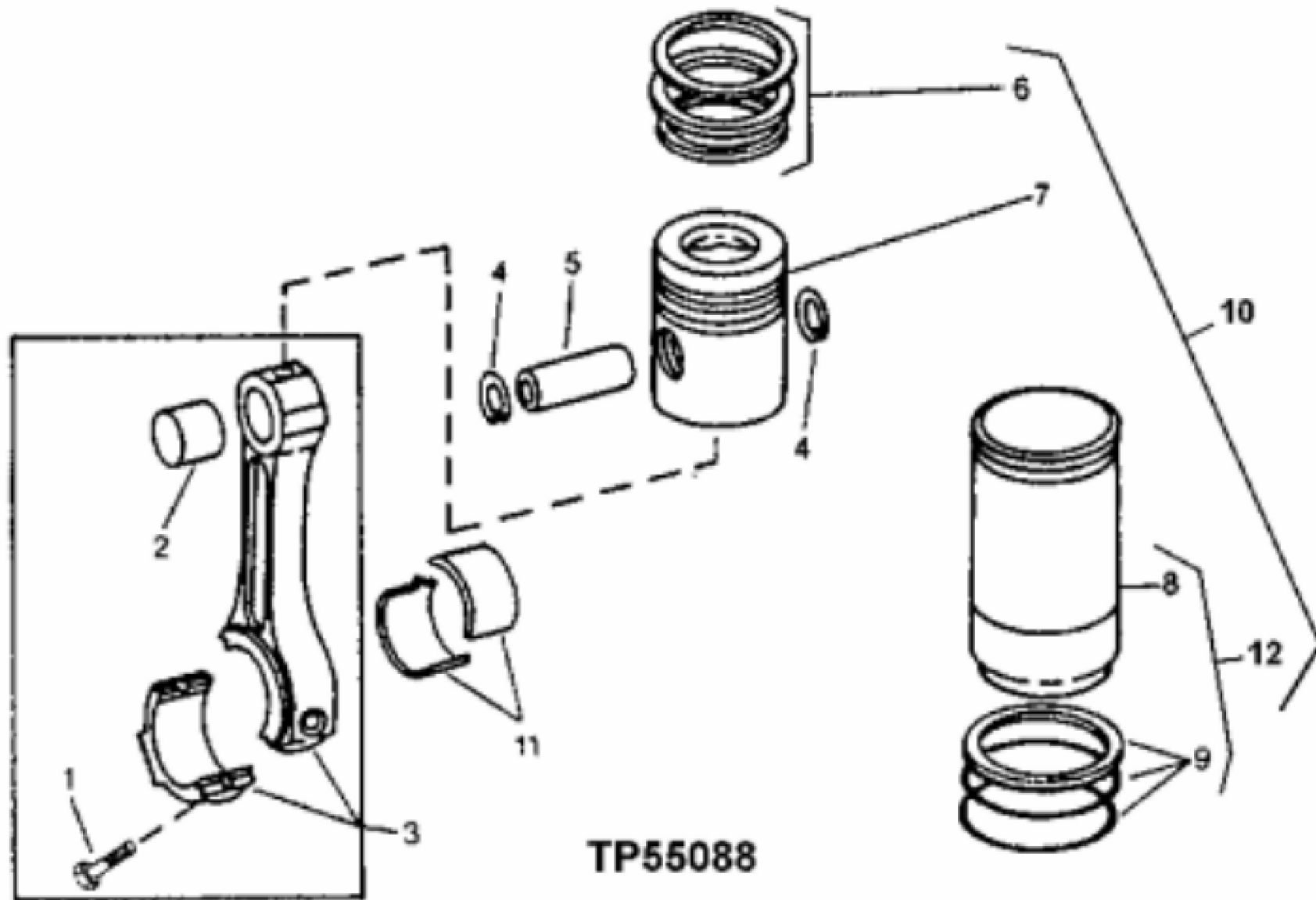

TP55088

**<https://www.ebooklibonline.com>**

Hello dear friend!

Thank you very much for reading.

Enter the link into your browser.

The full manual is available for immediate download.

**<https://www.ebooklibonline.com>**