

TP17556

KEY	PART NO.	PART NAME	QTY	Engine Serial No.	REMARKS	
1	AR103811	SCREW WITH WASHER	8		(SUB FOR AR100124)	
2	AR65864	FILLER CAP	1			
3A	AR75747	COVER	1	____-687810		
3B	RE22290	VALVE COVER	1	687811-____		
4	R73521	GASKET	1		(SUB FOR AR100596)	

<https://www.ebooklibonline.com>

Hello dear friend!

Thank you very much for reading.

Enter the link into your browser.

The full manual is available for immediate download.

<https://www.ebooklibonline.com>

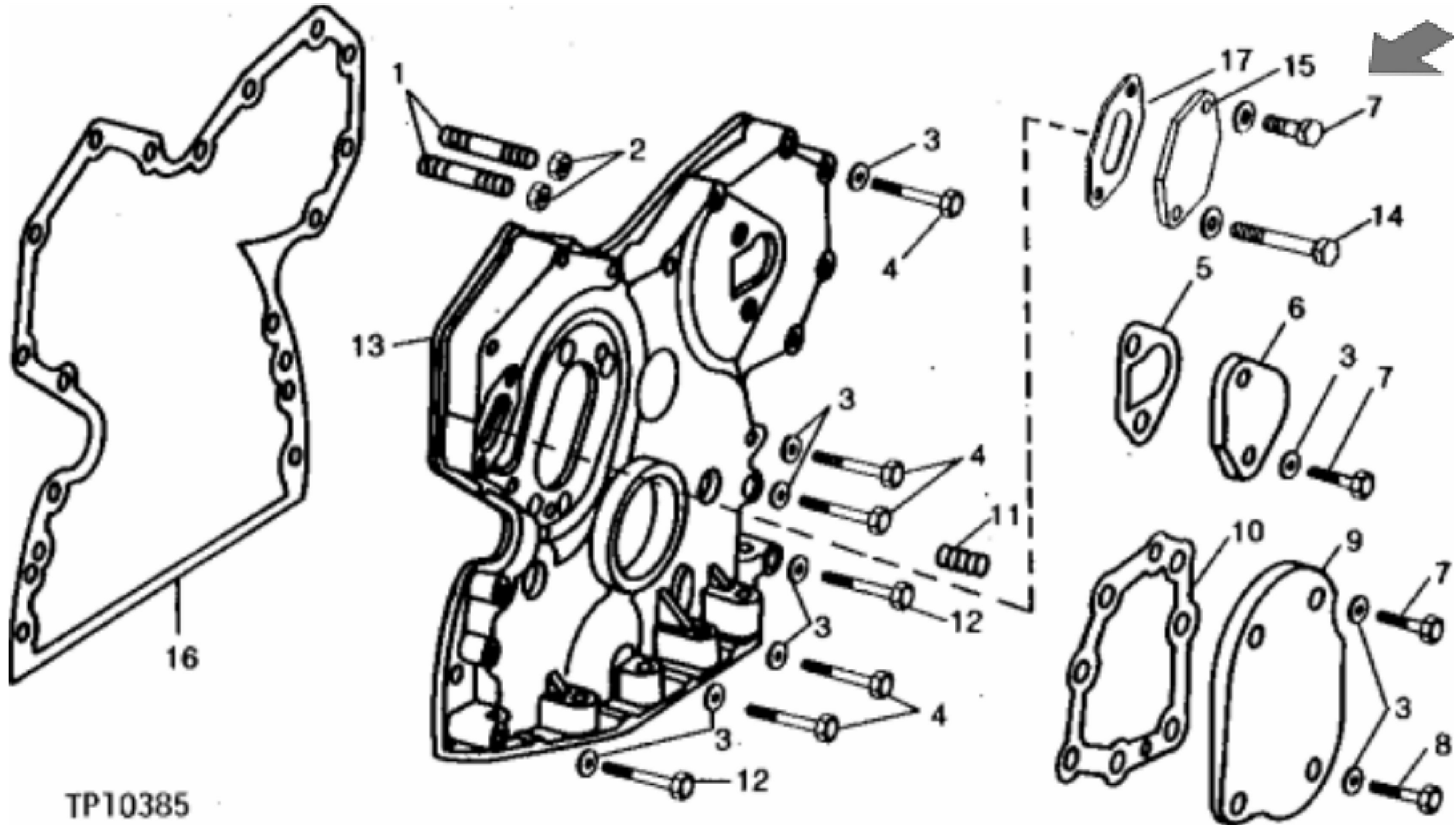

TP10385

KEY	PART NO.	PART NAME	QTY	REMARKS
1	R122226	STUD	2	(SUB FOR R122226)
1	R84984	STUD	2	(USE WITH RE25595 CYLINDER BLOCK)
2	14H812	NUT	2	3/8"
2	14H774	NUT	2	3/8", (USE WITH RE25595 CYLINDER BLOCK)
3	24H1304	WASHER	AR	13/32" X 23/32" X 0.120"
4	19H3065	CAP SCREW	10	3/8" X 2"
5	R125066	GASKET	1	(SUB FOR R78366 OR R97773)
6	R126041	COVER	1	(SUB FOR T20362)
7	19H2284	CAP SCREW	4	3/8" X 7/8"
7	R122618	SCREW	3	(USE WITH T23260 OR (2) R126041)
8	19H1726	CAP SCREW	1	3/8" X 2-1/4"
9	T20272	COVER	1	
10	T20273	GASKET	1	
11	15H275	PIPE PLUG	1	3/8" X 2-1/2"
12	19H3031	CAP SCREW	2	3/8" X 2-1/2"
13	AR58196	COVER	1	(MARKED R52880) (ALSO ORDER T20272, T20273, 15H275, 19H1726, (3) 19H2284 AND (4) 24H1304)
14	19H1726	CAP SCREW	1	3/8" X 2-1/4"
15	T23260	COVER	1	
16	R126513	GASKET	1	(SUB FOR T20155, R97454, R119269 OR R121314)
17	R97352	GASKET	1	(SUB FOR T20336)



Suggest:

For more complete manuals. Please go to the home page.

<https://www.ebooklibonline.com>

If the above button click is invalid. Please download this document first, and then click the above link to download the complete manual.

Thank you so much for reading

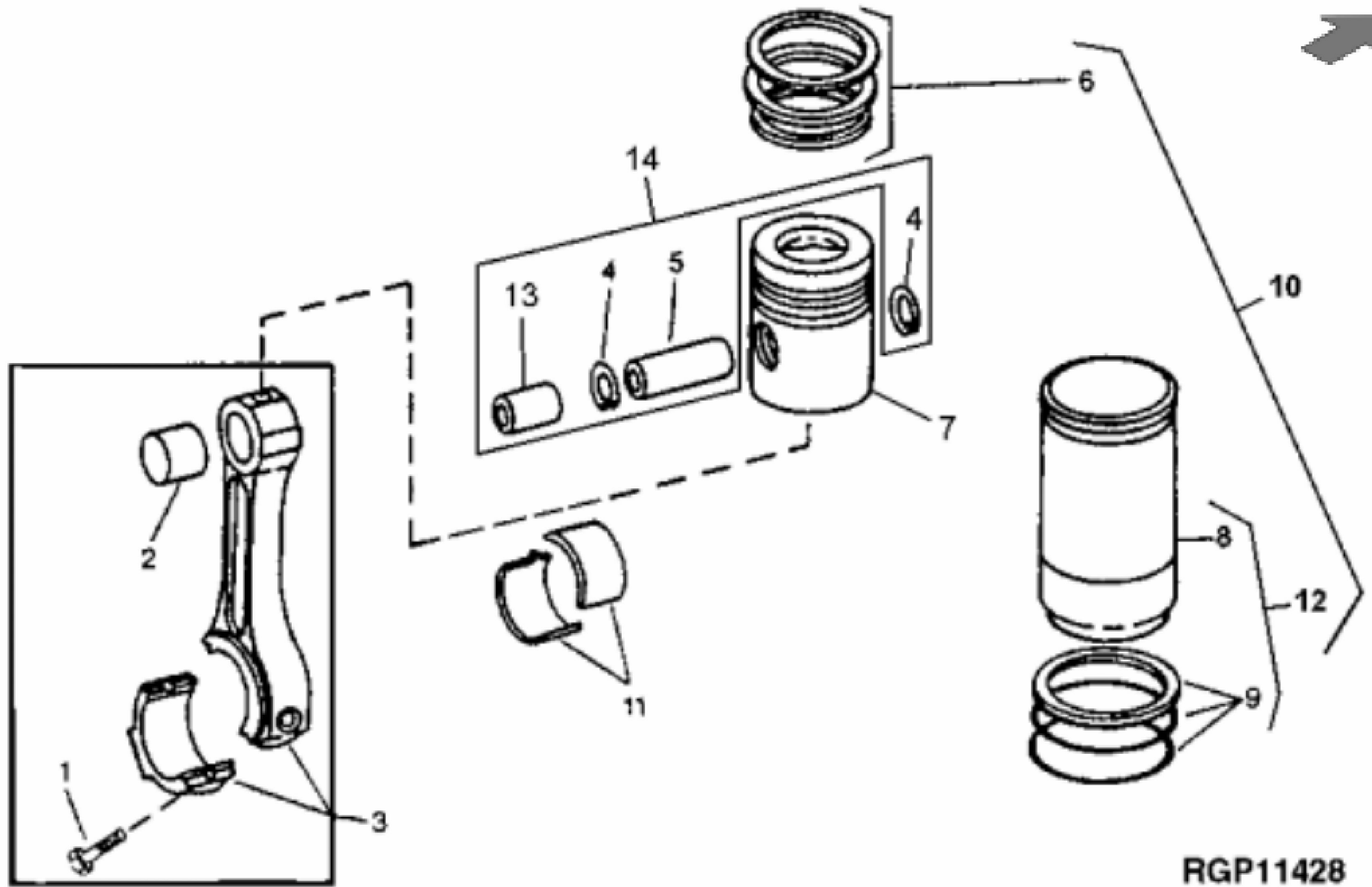

RGP11428

John Deere > Construction And Forestry > EXCAVATOR > 490 - EXCAVATOR > 490 Excavator > 4 ENGINE 4 > CONNECTING RODS AND PISTONS 0403 > 0403-2 - CONNECTING ROD, PISTON, RINGS AND LINER (6359) [01C12]

KEY	PART NO.	PART NAME	QTY	REMARKS
1	R80033	CAP SCREW	12	
2	BUSHING	6	(R56186 NO LONGER AVAILABLE)
3	RE42733	CONNECTING ROD	6	(MARKED R80032 OR R113612) (SUB FOR RE16494) (MARKED R80032)
4	R54114	SNAP RING	12	
5	PIN	12	(R124230 NO LONGER AVAILABLE,FURNISH RE63913)
6	RE66820	PISTON RING KIT	6	(SUB FOR RE15674 AND RE48818)
7	PISTON	6	(FURNISH RE22678)
8	R116281	CYLINDER LINER	6	(SUB FOR R51726, THIS APPLICATION) (ALSO USE AR54749 LUBRICANT FOR CYLINDER LINER PACKING INSTALLATION) (SUB FOR R90059) (SUB RE500023) (SUB (4) RE30250) (RE30250 PISTON AND LINER KIT)
9	AR65507	O-RING KIT	6	
10	RE22678	PISTON-LINER KIT	6	(USE RE33115 IF AVAILABLE) (WHEN NO LONGER AVAILABLE USE RE22678)
11	AR71080	BEARING	6	(SET OF (2) R58980)
11	BEARING	6	(AR76128 NO LONGER AVAILABLE) .05 MM (.002") UNDERSIZE (SET OF (2) R62072)
11	AR76129	BEARING	6	.25 MM (.010") UNDERSIZE (SET OF (2) R62073)
11	AR76130	BEARING	6	.51 MM (.020") UNDERSIZE (SET OF (2) R62074)
11	AR76131	BEARING	6	.76 MM (.030") UNDERSIZE (SET OF (2) R62075)
12	RE500023	KIT	6	
13	BUSHING	6	
14	RE63913	KIT	6	

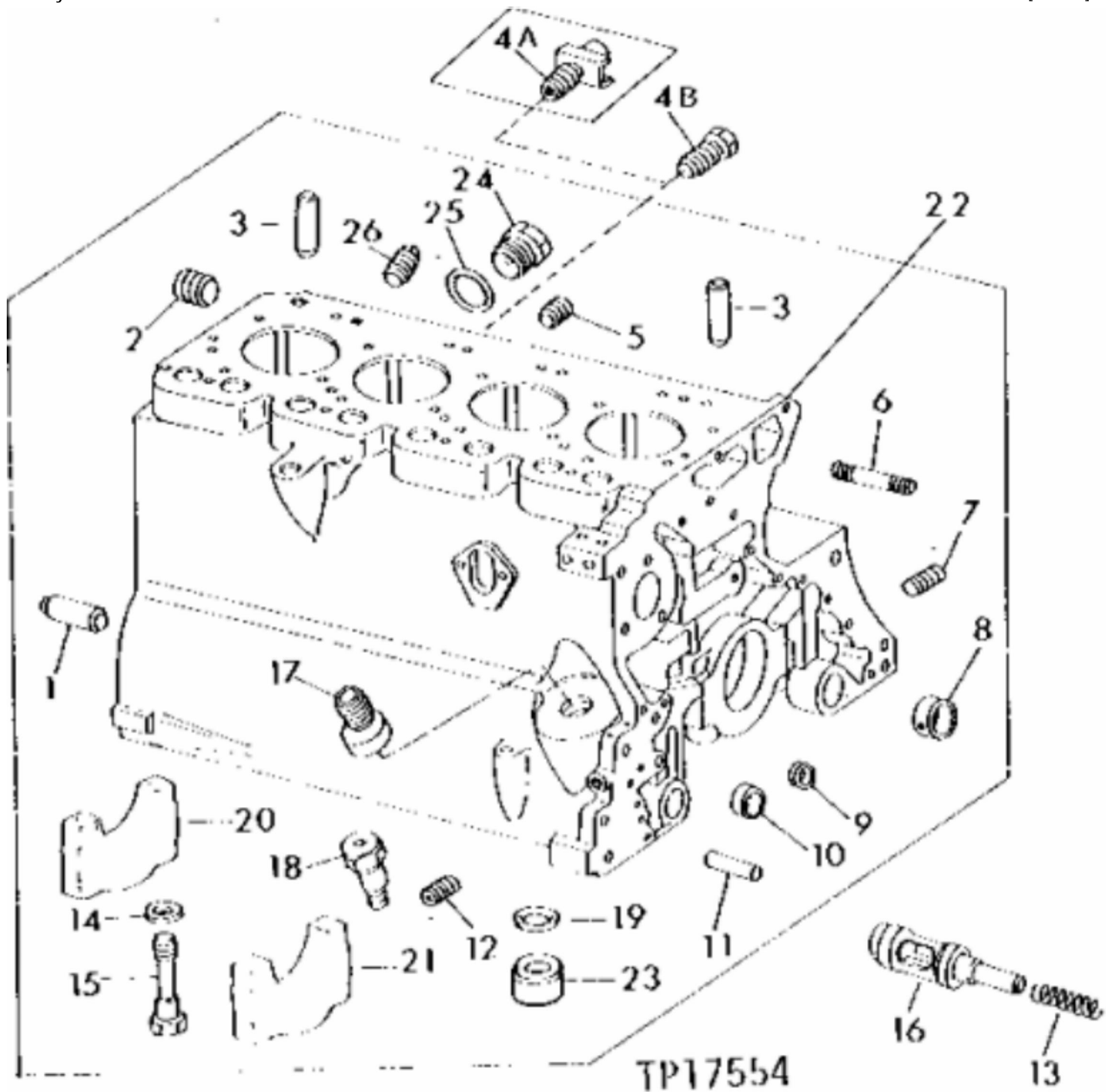

<https://www.ebooklibonline.com>

Hello dear friend!

Thank you very much for reading.

Enter the link into your browser.

The full manual is available for immediate download.

<https://www.ebooklibonline.com>