

# **YANMAR**

# **EXCAVATOR**

## **OPERATION & MAINTENANCE MANUAL**

### **⚠ WARNING**

- Never attempt to operate or service this Excavator until you have first read and understood all of the applicable Safety Instructions that are set forth in this Manual.

The failure to comply with all relevant Safety Instructions could result in bodily injury.

- To assure that this Manual will be conveniently available to future users, always return it to its storage compartment, when it is not being used.

## **LGBVIO30/35-2.0(EP)**

---

**MODEL**    **VIO30-2 VIO35-2 (EP)**

---

S/N 20501 & Above

# 1. Introduction

This Operation and Maintenance Manual for the YANMAR ViO30-2 / ViO35-2 Excavator is designed to provide you with important information and suggestions necessary for using the machine with safety and efficiency. Please be sure to read through the manual before using the machine, to make yourself familiar with the procedures and instructions for operating, inspecting and servicing. Keep in mind that failure to observe the precautions given in the manual or using any procedures not prescribed in the manual may cause a serious accident.

## **WARNING**

**Improper use of the machine may lead to hazards which can result in death or serious injury. Personnel engaged in operating and maintaining the machine are required to familiarize themselves with the contents of the manual before setting about their job.**

- **Do not attempt to operate the machine before making yourself familiar with the contents of the manual.**
- **Personnel responsible for using the machine must keep the manual at hand and review it periodically.**
- **If the manual should be lost or damaged, promptly order a new copy from the dealer.**
- **When you transfer the machine to another user, always transfer the manual as well.**
- **We at YANMAR provide customers with products in compliance with all applicable your country's regulations and industrial standards. If you are using a YANMAR machine purchased abroad, the machine may lack some safety devices. Please consult your dealer to confirm whether or not that machine is in compliance with all applicable your country's regulations and industrial standards.**
- **Some machine specifications may differ from those which are described in this manual because of improvements in its design and performance. If you have any questions about the contents of the manual, don't hesitate to contact your dealer.**
- **Important safety instructions have been presented throughout this manual, and have been summarized in PART ONE : SAFETY. Be sure to review these pages and pay heed to those safety instructions before proceeding to operate the machine.**

**<https://www.ebooklibonline.com>**

Hello dear friend!

Thank you very much for reading.

Enter the link into your browser.

The full manual is available for immediate download.

**<https://www.ebooklibonline.com>**

## 2. Safety Information

- The following Signal Words have been used in this Manual and on the Safety Signs to indicate the seriousness of the hazards that could be encountered by failing to comply with the applicable Product Warnings, as follows:

**⚠ DANGER**

Could result in death or catastrophic bodily injury.

**⚠ WARNING**

Could result in bodily injury.

**⚠ CAUTION**

Could result in property damage.

**IMPORTANT**

The signal Word "IMPORTANT" has been utilized in this Manual to denote those User Directions that must be followed to assure the safe operation and maintenance of the Excavator.

- **WARNING** : Never attempt to operate or service this Excavator until you have first read and understood all of the applicable Product Warnings and User Directions that are set forth in this Manual and on the Safety Signs that are affixed to this Excavator.

The failure to comply with all relevant Safety Instructions could result in bodily injury.

- **WARNING** : Never modify the design of this Excavator or its engine; never remove or disable any of the installed safety guards or devices; and never use any unauthorized attachments in the operation of this equipment.

The implementation of any unauthorized design modifications or the use of unauthorized attachments could result in bodily injury.

Furthermore, since those actions would expressly violate the terms of Yanmar's Product Warranty, the applicable Warranty would also be voided.

In this Manual, the major sections of the product are designated as follows:

**Machine**.....refers to the entire product.

**Machine base**.....refers to the section consisting of the upper-structure and the undercarriage.

**Implement**.....refers to the section consisting of the arm, boom and bucket or other attachment.

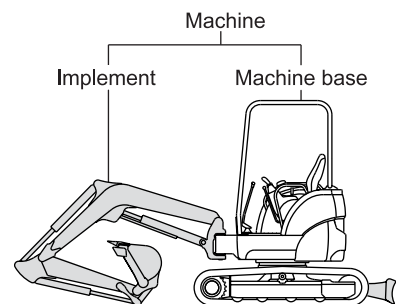

## 3. Product Overview

### 3-1. Intended uses

The ViO30-2 / ViO35-2 Excavator is intended to perform the following tasks:

- Digging
- Leveling of ground
- Shoveling
- Ditching and Guttering
- Loading

**The machine should not be used for unintended tasks**

For the details of how to work with the machine, refer to OPERATION Section "13-13. Operations using the bucket".

### 3-2. Break in period

The machine should not be subjected to severe stresses and loads during the initial break in period although it has been prepared well and stringently inspected before shipping. Otherwise the machine's performance may be affected and its service life shortened. Thus it is essential to break in the machine for the first approx. 100 service hours (reading of the hourmeter).

In breaking in the machine:

- You should warm up the engine by idling for 5 minutes before starting operations.
- You should not operate the machine under heavy loads or at high speed.
- You should not start and accelerate the engine too abruptly, or stop it too abruptly.
- You should not change travel direction too abruptly.

The safety instructions for operation and maintenance that are presented in this Manual are applicable to each of the intended tasks. Never misuse this machine by violating the applicable safety instructions or by attempting to perform unintended tasks, because of the danger of serious bodily injury.

### 3. Product Overview

#### 3-3. Conditions to insure compliance with EPA emission standards

##### *Conditions de conformité avec les standards d'émission EPA*

An EPA approved engine has been mounted on this machine. The following are the conditions that must be met in order to insure that the emission during operation meets the EPA standards. Be sure to follow these.

- The surrounding conditions should be as follows.
  - (1) Ambient temperature : -4 to 104°F (-20 to 40°C)
  - (2) Relative humidity : 80% or lower
- The fuel and lube oil used should be as follows.
  - (1) Fuel : The diesel light oil [ISO 8217 DMA, BS 2869 A1 or A2 (Cetane No.45 min.)]
  - (2) Lube oil : Type API, class CD
- Do not remove the seals limiting the amount of fuel injected and the speed.
- Be sure to carry out inspections.

Follow the basic guidelines outlined in Section "24. Maintenance Table" of this manual, and keep a record of the results. Pay particular attention to these important points: replacing the lube oil and lube oil filter, cleaning the air cleaning the air cleaner element and the radiator fins.

- Warranty period for emission parts.

If the schedule of periodic maintenance outlined in Section "24. Maintenance Table" is followed, the warranty period is determined by the age of the engine or number of hours of operation as indicated below.

Name of parts	Warranty period (hours of operation / age)
Fuel injection pump assembly	1500 / 2 (Range < 19 kW)
Fuel injection nozzle assembly	

*Un moteur thermique agréé EPA est installé sur cette machine. A la suite figurent les conditions d'utilisation permettant de satisfaire au standard EPA; il est impératif de les respecter.*

- *Environnement extérieur:*

- (1) *Température ambiante : -4 à 104°F (-20 à 40°C)*
- (2) *Humidité relative : 80 % au moins*

- *Carburant et huiles à utiliser*

- (1) *Carburant : diesel léger (ISO 8217 DMA, BS 2869 A1 ou A2 (Cetane No. 45 min))*
- (2) *Huiles : type API, classe CD*

- *Ne pas retirer les joints limitant la quantité de carburant injecté et la vitesse*

- *Respecter les inspections périodiques*

*Suivre les indications figurant dans ce manuel (Table de maintenance 24) et garder une trace des résultats. Faire très attention aux points importants suivant: remplacer l'huile et le filtre à huile, nettoyer l'élément de filtre à air et le radiateur.*

- *Période de garantie pour l'émission des particules*

*Si la maintenance est faite conformément au programme figurant dans ce manuel, la période de garantie est déterminée par l'âge et le nombre d'heures de moteur comme indiqué ci-dessous.*

Désignation des pièces	Période de garantie (heures / années)
Pompe à injection	1500 / 2 (Gamme < 19 kW)
Injecteurs	

## **4. Operation License**

Before you operate this machine, confirm the licensing requirements that are applicable to the operation of this machine.

Comply with all applicable laws.

Ask your dealer about licensing requirements.

## 5. Ordering Replacement Parts and Service Call

### 5-1. Location of machine serial number plate

The machine serial number plate is located on the turning frame as illustrated at right. Never remove the plate for any reason.

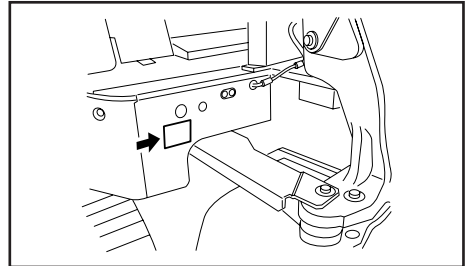

### 5-2. Location of engine serial number plate

The engine serial number plate is located on the top of the cylinder head cover. Never remove the plate for any reason.

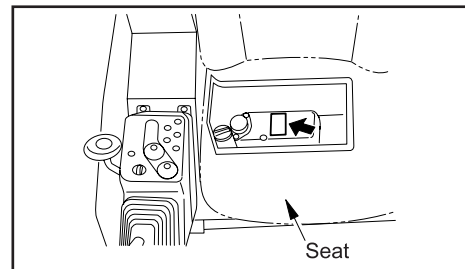

### 5-3. Location of EPA emission control plate

#### *Localisation de la plaque signalétique EPA*

The EPA emission control plate are located on the engine and engine hood as illustrated at right. Never remove the plate for any reason.

*La plaque signalétique est fixée sur le moteur (voir illustration à droite).*

*En aucun cas ne retirer cette plaque.*

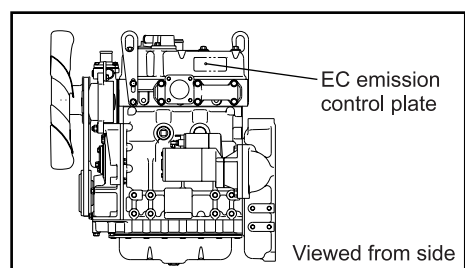
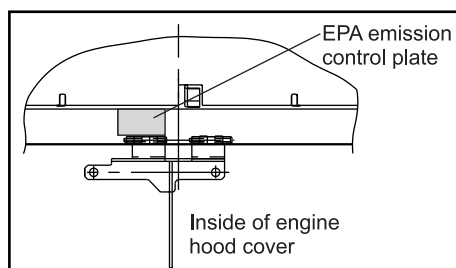
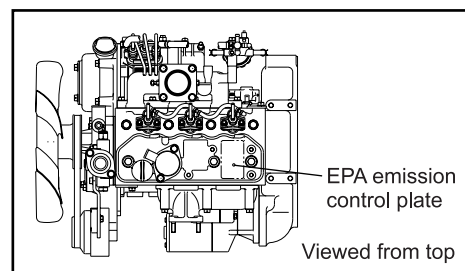

**5-4. Warranty term of the exhaust emission control system and parts**

*Durée de garantie pour l'ensemble et les pièces du système de contrôle d'échappement*

Warranty term of the exhaust emission control system and parts shall be for the first two years starting from the date of delivery to the original retail purchaser, or for 1500 operating hours, whichever occurs first.

Emission related parts are as follows.

- (1) Fuel injection pump assembly.
- (2) Fuel injection nozzle assembly.

*Celles ci est de 2 ans à compter de la date de mise à disposition pour le premier acheteur, ou 1500 heures de service, le premier des deux termes atteint.*

*Les pièces concernées sont:*

- (1) Pompe à injection
- (2) Injection

**5-5. Ordering replacement parts and service calls**

When ordering replacement parts or calling for service, let your dealer know the model designation, the machine serial number, and the engine serial number on the machine serial number plate as well as the reading of the hourmeter.

- Machine serial number plate

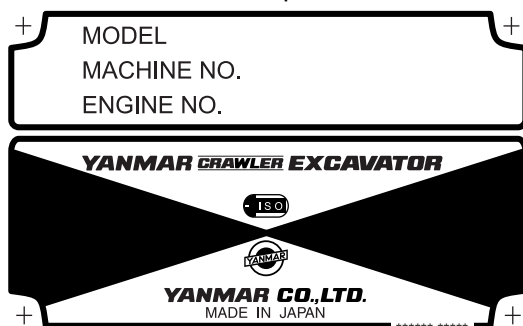

- Hourmeter

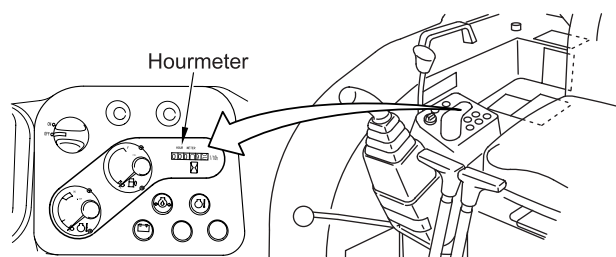

## 6. Contents

1. Introduction .....	0-1
2. Safety Information .....	0-2
3. Product Overview .....	0-3
3-1. Intended uses .....	0-3
3-2. Break in period .....	0-3
3-3. Conditions to insure compliance with EPA emission standards .....	0-4
4. Operation License .....	0-5
5. Ordering Replacement Parts and Service Call.....	0-6
5-1. Location of machine serial number plate .....	0-6
5-2. Location of engine serial number plate .....	0-6
5-3. Location of EPA emission control plate .....	0-6
5-4. Warranty term of the exhaust emission control system and parts .....	0-7
5-5. Ordering replacement parts and service calls .....	0-7
6. Contents .....	0-8

### SAFETY

7. Basic Precautions .....	1-2
8. Operating Precautions .....	1-6
8-1. Precautions before starting the engine .....	1-6
8-2. Precautions for starting the engine, working and parking .....	1-8
8-3. Precautions for transportation .....	1-13
8-4. Precautions for the battery .....	1-14
8-5. Precautions for towing .....	1-15
8-6. Precautions for hooked bucket .....	1-16
9. Precautions for Servicing .....	1-19
9-1. Precautions before servicing .....	1-19
9-2. Precautions during servicing .....	1-21
10. Safety Messages (Warning Labels) .....	1-25
10-1. Location of warning labels .....	1-25

### OPERATION

11. Identification of Important Parts .....	2-2
11-1. Overview of the machine .....	2-2
11-2. Controls and switches .....	2-3
12. Description of Control Devices .....	2-4
12-1. Monitor .....	2-4
12-2. Switch .....	2-7
12-3. Control levers and pedals .....	2-10
12-4. Engine hood rear cover .....	2-14
12-5. Storage space for the operation & maintenance manual .....	2-14
12-6. Windshield (for cabin) .....	2-15

---

12-7. Operator's seat .....	2-17
12-8. Ash tray (for cabin).....	2-18
12-9. Headlight.....	2-18
12-10. Air outlet (for cabin).....	2-19
12-11. Outside air intake and inside air circulation select lever (for cabin) .....	2-19
12-12. Right window glass (for cabin).....	2-19
12-13. Cabin side door.....	2-20
12-14. Replenishment of windshield washer fluid .....	2-20
12-15. Fuse .....	2-21
13. Operating Instructions .....	2-22
13-1. Checking before starting the engine .....	2-22
13-2. Starting up the engine.....	2-32
13-3. Operating and checking instructions after starting the engine .....	2-35
13-4. Traveling .....	2-37
13-5. Steering.....	2-40
13-6. Stopping the machine .....	2-42
13-7. Swinging the upperstructure .....	2-43
13-8. Operating the implements.....	2-44
13-9. Precautions for operating the implement .....	2-45
13-10. Precautions for working .....	2-48
13-11. Precautions for going up and down a slope.....	2-49
13-12. Escaping from the mud .....	2-51
13-13. Operations using the bucket .....	2-52
13-14. Replacing the bucket .....	2-53
13-15. Parking the machine .....	2-55
13-16. Inspection requirements after completing operation .....	2-56
13-17. Stopping the engine.....	2-57
13-18. Inspection requirements after stopping the engine .....	2-58
13-19. Locking.....	2-58
13-20. Handling the rubber crawler (for rubber crawler type) .....	2-59
13-21. Handling hydraulic P.T.O. ....	2-64
13-22. Handling quick coupler.....	2-69
14. Transportation .....	2-78
14-1. Loading and unloading the machine .....	2-78
14-2. Precautions for loading the machine.....	2-80
14-3. Precautions for transporting the machine .....	2-81
14-4. Suspending the machine .....	2-82
15. Care and Service in Cold Weather.....	2-84
15-1. Preparing for cold weather.....	2-84
15-2. Precautions after a day's work.....	2-86
15-3. After cold weather ends .....	2-86

## 6. Contents

---

16. Long-term Storage .....	2-87
16-1. Before storing.....	2-87
16-2. Storing.....	2-88
16-3. Using the machine again .....	2-88
17. Troubleshooting .....	2-89
17-1. Phenomena that are not breakdowns .....	2-89
17-2. Towing .....	2-90
17-3. If the battery is overdischarged.....	2-91
17-4. Troubleshooting .....	2-96

### **MAINTENANCE**

18. Precautions for Servicing .....	3-2
19. Basic Servicing Practices.....	3-5
19-1. Oils, fuel, and cooling water .....	3-6
19-2. Electrical equipment.....	3-9
19-3. Hydraulic system.....	3-10
20. Consumables .....	3-11
21. Fueling, Oiling and Greasing Based on Temperature Range .....	3-12
21-1. Fuel and oil .....	3-12
21-2. Cooling water .....	3-12
22. Standard Tightening Torque for Bolts and Nuts.....	3-13
22-1. Required tools.....	3-13
22-2. Torque table.....	3-14
23. Replacing Essential Parts Periodically.....	3-15
24. Maintenance Table.....	3-17
24-1. Table of service time intervals .....	3-17
24-2. Service intervals when using the hydraulic breaker.....	3-21
25. Procedures for Maintenance .....	3-22
25-1. First services.....	3-22
25-2. Nonperiodic services.....	3-23
25-3. Checking before start-up.....	3-40
25-4. Maintenance every 50 service hours .....	3-47
25-5. Maintenance every 100 service hours .....	3-49
25-6. Maintenance every 200 service hours .....	3-50
25-7. Maintenance every 250 service hours .....	3-57
25-8. Maintenance every 400 service hours .....	3-58
25-9. Maintenance every 500 service hours .....	3-61
25-10. Maintenance every 1000 service hours .....	3-62
25-11. Maintenance every 2000 service hours .....	3-66

### **SPECIFICATIONS AND DIMENSIONAL DIAGRAMS**

26. Specifications and Dimensional Diagrams.....	4-2
--	-----

**OPTIONAL PARTS AND ATTACHMENTS**

27. General Precautions .....5-2  
    27-1. Safety precautions .....5-2  
    27-2. Precautions for mounting an attachment (implement) .....5-3  
28. Handling the Hooked Bucket.....5-4  
    28-1. Checking the hooked bucket for damage .....5-4  
    28-2. Prohibitions .....5-4  
    28-3. Precautions .....5-4  
29. Optional Parts and Attachments .....5-5  
    29-1. Optional parts and attachments .....5-5  
30. Noise .....5-7

**NOTES**

31. Maintenance Log .....6-2  
32. Notes .....6-6



# SAFETY

## **WARNING**

**Never attempt to operate or service this Excavator until you have first read and understood all of the applicable Safety Instructions that are set forth in this Manual.**

**The failure to comply with all relevant Safety Instructions could result in bodily injury.**

## 7. Basic Precautions

**⚠ WARNING** These instructions should be strictly followed for the safety of you, others and your machine.

### Follow safety rules at your workplace

- The operation and servicing of this machine is restricted to qualified persons.
- When operating or servicing the machine, follow all the safety rules, precautions and procedures.
- Any work performed by a team or with a signal person should be conducted in accordance with signals agreed on beforehand.

### Install safety devices

- Make sure that all guards and covers are installed in their correct position. If any of them are damaged, repair them immediately.
- The proper use of all safety devices, such as lock lever, should be well understood by the machine operator.
- Never remove the safety devices. Always make sure that they operate properly.  
**For lock lever, refer to Section "13-15. Parking the machine".**
- Incorrect operation of the safety devices could cause serious bodily injury.

### Wear proper clothing and safety items

- Do not wear loose clothing or jewelry that can be caught on the control levers and other machine parts. Also avoid wearing working clothes stained with oil as they can ignite.
  - Be sure to wear a helmet, safety goggles, safety shoes, a mask, gloves and other protective items, as appropriate.
- Take particular precautions when generating metal debris, when striking metal objects with a hammer or when cleaning components with compressed air.

Also make sure there are no persons near the machine.

**For driving the pins, refer to Section "13-14. Replacing the bucket".**

**For cleaning the elements, refer to Section "25-2. Nonperiodic services".**



### Alcohol

- Never operate the machine while you are under the influence of alcohol or when you are ill or feel unwell as this results in accidents.

**Avoid unauthorized modifications**

- Modifications not recommended by YANMAR may cause safety hazards.
- When you wish to modify your machine, contact your dealer. The implementation of unauthorized modifications or the use of unauthorized attachments could result in bodily injury, since those actions would also violate the terms of YANMAR's Warranty, it would be voided

**Always lock up your machine when leaving the operator's seat**

- When leaving the operator's seat, be sure to place the lock lever in the lock position, to prevent accidental machine movement which could result in bodily injury.
- When you leave the machine:
  - (1) Lower the bucket to the ground.
  - (2) Place the lock lever in the lock position.
  - (3) Stop the engine.
  - (4) Set all the locks in to the lock position.
  - (5) Be sure to take the key out of the starter switch.

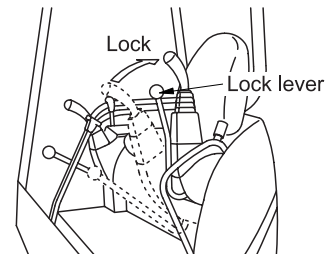

(Left side)

**For information on parking the machine, refer to Section "13-15. Parking the machine".**

**Use handrails and steps when getting on and off**

- Do not jump on or off the machine. Never get on or off a machine in motion as it may result in bodily injury.
  - When getting on and off the machine, face the machine and use the handrails and steps.
  - Do not use control levers as handrails.
  - Make sure that you maintain three point contact with the handrails or the steps.
  - If the handrails and the steps are soiled with oil or dirt, clean them off immediately.
- Repair any damaged parts and retighten any loose bolts.

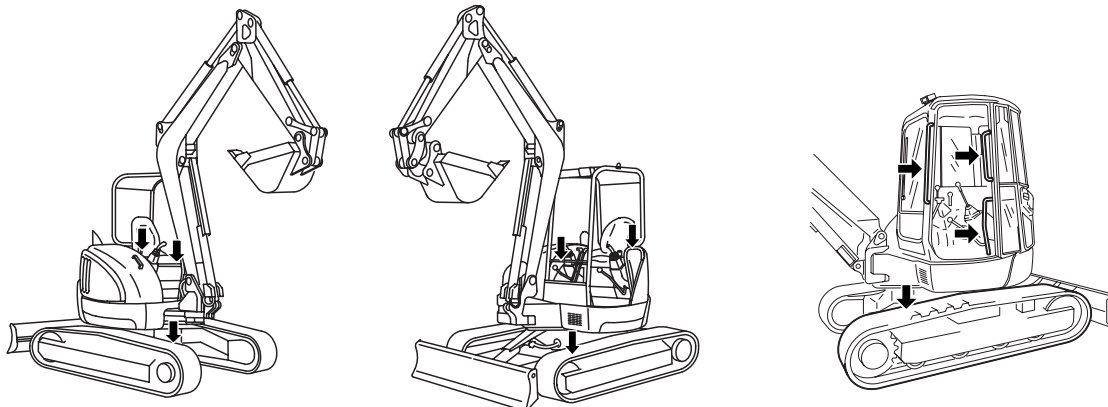

**Keep fuel and oil away from sources of ignition**

- Open flames can ignite fuel, oil, hydraulic oil or antifreeze solutions, which are flammable and dangerous. Special attention must be paid to the following matters.
  - Keep flammable materials away from lighted cigarettes or matches, or any other sources of ignition.
  - Never refuel while the engine is running. Smoking during refueling must be strictly prohibited.
  - Firmly tighten the caps on the fuel and oil tanks.
  - Store fuel and oil in a cool and well-ventilated place where they are not subjected to direct sunlight.
  - Fuel and oil must be stored in a place which meets all applicable safety regulations. Unauthorized persons should not be allowed entry.

**Avoid removing filler caps while temperatures are high**

- The engine coolant, engine oil and hydraulic oil are hot and under pressure immediately after the machine stops operation. Removing caps, draining coolant or oil, or replacing a filter at such a time may cause burns. Allow temperatures to cool down and follow the procedures in this manual.
- When removing the radiator cap, stop the engine and allow the coolant to cool down, then turn the cap slowly to relieve all pressures.
- Before removing the cap from the hydraulic oil tank, stop the engine and turn the cap slowly to relieve all pressure to prevent oil from spouting out.

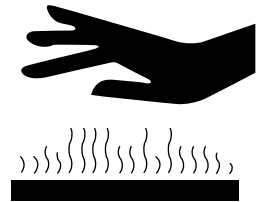
**Avoid harmful asbestos dust**

- Air containing asbestos dust is carcinogenic and is hazardous to humans. Inhalation of the air may cause lung cancer. When handling materials that may contain asbestos, keep in mind that:
  - Compressed air must not be used for cleaning.
  - Water must be used to clean the machine to prevent asbestos from scattering in the air.
  - You must work on the windward side when operating the machine in a place where there may be asbestos dust.
  - You should wear breathing apparatus as necessary.



**Prevent crush injuries by the implements**

- Keep hands, arms and all other parts of your body away from all the moving parts, particularly between the implements and the machine and between the hydraulic cylinder and the implements, as pinch points are created in those areas.



**Keep a fire extinguisher and first aid kit handy**

- The workplace must be provided with a fire extinguisher. Read instructions on the label to familiarize yourself with how to use it.
- Keep a first aid kit in a prescribed place.
- Advise what to do in the event of fire or accidents.
- Indicate who to contact in an emergency and keep their telephone number in a prominent place.

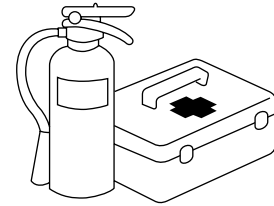

**Precautions for installing optional parts and attachments**

- When installing or using optional attachments, read the operating instructions for the attachments and the Manual Sections relating to the installation of attachments.
- Use only attachments authorized by YANMAR. The use of unauthorized attachments may affect not only the safety of the machine but also the proper operation and life of the machine.
- The use of unauthorized attachments would also violate the terms of YANMAR's Warranty, so that it would be voided.

**Caution for cabin glass**

- If the glass of the cabin should be broken by accident, it is very dangerous since the operator's body might contact the implement directly. Immediately stop working to replace the broken glass with a new one.

## 8. Operating Precautions

**⚠ WARNING** These instructions should be strictly followed for the safety of you, others and your machine.

### 8-1. Precautions before starting the engine

#### Ensure the safety of your workplace

- Before starting the machine, check to see if there are any hazards in your working area.
- Examine the terrain and soil, and decide the best way to do the work.
- When working on the street, provide a signal person or fence for the safety of vehicles and pedestrians.
- If there are underground utilities at the work site, such as water pipes, gas pipes, high-voltage conduits or others, contact the responsible companies to locate them exactly, so as not to damage them.
- Before operating the machine in water, or crossing a creek, confirm the condition of the submerged ground, the water depth and the water flow speed, and make sure that the depth is within the allowable level.

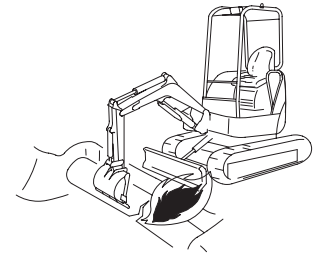

**For allowable water depth, refer to Section "13-10. Precautions for working".**

#### Prevent fire

- Wood chips, dead leaves, trash and other flammable materials in proximity to the engine are hazardous as they may cause fire. Always check and keep your machine clear of these flammable materials.
  - Check for any leaks from fuel, lube oil or hydraulic oil lines. Repair faults and clean spilled oil as necessary.
- For additional information, refer to Section "13-1. Checking before starting the engine".**
- Check to see where fire extinguishers are located and know how to use them.



#### Inspect around the operator's seat

- Dirt, oil and snow on the floor, levers, handrails or steps are slippery and hazardous. Remove them all completely.
- Keep parts and tools away from the operator's seat as they may damage the control levers or switches or create any other hazards.

**Provide adequate ventilation when working in an enclosed area**

Engine exhaust fumes are harmful to the human body and their inhalation is extremely hazardous. When starting the engine in an enclosed area, open the windows and doors for ventilation. Also do not idle the engine unnecessarily or leave the engine running while the machine is not in use.



**Keep the cabin window clean**

- Keep the surface of the cabin windows and the headlights clean for clear view.
- Make sure that your machine is equipped with headlights and all required working lamps, and that they work properly.

**Fasten the seatbelt**

- For your safety, ROPS (Roll-Over Protective Structure)/FOPS (Falling Objects Protective Structures) with a seatbelt is installed.
- Always fasten the seatbelt across the pelvic region and adjust snugly before you operate the machine.  
Never fasten a seatbelt across the abdomen.
- The seatbelt must be replaced after an accident.
- In addition the seat and seat mounting must be checked by your dealer after an accident has occurred.
- If the seat and seat mounting are damaged, they must be replaced.

**ROPS/FOPS**

- Never modify the structural member of ROPS/FOPS.
- If ROPS/FOPS is damaged, replace it immediately to prevent bodily injury.  
Never repair or modify it.

**Caution for the protection of plants from hot wind**

The hot wind of the high temperature is exhausted from the muffler and the radiator. If this hot wind hits plants directly, they will die. Give a cover board to protect plants from the hot wind when working near the arranging fence or plant.



**Suggest:**

**For more complete manuals. Please go to the home page.**

**<https://www.ebooklibonline.com>**

**If the above button click is invalid. Please download this document first, and then click the above link to download the complete manual.**

**Thank you so much for reading**

**8-2. Precautions for starting the engine, working and parking**

**Signal before starting the engine**

- Check the machine carefully before initial start up for the day.
- Make sure there are no persons near the machine before getting on it.
- Never start the engine when the "SERVICING IN PROGRESS" tag is attached to the control system.
- Sound the horn to alert people nearby before starting the engine.
- Be sure to start the engine and operate the machine from the operator's seat only.
- Do not allow any other persons to get on the machine.

**Check the position of the blade before operating the machine**

- Check the position of the blade before operating the travel levers. When the blade is located in the back, the operation of the travel levers is reversed.

**For instructions on How the machine travels, refer to Section "13-4. Traveling".**

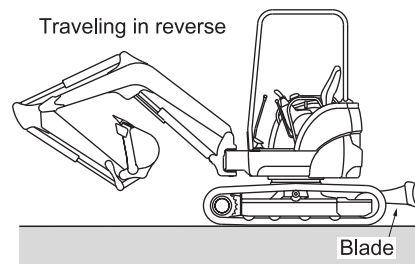

**Make sure there are no persons nearby when turning or reversing the machine**

- A signal person should be provided for safety when the work site is hazardous or when visibility is poor.
- Keep all other persons away from the work site or the traveling path of the machine.
- Alert persons nearby with a horn or other signal before starting the machine.
- The machine permits a limited range of vision toward the rear. Make sure there are no persons behind the machine before reversing.

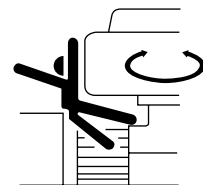
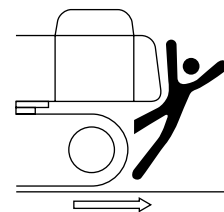

**Precautions for traveling**

- When traveling with the machine, keep the bucket 15.75 to 19.69 in. (40 to 50 cm) above the ground with boom and arm folded as illustrated below.
- If you need to operate the control levers while traveling, never move them abruptly.
- Travel the machine at a low speed and slow down when turning on rough terrain.
- Avoid running over obstacles if possible. If unavoidable, run the machine at a low speed while keeping the implement close to the ground. Never run over obstacles that may cause the machine to tilt more than 10 degrees.

Orientation in travel

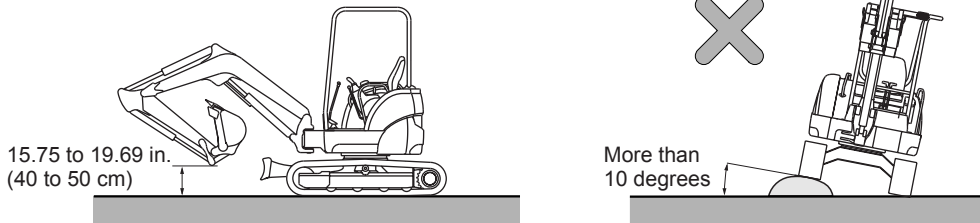

**Running the machine on a slope**

- Run the machine carefully on a slope to avoid overturning or skidding sideways.
  - When running the machine on a slope, keep the bucket 7.87 to 11.8 in. (20 to 30) cm above the ground so that you can immediately lower it to the ground and stop the machine in an emergency.
  - Never turn the machine on a slope or run it across the slope. Move down to flat ground and then make a turn.
- For instructions on how to run the machine on a slope, refer to Section "13-11. Precautions for going up and down a slope".**
- On grasses, dead leaves or a wet metal plate, even with a slight gradient, the machine will easily slip. Under those circumstances, run the machine carefully at low speed to prevent it from skidding.

Going down a slope

Going up a slope

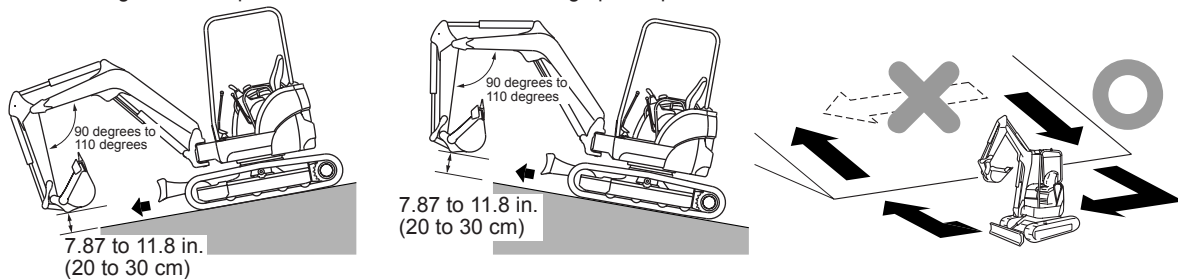

**<https://www.ebooklibonline.com>**

Hello dear friend!

Thank you very much for reading.

Enter the link into your browser.

The full manual is available for immediate download.

**<https://www.ebooklibonline.com>**