

YANMAR

SERVICE MANUAL

MARINE DIESEL ENGINE

MODEL 6CX-ETE

CONTENTS

1. Specifications	1
1-1. Major Specification	1
1-2. Marine Gear	2
2. Disassembly and Reassembly	3
2-1. Preparations before Disassembly and Reassembly	3
2-2. Disassembly and Reassembly Tools	4
2-3. Reassembly Procedures	9
3. Inspection and Servicing of Major Engine Parts	32
3-1. Cylinder Head	32
3-2. Piston and Piston Pin	37
3-3. Connecting Rod	41
3-4. Cylinder Sleeve	42
3-5. Cylinder Block	44
3-6. Crankshaft and Main Bearing	44
3-7. Camshaft and Valve Gear	49
3-8. Timing Gear	51
3-9. Lube Oil System	52
3-10. Cooling Water System	56
3-11. Fuel Oil System	60
3-12. Piping Diagram	75
3-13. Electrical Equipment	79
3-14. Reduction Reversing Gears	93
3-15. Turbocharger	104
3-16. Front Driving Equipment	109
4. Periodic Inspection	110
5. Service Standard	112
6. Adjustment and Set Values	114
7. Tightening Torque of Major Bolts and Nuts	115

<https://www.ebooklibonline.com>

Hello dear friend!

Thank you very much for reading.

Enter the link into your browser.

The full manual is available for immediate download.

<https://www.ebooklibonline.com>

1. Specifications

1-1. Major Specification

(Without marine gear)

ENGINE MODEL		UNIT	6CX-ETE				
Type			Vertical, water-cooling, 4-cycle diesel engine				
Combustion system			Direct injection				
Aspiration			Turbocharger with air cooler				
No. of cyl. - bore × Stroke		mm	6 - 110 × 125				
Displacement		ℓ	7.127				
Continuous rating	Output/Crankshaft speed		HP/rpm	375/2600			
	Brake mean effective pressure		kgf/cm ²	18.21			
	Piston speed		m/sec	10.83			
Max. rating	Specifications			Flywheel end			
	Output/Crankshaft speed		HP/rpm	420/2700			
	Brake mean effective pressure		kgf/cm ²	19.64			
	Piston speed		m/sec	11.25			
Non-load rotation speed (Max./Min)		rpm	3000 ± 25 / 700 ± 25				
Starting system			Electric starting, 12V-4KW				
Firing order			1-4-2-6-3-5-1				
Direction of rotation (viewed from stem)	Crankshaft			Counter-clockwise			
	Propeller shaft			Bi-rotation			
Lub. oil capacity	Max.		ℓ	23			
	Effect		ℓ	12			
Marine gear	Model			YX-70S			
	Type			Hydraulic wet multi-disk type			
	Reduction ratio (forward)			1.52	1.96	2.50	
	Propeller shaft speed (at cont. rating)		rpm	1716	1324	1040	
	Direction of rotation (propeller shaft)			Clockwise or counterclockwise viewed from stem			
	Dry weight		kg	160			
	Lubricating oil capacity	Max.		ℓ	5		
		Effective		ℓ	0.7		
Hydraulic oil pressure		kgf/cm ²	24 ± 5				
Fuel system	Fuel injection pump			In-line type			
	Injection timing			b.T.D.C 12 ± 1			
	Type of injection nozzle degree			Hole type 5 - φ 0.34 × 150°			
	Injection pressure		kgf/cm ²	240 ± 5			
	Applicable fuel			Diesel oil or light oil (Cetane value ≥ 45)			
	Fuel filter			Paper element			
Engine lub. oil system	Lubrication			Forced lubrication by geared pump			
	Lub. oil discharge volume		ℓ/hr./rpm	≥ 6720/2600			
	Lub. oil pressure		kgf/cm ²	5 ± 0.5			
	Lub. oil			API Service grade CD			
	Lub. oil filter			(Suction side) Perforated steel plate	(Discharge side) Paper element		
Cooling water system	Sea water pump			Rubber impeller type, gear driving type			
	Freshwater pump			Center type, V-belt driving type			
	Cooling			Fresh water cooling			
	Pump discharge volume		ℓ/hr./rpm	Seawater : ≥ 9820/2600 Fresh water : ≥ 13000/2600			
	Fresh water capacity inside engine		ℓ	36			
	Fresh water capacity in sub-tank		ℓ	1.1			
Turbocharger	Type			Garret TW51			
	Cooling			Water cooling			
	Lubrication			Common with engine			
Air cooler	Type and capacity			Fin tube type 6.5m ²			
	Cooling			Seawater cooling			
Engine dimension: Overall length × overall width × overall height		mm	1607 × 869 × 994				
Piston stroke height (from installation floor)			797				
Engine dry weight (inc. clutch)		kg	990				

△ NOTE Max. rating: Continuous operation hours at max. below 0.5 hours.







1-2. Marine Gear

Reduction and reversing gear	Model		YX-70S		
	Type		Constant mesh gear with multiple disc clutch		
	Reduction ratio(Ahead/Astern)		1.52/1.52	1.96/1.96	2.50/2.50
	Propeller speed(Ahead)(at continuous rating)	rpm	1716/1716	1324/1324	1040/1040
Direction of rotation	Crankshaft		Counterclockwise viewed from stern		
	Propeller shaft		Changeable(Clockwise/conter-clockwise)		
Hydraulic oil pressure			24kg/cm ² ±0.5/2700rpm		
Lube oil pressure			2.5kg/cm ² ±0.5/2700rpm		
API Service grade			CD		
Dry weight		kg	210		

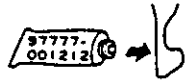
2. Disassembly and Reassembly

2-1. Preparations before Disassembly and Reassembly

2-1-1 Visual Mark List for Disassembly and Reassembly

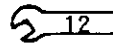
Visual Mark		Visual Mark	
	See		※1 Apply liquid packing
	Caution		Safety
	Measure		Clean
	Oil supply		※2 Use torque wrench

※1 THREE BOND 3B-388-055

※2 The figure shows the widths across flat of the hexagonal part.

2-1-2 Disassembly

- (1) Prepare the disassembly tools, measuring devices and record forms.
- (2) Prepare the cleaning machine and cleaning cans.
- (3) Prepare a place for putting parts and parts containers.
- (4) Extract cooling water and lube oil.
- (5) Put the disassembled parts in order.
- (6) Return bolts and nuts to their original positions temporarily to avoid confusion with different bolt and nut types.
- (7) Locate the cause of trouble accurately before disassembly, and do not remove or disassemble unnecessary parts.

2-1-3 Reassembly

- (1) Clean and inspect the disassembled parts completely.
- (2) Apply clean engine oil to the sliding and rotational parts before installation.
- (3) Replace all gaskets and O-rings.
- (4) Apply liquid packing to the necessary parts to prevent water or oil leakage.
- (5) Check and ensure the correct oil and thrust clearance during reassembly.
- (6) Install the parts according to the alignment marks when they are provided. Take care of the combination of the parts with selective engagement.
- (7) Do not mix up bolts, nuts and washers. Tighten the major bolts and nuts to the specified tightening torque. Take special care when tightening aluminum alloy parts.
- (8) Apply engine oil to the threads and seat of the major bolts and tighten them to the specified tightening torque.

2-2. Disassembly and Reassembly Tools

Standard tools

The following are the standard disassembly and reassembly tools:

Name of tool	Size	Shape
Double-headed wrench	8 × 10, 12 × 14, 13 × 17 19 × 22, 24 × 27	(for removing fuel valve)
Wrench	7, 26	
Monkey wrench	200	
Screw driver	⊕, ⊖ changeable	
Hexagon bar wrench	(for clutch emergency bolt)	
Double-head wrench	17 × 19	
Pliers		
Box wrench	19 × 12 (for cyl. head) 13 × 17 (for fuel oil pump)	
Extractor	(for fuel valve adiabatic packing) 127610-92910	
Extractor	(for removing fuel valve) 127616-92500	
Clearance gauge	(for adjusting intake/exhaust valve clearance	
Hammar		
Filter wrench	(for removing filters) 127610-92750	
Oiler		
Turning handle		

Tools (to be specially ordered)

Name of tool	Code No.	Shape
Socket (for rod bolt)	127610-92730	
Extractor for valve guide	127411-92160	
Extractor for fuel oil valve	127616-92500	
Piston insertion tool	122310-92140	
Piston rings fitting/removal tool	135410-92140	
Oil pan potitioning tool	1. Bolt (4pcs) 127610-92700 2. Spacers A 127610-92680 3. Spacers B 127610-92690	

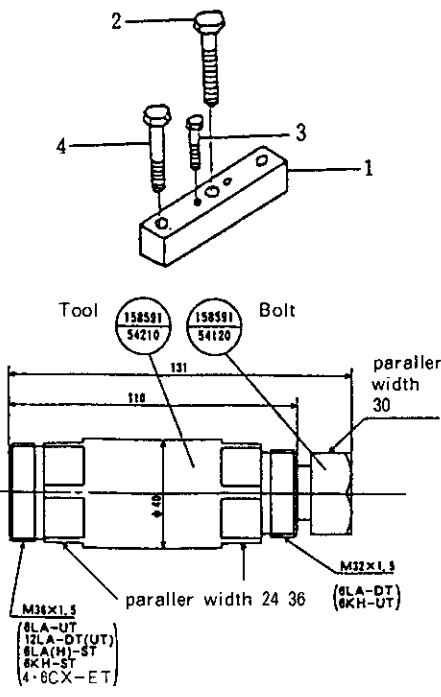
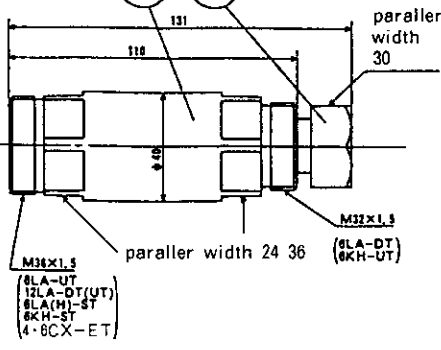
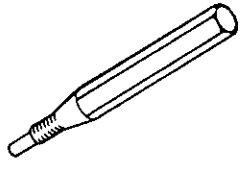
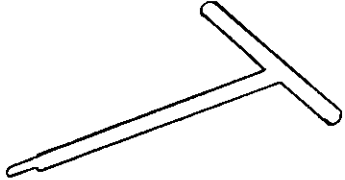
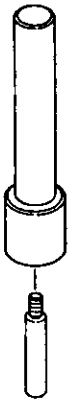
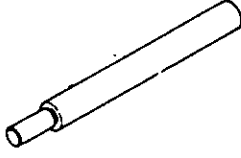
Name of tool	Code No.	shape
Fresh water pump impeller (cam gear puller) (Press-fitting type)	1. Spacer 127610-92430 2. Bolt 124160-77511 3. Bolt (for impeller) × 2 26116-060302 4. Bolt (for cam gear) × 2 26116-080502	
Automatic timer tool (adiabatic material puller)	158591-54120 158591-54200	
Adiabatic material puller	127610-92910 (Standard)	
Protector pulier	127695-92910	
Stem seal insertion tool		
Valve guide puller		

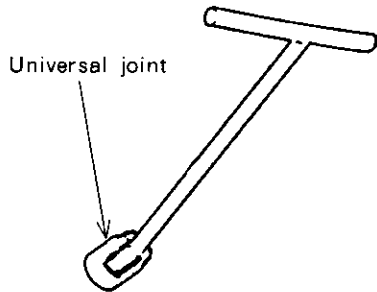
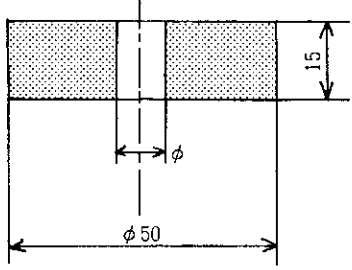
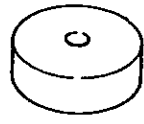
Name of tool	Code No.	shape
Exhaust manifold puller		
Fuel valve puller tool 127616-92500		

Special tools for clutch

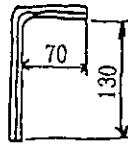
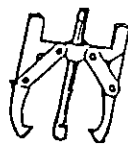
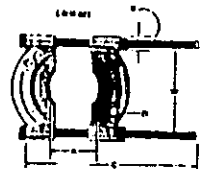
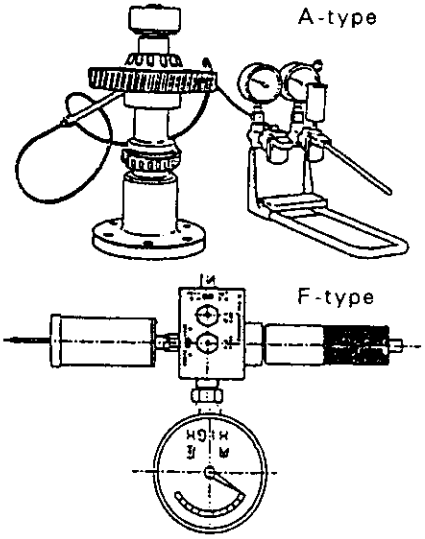
No.	Name of tool	Note	shape
1	Emergency bolt span	For tightening the emergency bolt on clutch failure	
2	Gear puller		
3	Bearing separator	For removing bearing; used together with the gear puller	
4	Hydraulic fitting tool	For disassembly of output shaft joint Output shaft joint and large gear	





Name		for using																				
Liquid packing (THREEBOND auxiliary packing):		<p>The silver grey semi-dry type viscoelastic liquid packing based on extreme heat-resisting synthetic rubber and synthetic resin. Apply the packing to the seal surface and join the part after several minutes when the packing has become semi-dry.</p> <p>The white liquid packing based on nylon resin. Brush the packing on the seal surface and join the part after several minutes when the packing has become semi-dry.</p> <p>Be sure to stir well before use.</p>																				
White paint		Coat the paint on the contact area with the cylinder body before inserting the cylinder liner to prevent rust and water leakage. (Use the oil type make-up paint.)																				
Name		quantity	Code No.	Note																		
Scale removing agent	UNICON	1 case (4kg × 4)	974100-01460	<p>The strong scaling agent removes scale quickly (1-10 hrs.).</p> <p>Dissolve the agent in 10 parts of water or seawater (by weight ratio) and stir it well.</p> <p>Scale can be removed by just immersing the disassembled parts. To speed up the treatment, stir the solution. When the cleaning performance drops, neutralize the solution and throw it away.</p>																		
	Counteragent (caustic soda)	1 case (2kg × 4)	974100-0200																			
	PH test paper		974100-04200																			
Anti-rust agent		21	974100-04200	Mix the agent in ten parts of fresh water and stir the solution by operating the engine for about 5 minutes. The anti-rust performance lasts for about 6 months.																		
Yanmar Super Freeze				<p>Can be used both as anti-freeze in winter and coolant in summer. The performance lasts for 2 years.</p> <p>The Super Freeze can safely be mixed with anti-rust agent.</p>																		
		<table border="1"> <tbody> <tr> <td>Temp.</td> <td>-5°C</td> <td>-10°C</td> <td>-15°C</td> <td>-20°C</td> <td>-25°C</td> <td>-30°C</td> <td>-35°C</td> <td>-40°C</td> </tr> <tr> <td>Volume ratio</td> <td>15%</td> <td>25%</td> <td>30%</td> <td>35%</td> <td>40%</td> <td>45%</td> <td>50%</td> <td>55%</td> </tr> </tbody> </table>			Temp.	-5°C	-10°C	-15°C	-20°C	-25°C	-30°C	-35°C	-40°C	Volume ratio	15%	25%	30%	35%	40%	45%	50%	55%
Temp.	-5°C	-10°C	-15°C	-20°C	-25°C	-30°C	-35°C	-40°C														
Volume ratio	15%	25%	30%	35%	40%	45%	50%	55%														





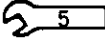
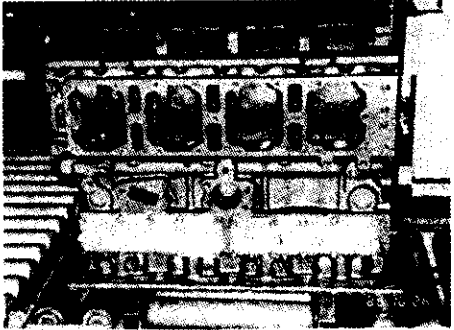

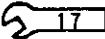
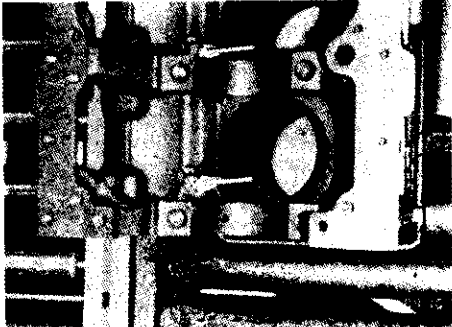
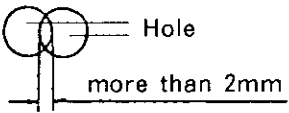
Name	quantity	Code No.	using
Metal Clean Y (cleaning agent)	1kg × 20	975600-02000	<p>Has strong performance to remove accumulated carbon.</p> <p>Can safely be heated to double the cleaning performance.</p> <p>Corrodes almost no metals, including iron. (Also has anti-rust effect.)</p> <p>To use, dissolve 1kg of the agent in 40 liters of water.</p> <p>When a cleaning machine is used, use 4-6% solution and heat in to 60-80°C.</p> <p>This will further raise the effect.</p>
Blower Clean (Special cleaning agent for turbocharger)	4 ℓ × 4	919200-10000	Special cleaning agent for turbocharger blower. Needs on water washing.
	18 ℓ × 1	919200-30000	
	1500cc × 6	919200-20000	

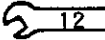
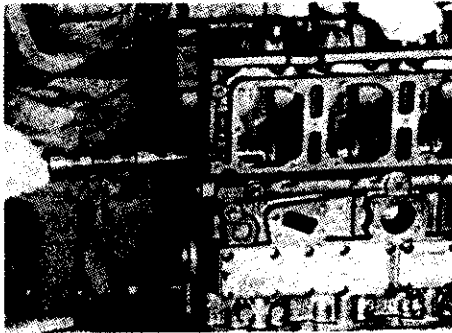
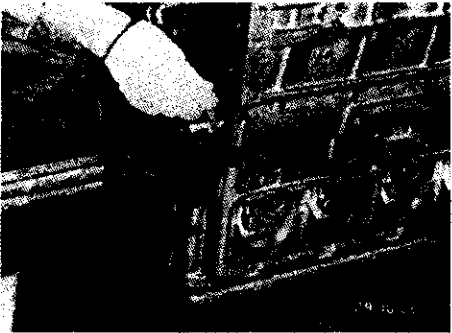
Measuring Device

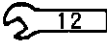
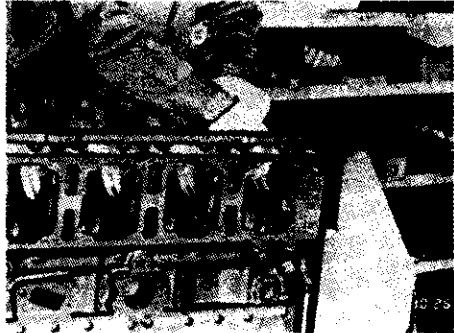
Name	quantity	Code No.	using
Cap tester	RCT-2A	955000-055000	For testing the radiator and the cap.

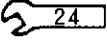
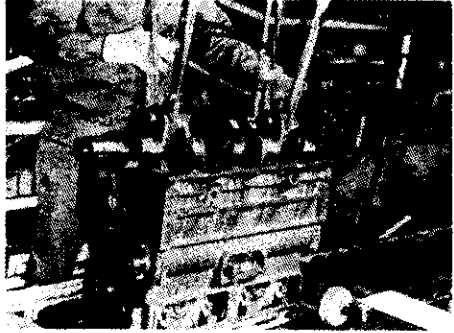
2-3. Reassembly Procedures

No.	Item	Procedure	Tool & Caution	Illustration				
1	Cylinder Block	<p>Clean the bearing holes completely. Reverse the cylinder block before reassembly.</p> <table border="1" data-bbox="416 427 756 524"> <tr> <td>T-plug 1/8 tightening torque</td> <td>0.5kgf - m</td> </tr> </table>	T-plug 1/8 tightening torque	0.5kgf - m		 <p>Cylinder Block</p>		
T-plug 1/8 tightening torque	0.5kgf - m							
2	Piston Cooling Nozzle	<p>Install the nozzle correctly according to the positioning pin. Take care not to over-tighten the nozzle.</p> <table border="1" data-bbox="416 808 756 869"> <tr> <td>Tightening torque</td> <td>2.0kgf-m</td> </tr> </table> <p>Check carefully that there are no chips or dust in the oil holes of the nozzle body, nozzle installation hole and check nozzle. Check that the nozzle body does not touch the cylinder block.</p>	Tightening torque	2.0kgf-m	 	 <p>Piston Cooling Nozzle</p>		
Tightening torque	2.0kgf-m							
3	Cam Shaft	<p>Apply lube oil to the cam shaft journal. Insert the cam shaft. Install the thrust plate.</p> <table border="1" data-bbox="416 1267 756 1328"> <tr> <td>Tightening torque</td> <td>2.6 ± 0.2 kgf-m</td> </tr> </table> <p>Measure the side clearance.</p> <table border="1" data-bbox="416 1402 756 1503"> <tr> <td>Side clearance</td> <td>0.10-0.25mm</td> </tr> </table> <p>Installation of cam shaft metal. Replace the cam shaft metal as follows:</p> <ol style="list-style-type: none"> 1. Apply lube oil to the outside circumference of the cam shaft metal and the inside bore of the block. 2. Align the oil hole so that the joint of the winding metal comes to the upper side. 3. Overlapping of not less than 2mm will suffice for the alignment of the oil holes of the block and cam shaft metal. (Check the alignment after knocking in the cam shaft metal.) 	Tightening torque	2.6 ± 0.2 kgf-m	Side clearance	0.10-0.25mm	 	 <p>Cam Shaft</p>  <p>Installation of the thrust metal</p>
Tightening torque	2.6 ± 0.2 kgf-m							
Side clearance	0.10-0.25mm							

No.	Item	Procedure	Tool & Caution	Illustration						
4	Cooling Water Passage Cover	Install the cooling water passage cover.	 12							
5	Crankshaft and Main Bearing	<p>The upper bearing (block side) has an oil groove; no oil groove in the lower bearing. The standard bearing is at the flywheel side (with flange). Apply lube oil to the crank and assemble. Confirm the alignment number on the bearing cap and block. Assemble with the F-mark at the flywheel side. Apply lube oil to the bolt threads and seat face and tighten the bolt to the specified tightening torque. Turn manually to check that it turns lightly. Measure the side clearance.</p> <table border="1" data-bbox="395 846 794 1070"> <tr> <td>Cap bolt tightening torque</td> <td>$28^{+1.0}$ kgf-m</td> </tr> <tr> <td>Side clearance</td> <td>0.155 - 0.296mm</td> </tr> <tr> <td>Crankshaft bearing oil clearance</td> <td>0.04 - 0.108mm</td> </tr> </table>	Cap bolt tightening torque	$28^{+1.0}$ kgf-m	Side clearance	0.155 - 0.296mm	Crankshaft bearing oil clearance	0.04 - 0.108mm	  24	<p>Fitting the upper bearing</p>  <p>Fitting the crank shaft</p>  <p>Apply lube oil</p>  <p>Fitting the bearing cap</p>  <p>Fitting the cap bolt</p>  <p>Measure the side clearance</p>
Cap bolt tightening torque	$28^{+1.0}$ kgf-m									
Side clearance	0.155 - 0.296mm									
Crankshaft bearing oil clearance	0.04 - 0.108mm									



Suggest:







For more complete manuals. Please go to the home page.

<https://www.ebooklibonline.com>

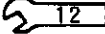
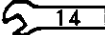
If the above button click is invalid. Please download this document first, and then click the above link to download the complete manual.

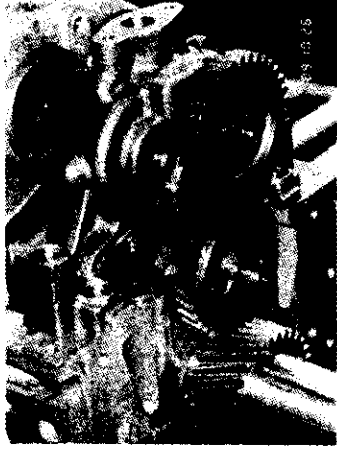
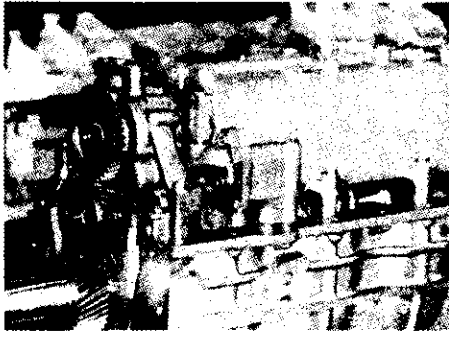
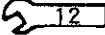
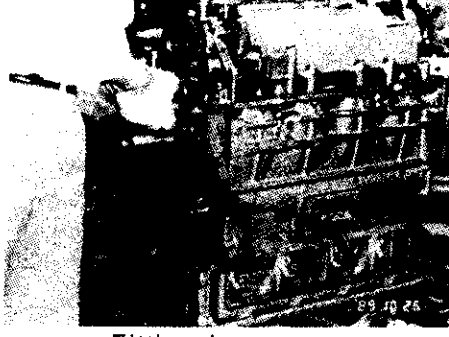
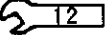
Thank you so much for reading

No.	Item	Procedure	Tool & Caution	Illustration						
6	Idle Gear (Lube Oil Pump)	<p>Check the gear side clearance.</p> <table border="1" data-bbox="408 331 762 430"> <tr> <td data-bbox="408 331 560 430">Gear side clearance</td> <td data-bbox="560 331 762 430">0.066–0.114mm</td> </tr> </table> <p>Check the gear backlash.</p> <table border="1" data-bbox="408 488 762 586"> <tr> <td data-bbox="408 488 560 586">Gear backlash</td> <td data-bbox="560 488 762 586">0.08–0.16mm</td> </tr> </table> <p>Install the idle gear to the cap.</p> <table border="1" data-bbox="408 645 762 703"> <tr> <td data-bbox="408 645 560 703">Tightening torque</td> <td data-bbox="560 645 762 703">1.5–2.0kgf-m</td> </tr> </table>	Gear side clearance	0.066–0.114mm	Gear backlash	0.08–0.16mm	Tightening torque	1.5–2.0kgf-m		 <p data-bbox="1098 667 1315 694">Fitting the idle gear</p>
Gear side clearance	0.066–0.114mm									
Gear backlash	0.08–0.16mm									
Tightening torque	1.5–2.0kgf-m									

No.	Item	Procedure	Tool & Caution	Illustration						
7	Lube Oil Pump	<p>Install the lube oil assembly. Install the suction and discharge pipes.</p> <table border="1" data-bbox="386 338 802 439"> <tr> <td>(Bolt head width 12) Tightening torque</td> <td>2.5 ± 0.2 kgf-m</td> </tr> </table> <p>Check the gear backlash (to the crankshaft).</p> <table border="1" data-bbox="386 495 802 595"> <tr> <td>Backlash for crank gear</td> <td>0.12-0.22mm</td> </tr> </table>  <p>Fitting to the suction pipe</p>	(Bolt head width 12) Tightening torque	2.5 ± 0.2 kgf-m	Backlash for crank gear	0.12-0.22mm	  	 <p>Fitting to the lube oil pump</p>  <p>Fitting to the Safety valve and discharger pipe</p>		
(Bolt head width 12) Tightening torque	2.5 ± 0.2 kgf-m									
Backlash for crank gear	0.12-0.22mm									
8	Gear Case	<p>Install the bolt for fixing the fuel pump and the stud bolt for fixing the seawater pump to the gear case in advance. Match up the mounting surfaces of the oil pan. Align the positioning pin to the block and install the gear case.</p> <table border="1" data-bbox="386 1373 802 1473"> <tr> <td>(Bolt head width 12) Tightening torque</td> <td>2.6 ± 0.2 kgf-m</td> </tr> </table> <p>Cut off the protruding packing.</p>	(Bolt head width 12) Tightening torque	2.6 ± 0.2 kgf-m		 <p>Fitting the gear case</p>				
(Bolt head width 12) Tightening torque	2.6 ± 0.2 kgf-m									
9	Oil Pan	<p>Bring the gear case level so that the packing will not break. (Use the fitting tool.)</p> <table border="1" data-bbox="386 1619 802 1720"> <tr> <td>(Bolt head width 12) Tightening torque</td> <td>2.6 ± 0.2 kgf-m</td> </tr> </table> <p>After tightening, cut off the packing protruding on the wheel housing side.</p> <p><i>Note:</i></p> <table border="1" data-bbox="386 1816 802 1966"> <tr> <td colspan="2"><i>Apply THREEBOND to both sides of the packing at the three-face joint of the gear case and flywheel side. Match up the installation faces of the wheel housing.</i></td> </tr> </table> <table border="1" data-bbox="386 1977 802 2078"> <tr> <td>Step of the joint face at the flywheel housing side</td> <td>0.1mm</td> </tr> </table>	(Bolt head width 12) Tightening torque	2.6 ± 0.2 kgf-m	<i>Apply THREEBOND to both sides of the packing at the three-face joint of the gear case and flywheel side. Match up the installation faces of the wheel housing.</i>		Step of the joint face at the flywheel housing side	0.1mm	  	 <p>Fit the oil pan using the tool</p>
(Bolt head width 12) Tightening torque	2.6 ± 0.2 kgf-m									
<i>Apply THREEBOND to both sides of the packing at the three-face joint of the gear case and flywheel side. Match up the installation faces of the wheel housing.</i>										
Step of the joint face at the flywheel housing side	0.1mm									

<https://www.ebooklibonline.com>

Hello dear friend!

Thank you very much for reading.

Enter the link into your browser.

The full manual is available for immediate download.

<https://www.ebooklibonline.com>