

**omar172611 - 9100, 9200, 9300 and 9400 Tractors (030001-040000)
PTO Driveline**

PTO Driveline

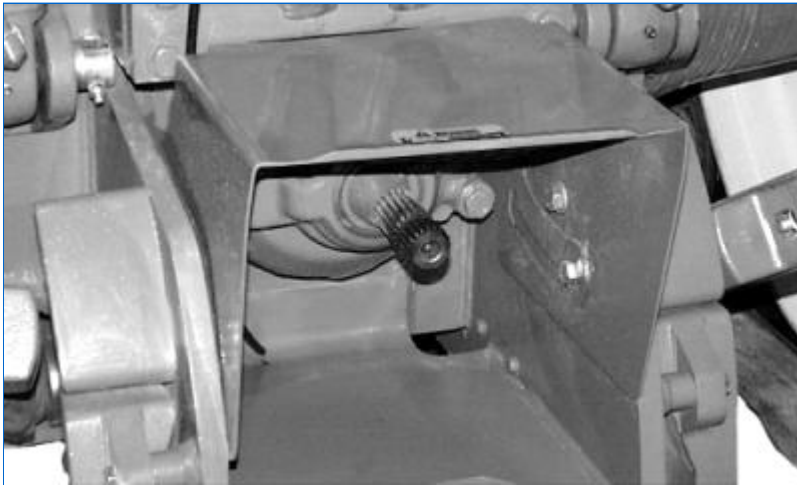

RW26586-UN: PTO Driveline Decal

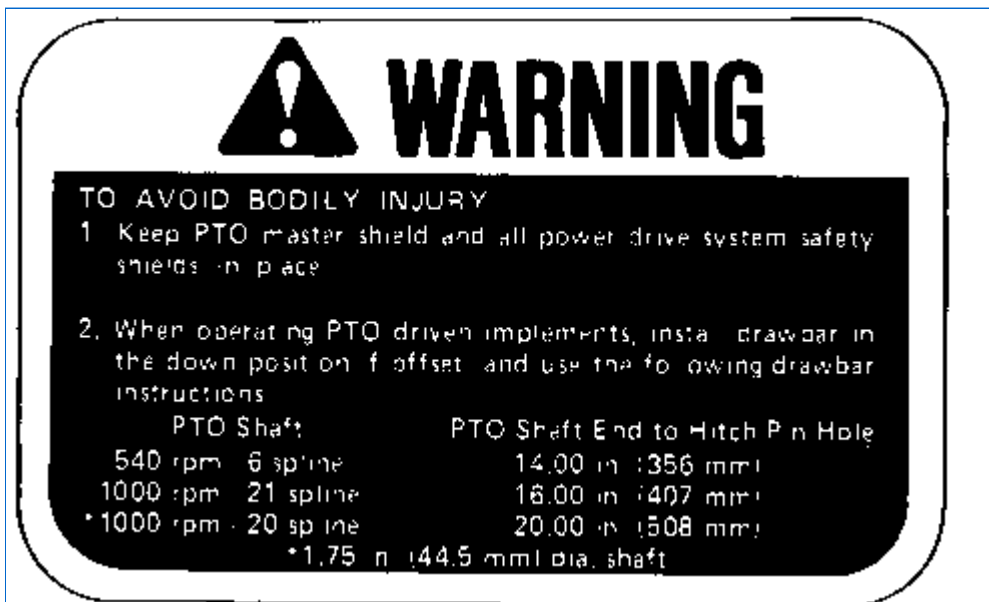

RW10950-19: PTO Driveline Decal

omar172611 - 9100, 9200, 9300 and 9400 Tractors (030001-040000) Couple Implement Securely

Couple Implement Securely



RW26057-UN: Fasten Implement Securely Decal

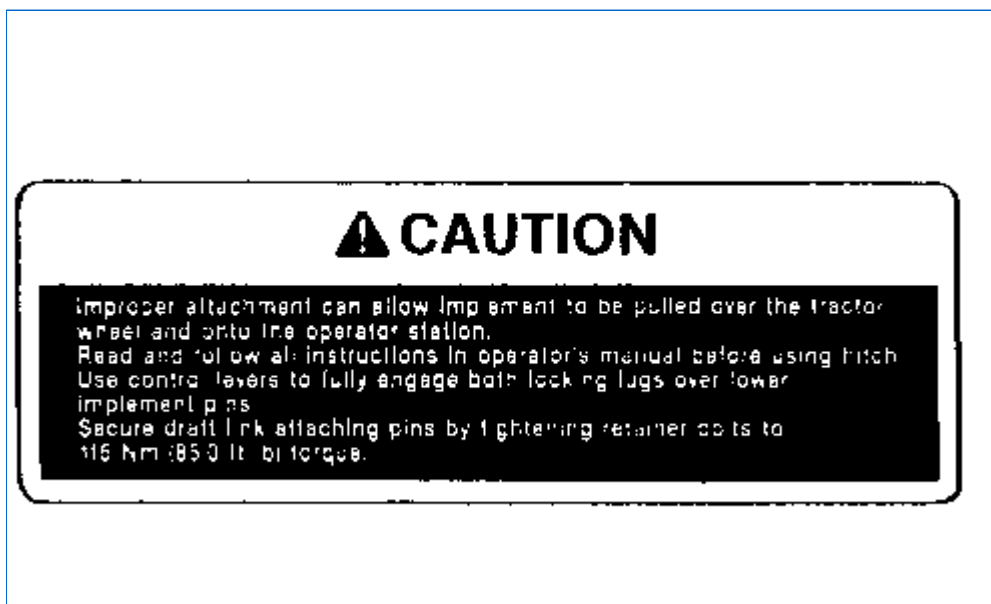

RW55095-19: Fasten Implement Securely Decal

<https://www.ebooklibonline.com>

Hello dear friend!

Thank you very much for reading.

Enter the link into your browser.

The full manual is available for immediate download.

<https://www.ebooklibonline.com>

omar172611 - 9100, 9200, 9300 and 9400 Tractors (030001-040000) Front Console

Front Console

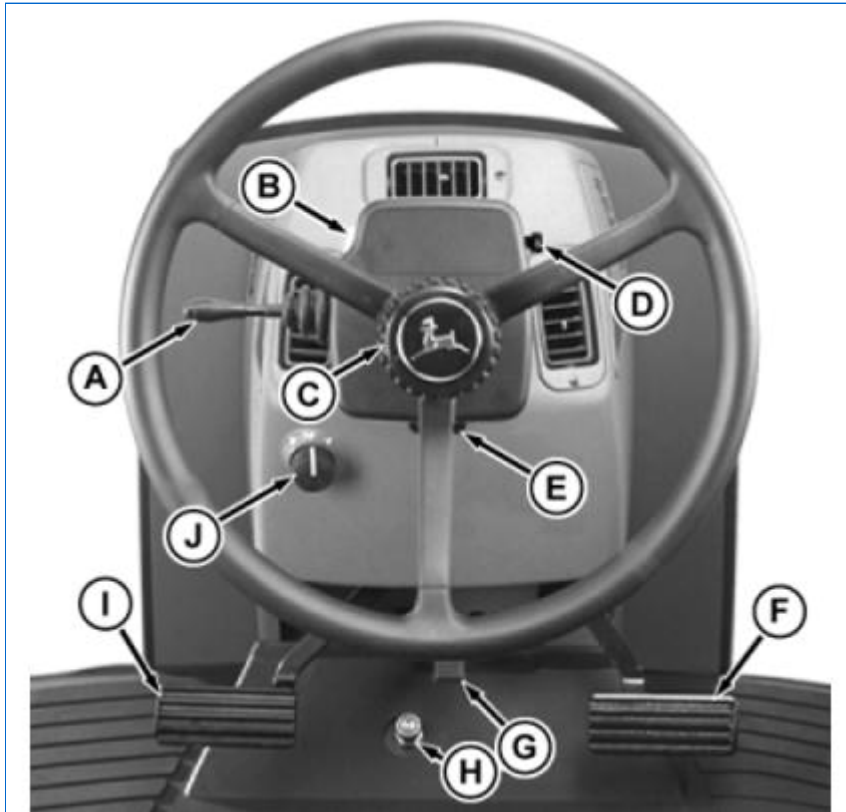

RW26047-UN: Front Console-Controls/Instruments

LEGEND:

- A - Turn Signal Lever, Dimmer Switch, Horn, Flash-to-Pass
- B - Ether Aid Switch
- C - Steering Wheel Telescope Release
- D - Key Switch
- E - Steering Wheel Tilt Release
- F - Brake Pedal
- G - Steering Column Foot Release
- H - Differential Lock
- I - Clutch Pedal
- J - Air Flow Direction Knob

omar172611 - 9100, 9200, 9300 and 9400 Tractors (030001-040000) Shift and PTO Levers

Shift and PTO Levers

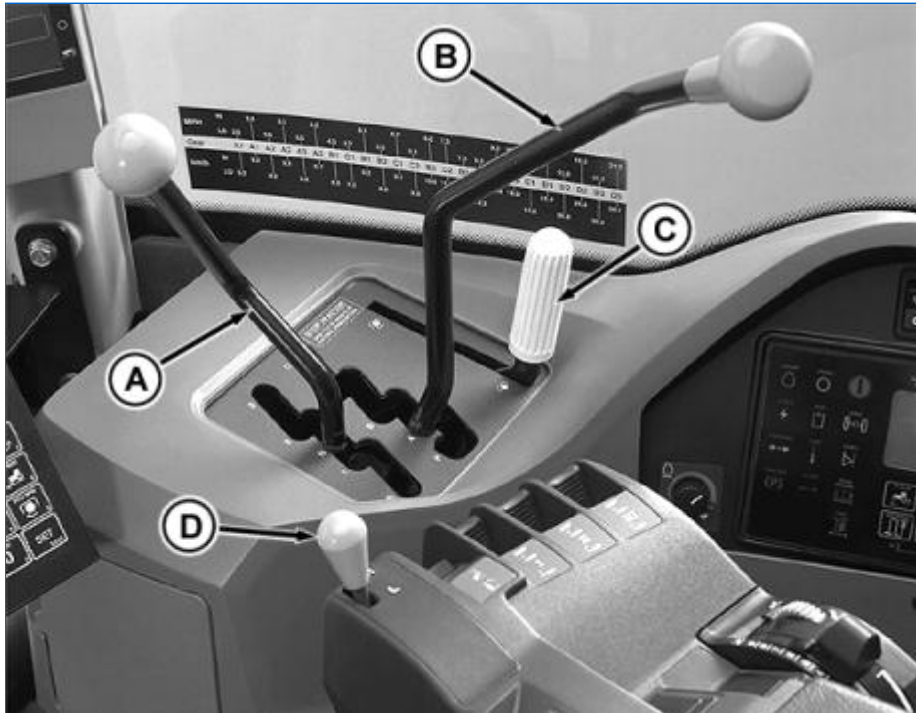

RW26733-UN: Shift and PTO Levers

LEGEND:

- A - Gear-Shift Lever
- B - Range-Shift Lever
- C - PTO Lever (*Optional*)
- D - Hi-Lo Shift Lever

omar172611 - 9100, 9200, 9300 and 9400 Tractors (030001-040000) Armrest Controls

Armrest Controls

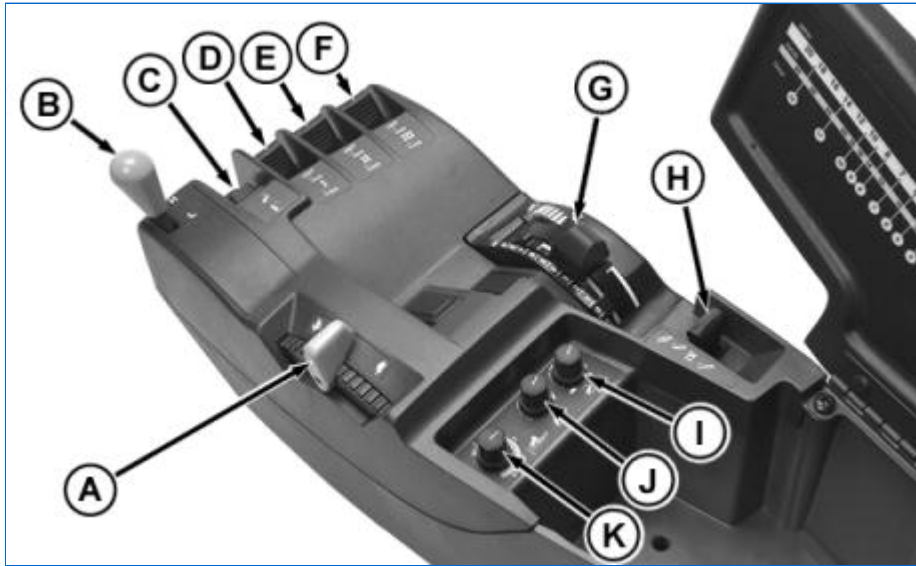

RW26067-UN: Arm Rest Controls

LEGEND:

- A - Hand Throttle
- B - Hi-Lo Shift Lever
- C - Hitch Raise/Lower Switch
- D - Remote Hydraulic Lever (**SCV I**)
- E - Remote Hydraulic Lever (**SCV II**)
- F - Remote Hydraulic Lever (**SCV III**)
- G - Hitch Control
- H - Remote Hydraulic Lever (**SCV IV**)
- I - Hitch Rate of Drop [Inside Armrest]
- J - Hitch Height Limit [Inside Armrest]
- K - Hitch Load/Depth Control [Inside Armrest]

omar172611 - 9100, 9200, 9300 and 9400 Tractors (030001-040000) Side Console

Side Console

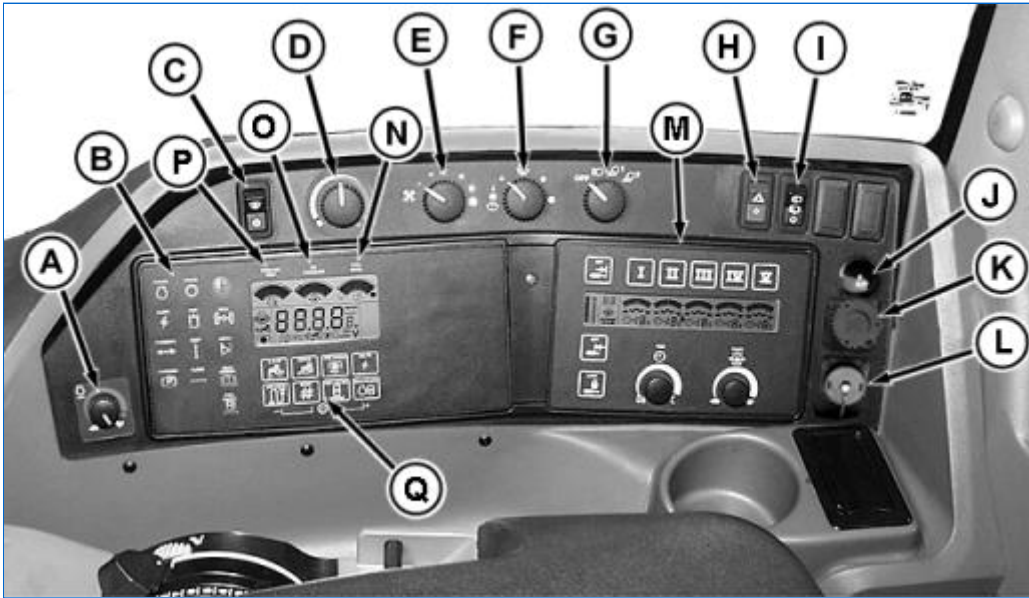

RW26734-UN: Side Console-Controls/Instruments

LEGEND:

- A - Field Cruise
- B - Vehicle Monitor
- C - Air Conditioning Switch
- D - Temperature Control
- E - Blower Speed Control
- F - Front Wiper Switch
- G - Light Switch
- H - Hazard Light Switch
- I - Rear Washer/Wiper Switch (*Optional*)
- J - Cigarette Lighter
- K - Diagnostic Outlet [Used by your John Deere Dealer]
- L - Convenience Electrical Outlet
- M - SCV TouchSet Control Panel
- N - Fuel Level
- O - Oil Pressure
- P - Coolant Temperature
- Q - Display Functions

omar172611 - 9100, 9200, 9300 and 9400 Tractors (030001-040000) Corner Post Display

Corner Post Display

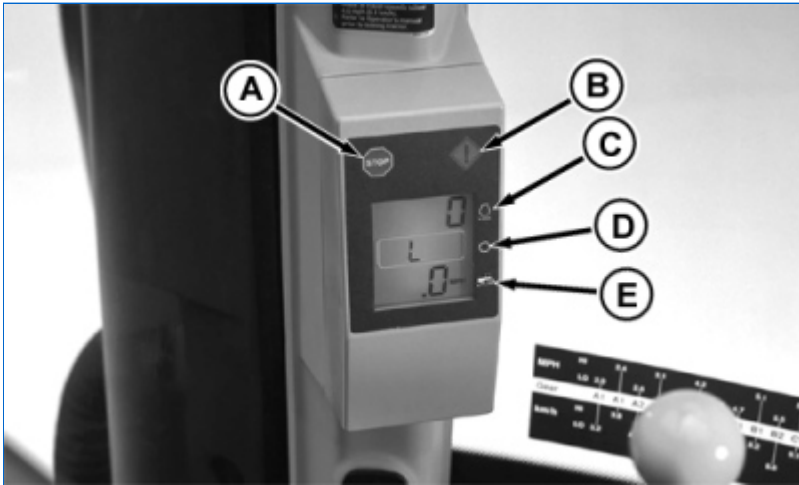

RW26059-UN: Corner Post Display-Controls/Instruments

LEGEND:

- A - Stop Engine Symbol
- B - Service Alert Symbol
- C - Engine Speed
- D - Transmission (Hi/Lo)
- E - Ground Speed

NOTE:

Display (E) indicates true ground speed WITH radar or wheel speed WITHOUT radar.



Suggest:

For more complete manuals. Please go to the home page.

<https://www.ebooklibonline.com>

If the above button click is invalid. Please download this document first, and then click the above link to download the complete manual.

Thank you so much for reading

omar172611 - 9100, 9200, 9300 and 9400 Tractors (030001-040000) Vehicle Monitor Warning System

Vehicle Monitor Warning System



RW26071-UN: Corner Post Display

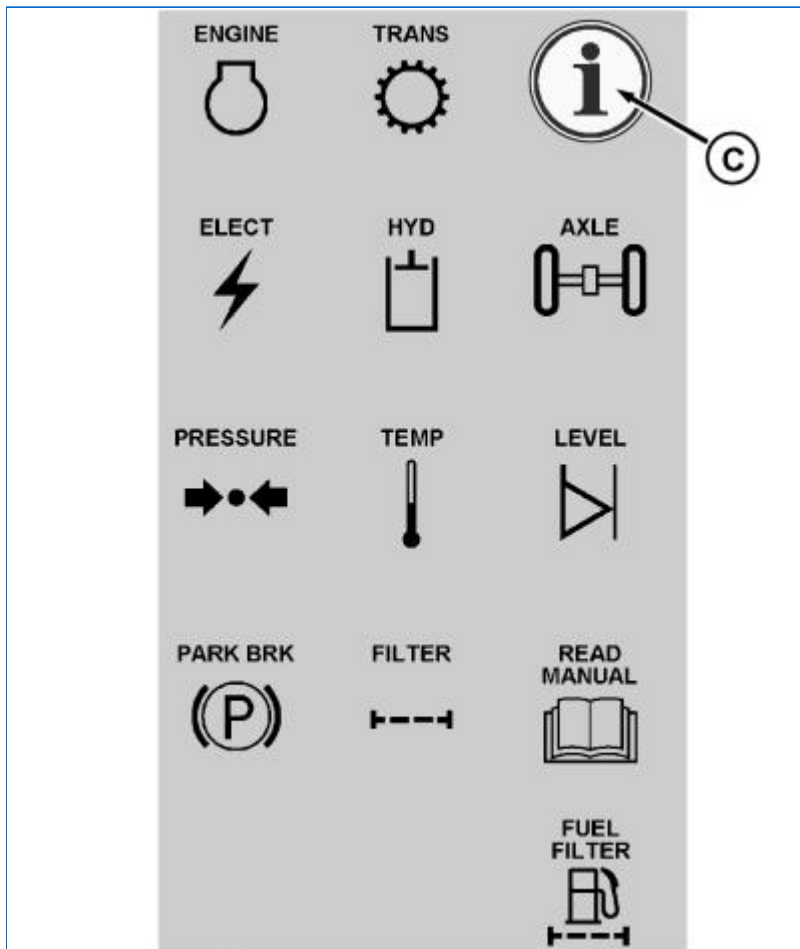

RW26735-UN: Vehicle Monitor Indicators

LEGEND:

- A - PRIORITY-Stop Engine Symbol
- B - PRIORITY-Service Alert Symbol
- C - PRIORITY-Information Symbol

IMPORTANT:

See your John Deere Dealer if any system indicates malfunction.

Vehicle monitor warning system alerts operator to malfunctions or needed service of the engine, transmission, electrical and hydraulic systems.

Indicators light and warning sounds momentarily when the key switch is turned to the ON position.

A serious malfunction is indicated when the **Stop Engine Symbol** (A) flashes and warning continues to sound in conjunction with a system indicator and function indicator. **Stop engine immediately** and determine the cause.

A serious problem has developed when the **Service Alert Symbol** (B) flashes and warning sounds five times in conjunction with a system, function, or status indicator. Observe gauges and indicator lights.

A problem has developed when the **Information Symbol** (C) flashes in conjunction with a system, function, or status indicator. Continue to operate tractor and address problem when convenient.

Service codes can be viewed on the digital display whenever a "priority" lights. (See Changing Display Functions in this section.) One problem will be displayed at a time, with most severe problem overriding all others. (See Service Codes Section.)

<https://www.ebooklibonline.com>

Hello dear friend!

Thank you very much for reading.

Enter the link into your browser.

The full manual is available for immediate download.

<https://www.ebooklibonline.com>