

MP9041

John Deere > Turf And Utility >TRACTOR, LAWN AND GARDEN >345 - TRACTOR, LAWN AND GARDEN >325, 335 and 345 Lawn and Garden Tractors >20 ENGINE (325) (FC540V) >ST571044 - ENGINE AND SHORT BLOCK (325) (FC540V)

KEY	PART NO.	PART NAME	QTY	Serial No.	REMARKS
1	AM121297	SHORT BLOCK ASSEMBLY	1		(SUB AM131151)
1	AM128736	SHORT BLOCK ASSEMBLY	1		(SUB AM131151)
1	AM131151	SHORT BLOCK ASSEMBLY	1		(SUB FOR AM130359)
..	AM120762	GASOLINE ENGINE	1	____-226612	(MARKED FC540V-AS15) (SUB AM131151)
..	AM121610	GASOLINE ENGINE	1	A00385-A13580	(MARKED FC540V-DS15) (SUB AM131151)
..	AM122325	GASOLINE ENGINE	1	A17448-A55916	(MARKED FC540V-ES15) (CARB CERTIFIED) (SUB AM131151)
..	AM124765	GASOLINE ENGINE	1	A55628-____	(MARKED FC540V-FS15) (CARB CERTIFIED) (SUB AM131151)

<https://www.ebooklibonline.com>

Hello dear friend!

Thank you very much for reading.

Enter the link into your browser.

The full manual is available for immediate download.

<https://www.ebooklibonline.com>

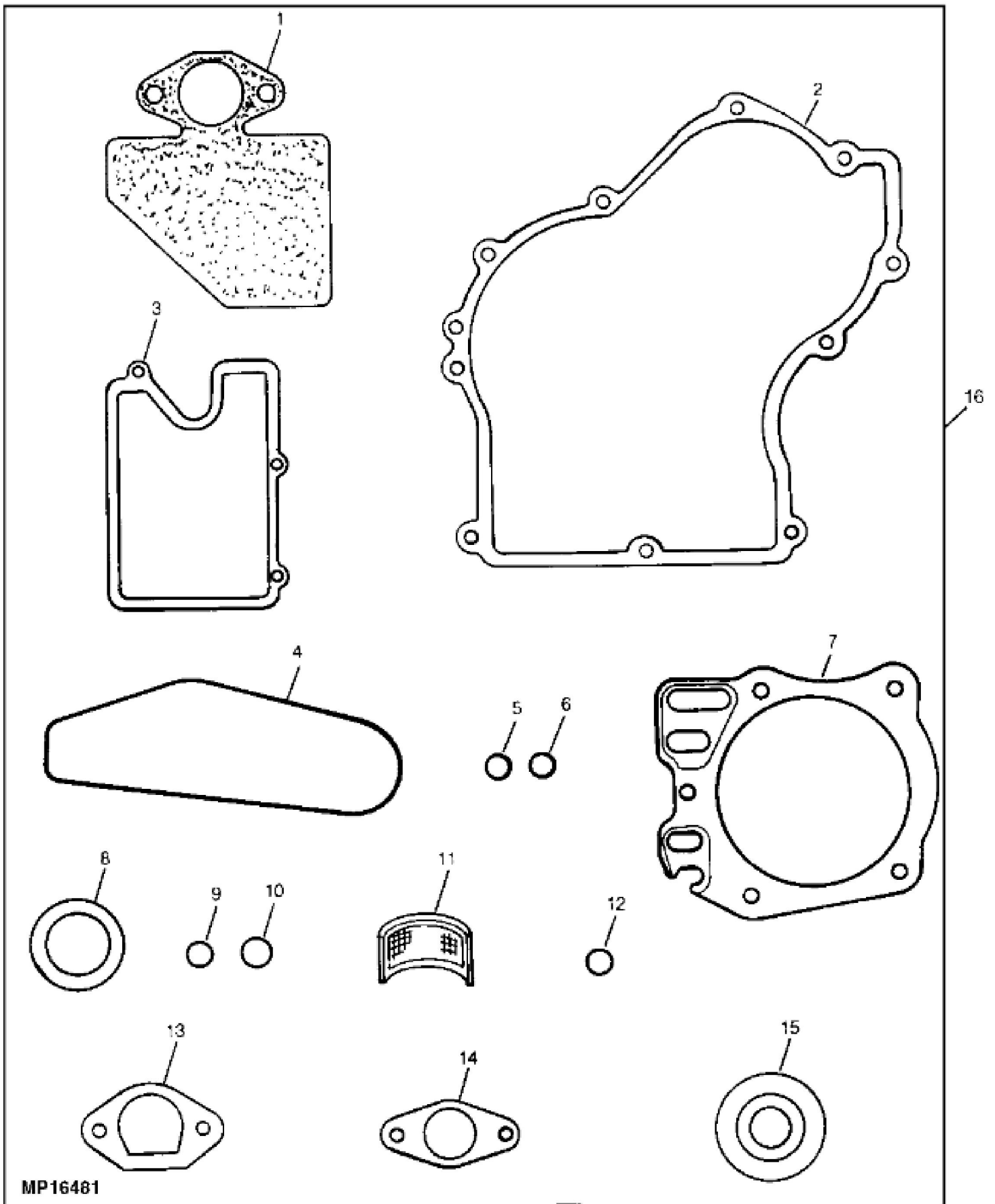

MP16481

John Deere > Turf And Utility >TRACTOR, LAWN AND GARDEN >345 - TRACTOR, LAWN AND GARDEN >325, 335 and 345 Lawn and Garden Tractors >20 ENGINE (325) (FC540V) >ST571045 - ENGINE GASKET KIT (325) (FC540V)

KEY	PART NO.	PART NAME	QTY	Serial No.	REMARKS
1	M115070	GASKET	1		AIR CLEANER
2	M143232	GASKET	1		CRANKCASE (SUB FOR M118781)
3	M70018	GASKET	1		RUBBER
4	M70024	GASKET	1		AIR FILTER
5	M134017	O-RING	2		OIL FILTER MOUNTING BRACKET (SUB FOR M70071)
6	M70096	O-RING	1		COUNTER WEIGHT SHAFT
7	M77752	ENGINE CYLINDER HEAD GASKET	1		
8	M88451	SEAL	1		CRANKSHAFT
9	M88478	O-RING	1		OIL FILLER NECK
10	M88482	GASKET	1		OIL GAUGE
11	M97206	SCREEN	1		OIL PUMP
12	M97209	O-RING	1		OIL DRAIN EXTENSION
13	M97275	GASKET	1		CARBURETOR BASE
14	M97276	GASKET	1		CARBURETOR INSULATOR
15	M124523	SEAL	1	A00385-A13580	CRANKSHAFT (SUB FOR PT13344)
15	M124523	SEAL	1	A17448-_____	CRANKSHAFT (SUB FOR PT13344)
16	AM124820	GASKET KIT	1		ENGINE (SUB FOR AM121298)

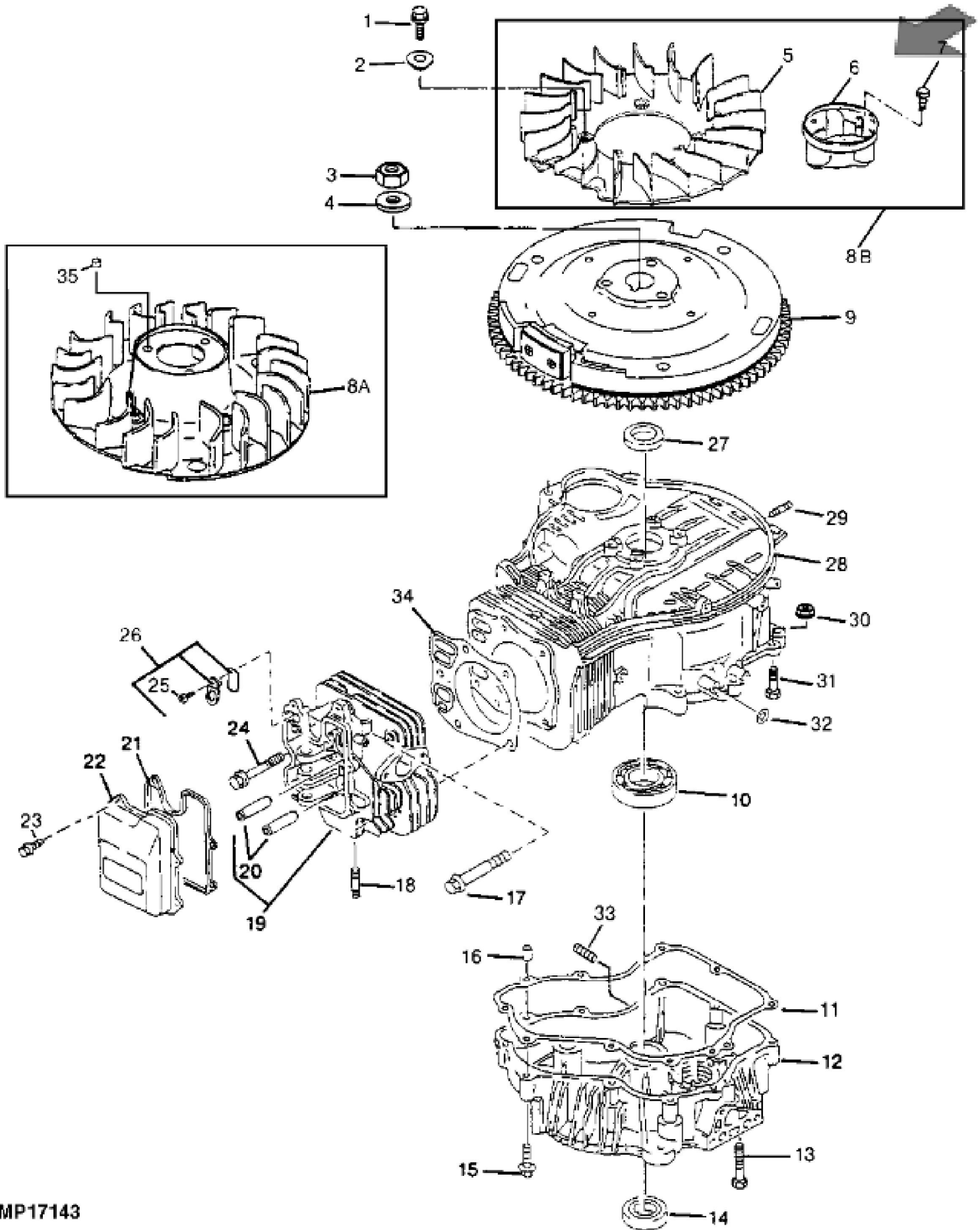

John Deere > Turf And Utility >TRACTOR, LAWN AND GARDEN >345 - TRACTOR, LAWN AND GARDEN >325, 335 and 345 Lawn and Garden Tractors >20 ENGINE (325) (FC540V) >ST571046 - CYLINDER HEAD AND CRANKCASE (325) (FC540V)

KEY	PART NO.	PART NAME	QTY	Serial No.	REMARKS
1	19M7775	SCREW	4		M6 X 16
2	M97238	BUSHING	4		
3	M70119	NUT	1		
4	M70120	WASHER	1		
5	M131939	FAN	1		NLA; (ENGINE MARKED FC540V-FS15)
6	M70082	BRACKET	1		(ENGINE MARKED FC540V-FS15)
7	19M7866	SCREW	3		M8 X 20, (ENGINE MARKED FC540V-FS15)
8A	M97271	FAN	1		(ENGINE MARKED FC540V-AS15, FC540V-DS15 AND FC540V-ES15) (SUB AM124767)
8B	AM124767	FAN KIT	1		NLA; ENGINE MARKED FC540V-FS15; SUB FOR M97271; Fan
9	AM109259	FLYWHEEL	1		ENGINE MARKED FC540V-AS15 AND FC540V-DS15
9	AM128804	FLYWHEEL	1		ENGINE MARKED FC540V-DS15, FC540V-ES15 AND FC540V-FS15; SUB FOR AM122178
10	JD8518	BALL BEARING	1		(SUB FOR CH16424)
11	M143232	GASKET	1		CRANKCASE (SUB FOR M118781 OR M120019)
12	AM117183	COVER	1		CRANKCASE
13	19M7868	SCREW	1		M8 X 30
14	M124523	SEAL	1	A00385-A13580	CRANKSHAFT (CRANKCASE) (SUB FOR PT13344)
14	M124523	SEAL	1	A17448-_____	CRANKSHAFT (CRANKCASE) (SUB FOR PT13344)
15	19M8318	SCREW	8		M8 X 45
16	M74252	PIN	2		
17	M70012	BOLT	4		
18	M117613	STUD	2		
19	AM109087	CYLINDER HEAD	1		
20	M97251	BRACKET	2		VALVE
21	M70018	GASKET	1		ROCKER ARM COVER
22	M70017	COVER	1		ROCKER ARM
23	19M7775	SCREW	4		M6 X 16
24	M77751	BOLT	1		
25	M95848	SCREW	1		
26	AM109222	KIT	1		VALVE AND PLATE
27	M88451	SEAL	1		CRANKSHAFT (CRANKCASE COVER)
28	AM101675	CRANKCASE	1		



Suggest:

For more complete manuals. Please go to the home page.

<https://www.ebooklibonline.com>

If the above button click is invalid. Please download this document first, and then click the above link to download the complete manual.

Thank you so much for reading

KEY	PART NO.	PART NAME	QTY	Serial No.	REMARKS
29	M88447	STUD	4		
30	14M7298	FLANGE NUT	1		M8, (ENGINE TO FRAME) (GROUND CABLE TO LEFT REAR MOUNTING BOLT ONLY)
31	19M7897	SCREW	1		M8 X 35, (ENGINE TO FRAME) (LEFT REAR, GROUND)
31	19M7867	SCREW	3		M8 X 25, (ENGINE TO FRAME) (ALL EXCEPT LEFT REAR)
32	M88987	SEAL	1		
33	M123645	DRAIN PLUG	1		NLA
34	M77752	ENGINE CYLINDER HEAD GASKET	1		
35	M97239	BUSHING	3		(ENGINE MARKED FC540V-AS15, FC540V-DS15 AND FC540V-ES15)

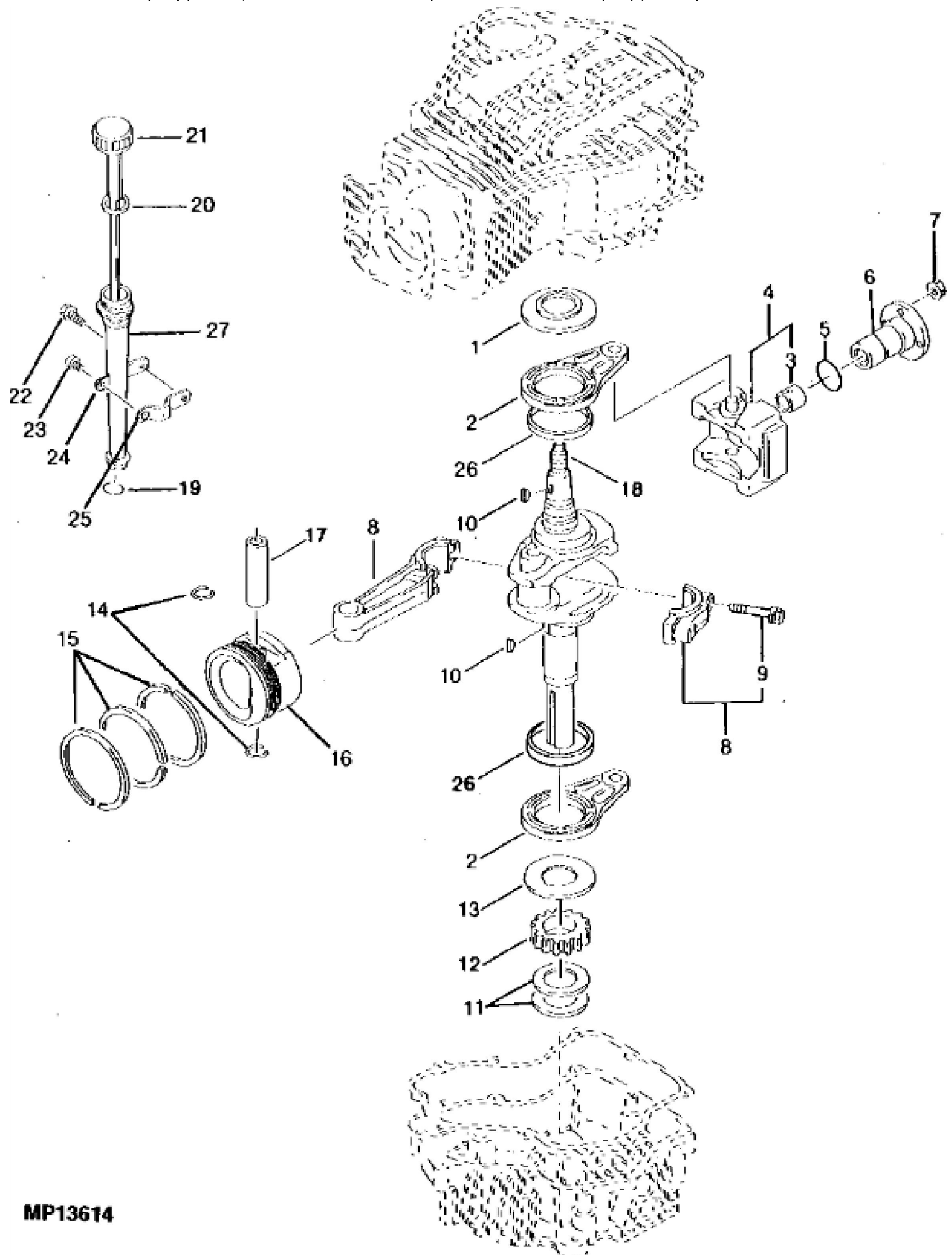

MP13614

<https://www.ebooklibonline.com>

Hello dear friend!

Thank you very much for reading.

Enter the link into your browser.

The full manual is available for immediate download.

<https://www.ebooklibonline.com>