

FIC EuVI Engines S Series

On-Road multipurpose

FICFL4IIS*A302

S30ENT6K25.00

S30ENT6K26.00

S30ENT6K27.00

Technical and Repair manual

Introduction

	Page
GENERAL INFORMATION	3
<input type="checkbox"/> SYMBOLS	3
<input type="checkbox"/> Warnings	3
<input type="checkbox"/> Service operations	3
GENERAL WARNINGS	5
GENERAL WARNINGS ON THE ELECTRIC SYSTEM	7
<input type="checkbox"/> Grounding and screening	8
OPTIONAL ELECTRICAL AND MECHANICAL PARTS INSTALLATIONS	9
CONVERSIONS BETWEEN THE MAIN UNITS OF MEASUREMENT OF THE INTERNATIONAL SYSTEM AND THE MOST COMMONLY USED DERIVED SIZES	9
PAGE HEADER AND FOOTER INTERPRETATION	10
UPDATE DATA	11

<https://www.ebooklibonline.com>

Hello dear friend!

Thank you very much for reading.

Enter the link into your browser.

The full manual is available for immediate download.

<https://www.ebooklibonline.com>

GENERAL INFORMATION

Manuals for repairs are split into Parts and Sections, each one of which is marked by a number; the contents of these sections are indicated in the general table of contents.

Sections with mechanical contents include technical data, tightening torque collections, tool lists, assembly connections - disconnections, overhauls at the bench, troubleshooting and scheduled maintenance.

On sections or parts of the electric/electronic system there are the descriptions of the electric network and the electronic systems assembly, wiring diagrams, electric characteristics of components.

Sections 1 and 2 describe the engine and its general features.

Section 3 describes the electrical part, concerning wiring, electrical and electronic equipment according to the specific use.

Section 4 includes scheduled maintenance.

Sections 5 and 6 concern the operations of removal/refitting of the main components and operations of general overhaul of engine fitted on a rotating stand.

Section 7 contains the technical data of the motor such as installation clearances and tightening torques.

Section 8 contains the special tools list.

The appendix provides a list of the general safety regulations which all operators, whether installers or maintenance technicians, must comply with to prevent any serious injury.

The manual uses proper symbols in its descriptions; the purpose of these symbols is to classify information. In particular, a set of symbols has been defined to classify warnings, while another set has been specified for service operations

SYMBOLS

Warnings



Danger for persons

Missing or incomplete observance of these prescriptions can cause serious danger for persons' safety.



Risk of serious damage to the assembly

The partial or total non-observance of these instructions could cause serious damage to the assembly and may nullify the warranty.



General danger

It includes the dangers of above described signals.



Environment protection

Indicates correct behaviour in order for the assembly use to be as environmentally friendly as possible.

NOTE Indicates an additional explanation for a piece of information.

Service operations

Example

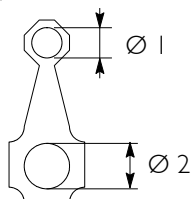



































Ø 1 = Housing for connecting rod small end bush.

Ø 2 = Housing for connecting rod bearings



Tighten to the specified torque + angle value

	Removal Disconnection		Intake
	Refitting Connection		Exhaust
	Removal Disassembly		Operation
	Fitting in place Assembly		Compression ratio
	Tighten to torque		Tolerance Weight difference
	Tighten to torque + angle value		Rolling torque
	Press or caulk		Rotation
	Regulation Adjustment		Angle Angular value
	Visual inspection Fitting position check		Preload
	Measurement Value to find Check		Number of revolutions
	Equipment		Temperature
	Surface for machining Machine finish		Pressure
	Interference Strained assembly		Oversized Higher than.... Maximum, peak
	Thickness Clearance		Undersized Less than.... Minimum
	Lubrication Damp Grease		Selection Classes Oversizing
	Sealant Adhesive		Temperature < 0 °C Cold Winter
	Air bleeding		Temperature > 0 °C Hot Summer

GENERAL WARNINGS



The warnings shown may not be representative of all the dangerous situations that may occur.

Therefore, supervisors should be contacted whenever a dangerous situation that has not been described occurs.

Use both specific and general-purpose toolings according to the prescriptions contained in respective use and maintenance handbooks.

Check the working condition and suitability of tools not subject to periodic review.

The manual handling of loads must be assessed in advance since it also depends not only on weight but also on its size and on the path.

Handling by mechanical means must be with hoisters proper as for weight as well as for shape and volume.

Hoisters, ropes and hooks used must show clear indications regarding maximum acceptable carrying capacity.

The use of such tools is strictly permitted by authorised personnel only.

Stay at a safe distance from the load and never below it.

In disassembly operations, always observe the provided prescriptions and prevent any mechanical parts being taken out from accidentally striking workshop personnel.

Shop activities performed by two technicians must always been executed with caution; avoid operations that may be dangerous for any collaborators due to lack of field of vision or incorrect position.

Keep any personnel not assigned to the operations clear of working area.

Learn the necessary concepts of operation and safety relating to the vehicle prior to working on it.

Scrupulously observe all safety warnings on the assembly.

Do not leave the assembly in motion unattended during repair work.

When working on an assembly off the ground, make sure that it is resting firmly on the appropriate supporting stands and that the manual/automatic safety devices are activated in the event of lifting with a hydraulic ramp.

When working on assemblies fuelled with natural gas, in addition to the instructions given in the document, also observe all the specific safety regulations provided.

Only remove radiator cap when the engine is cold by cautiously unscrewing it in order to let system residual pressure out.

Flammable fuels and all fluids and liquids must be handled with care, according to the indications provided in the 12 point cards of harmful materials.

Refuelling must be performed outdoors with the engine off, avoiding lit cigarettes, free flames or sparks, in order to prevent sudden fires/explosions.

Adequately store inflammable, corrosive and polluting fluids and liquids according to what provided by regulations in force. Strictly avoid using containers for food to store harmful liquids.

Avoid drilling or burning pressurised containers and discard cloths impregnated with inflammable substances into suitable containers.

Worn out, damaged or consumable parts must be replaced with original spare parts.

During workshop activities, always keep the workplace clean; promptly free or clean floors of any accidental spills and stains of liquids and oils.

Electric sockets and electrical equipment necessary to perform repair operations must meet safety rules.



Wear all required P.P.E and garments when called for by the operation at issue.

Contact with moving parts may cause serious injuries. Use suitable, preferably tight-fitting garments and avoid wearing jewellery, scarves, etc.

Do not leave the engine running in workshops not equipped with a pipe to extract exhaust fumes outside.

Do not breathe fumes from heating or welding of paint, as they are harmful; operate outdoors or in well-ventilated areas.

Wear an appropriate respirator in the presence of paint dust.

Avoid contact with hot water or steam from the engine, radiator and hoses as they could cause serious burns.

Avoid direct contact with liquids and fluids inside vehicle systems; consult the I 2 remedy points sheet if accidental contact occurs.



Before overhauling, clean the assemblies and make sure they are integral and complete.

Tidy up detached or disassembled parts with their securing elements (screws, nuts, etc.) into special containers.

Check the integrity of the parts that prevent the loosening of screws: split washers, split pins, clips, etc. Self-locking nuts with nylon inserts must always be replaced.

Avoid contact of rubber with diesel fuel, petrol or other incompatible substances.

Before pressure washing mechanical parts, protect electrical connectors and any control units.

The tightening of screws and nuts should always be carried out according to directions. FPT's sales and assistance network is available to provide any clarifications necessary to carry out any repair work not covered by this document.

Before welding:

- Disconnect all electronic control units and unplug the power cable from the battery's positive terminal (connecting it to the chassis ground) and connectors.
- Remove paint by using proper solvents or paint removers and clean relevant surfaces with soap and water.
- Wait approximately 15 minutes before proceeding with welding.
- Use suitable fire-resistant protections to protect hoses or other components in which fluids or other flammable materials flow when welding.

Should the vehicle be subjected to temperatures exceeding 80°C (dryer ovens), remove the electronic control units.



The disposal of all liquids and fluids must be performed with full observance of specific rules in force.

GENERAL WARNINGS ON THE ELECTRIC SYSTEM



When having to operate on the electrical/electronic circuit, disconnect the batteries from the circuit, disconnecting the chassis earth cable first of all from the negative terminal of the battery.

Before connecting the batteries to the system, make sure that the system is suitably insulated.

Disconnect the external recharging apparatus from the public utility network before removing the apparatus pins from the battery terminals.

Do not cause sparks to verify the presence of voltage in a circuit.

Do not use a test lamp to verify circuit continuity, but proper control equipment only.

Make sure that the wirings of electronic devices (length, type of cable, location, strapping, connection of screen braiding, grounding, etc.) conform with the FPT system and that they are carefully restored after repair or maintenance work.

Measurements on the ECUs, jack connections and electrical connections of components must be done only on regular test lines, with special jacks and jack bushings.

Never use improvised equipment like metal wires, screwdrivers, pins or similar.

This may not only cause short circuits, but also damage the jack connectors, resulting in poor contact.



Do not use fast chargers to start up the engine.

Start up must only be performed with either separate batteries or special truck.

Incorrect polarisation of voltage supply to the electronic control units (for example, incorrect polarization of batteries) may lead to their destruction.

Disconnect the batteries from the system during their recharging with an external apparatus.

On connecting, only screw connector (temperature sensors, pressure sensors, etc.) nuts to the prescribed tightening torque.

Isolate the circuit prior to disconnecting the junction connector from an electronic control unit.

Do not directly supply current to components served by electronic control units with nominal vehicle voltage.

The cables must be routed in such a way as to be parallel to the reference plane, as close as possible to the chassis/body.

Upon completing work on the electrical circuit, restore the electrical connectors and wiring as originally provided.

NOTE The connectors are shown from cable side.

Connector views contained in the manual are representative of cable side.

Grounding and screening

The negative leads connected to a system grounding point must be as short as possible and connected to one another in Δ configuration; make sure that they are tightened in an orderly and adequate manner (Figure 1 ref. M).

The following precautions must be observed regarding the electronic components:

- The electronic control units must be connected to the circuit's ground when they have metallic casing.
- Electronic control unit negative cables must be connected to a system ground point, such as the dashboard compartment ground (do not use "serial" or "chain" connections), and to the negative terminal of the battery/ies.
- Even if not connected to the circuit ground/battery negative terminal, analog ground (sensors) should have optimal isolation. Consequently, particular care should be given to terminal parasitic resistances: oxidation, clinching defects, etc.
- The metal braid of shielded circuits must be in electric contact only at the end towards the control unit where the signal enters (Figure 2).
- In the case of junction connectors, the unshielded section d , near the connectors must be as short as possible (Figure 2).
- The cables must be routed in such a way as to be parallel to the reference plane, as close as possible to the chassis/body.

Figure 1

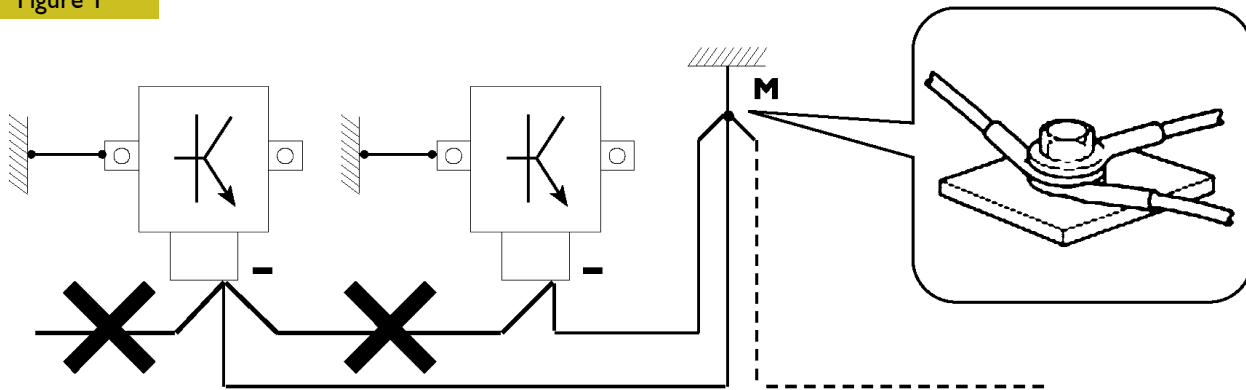

1. "DELTA" CONNECTIONS OF NEGATIVE CABLES TO THE CIRCUIT EARTH M

Figure 2

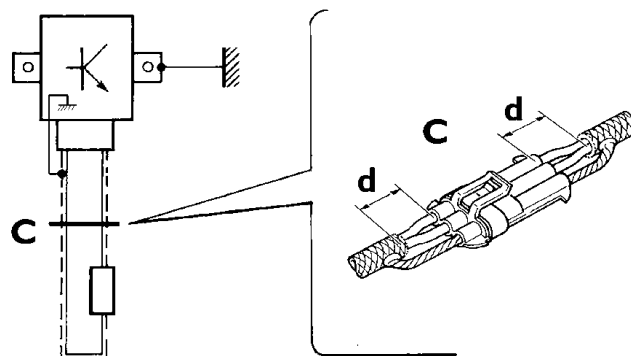

2. SHIELDING BY METAL BRAID OF A CABLE TO AN ELECTRONIC COMPONENT - C. CONNECTOR
d. DISTANCE $\rightarrow 0$

88039

OPTIONAL ELECTRICAL AND MECHANICAL PARTS INSTALLATIONS

Accessory installation, additions and changes on the assembly must be carried out in compliance with the FPT assembly directives.

It is reminded that, especially with regard to the electric system, several electric sockets are provided for as standard (or optional) sockets in order to simplify and normalise the electrical intervention by fitters.



It is strictly forbidden to carry out any modifications or connections to the electronic control unit wiring.

In particular, the data line between the control units (CAN line) is to be considered untouchable.

CONVERSIONS BETWEEN THE MAIN UNITS OF MEASUREMENT OF THE INTERNATIONAL SYSTEM AND THE MOST COMMONLY USED DERIVED SIZES

Power

1 kW	=	1.36 HP
1 kW	=	1.34 hp
1 CV	=	0.735 kW
1 CV	=	0.986 hp
1 hp	=	0.746 kW
1 hp	=	1.014 HP

NOTE the unit HP is converted into hp for simplicity according to a 1:1 ratio
1 hp = 1 HP

Torque

1 Nm	=	0.1019 kgm
1 kgm	=	9.81 Nm

Revolutions per time unit

1 rpm	=	0.1047 rad/s
1 rad/s	=	9.55 rpm

Pressure

1 bar	=	1.02 kg/cm ²
1 kg/cm ²	=	0.981 bar
1 bar	=	10 ⁵ Pa

NOTE Where accuracy is not particularly needed:

- the unit Nm is converted into kgm for simplicity according to a ratio of 10:1
1 kgm = 10 Nm;
- the unit bar is converted into kg/cm² for simplicity according to a ratio of 1:1
1 kg/cm² = 1 bar.

Temperature

0 °C	=	273.15 K
0 °F	=	255.37 K
0 °C	=	32 °F (the conversion factor between Celsius and Fahrenheit is 1:1.8)

PAGE HEADER AND FOOTER INTERPRETATION

Type of engine	Section title	Page number
----------------	---------------	-------------

MOTORI NEF F4HE

SEZIONE 4 - REVISIONE MECCANICA GENERALE 11

REVISIONE MOTORE 4 E 6 CIL. SMONTAGGIO DEL MOTORE AL BANCO

La trattazione seguente prevede che il motore sia stato montato sul cavalletto rotativo e si sia proceduto alla rimozione di tutti i componenti specifici dell'applicazione Iveco Motors (vedere la Sezione 3 del presente manuale).

La sezione riguarda quindi tutte le più importanti procedure di revisione del basamento motore.

Le operazioni seguenti riguardano il motore 4 cilindri, ma risultano analoghe per il 6 cilindri.

Figura 1

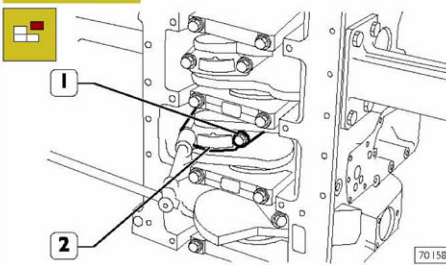

Svitare le viti di fissaggio (1) e rimuovere i cappelli di biella (2). Sfilare gli stantuffi completi di bielle dalla parte superiore del basamento.

NOTA Mantenere i semicuscinetti nei rispettivi alloggiamenti, poiché, in caso di un loro utilizzo, dovranno essere montati nella posizione riscontrata allo smontaggio.

Figura 2

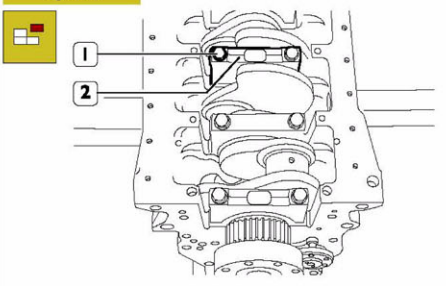

Rimuovere le viti (1) e smontare i cappelli di banco (2).

Figura 3

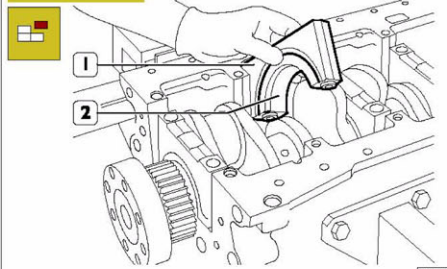

Il penultimo cappello di banco (1) e il relativo supporto (2) hanno il semicuscinetto (2) dotato di spallamento.

NOTA Le viti M12 dei cappelli di banco, devono essere sostituite se il diametro nominale della parte filettata che non lavora, presenta un diametro < 0,1 mm rispetto al valore nominale.

NOTA Annotare la posizione di montaggio dei semicuscinetti inferiori e superiori, poiché in caso di un loro utilizzo, dovranno essere montati nella posizione riscontrata allo smontaggio.

Figura 4

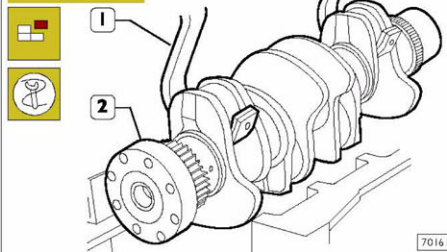

Con l'attrezzo 99360500 (1) e sollevatore rimuovere l'albero motore (2) dal basamento.

Figura 5

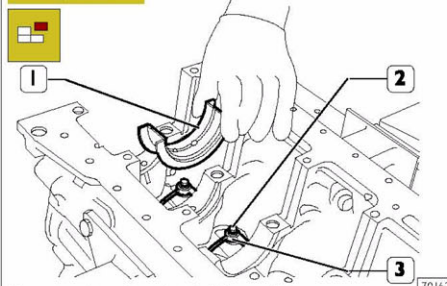

Smontare i semicuscinetti di banco (1). Rimuovere le viti (2) e smontare gli spruzzatori olio (3).

Print F2D32N003

Base - Dicembre 2006
Revi - Febbraio 2007

Number of printed copies	Language Publication
--------------------------	----------------------

Basic edition referring to closing phase of drafting month-year

When present, a month-year update (Revi) to the basic edition

UPDATE DATA

Section	Section name	Modification description	Page	Date of revision

FIC Engines EuVI

	Section
General Specifications	I
Operating diagrams	2
Electrical equipment	3
Scheduled Maintenance	4
Removal/refitting of the main engine components	5
General mechanical overhaul	6
Technical specifications	7
Tools	8
Safety prescriptions	Appendix

SECTION I

General Specifications

	Page
TECHNICAL CODE	3
COMMERCIAL CODE	4
ISOMETRIC VIEWS OF ENGINE	5
POWER - TORQUE CURVES	6
ENGINE VIEWS	8
GENERAL SPECIFICATIONS	13

TECHNICAL CODE

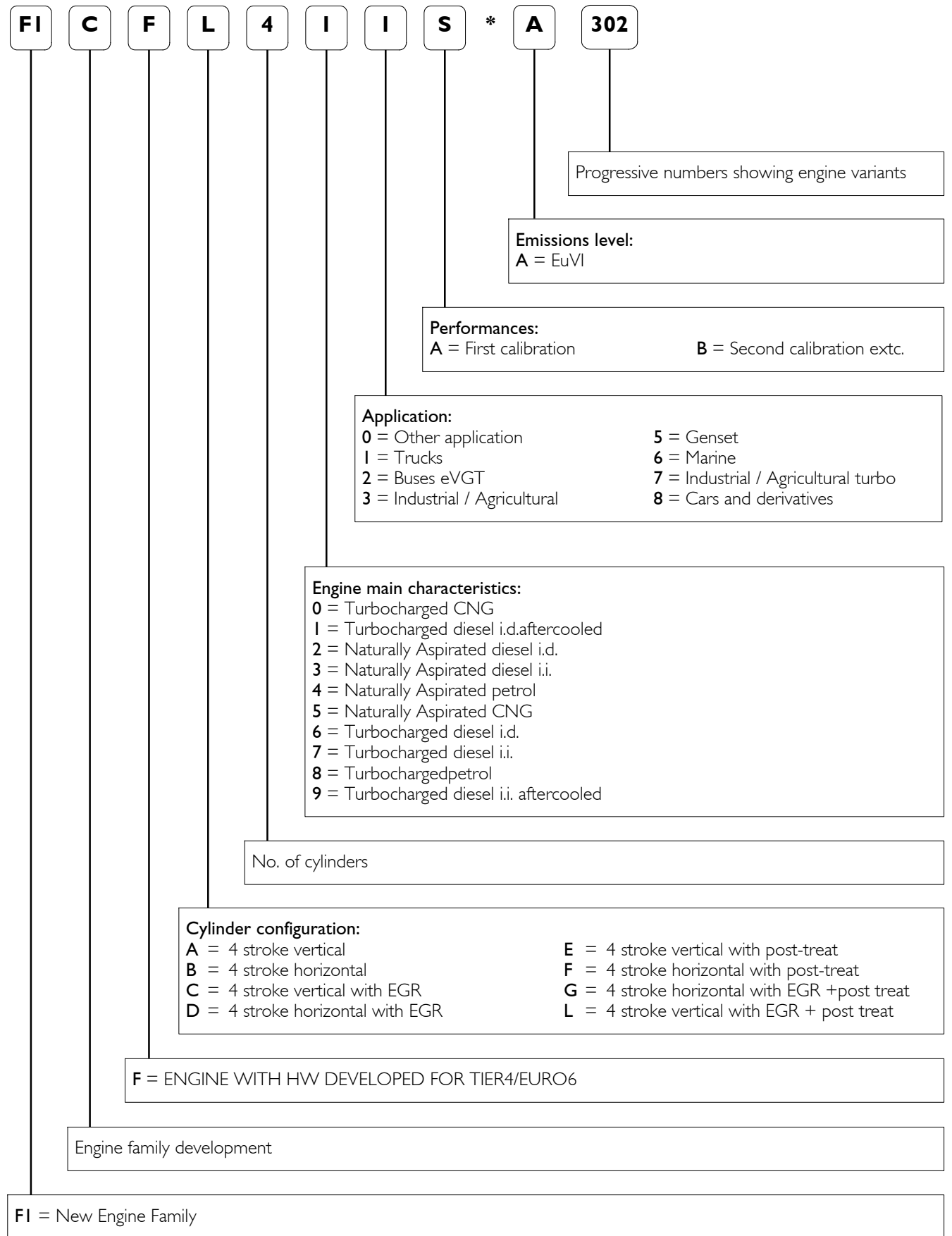



Suggest:

For more complete manuals. Please go to the home page.

<https://www.ebooklibonline.com>

If the above button click is invalid. Please download this document first, and then click the above link to download the complete manual.

Thank you so much for reading

COMMERCIAL CODE

S **30** **E** **N** **T** **6**

Emission levels:

A = 2002/88 CE
C = Euro 3
D = Double omologation Europe (NRMM) and EPA-USA
E = Europe (NRMM)
F = Sprinkler
G = GAS
I = Not emissioned (without omologation)
L = Stage IV
M = Marine
R = R96 omologation
S = R96 TIER4B omologation
U = EPA - USA
X = Stage 3A - Tier 3
Y = Stage 3B - Tier 4A
Z = Tier4B
4 = Euro 4
5 = Euro 5
6 = Euro 6

Aspiration:

A = Natural
S = Supercharged
T = Supercharged with aftercooler

Crakcase:

N = Not structural (normal distribution)
S = Not structural (limited distribution)
R = Structural

Injection type:

E = Electronic
M = Mechanic

Displacement:

L *10 for displacement < 10 L

Engine:

C = Cursor
F = F5
N = NEF
S = FI
V = V Series

ISOMETRIC VIEW OF ENGINE

Figure 1

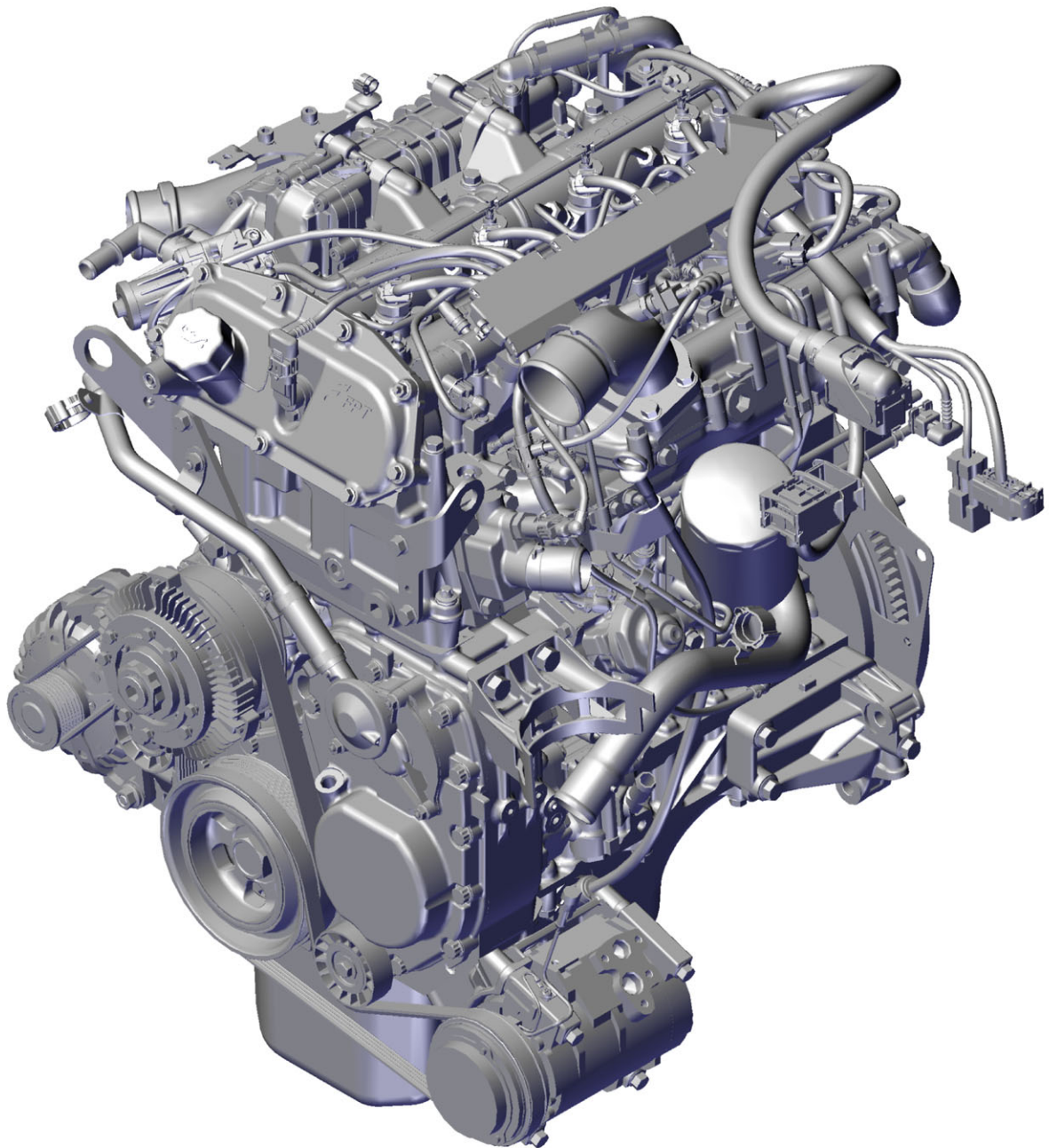

227511

<https://www.ebooklibonline.com>

Hello dear friend!

Thank you very much for reading.

Enter the link into your browser.

The full manual is available for immediate download.

<https://www.ebooklibonline.com>