

CURSOR SERIES TIER 4B / STAGE IV

Industrial application

TIER 4B

F2CFE6I3E*B0I2

F2CFE6I3A*B0I2

STAGE IV

F2CFE6I3E*B0I3

F2CFE6I3A*B0I3

Technical and Repair manual

AUXILIARY MEMBERS' BELT REMOVAL / REFITTING

Removal

Figure 1

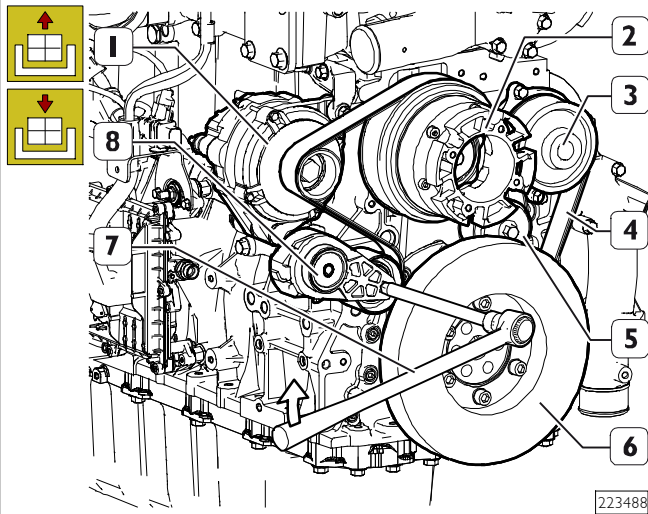

Pull the automatic belt tensioner (8) by using appropriate tool (7) and remove the auxiliary members' belt (4) from alternator (1), water pump (3), fan control pulley (2), crankshaft pulley with damper (6) and fixed guide roller (5).

Refitting

Fit the auxiliary members' belt (4) on the pulleys and guide roller.

Use the appropriate tool (7) on the automatic belt tensioner (8) in order to fit the new belt (4) in the operating position.

Additional adjustments are not required. The belt tension is adjusted automatically by the calibrated spring in the automatic belt tensioner (8).

Operate the engine for a few hours and check that the auxiliary members' belt (4) is properly fitted.

ALTERNATOR REMOVAL / REFITTING

Removal

Disconnect the electrical connections of the alternator.

Remove the auxiliary components drive belt as described in the relative procedure.

Figure 2

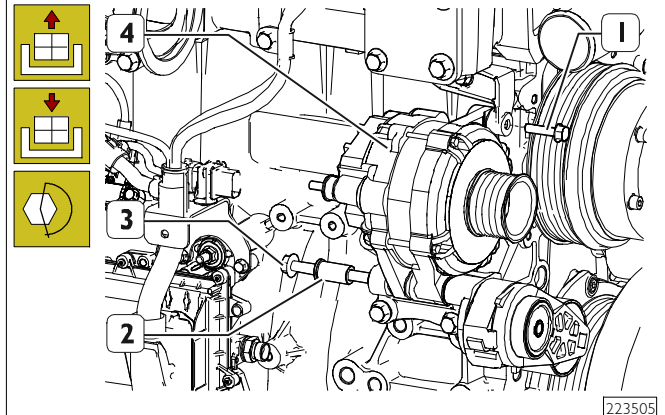

Unscrew fastening screws (1 and 3) and remove the alternator (4), recovering spacer (2).

Ref.	No.	Description
(1)	1	M8x1.25x35
(3)	1	M10x1.5x120

Refitting

Install alternator (4) on support and tighten fastening screws (1 and 3) to the prescribed torque.

Ref	No.	Description	Tightening torques
(1)	1	M8x1.25x35	24 ± 3 Nm
(3)	1	M10x1.5x120	43 ± 3 Nm

Install the auxiliary components drive belt as described in the relative procedure.

Connect the alternator electrical connections.

<https://www.ebooklibonline.com>

Hello dear friend!

Thank you very much for reading.

Enter the link into your browser.

The full manual is available for immediate download.

<https://www.ebooklibonline.com>

WATER PUMP REMOVAL / REFITTING

Removal

Drain off the coolant.

Remove the auxiliary components drive belt as described in the relative procedure.

Position a suitable container to catch any coolant.

Figure 3

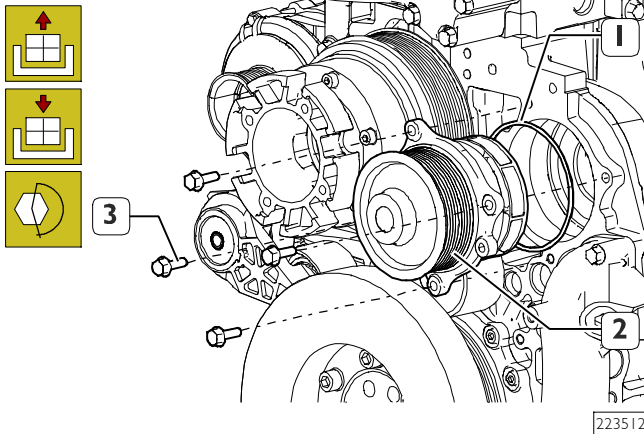

Unscrew the fastening screws (3) and remove the water pump (2) complete with gasket (1).

Ref	No.	Description
(3)	4	M8x1.25x25

Refitting

Apply a new seal ring (1) to the coolant pump (2).

Assemble the water pump (2) complete with its sealing gasket (1) and tighten the fastening screws (3) to the prescribed torque.

Ref	No.	Description	Tightening torques
(3)	4	M8x1.25x25	24.5 ± 2.5 Nm

Install the auxiliary components drive belt as described in the relative procedure.

NOTE Once installed, fill the engine coolant circuit.
Start the engine and check for coolant leaks.

THERMOSTAT REMOVAL / REFITTING

Removal

Figure 4

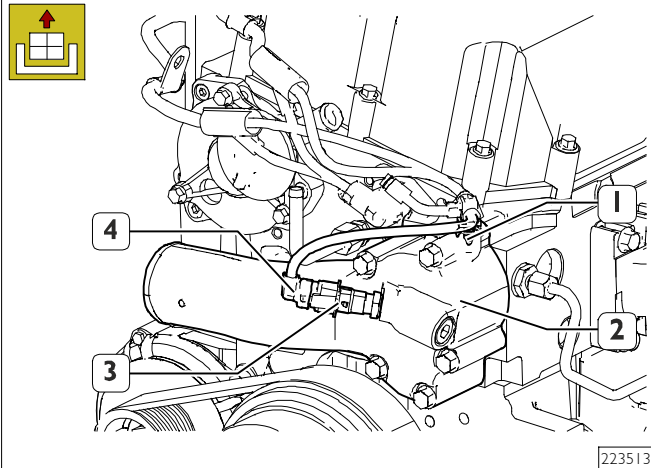

Unplug the engine cable (4) from the coolant temperature sensor (3), as described in the relative section.

Open the strap (1) holding the engine cable (4) to the engine coolant outlet pipe (2) and remove it.

Figure 5

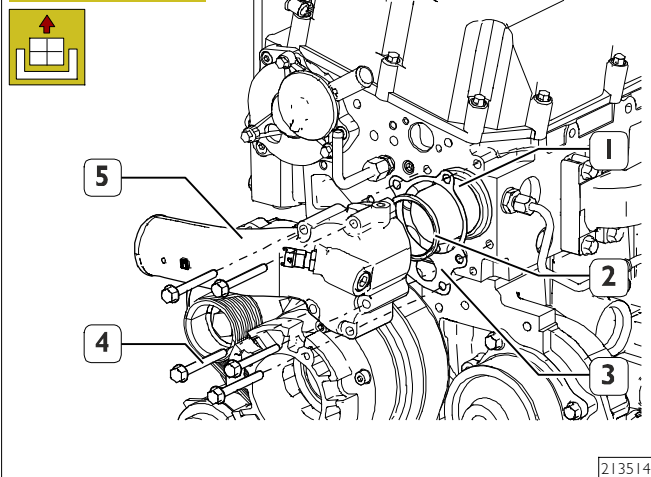

Unscrew the fastening screws (4) and disassemble the thermostat unit: remove the engine coolant outlet pipe (5) together with its gasket (3), the sealing ring (2) and the thermostat (1).

Ref	No.	Description
(4)	5	M8x1.25x70

Refitting

Figure 6

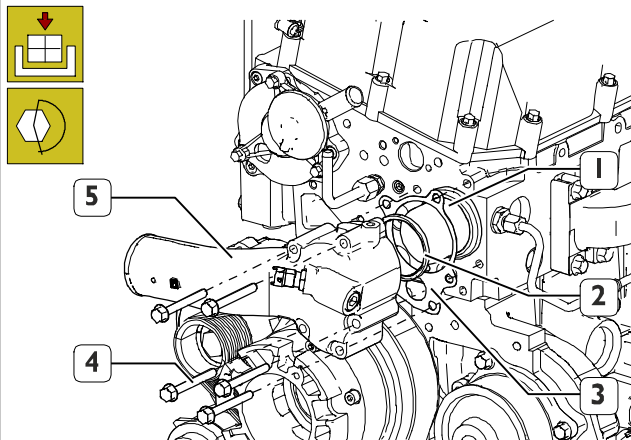

223514

Assemble the thermostat unit: fit the thermostat (1), a new sealing ring (2) and the engine coolant outlet pipe (5) complete with its gasket (3); tighten the fastening screws (4) to the prescribed torque.

Ref	No.	Description	Tightening torques
(4)	5	M8x1.25x70	24.5 ± 2.5 Nm

Figure 7

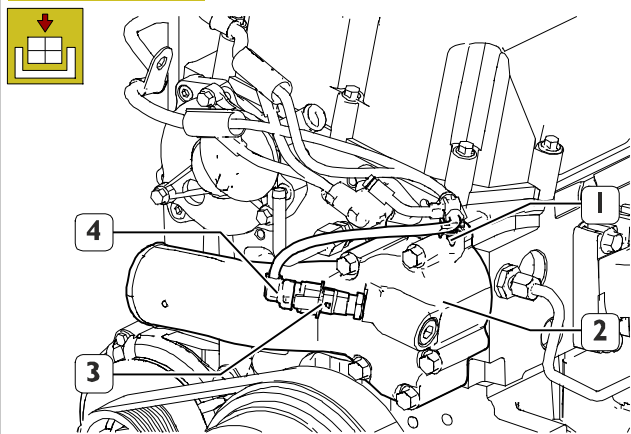

223513

Connect the engine cable (4) to the coolant temperature sensor (3), as described in the relative section.

Close the strap (1) retaining the engine cable (4) to the engine coolant outlet pipe (2).

ENGINE CONTROL UNIT REMOVAL / REFITTING

Removal

Figure 8

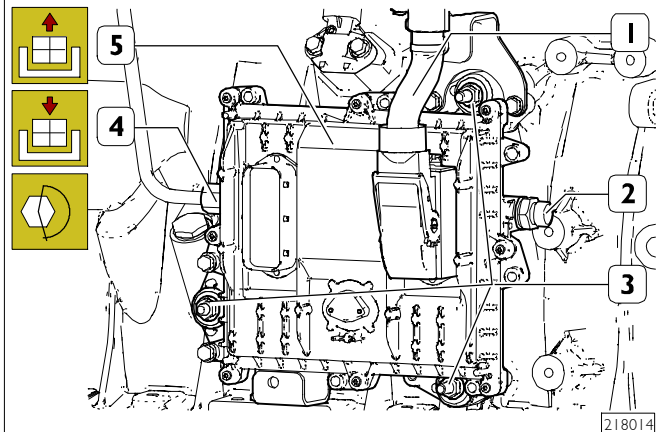

218014

Disconnect the engine cable (1) from the ECU (5), as described in the relative section.

Position a suitable container to catch any fuel.

Disconnect the retainer (2) and remove the low pressure fuel pipe from fuel pre-filter to the engine control unit heat exchanger.

Disconnect the retainer (4) and remove the low pressure fuel pipe from the engine control unit heat exchanger to to mechanical pump, as described in the relative section.

Unscrew the fastening nuts (3), and remove the ECU (5), including the heat exchanger.

Ref	No.	Description
(3)	3	M8x1.25
(4)	1	M16x1.5

Refitting

Fit the ECU (5) including the heat exchanger on the crankcase and tighten the fastening nuts (3) to the prescribed torque.

Connect the low pressure fuel pipe from the mechanical pump to the engine control unit heat exchanger by means of the retainer (4), as described in the relative procedure.

Connect the low pressure fuel pipe from fuel pre-filter to the engine control unit heat exchanger by means of the retainer (2).

Connect the engine cable (1) to the ECU (5), as described in the relative section.

Ref	No.	Description	Tightening torques
(3)	3	M8x1.25	24 ± 3 Nm
(4)	1	M16x1.5	30 ± 5 Nm

FUEL FILTER SUPPORT REMOVAL / REFITTING

Removal

Figure 9

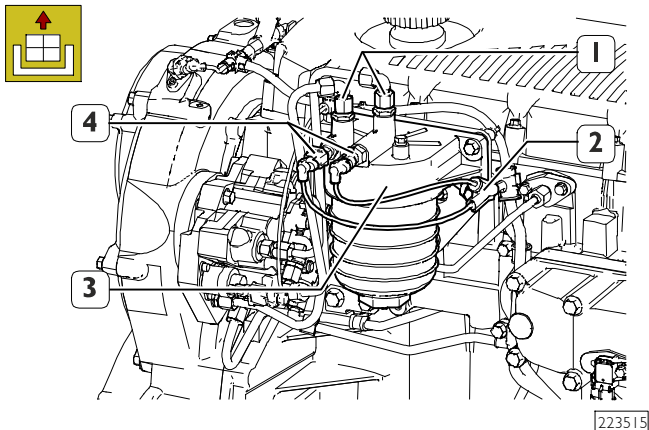

During this operation don't smoke and don't use free flames.
Avoid to breathe the vapours coming from filter.

Disconnect the sensor connections (4) of the engine cable (2) from the fuel filter support (3), as described in the relative procedure.

Disconnect the fittings (1) of the low pressure fuel pipes from fuel filter to high pressure pump and from mechanical pump to fuel filter.

Ref	No.	Description
(1)	2	M16x1.5

Figure 10

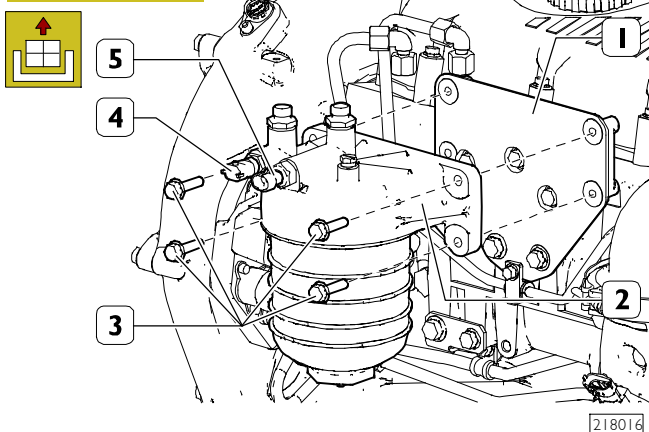

Place a container for collecting diesel under the fuel filter support (2).

Unscrew the fastening screws (3) and remove the fuel filter support (2) together with the fuel filter clogging (pressure drop) sensor (5) and NTC temperature sensor (4) from the engine cable supporting bracket (1).

Ref	No.	Description
(3)	4	M8x1.25x30

Refitting

Figure 11

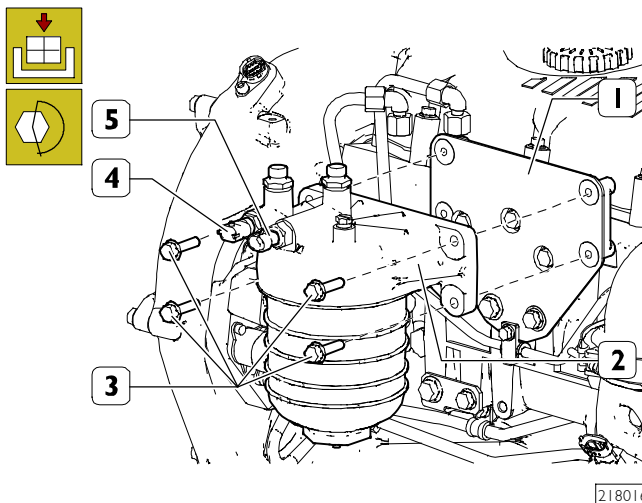

Fit the fuel filter support (2) together with the fuel filter clogging (pressure drop) sensor (5) and NTC temperature sensor (4) on the engine cable supporting bracket (1) and tighten the fastening screws (3) to the prescribed torque.

Ref	No.	Description	Tightening torques
(3)	4	M8x1.25x30	24 ± 3 Nm

Figure 12

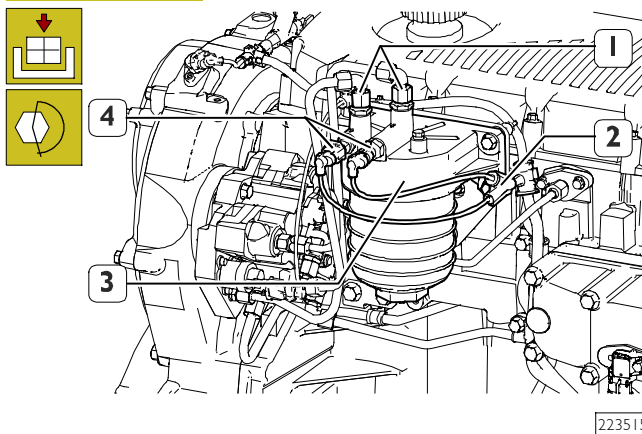

Connect the fittings (1) of the low pressure fuel pipes from fuel filter to high pressure pump and from mechanical pump to fuel filter.

Connect the sensor connections (4) of the engine cable (2) to the fuel filter support (3), as described in the relative procedure.

Ref	No.	Description	Tightening torques
(1)	2	M16x1.5	40 ± 5 Nm

FUEL HIGH-PRESSURE PUMP REMOVAL / REFITTING

Removal

Remove the fuel filter support as described in the relative procedure.

Figure 13

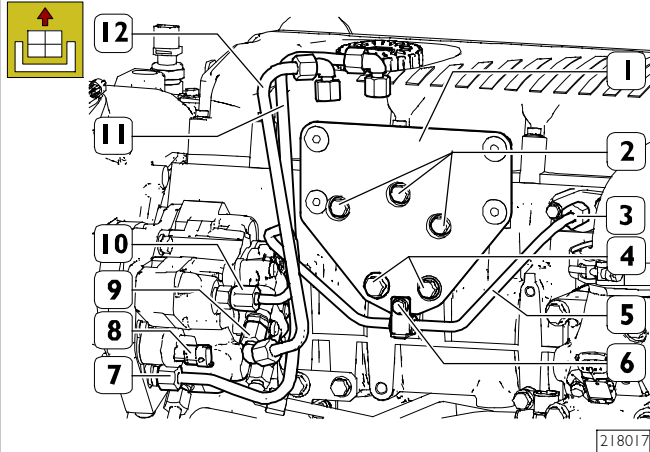

Disconnect the engine cable from the fuel high-pressure pump metering unit (8), as described in the relative procedure.

Disconnect the fittings (7 and 9) to remove the low pressure fuel pipe (11) from fuel filter to high-pressure pump and the pipe (12) from mechanical pump to fuel filter.

Unscrew the hose couplings (3 and 10) and the screw (6) to remove the high-pressure fuel pipe (5) from high-pressure pump to cylinder head.

Unscrew the fastening screws (2 and 4) and remove the fuel filter bracket (1).

Ref	No.	Description
(7,9)	2	M16x1.5
(3,10)	2	M14x1.5
(6)	1	M6x16
(2)	3	M8x1.25x35
(4)	1	M8x25
(4)	1	M10x25

Figure 14

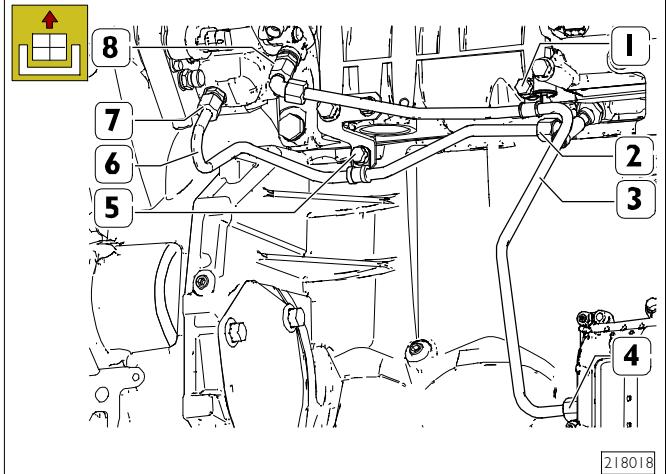

Disconnect the fittings (4 and 8) and the screw (1) to remove the low pressure fuel pipe (3) from ECU to mechanical pump.

Disconnect the fittings (2 and 7) and the screw (5) to remove the backflow fuel pipe (6) from high-pressure pump to fuel tank.

Ref	No.	Description
(4,8)	2	M16x1.5
(2,7)	2	M16x1.5
(1)	1	M8x1.25x25
(5)	1	M8x1.25x16

Figure 15

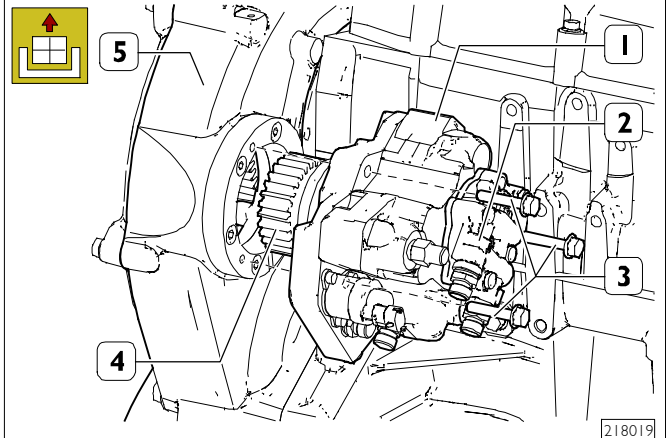

Ensure that the the fuel high-pressure pump (1) is suitably supported.

Unscrew the fastening screws (3) and remove the fuel high-pressure pump (1) complete with the mechanical pump (2) and the gear (4) from the flywheel housing-gear box carter (5).

Ref	No.	Description
(3)	3	M8x1.25x40

Refitting

Figure 16

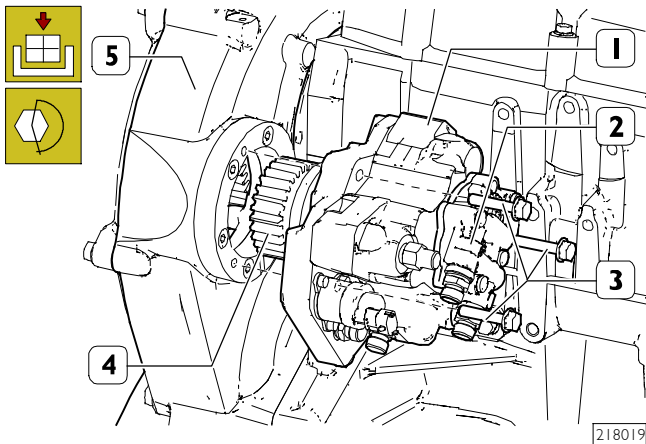

Fit the fuel high-pressure pump (1) complete with the mechanical pump (2) and the gear (4) into the flywheel housing-gear box carter (5).

Tighten the fastening screws (3) to the prescribed torque.

Ref	No.	Description	Tightening torques
(3)	3	M8x1.25x40	33 ± 3 Nm

Figure 17

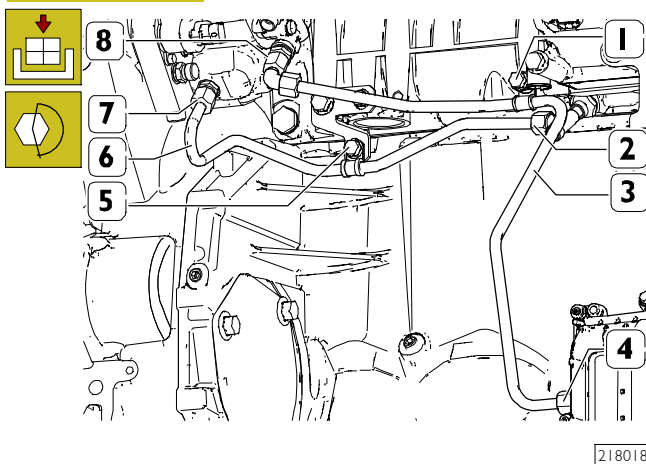

Connect the backflow fuel pipe (6) from high-pressure pump to fuel tank and tighten the fittings (2 and 7) and the screw (5) to the prescribed torque.

Connect the low pressure fuel pipe (3) from ECU to mechanical pump and tighten the fittings (4 and 8) and the screw (1) to the prescribed torque.

Ref	No.	Description	Tightening torques
(4,8)	2	M16x1.5	30 ± 5 Nm
(2,7)	2	M16x1.5	45 ± 5 Nm
(1)	1	M8x1.25x25	24.5 ± 2.5 Nm
(5)	1	M8x1.25x16	24.5 ± 2.5 Nm

Figure 18

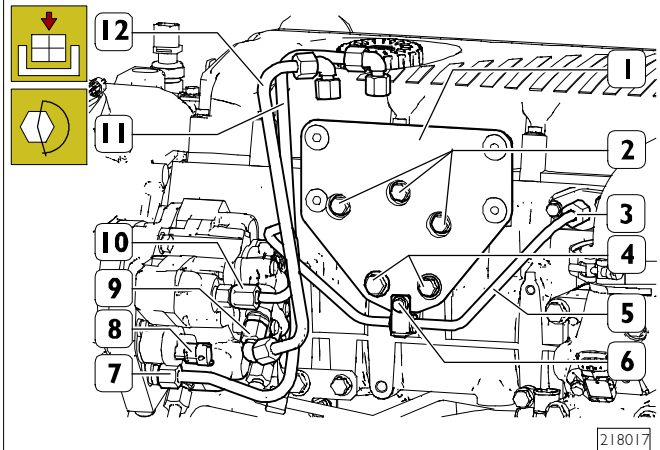

Fit the fuel filter bracket (1) and tighten the fastening screws (2 and 4) to the prescribed torque.

Connect the the high-pressure fuel pipe (5) from high-pressure pump to cylinder head and tighten the hose couplings (3 and 10) and the screw (6) to the prescribed torque.

Connect the low pressure fuel pipe (11) from fuel filter to high-pressure pump and the pipe (12) from mechanical pump to fuel filter and tighten the fittings (7 and 9) to the prescribed torque.

Fasten the engine cable to the retainers and connect the electrical connection to the fuel high-pressure pump metering unit (8), as described in the relative procedure.

Ref	No.	Description	Tightening torques
(7,9)	2	M16x1.5	30 ± 5 Nm
(3,10)	2	M14x1.5	35 ± 2 Nm
(6)	1	M6x16	10 ± 1 Nm
(2)	3	M8x1.25x35	24 ± 3 Nm
(4)	1	M8x25	24 ± 3 Nm
(4)	1	M10x25	37.5 ± 7.5 Nm

Install the fuel filter support as described in the relative procedure.



Suggest:

For more complete manuals. Please go to the home page.

<https://www.ebooklibonline.com>

If the above button click is invalid. Please download this document first, and then click the above link to download the complete manual.

Thank you so much for reading

COMMON RAIL REMOVAL / REFITTING

Removal

Figure 19

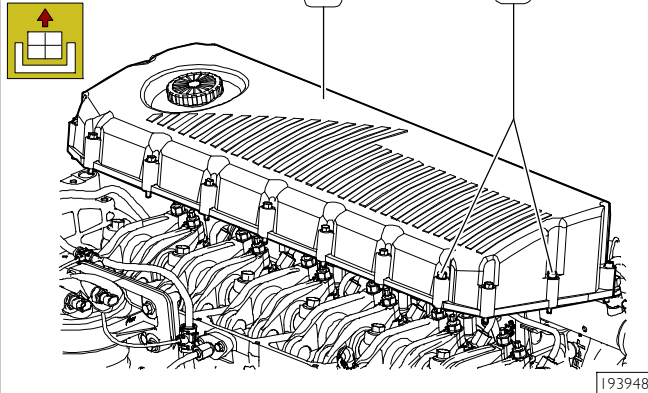

Unscrew the screws (2).
Remove cylinder head cover (1) and gasket.
Remove cable on head.

Ref	No.	Description
(2)	20	M6x1x50

Figure 20

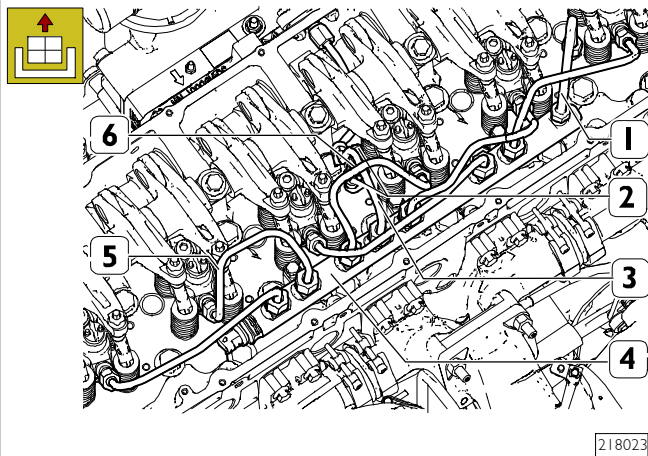

Disconnect fuel delivery pipes (5) between common rail (4) and electro-injectors, fuel supply pipe (3) between high-pressure pump and common rail (4) and fuel return pipe (1) between common rail (4) and cylinder head.

Unscrew the fastening screws (2) and remove the bracket (6) from the cylinder head.

Ref	No.	Description
(5)	6	M18x1.5
(5)	6	M14x1.5
(3)	1	M18x1.5
(3)	1	M14x1.5
(1)	2	M16x1.5

Figure 21

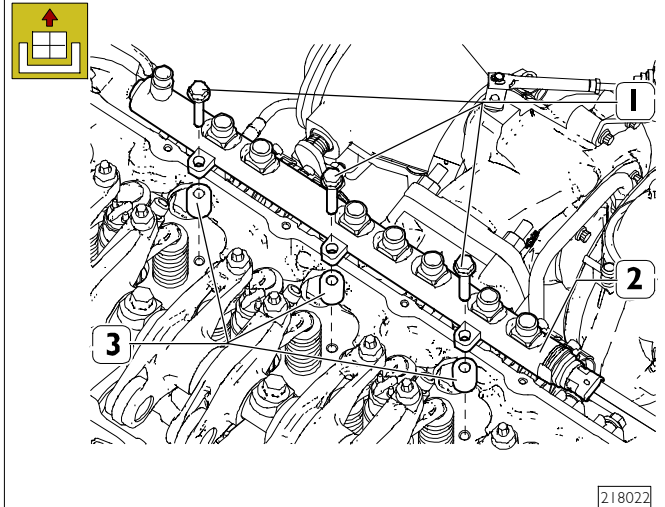

Unscrew n° 3 screws (1); remove common rail (2) and spacers (3).

Ref	No.	Description
(1)	3	M8

Refitting

Figure 22

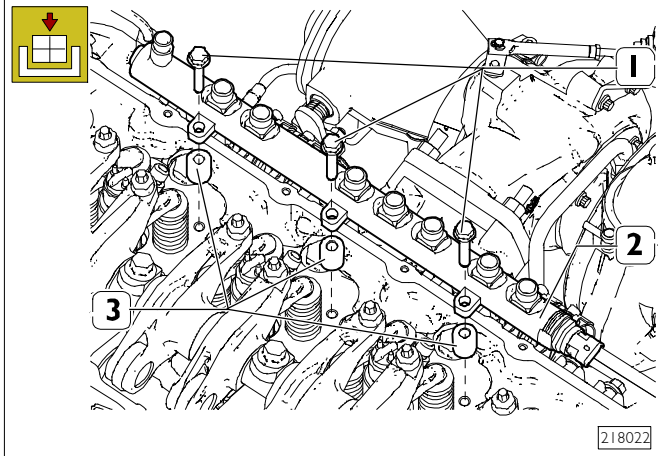

Install rail (2) and spacers (3) on cylinder head.
Lock n° 3 retaining screws (1) by hand.

Ref	No.	Description	Tightening torques
(1)	3	M8	23 ± 2 Nm

 The previously removed pipes can no longer be refit and must be replaced.

Figure 23



Install the common rail (3) and high-pressure fuel delivery pipes by proceeding as follows:

- Fit the common rail (3) on the cylinder head (5) and manually tighten the fastening screws (12).
- Check that the injectors are installed in correct position (equidistant from the springs) and locked to required torque.
- Fit the high-pressure fuel delivery pipes (6 and 8) and manually tighten the hose couplings (4, 7 and 13) first of all from common rail side and then from injector -cylinder head side;
- Fit the low-pressure fuel backflow pipe (1) and manually tighten the hose couplings (2) first of all from common rail side and then from cylinder head side;
- Tighten the hose couplings (2, 7 and 13) of injector-cylinder head side to the prescribed torque.
- Tighten the screws (12) fixing the common rail (3) onto cylinder head (5) to the prescribed torque.
- Tighten the hose couplings (2 and 4) of common rail side to the prescribed torque.
- Mount the bracket (10) and manually tighten the fastening screw (9).
- Tighten the screw (11) locking the high-pressure fuel delivery pipe (8) to the prescribed torque.
- Tighten the fastening screw (9) fixing the bracket (10) onto cylinder head (5) to the prescribed torque.

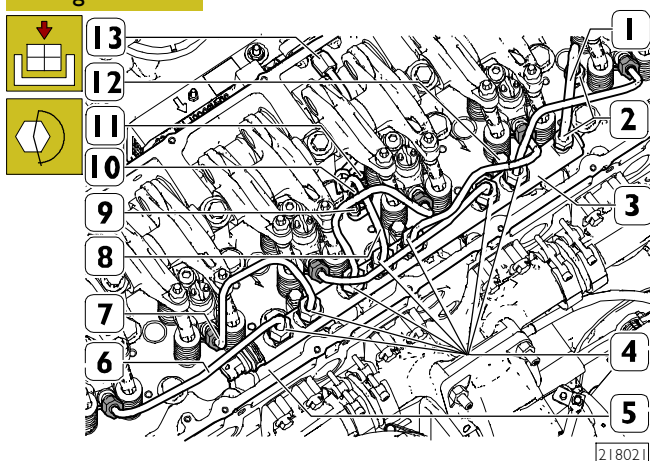
Ref	No.	Description	Tightening torques
(2)	2	M16x1.5	35 ± 2 Nm
(4)	7	M18x1.5	40 ± 2 Nm
(7)	6	M14x1.5	35 ± 2 Nm
(9)	1	M8x1.25x16	24 ± 3 Nm
(11)	1	M6x16	10 ± 1 Nm
(12)	3	M 8x45	24 ± 3 Nm
(13)	1	M14x1.5	35 ± 2 Nm

NOTE The high-pressure fuel delivery pipes must be replaced every time they are removed. The hose couplings must be tightened to torque using spanner 99368542 and torque wrench 99389833.



After fitting the high-pressure pipelines, during the following 20 hours of work, frequently check engine oil level (IT MUST NOT INCREASE).

NOTE After the assembly procedure, the fuel lines must definitely not touch each other so as not to get damaged because of the high stress due to engine vibration. The MINIMUM distance between the individual pipes must NOT be LESS than 2 mm.

End assembly procedure by connecting engine cable on head to injectors and rail sensor.

Figure 24

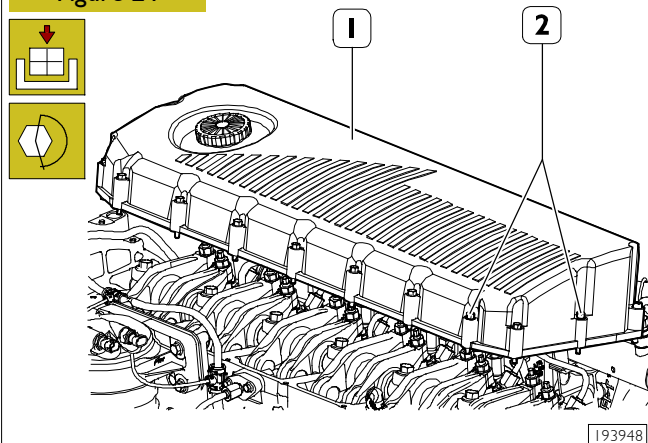

Fit the valve cover (1) with the related gasket and insert all the screws (2).

Tighten the fastening screws (2) to the prescribed torque following order and mode shown in the figure below.

Ref	No.	Description	Tightening torques
(2)	20	M6x1x50	8.5 ± 1.5 Nm

<https://www.ebooklibonline.com>

Hello dear friend!

Thank you very much for reading.

Enter the link into your browser.

The full manual is available for immediate download.

<https://www.ebooklibonline.com>