

# **CURSOR SERIES**

**C9**

**Technical and Repair manual**

## F2C CURSOR ENGINES

	Section
General specifications	<b>I</b>
Fuel	<b>2</b>
Industrial application	<b>3</b>
Overhaul and technical specifications	<b>4</b>
Tools	<b>5</b>
Safety prescriptions	<b>Appendix</b>

### PREFACE TO USER'S GUIDELINE MANUAL

Section 1 describes the F2C engine illustrating its features and working in general.

Section 2 describes the type of fuel feed.

Section 3 relates to the specific duty and is divided in four separate parts:

1. Mechanical part, related to the engine overhaul, limited to those components with different characteristics based on the relating specific duty.
2. Electrical part, concerning wiring harness, electrical and electronic equipment with different characteristics based on the relating specific duty.
3. Maintenance planning and specific overhaul.
4. Troubleshooting part dedicated to the operators who, being entitled to provide technical assistance, shall have simple and direct instructions to identify the cause of the major inconveniences.

Sections 4 and 5 illustrate the overhaul operations of the engine overhaul on stand and the necessary equipment to execute such operations.

The appendix contains a list of the general safety regulations to be respected by all installation and maintenance engineers in order to prevent serious accidents taking place.

**<https://www.ebooklibonline.com>**

Hello dear friend!

Thank you very much for reading.

Enter the link into your browser.

The full manual is available for immediate download.

**<https://www.ebooklibonline.com>**



**SPECIAL REMARKS**





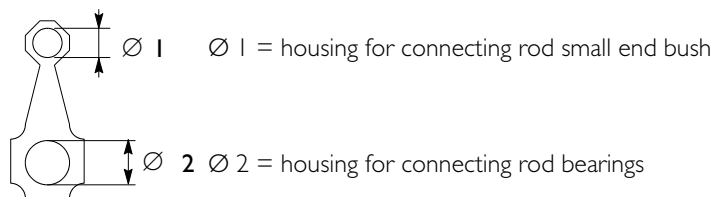

























Diagrams and symbols have been widely used to give a clearer and more immediate illustration of the subject being dealt with, (see next page) instead of giving descriptions of some operations or procedures.

Example



Tighten to torque  
Tighten to torque + angular value

## Graph and symbols

	Removal Disconnection		Intake
	Refitting Connection		Exhaust
	Removal Disassembly		Operation
	Fitting in place Assembly	$\varrho$	Compression ratio
	Tighten to torque		Tolerance Weight difference
	Tighten to torque + angle value		Rolling torque
	Press or caulk		Replacement Original spare parts
	Regulation Adjustment		Rotation
	Warning Note		Angle Angular value
	Visual inspection Fitting position check		Preload
	Measurement Value to find Check		Number of revolutions
	Equipment		Temperature
	Surface for machining Machine finish		Pressure
	Interference Strained assembly	$>$	Oversized Higher than.... Maximum, peak
	Thickness Clearance	$<$	Undersized Less than.... Minimum
	Lubrication Damp Grease		Selection Classes Oversizing
	Sealant Adhesive		Temperature < 0 °C Cold Winter
	Air bleeding		Temperature > 0 °C Hot Summer

**UPDATING**

Section	Description	Page	Date of revision



**SECTION I****General Specifications**

	Page
TECHNICAL CODE .....	3
VIEWS OF THE ENGINE (for types: F2CE9684A*E004 - F2CE9684B*E001 - F2CE9684C*E001 - F2CE9684D*E001 - F2CE9684C*E002 - F2CE9684E*E002) .....	5
VIEWS OF THE ENGINE (for types: F2CE9684L*E005) .....	8
LUBRICATION DIAGRAM .....	11
<input type="checkbox"/> Oil pump .....	12
<input type="checkbox"/> Overpressure valve .....	12
<input type="checkbox"/> Oil pressure control valve .....	13
<input type="checkbox"/> Heat exchanger .....	13
ENGINE OIL FILTER .....	14
<input type="checkbox"/> Characteristics .....	14
<input type="checkbox"/> Lock torques .....	14
<input type="checkbox"/> Installation rule .....	14
<input type="checkbox"/> Filter by-pass valve .....	14
<input type="checkbox"/> Oil fume recycle (Blow-by) .....	15
COOLING .....	16
<input type="checkbox"/> Description .....	16
<input type="checkbox"/> Operation .....	16
<input type="checkbox"/> Water pump .....	18
<input type="checkbox"/> Thermostat .....	18
TURBOCHARGING .....	19
EGR EXHAUST GAS RECYCLE SYSTEM .....	20
INTERNAL EGR OPERATING ON SUCTION VALVES .....	20



**TECHNICAL CODE**

Technical Code
F2CE9684A*E004
F2CE9684B*E001
F2CE9684C*E001
F2CE9684D*E001
F2CE9684C*E002
F2CE9684E*E002
F2CE9684H*E003
F2CE9684L*E005



**VIEWS OF THE ENGINE (for types: F2CE9684A\*E004 - F2CE9684B\*E001 - F2CE9684C\*E001 - F2CE9684D\*E001 - F2CE9684C\*E002 - F2CE9684E\*E002)**

Figure 1

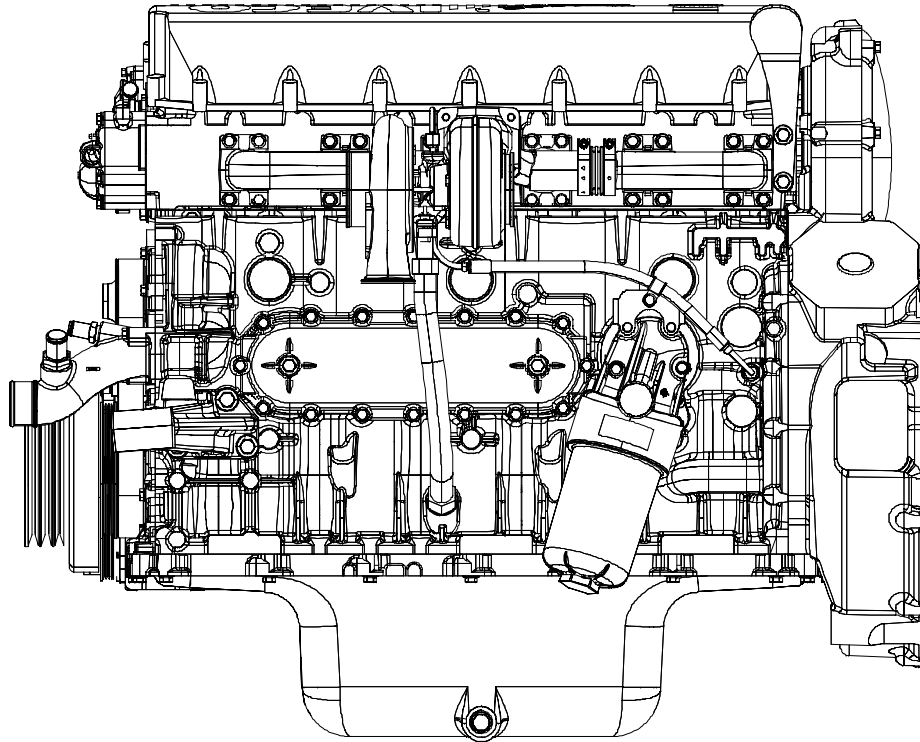

113047

LEFT-HAND SIDE VIEW

Figure 2

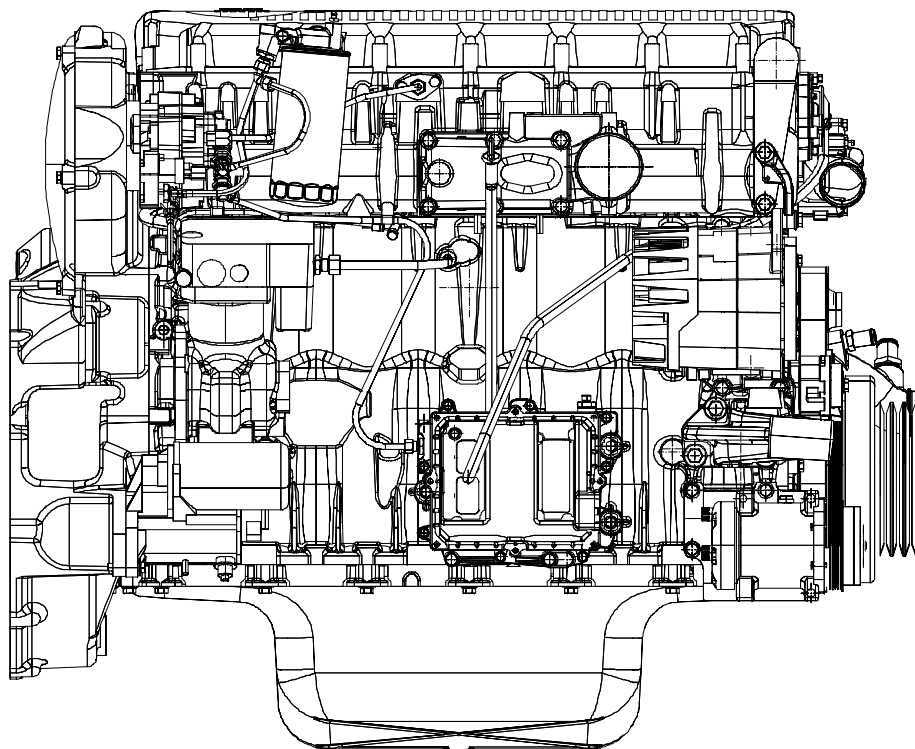

113048

RIGHT-HAND SIDE VIEW

Figure 3

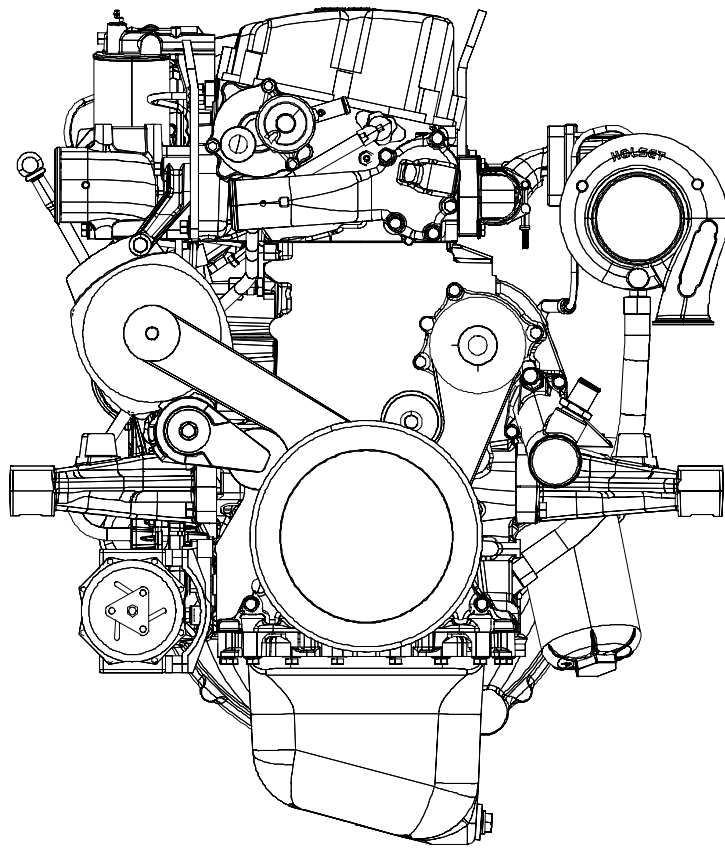

113049

FRONT HAND SIDE VIEW

Figure 4

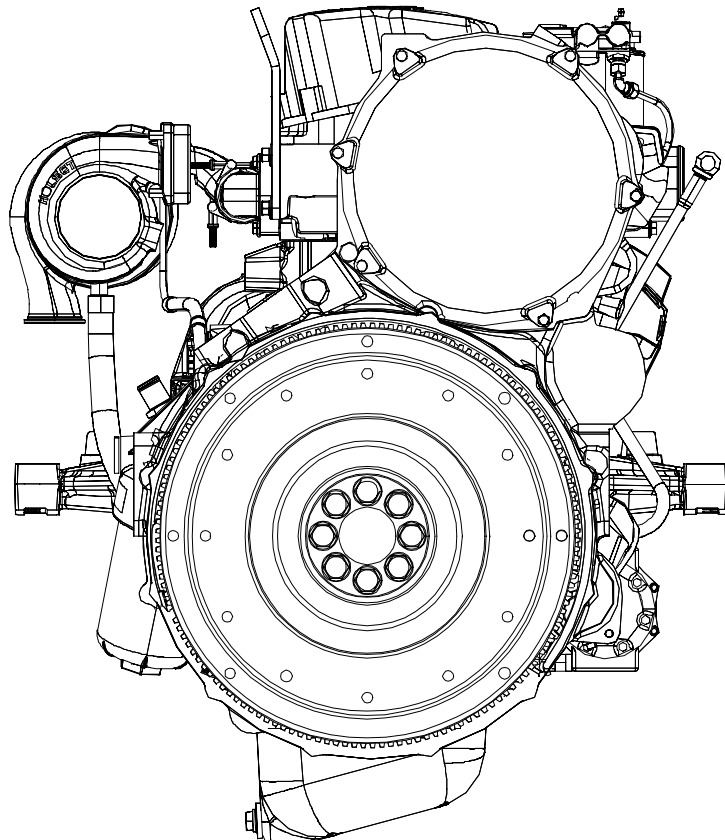

113050

REAR HAND SIDE VIEW

Figure 5

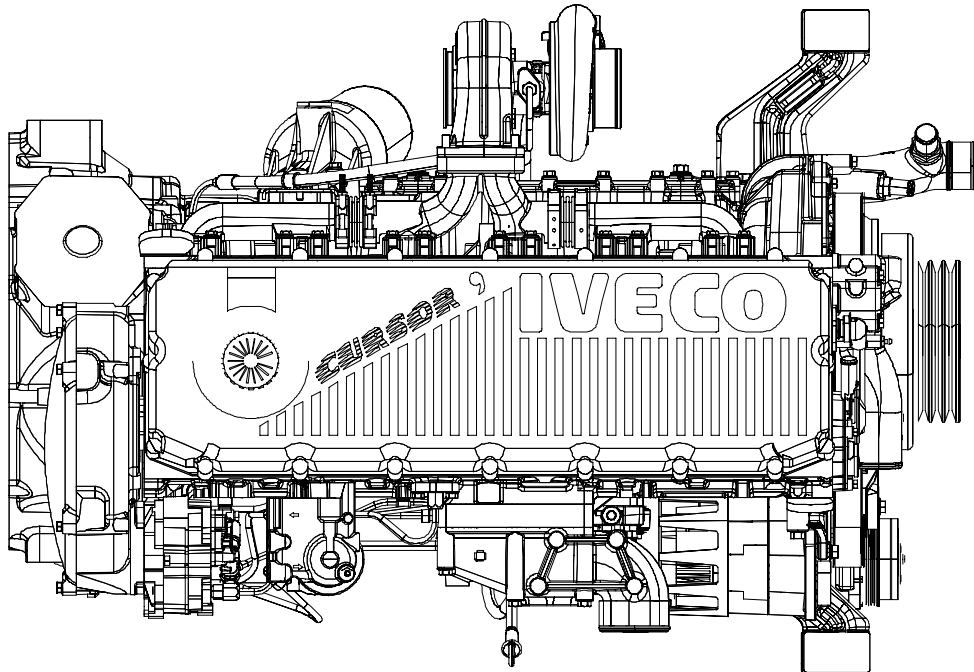

TOP VIEW

113051

**VIEWS OF THE ENGINE (for types: F2CE9684L\*E005)**

Figure 6

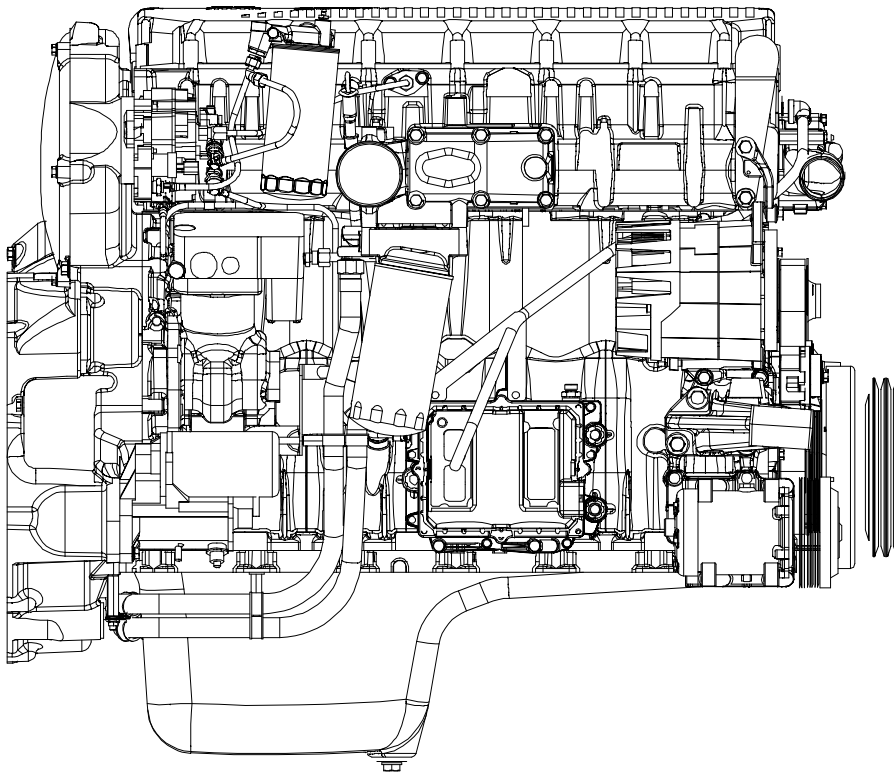

114203

RIGHT-HAND SIDE VIEW

Figure 7

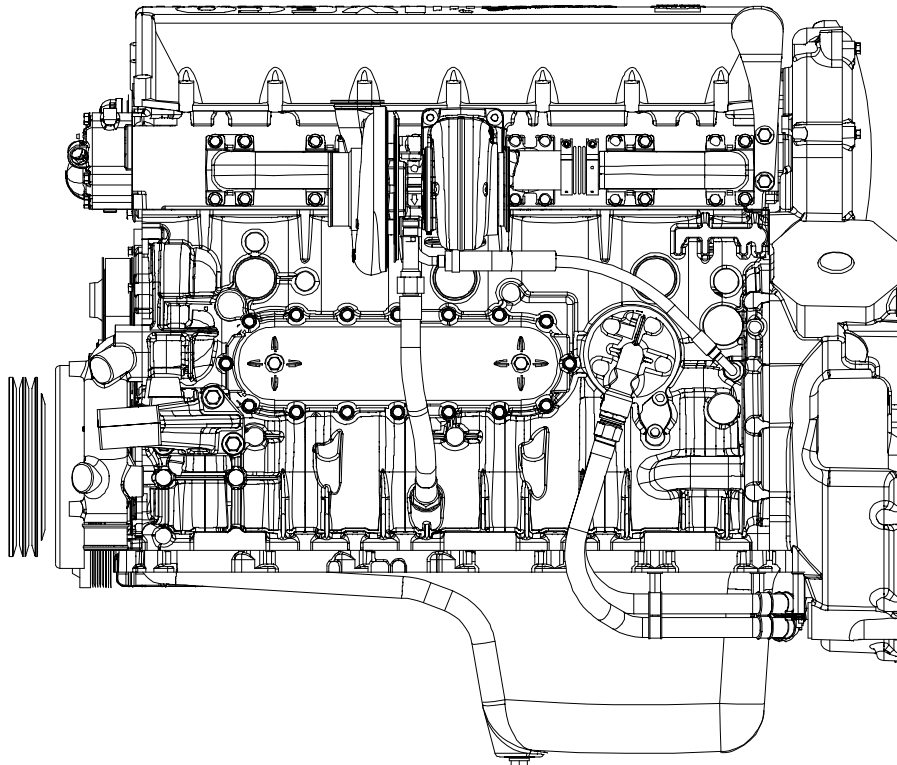

114204

LEFT-HAND SIDE VIEW

Figure 8

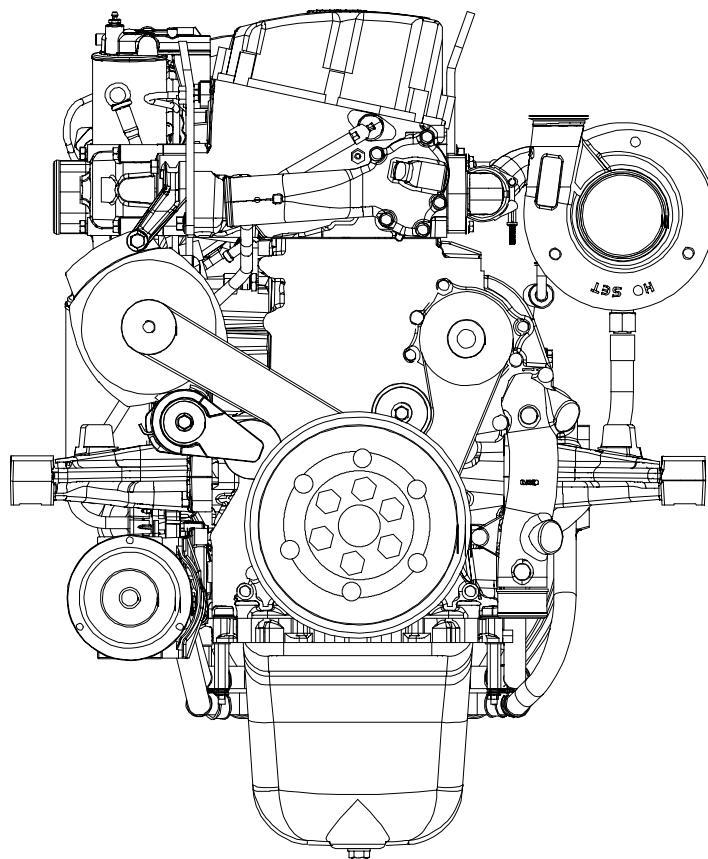

114205

FRONT-HAND SIDE VIEW

Figure 9

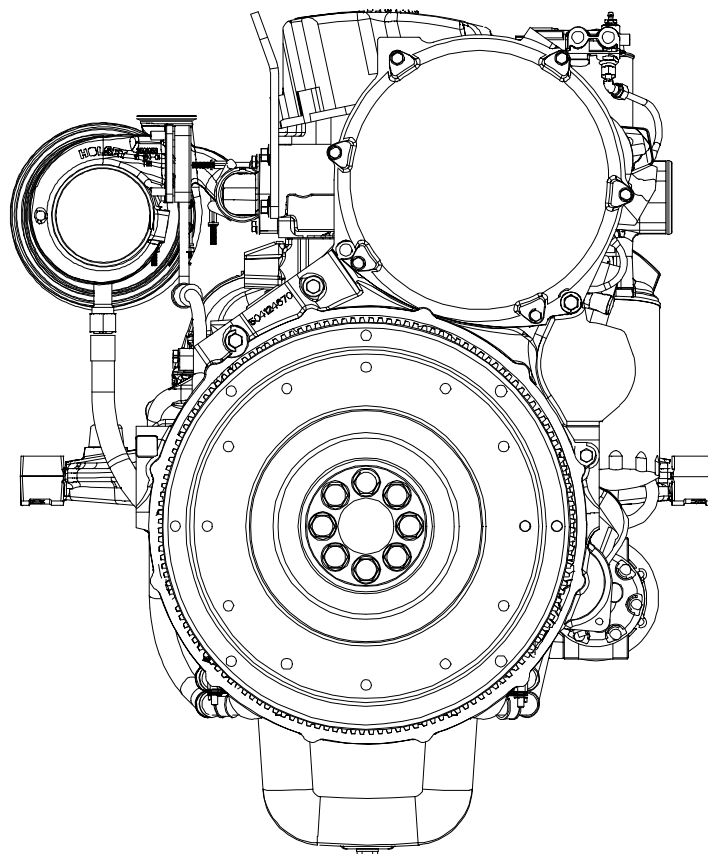

104206

REAR-HAND SIDE VIEW

Figure 10

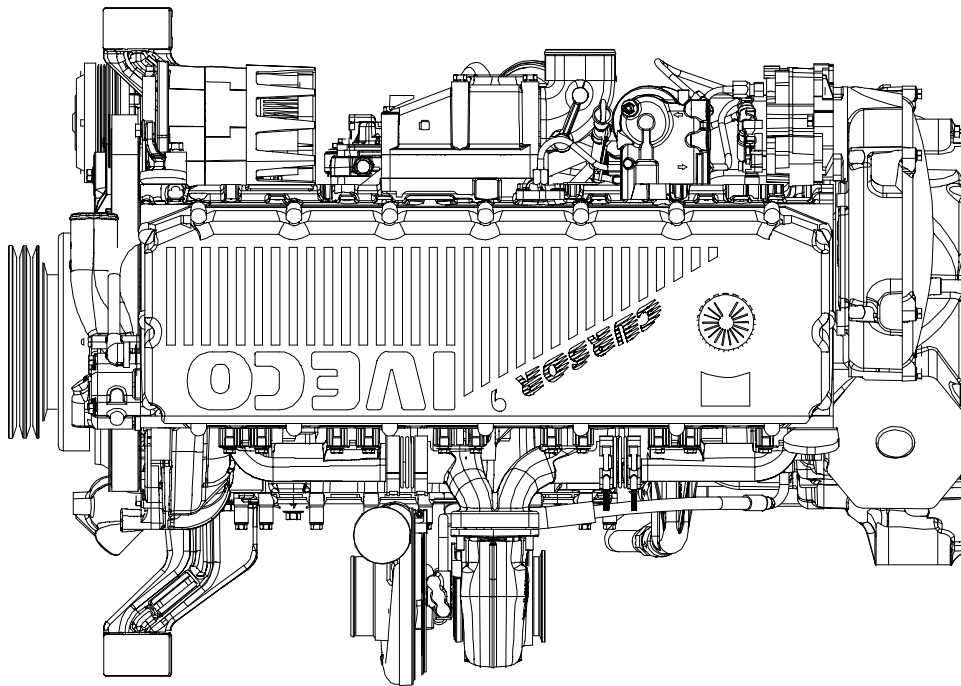

114207

TOP SIDE VIEW

**LUBRICATION DIAGRAM**

**Figure 11**

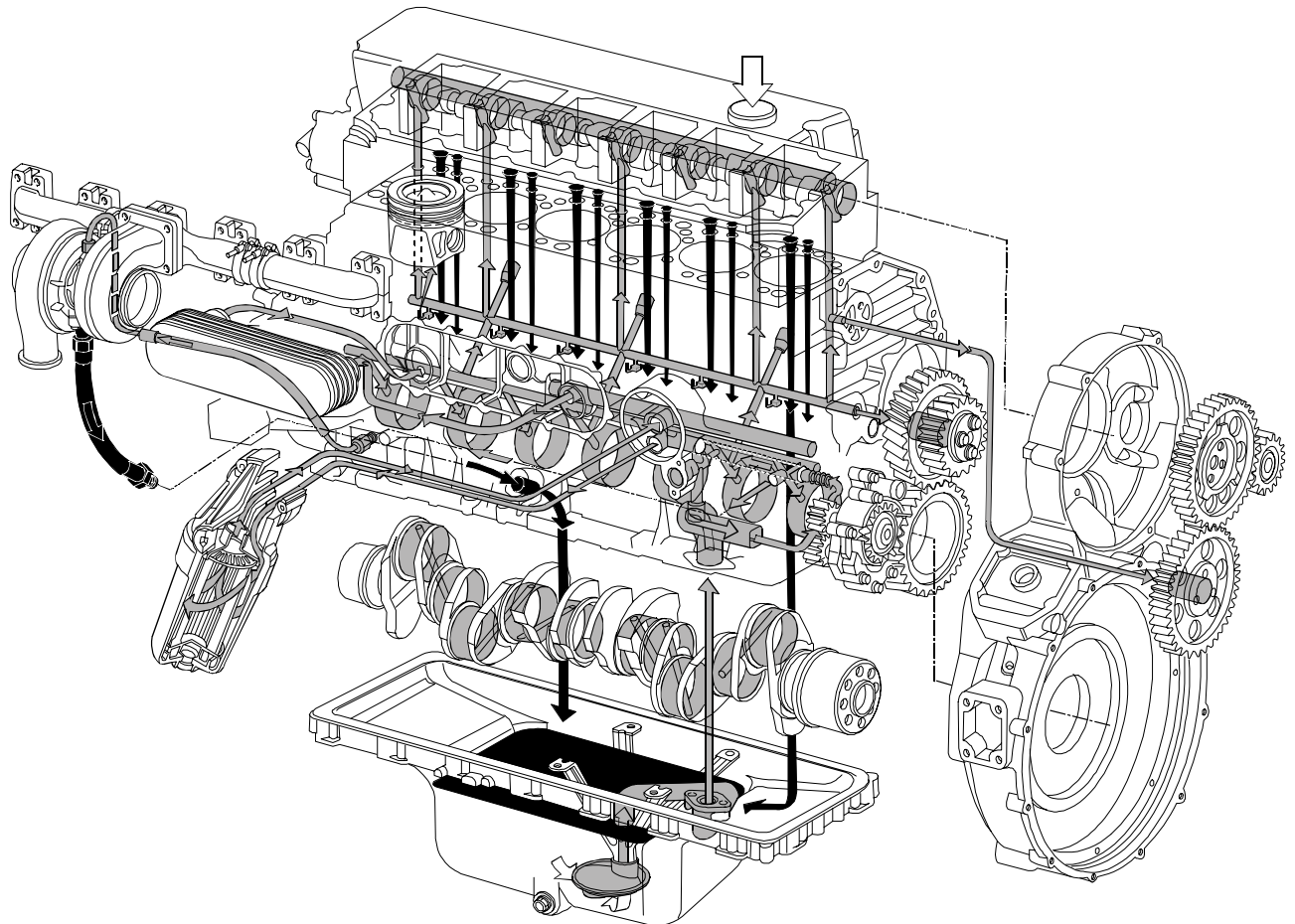

Dropping oil  
 Pressure oil

114244



**Suggest:**

**For more complete manuals. Please go to the home page.**

**<https://www.ebooklibonline.com>**

**If the above button click is invalid. Please download this document first, and then click the above link to download the complete manual.**

**Thank you so much for reading**

**Oil pump**

**Figure 12**

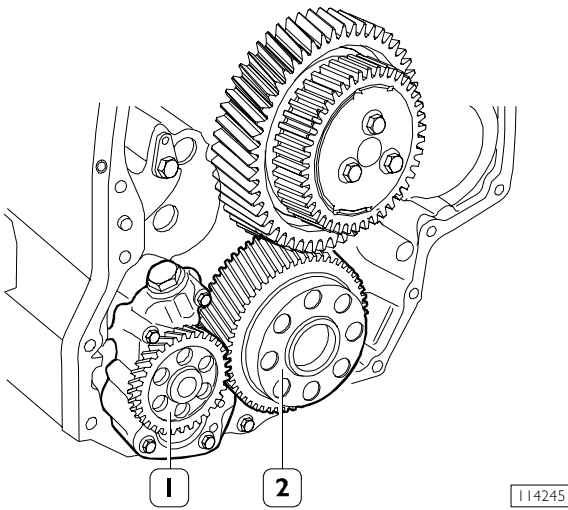

The oil pump (1) cannot be overhauled. On finding any damage, replace the oil pump assembly.  
See under the relevant heading for replacing the gear (2) of the crankshaft.

**Overpressure valve**

**Figure 14**

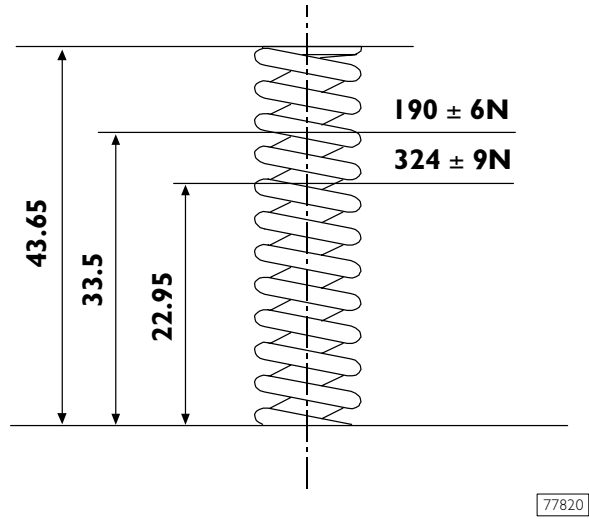

MAIN DATA TO CHECK THE OVERPRESSURE VALVE SPRING

**Figure 13**

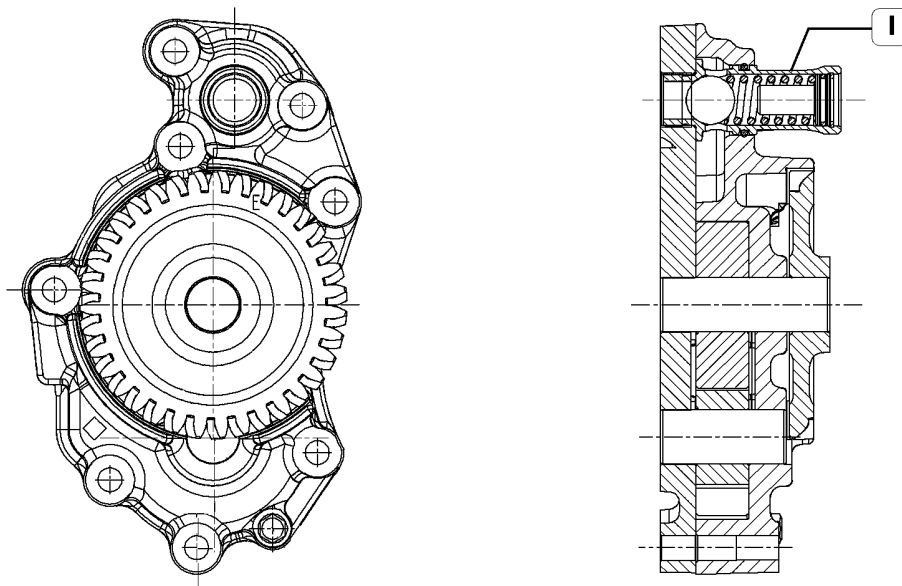

112327

OIL PUMP CROSS-SECTION  
I. Overpressure valve – Start of opening pressure  $10.1 \pm 0.7$  bars.

**Oil pressure control valve**

Figure 15

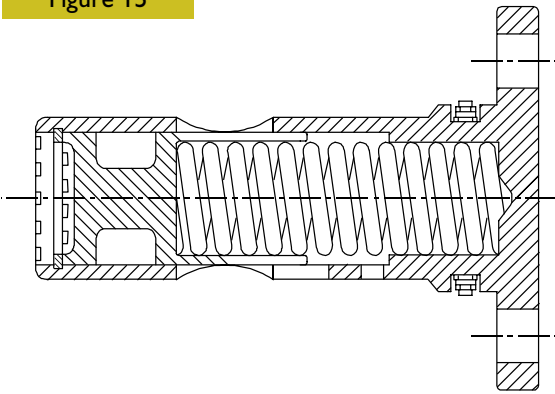

73542

The oil pressure control valve is located on the left-hand side of the crankcase.  
Start of opening pressure 5 bars.

Figure 16

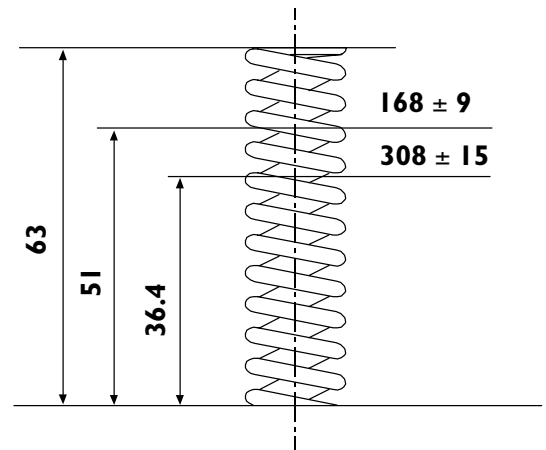

88819

MAIN DATA TO CHECK THE OIL PRESSURE CONTROL VALVE SPRING

**Heat exchanger**

Figure 17

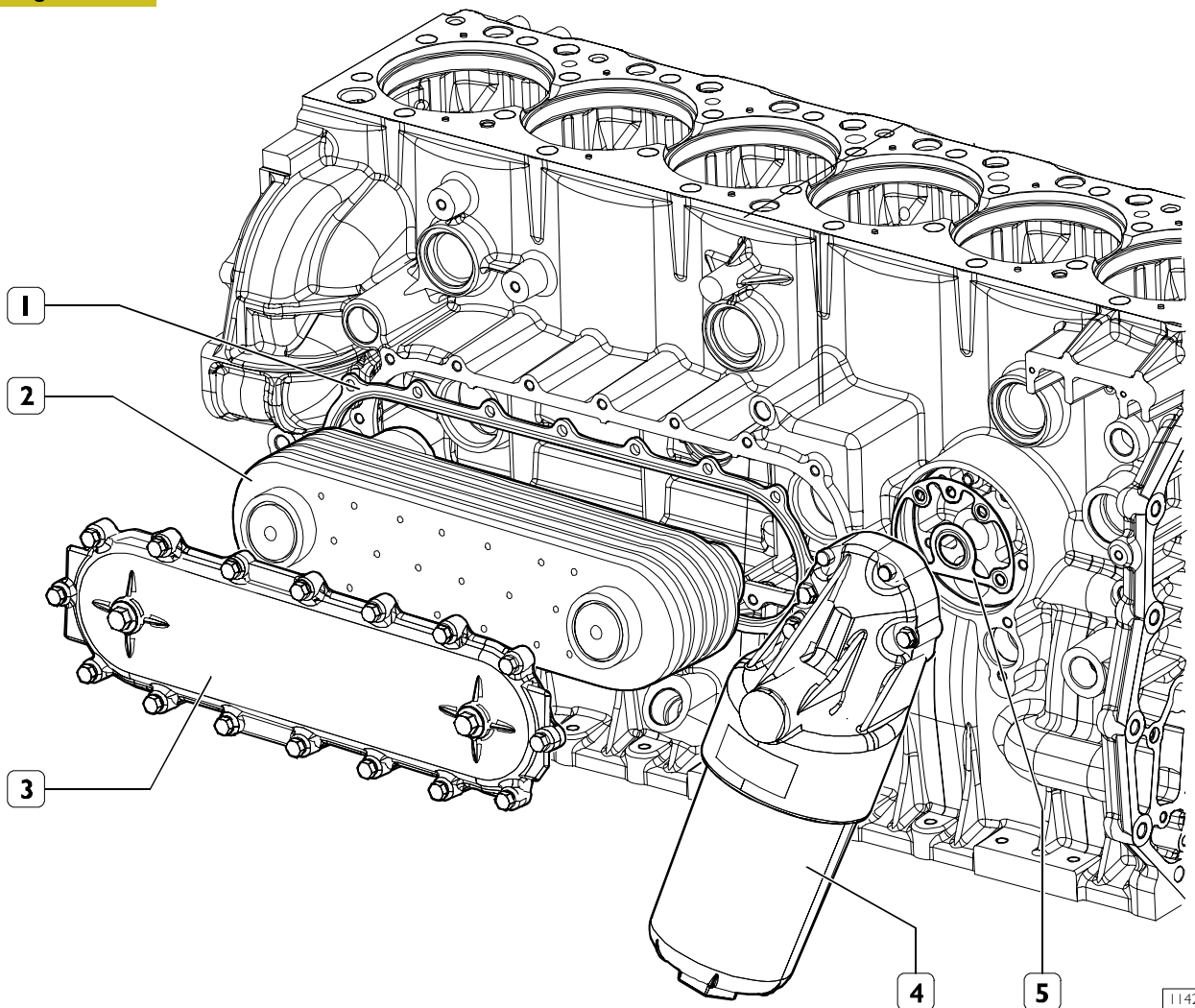

114246

1. Exchanger seal - 2. Internal heat exchanger element - 3. Cover - 4. Oil filter - 5. Oil filter seal

**<https://www.ebooklibonline.com>**

Hello dear friend!

Thank you very much for reading.

Enter the link into your browser.

The full manual is available for immediate download.

**<https://www.ebooklibonline.com>**