

# **CLAAS**



**ELIOS 230-220-210**

## **Operator's manual**

***SERVICE & PARTS***

**VALIDITY OF THE OPERATOR'S MANUAL**

5652

This operator's manual is valid for the following tractors:

Type of tractor	Tractor serial number	
	From	To
ELIOS	A2800001	-

The operator's manual describes the possible equipment for your tractor. Your tractor's equipment is listed in your order confirmation.

**<https://www.ebooklibonline.com>**

Hello dear friend!

Thank you very much for reading.

Enter the link into your browser.

The full manual is available for immediate download.

**<https://www.ebooklibonline.com>**

**UNITS**

6304

The units used in this document are in line with international system of units:

<b><i>Physical</i></b>	<b><i>Unit Name</i></b>	<b><i>Symbol of unity</i></b>	<b><i>Multiples and sub-multiples of the unit</i></b>
Size	Metre	m	mm - cm
Volume	Cubic meter	m <sup>3</sup>	cm <sup>3</sup> - dm <sup>3</sup>
	Liter	l	ml - cl
Angle	Degree	°	
Time	Second	s	
	Minute	min	
	Hour	h	
Linear speed	Kilometer per hour	km/h	m/h
Rotation speed	Revolution per minute	1/min	
Weight	Kilogram	kg	g
Forced	Newton	N	
Torque	Newton meter	Nm	
Pressure	Pascal	Pa	
Power	Watt	W	kW
Flow rate	Liter per minute	l/min	
Temperature	Degree Celsius	°C	
Power voltage	Volt	V	mV
Electric intensity	Ampere	A	mA
Resistor	Ohm	Ω	kΩ
Sound level	Bel	B(A)	dB(A)











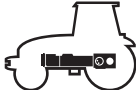

The date format used in this document also complies with the international system:

Year-Month-Day

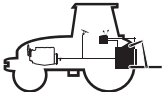
Example: 2010-07-15

## CHAPTER SYMBOLS

5660

REF	CHAPTERS	SYMBOLS
A	IDENTIFICATION - CERTIFICATION - SAFETY	
B	CAB	
C	ELECTRICAL SERVICES	
D	ENGINE	
E	TRANSMISSION	
F	FRONT AXLE	
G	REAR EQUIPMENT	
H	FRONT EQUIPMENT	
J	WHEELS AND TYRES	
K	CHARACTERISTICS	
L	MAINTENANCE	
M	OPERATIONS THAT ARE MANDATORY UNDER THE GUARANTEE	

---

# CONTENTS

## A - IDENTIFICATION - CERTIFICATION - SAFETY

<b>1</b>	<b>TRACTOR INFORMATION PLATE</b> .....	<b>A. 2</b>
<b>2</b>	<b>MOTOR INFORMATION PLATE</b> .....	<b>A. 4</b>
<b>3</b>	<b>FRONT AXLE INFORMATION PLATE</b> .....	<b>A. 5</b>
<b>4</b>	<b>CAB IDENTIFICATION PLATE</b> .....	<b>A. 6</b>
<b>5</b>	<b>EUROPEAN REGULATION</b> .....	<b>A. 7</b>
<b>6</b>	<b>SAFETY</b> .....	<b>A. 8</b>
6.1	SAFETY INSTRUCTIONS .....	A. 8
6.2	SAFETY STICKERS WITH WARNING PICTOGRAMS .....	A. 23

## B - DRIVING POSITION

### CAB

<b>1</b>	<b>OPERATING AND WORKING ENVIRONMENT</b> .....	<b>B. 4</b>
1.1	RIGHT SIDE CONTROLS .....	B. 4
1.2	LEFT SIDE CONTROLS .....	B. 4
1.3	INSTRUMENTS AND CONTROLS (PANEL) .....	B. 5
1.4	STOWAGE AND ACCESSORIES .....	B. 6
<b>2</b>	<b>LIGHTING, INDICATORS AND SAFETY</b> .....	<b>B. 8</b>
2.1	DESCRIPTION .....	B. 8
2.2	LOW/HIGH BEAMS AND HORN .....	B. 11
2.3	ADJUSTMENT OF DIPPED LIGHTS .....	B. 12
2.4	WORKING LIGHTS AND ROTATING BEACON .....	B. 13
2.5	OVERHEAD LIGHT .....	B. 14
2.6	REAR VIEW MIRRORS .....	B. 14
<b>3</b>	<b>STARTING CONTACT</b> .....	<b>B. 16</b>
<b>4</b>	<b>DRIVER'S SEAT</b> .....	<b>B. 17</b>
<b>5</b>	<b>STEERING WHEEL</b> .....	<b>B. 19</b>
<b>6</b>	<b>INSTRUMENT PANEL</b> .....	<b>B. 20</b>
6.1	DESCRIPTION .....	B. 20
6.2	OPERATION .....	B. 21
6.3	OPERATION .....	B. 24
6.4	PARAMETERISATION .....	B. 25

<b>7</b>	<b>HINGED PANELS AND WINDOWS</b> .....	<b>B. 29</b>
<b>8</b>	<b>SIGHT</b> .....	<b>B. 32</b>
<b>9</b>	<b>HEATING - VENTILATION - MANUAL AIR CONDITIONING</b> .....	<b>B. 33</b>
9.1	DESCRIPTION .....	B. 33
9.2	OPERATION .....	B. 34

## **PLATFORM**

<b>1</b>	<b>OPERATING AND WORKING ENVIRONMENT</b> .....	<b>B. 38</b>
1.1	RIGHT SIDE CONTROLS .....	B. 38
1.2	LEFT SIDE CONTROLS .....	B. 38
1.3	INSTRUMENTS AND CONTROLS (PANEL) .....	B. 39
<b>2</b>	<b>LIGHTING, INDICATORS AND SAFETY</b> .....	<b>B. 40</b>
2.1	DESCRIPTION .....	B. 40
2.2	LOW/HIGH BEAMS AND HORN .....	B. 42
2.3	ADJUSTMENT OF DIPPED LIGHTS .....	B. 42
2.4	WORKING LIGHTS AND ROTATING BEACON .....	B. 42
2.5	REAR VIEW MIRRORS .....	B. 43
<b>3</b>	<b>STARTING CONTACT</b> .....	<b>B. 44</b>
<b>4</b>	<b>DRIVER'S SEAT</b> .....	<b>B. 45</b>
<b>5</b>	<b>STEERING WHEEL</b> .....	<b>B. 46</b>
<b>6</b>	<b>INSTRUMENT PANEL</b> .....	<b>B. 47</b>
<b>7</b>	<b>FOLDING ROLL BAR</b> .....	<b>B. 48</b>

## **C - ELECTRICAL SYSTEM**

<b>1</b>	<b>CHARACTERISTICS</b> .....	<b>C. 2</b>
<b>2</b>	<b>TRAILER/IMPLEMENT LIGHT SOCKET</b> .....	<b>C. 3</b>
<b>3</b>	<b>ELECTRIC CABINET SUPPLY SOCKET</b> .....	<b>C. 4</b>
<b>4</b>	<b>BATTERY</b> .....	<b>C. 5</b>
<b>5</b>	<b>FUSES AND RELAYS</b> .....	<b>C. 7</b>
5.1	RECOMMENDATIONS .....	C. 7
5.2	FUSE BOX UNDER THE DASHBOARD .....	C. 7
5.3	ENGINE COMPARTMENT FUSE BOX .....	C. 8
5.4	MAIN FUSE AND RELAY BOX .....	C. 9
5.5	RIGHT-HAND POST FUSE BOX .....	C. 12
5.6	LEFT POST RELAYS .....	C. 12
5.7	FUSES AND RELAYS OF THE ELECTRO-HYDRAULIC VALVES .....	C. 13

## **D - ENGINE**

<b>1</b>	<b>CHARACTERISTICS</b> .....	<b>D. 2</b>
<b>2</b>	<b>DISPLAYS</b> .....	<b>D. 4</b>
2.1	INSTRUMENT PANEL .....	D. 4

---

<b>3</b>	<b>SAFETY</b> .....	<b>D. 5</b>
3.1	INSTRUMENT PANEL .....	D. 5
3.2	RECOMMENDATIONS .....	D. 5
<b>4</b>	<b>ENGINE HOOD</b> .....	<b>D. 6</b>
4.1	ONE-PIECE HOOD .....	D. 6
4.2	SIDE PANELS .....	D. 6
<b>5</b>	<b>ENGINE CONTROL</b> .....	<b>D. 8</b>
5.1	STARTING THE ENGINE .....	D. 8
5.2	USING THE ACCELERATOR PEDAL AND LEVER .....	D. 10
5.3	STOPPING THE ENGINE .....	D. 11
<b>6</b>	<b>FUEL</b> .....	<b>D. 13</b>
6.1	RECOMMENDATIONS .....	D. 13
6.2	BLEEDING AIR FROM THE INJECTION SYSTEM .....	D. 14

## **E - TRANSMISSION**

### **GEARBOX**

<b>1</b>	<b>CHARACTERISTICS</b> .....	<b>E. 4</b>
<b>2</b>	<b>FORWARD SPEEDS</b> .....	<b>E. 6</b>
<b>3</b>	<b>DISPLAY</b> .....	<b>E. 10</b>
3.1	INSTRUMENT PANEL .....	E. 10
<b>4</b>	<b>SAFETY</b> .....	<b>E. 11</b>
4.1	REVERSER NEUTRAL .....	E. 11
<b>5</b>	<b>STARTING THE TRACTOR</b> .....	<b>E. 13</b>
5.1	CLUTCH .....	E. 13
5.2	SELECTION OF MOVEMENT DIRECTION .....	E. 14
5.3	GEAR SELECTION .....	E. 15
5.4	DOUBLER .....	E. 15
5.5	RANGE SELECTION .....	E. 16

### **REAR AXLE**

<b>1</b>	<b>CHARACTERISTICS</b> .....	<b>E. 18</b>
<b>2</b>	<b>PROTECTION OF MECHANICAL PARTS</b> .....	<b>E. 19</b>
<b>3</b>	<b>DIFFERENTIAL LOCK</b> .....	<b>E. 20</b>
3.1	RECOMMENDATIONS .....	E. 20
3.2	OPERATION .....	E. 20
<b>4</b>	<b>BRAKES</b> .....	<b>E. 21</b>
4.1	SERVICE BRAKES .....	E. 21
4.2	PARKING BRAKE .....	E. 21
<b>5</b>	<b>TRAILER BRAKE</b> .....	<b>E. 23</b>
5.1	HYDRAULIC BRAKE .....	E. 23

---

## F - FRONT AXLE

<b>1</b>	<b>CHARACTERISTICS .....</b>	<b>F. 2</b>
<b>2</b>	<b>FRONT/REAR INTER-AXLE RATIO .....</b>	<b>F. 4</b>
<b>3</b>	<b>FRONT AXLE ENGAGEMENT .....</b>	<b>F. 5</b>
3.1	GENERAL .....	F. 5
3.2	AUTOMATIC MODE .....	F. 5
3.3	PERMANENT MODE .....	F. 6

## G - REAR EQUIPMENT

### HYDRAULIC SYSTEMS

<b>1</b>	<b>CHARACTERISTICS .....</b>	<b>G. 4</b>
<b>2</b>	<b>MECHANICAL COMMAND AUXILIARY VALVES .....</b>	<b>G. 7</b>
2.1	ASSOCIATION BETWEEN CONTROLS/REAR PRESSURE CONNECTORS .....	G. 7
2.2	PRESSURE CONNECTORS .....	G. 8
2.3	DUAL ACTING/SINGLE ACTING CONVERSION .....	G. 9
<b>3</b>	<b>ELECTROHYDRAULIC SPOOL VALVES .....</b>	<b>G. 10</b>
3.1	ASSOCIATION BETWEEN CONTROLS/REAR PRESSURE CONNECTORS .....	G. 10
3.2	PRESSURE CONNECTORS .....	G. 10
3.3	CONTROLS .....	G. 12
3.4	START UP .....	G. 12
3.5	LINEAR CONTROLS .....	G. 13
3.6	JOYSTICK .....	G. 14
3.7	FLOW ADJUSTMENTS .....	G. 14
3.8	HYDRAULIC TIMER .....	G. 15
<b>4</b>	<b>STATIONARY WORKING .....</b>	<b>G. 17</b>

### REAR LIFT

<b>1</b>	<b>MECHANICAL LINKAGE .....</b>	<b>G. 20</b>
1.1	CHARACTERISTICS .....	G. 20
1.2	CONTROLS .....	G. 21
1.3	POSITION CONTROL .....	G. 21
1.4	FORCE CONTROL .....	G. 22
1.5	MIXED CONTROL .....	G. 22
1.6	FLOATING LINKAGE .....	G. 23
1.7	EXTERNAL CONTROLS .....	G. 24
1.8	SENSITIVITY .....	G. 24

---

<b>2</b>	<b>ELECTRO-HYDRAULIC LIFTING TCE6 .....</b>	<b>G. 26</b>
2.1	CHARACTERISTICS .....	G. 26
2.2	CONTROLS .....	G. 27
2.3	SAFETY .....	G. 28
2.4	USING THE LINKAGE .....	G. 29
2.5	MODE SELECTION .....	G. 30
2.6	POSITION CONTROL .....	G. 30
2.7	FORCE CONTROL .....	G. 31
2.8	UPPER LIMIT .....	G. 32
2.9	LOWERING SPEED .....	G. 33
2.10	"RAPID ENTRY" FUNCTION .....	G. 34
2.11	EXTERNAL CONTROLS .....	G. 35

---

## REAR POWER TAKE-OFF

1	CHARACTERISTICS .....	G. 38
2	RECOMMENDATIONS .....	G. 39
3	OPERATION .....	G. 40
4	DISPLAY .....	G. 42
5	PTO SPEED SELECTION .....	G. 43
6	SELECTING GROUND-SPEED POWER TAKE-OFF .....	G. 44
7	CONNECTING IMPLEMENTS TO THE POWER TAKE-OFF .....	G. 45
8	STATIONARY WORKING .....	G. 46

## REAR HITCH

1	CHARACTERISTICS .....	G. 48
2	RECOMMENDATIONS .....	G. 50
3	ADJUSTABLE LINKS .....	G. 52
4	UPPER LINK .....	G. 53
5	AUTOMATIC HOOKS .....	G. 54
6	MECHANICAL STABILISERS .....	G. 56
7	DRAW BAR COUPLINGS .....	G. 57
8	SWINGING DRAWBAR .....	G. 59
9	AUTOMATIC PICK-UP HITCH .....	G. 61

## H - FRONT EQUIPMENT

### FRONT LINKAGE

1	CHARACTERISTICS .....	H. 4
2	FRONT LINKAGE CONTROLLED BY SPOOL VALVE 2 .....	H. 5
2.1	CONTROLS .....	H. 5
2.2	PRELIMINARY OPERATIONS .....	H. 6
2.3	OPERATION .....	H. 8
3	3-POINT HITCH .....	H. 11
3.1	LOWER LINKS .....	H. 11
3.2	UPPER LINK .....	H. 12
3.3	HITCHING AND UNHITCHING THE TOOL .....	H. 13

---

## FRONT POWER TAKE-OFF

1	CHARACTERISTICS .....	H. 16
2	RECOMMENDATIONS .....	H. 17
3	FRONT POWER TAKE-OFF ENGAGEMENT .....	H. 18
4	STOP OF THE FRONT POWER TAKE-OFF .....	H. 20

## FRONT LOADER

1	FITTING A FRONTAL LOADER ADAPTATION FRAME .....	H. 22
2	OPERATION .....	H. 24

## J - WHEELS AND TYRES

1	TYRES .....	J. 2
1.1	RECOMMENDATIONS .....	J. 2
1.2	INFLATION PRESSURE .....	J. 2
1.3	LOAD INDEX .....	J. 4
1.4	SPEED CODE .....	J. 5
2	TRACK WIDTHS .....	J. 6
2.1	SETTING THE TRACK .....	J. 6
2.2	FRONT TRACKS .....	J. 8
2.3	REAR TRACKS .....	J. 14
2.4	TYRE COMBINATIONS .....	J. 17

## K - CHARACTERISTICS

1	DIMENSIONS .....	K. 2
1.1	CAB .....	K. 2
1.2	PLATFORM .....	K. 4
2	WEIGHT .....	K. 6
2.1	CAB .....	K. 6
2.2	PLATFORM .....	K. 6
3	LOAD-BEARING CAPABILITIES .....	K. 7
4	MAXIMUM TOW WEIGHT AUTHORIZED .....	K. 8
5	CAPACITIES .....	K. 9
6	BALLAST .....	K. 11
6.1	BALLASTING AVAILABLE .....	K. 11
6.2	TRACTOR BALANCING .....	K. 12
6.3	COMPATIBILITY OF WEIGHTS WITH THE TIRES .....	K. 14
7	CAB COMFORT .....	K. 15
7.1	SOUND LEVEL .....	K. 15
7.2	VIBRATION LEVEL .....	K. 16

---

## **L - MAINTENANCE**

<b>1</b>	<b>RECOMMENDATIONS .....</b>	<b>L. 2</b>
<b>2</b>	<b>TOWING .....</b>	<b>L. 9</b>
<b>3</b>	<b>TRANSPORT .....</b>	<b>L. 10</b>
<b>4</b>	<b>USING A JACK .....</b>	<b>L. 11</b>
<b>5</b>	<b>REPLACING A WHEEL .....</b>	<b>L. 13</b>
<b>6</b>	<b>LOADING AND STOWING THE TRACTOR .....</b>	<b>L. 14</b>
<b>7</b>	<b>STORAGE .....</b>	<b>L. 15</b>
<b>8</b>	<b>DECOMMISSIONING AND DESTRUCTION .....</b>	<b>L. 17</b>
<b>9</b>	<b>FREQUENCIES .....</b>	<b>L. 18</b>
9.1	SUMMARY TABLE .....	L. 18
9.2	OPERATIONS .....	L. 22
<b>10</b>	<b>BLEEDING AIR FROM THE INJECTION SYSTEM .....</b>	<b>L. 62</b>
<b>11</b>	<b>MAINTENANCE LOGBOOK .....</b>	<b>L. 63</b>

## **M - OPERATIONS THAT ARE MANDATORY UNDER THE GUARANTEE**

<b>1</b>	<b>OPERATIONS MANDATORY UNDER THE TERMS OF THE CONTRACTUAL GUARANTEE .....</b>	<b>M. 2</b>
1.1	PRE-DELIVERY INSPECTION .....	M. 2
1.2	HANDING OVER TO THE CUSTOMER .....	M. 2
1.3	MANDATORY ROUTINE MAINTENANCE .....	M. 2
1.4	MANDATORY INSPECTIONS .....	M. 3

# A - IDENTIFICATION - CERTIFICATION - SAFETY





## 1 TRACTOR INFORMATION PLATE

6604

In all correspondence or orders, please do not omit to mention the tractor's identification number, the type and serial number of the engine.

The plate (1) is riveted to the front face of the radiator bracket.

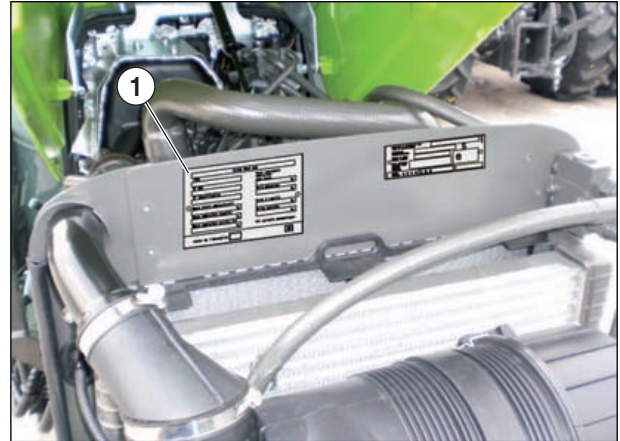

872vm01d

	<b>Type :</b>
	<b>Vehicle identification number:</b>

- A – Tractor type.
- B – Reception number per CE type.
- C – Tractor ID number.
- D – Maximum total weight acceptable loaded according to the tires (kg).
- E – Maximum front axle loaded weight depending on tyre fit (kg).
- F – Maximum rear axle loaded weight depending on tyre fit (kg).
- G – Maximum unbraked trailer weight (kg).
- H – Maximum trailer weight - mechanical brake (kg).
- I – Maximum trailer weight - inertia brake (kg).
- J – Maximum trailer weight - servo brake (kg).
- K – Smoke absorption coefficient.

A	CLAAS KGaA mbH		
	TYPE		Masse remorque admissible sans frein
B	N° CEE		kg
C	N° identification		frein mécanique kg
D	Masse totale admissible(*)		frein à inertie kg
E	Masse admissible avant(*)		freins assistés kg
F	Masse admissible arrière (*)		(*) solvants pneumatiques
K	valeur de l'absorption		

872vm03d



The tractor's identification number (C) is composed of the regulation type (1) and serial number (2) of the tractor (the example given opposite is completely fictitious).

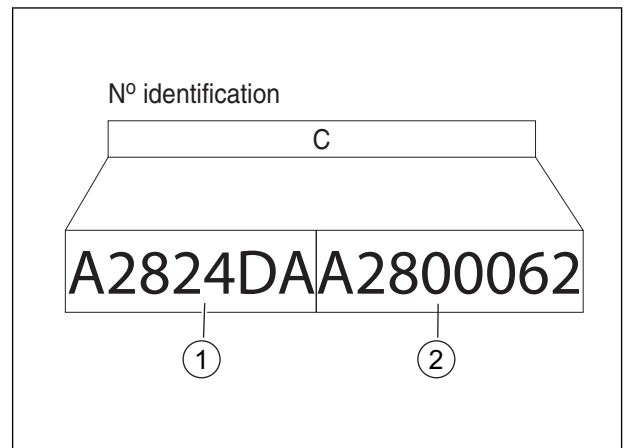

841hsn10m

### Tractor regulation type

The regulation type (1) is broken down in the following manner:

Type of tractor	Engine power code	Number of drive wheels	Cabin type	Maximum tractor speed
A28	0: ELIOS 210 1: ELIOS 220 2: ELIOS 230	2: 2 wheel drive 4: 4 wheel drive	A: Platform D: Classic cab	A: 40 km/h B: 30 km/h M: 40 km/h * N: 30 km/h *

\* Gross vehicle weight restricted to 3 500 kg

### Tractor serial number

The tractor's serial number (2) is composed of the tractor type "A28" followed by a 5 digit number.



## 2 MOTOR INFORMATION PLATE

6605

### Motor information plate:

The identification plate of the engine (1) is located on the left-hand side of the engine.

This plate contains the engine type and serial number.

This label provides information on the engine (Manufacturer data).

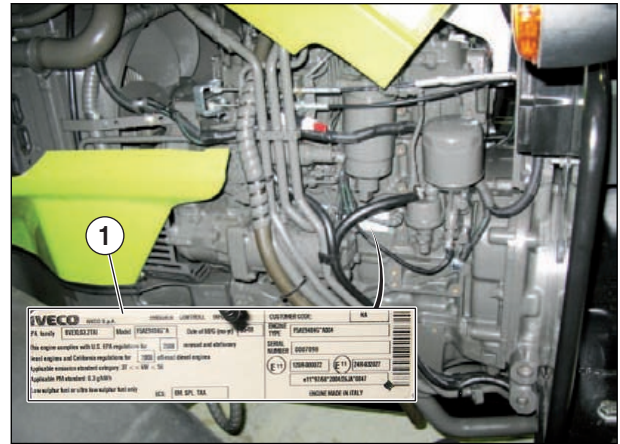

103vfn09d

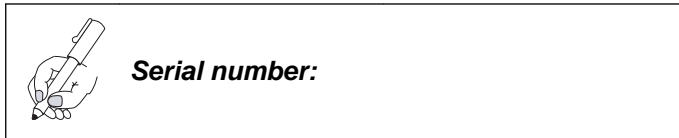
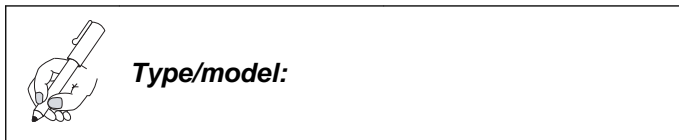

A – Type .

B – Serial number.

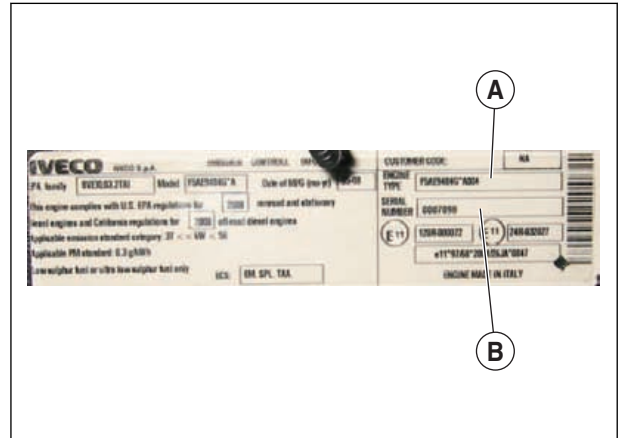

103vfn13d



## 3 FRONT AXLE INFORMATION PLATE

6618

The front axle identification plate (1) is located on the right side of the front axle.

This plate indicates the type and serial number of the front axle.

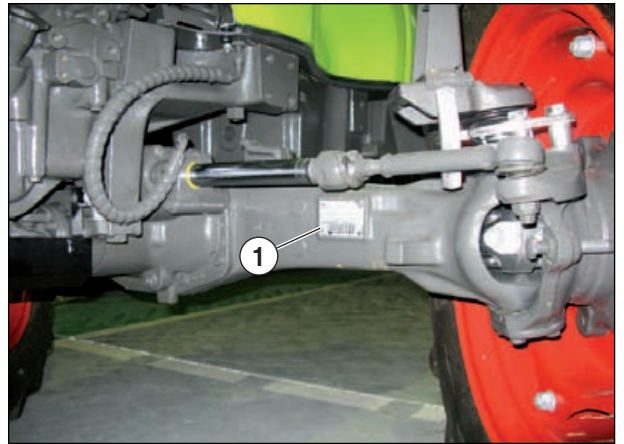

454vfn23d

	<b>Type/model:</b>
	<b>Serial number:</b>

Front axle (4-4-wheel drive tractor):

- A – Type .
- B – Serial number.
- C – Reference.
- D – Overall reduction ratio.
- E – Oil type.
- F – Oil capacity of epicyclic reduction gear (l).
- G – Oil capacity of differential housing (l).

AXLE TYPE		SERIAL N.		
○	A	B	◎	
CARRARO N.	CUSTOMER N.	TOTAL RATIO		
C	-----	D		
INPUT ROTATION		DIFFERENTIAL TYPE		MADE IN ITALY
OIL SPECIFICATION		LOCAT.	LIT.	
E		DIFF. F		
		EPIC. G		
◎			◎	

454vfn24d

Undriven front axle (2-4-wheel drive tractor):

- A – Reference.
- B – Serial number.

CARRARO N°.			
○	A	CUSTOMER N°.	◎
SERIAL N°.	B	XXXXX	
MADE IN ITALY			

454vfn25d



**Suggest:**

**For more complete manuals. Please go to the home page.**

**<https://www.ebooklibonline.com>**

**If the above button click is invalid. Please download this document first, and then click the above link to download the complete manual.**

**Thank you so much for reading**



## 4 CAB IDENTIFICATION PLATE

6606

The plate (1) is riveted to the front face of the radiator bracket.

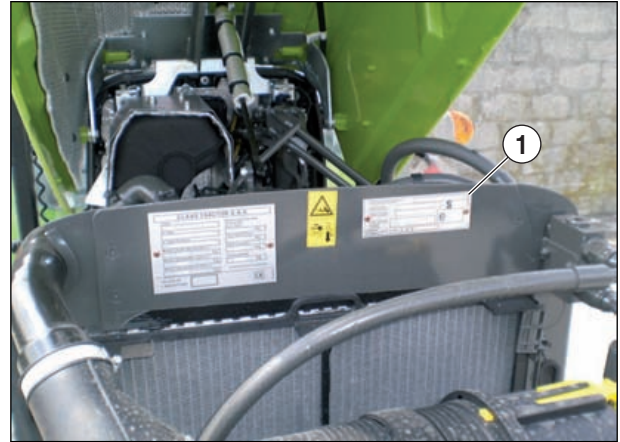

872vfn11

- A – Reception number per EMC type (Electromagnetic compatibility).
- B – Absorption ratio.
- C – Homologation number per cab type.

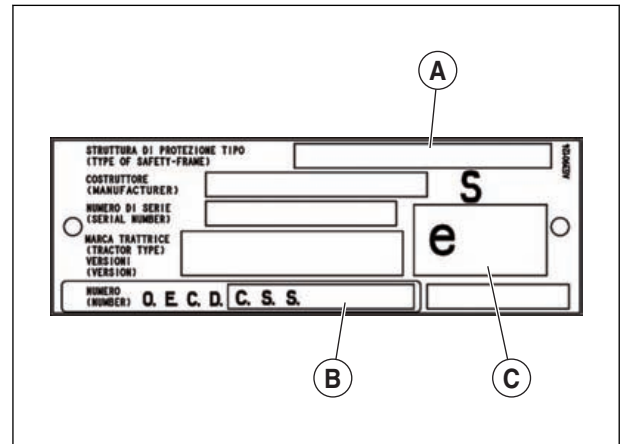

872vfn04d



## 5 EUROPEAN REGULATION

6552

CLAAS tractors put in circulation in the European Community meet modified European Directive 2003/37. A certificate of conformity is supplied when each tractor is delivered. Hence, the tractor's manufacturer ensures conformance of the tractor with the CE directive mentioned previously upon initial marketing.

In countries outside the European Union, apply the appropriate national provisions.

**<https://www.ebooklibonline.com>**

Hello dear friend!

Thank you very much for reading.

Enter the link into your browser.

The full manual is available for immediate download.

**<https://www.ebooklibonline.com>**