

Previous Screen

Product: TRACK-TYPE TRACTOR

Model: D5B TRACK-TYPE TRACTOR 47X

Configuration: D5B TRACK-TYPE TRACTOR / DIRECT DRIVE / 47X00520-UP (MACHINE) POWERED BY 3306 ENGINE

**Disassembly and Assembly  
SUPPLEMENT FOR 3300 SERIES NEW SCROLL FUEL SYSTEMS**

Media Number -SEN5511-00

Publication Date -01/01/1992

Date Updated -12/10/2001

## Governor

SMCS - 1264-015; 1264-016

### Disassemble Governor

Tools Needed		A	B	C
1P510	Driver Group	1		
6V2163	Clamp Assembly-Spring Compressor		1	
1P1855	Snap Ring Pliers			1

Start By:

- a. remove fuel injection pump housing and governor

**NOTE:** To remove the governor for fuel injection pump housing disassembly, perform Steps 1, 15, 21, 25-28, 31, 33, 34 and 37.

---

#### NOTICE

**Keep all parts clean from contaminants. Contaminants put into the system may cause rapid wear and shortened component life.**

---

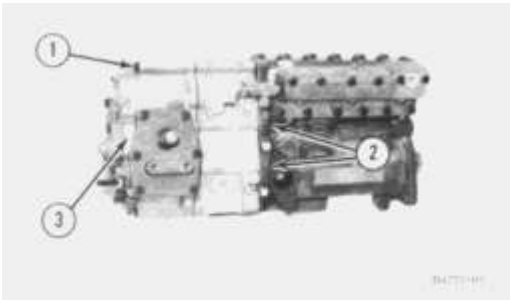

This illustration shows the fuel shutoff solenoid and tachometer adapter removed.

1. Remove six bolts (1), two top bolts (2), housing (3) and the gasket.

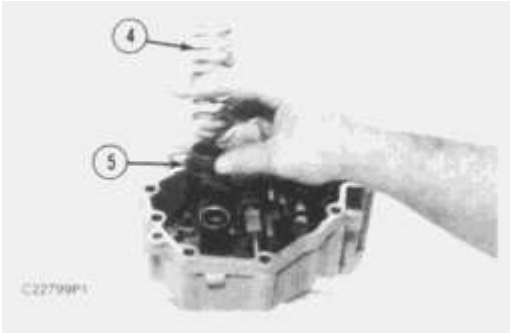

2. Remove governor spring (4) and seat (5).

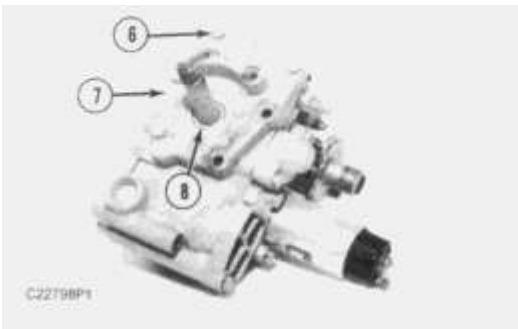

3. Remove bolts (6), cover (7) and the gasket. Use tool (A) to remove seal (8).

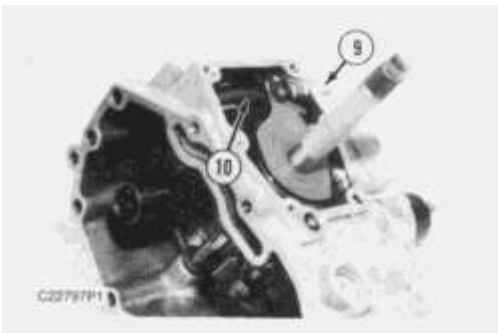

4. Remove low idle adjustment screw (9) and spring (10).

**<https://www.ebooklibonline.com>**

Hello dear friend!

Thank you very much for reading.

Enter the link into your browser.

The full manual is available for immediate download.

**<https://www.ebooklibonline.com>**

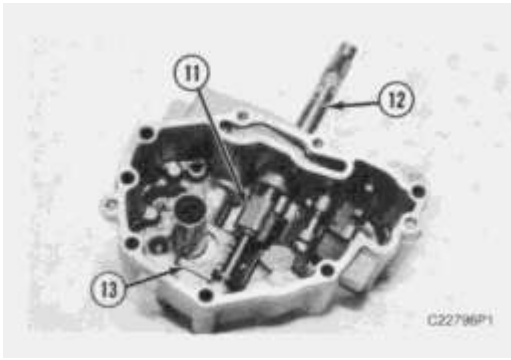

5. Remove shaft assembly (12) and levers (11) and (13).

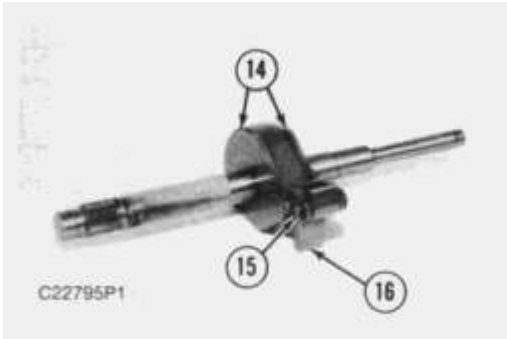

6. Remove the two snap rings from pins (15) and remove pins (15). Remove plates (14) and stop (16).

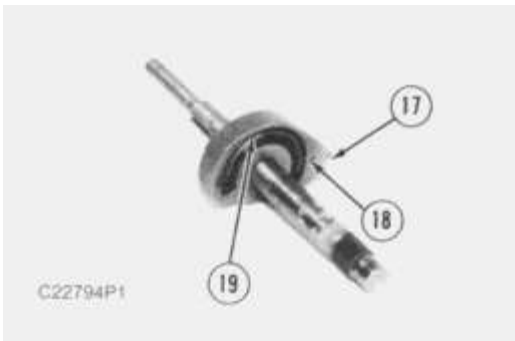

7. Remove pins (18) and (17) and spring (19).

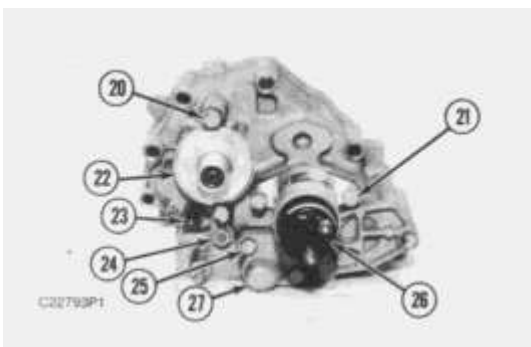

8. Remove two bolts (20) adapter (22), the coupling, and the O-ring seal.

9. Remove contact (23) and body (24).

10. Remove two bolts (25), cover (27), and the gasket.

11. Remove two bolts (21), shutoff solenoid (26), and the gasket.

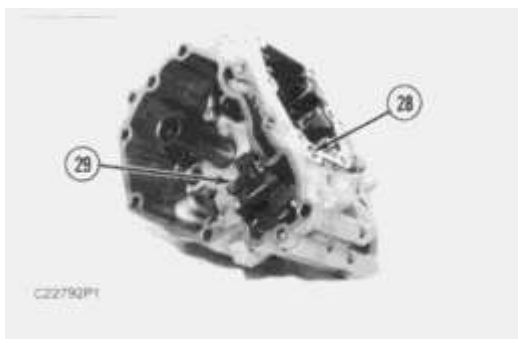

12. Remove shaft (28) and lever (29).

---

### NOTICE

**The check valve will be damaged during removal. Remove check valve (30) only if a replacement is necessary.**

---

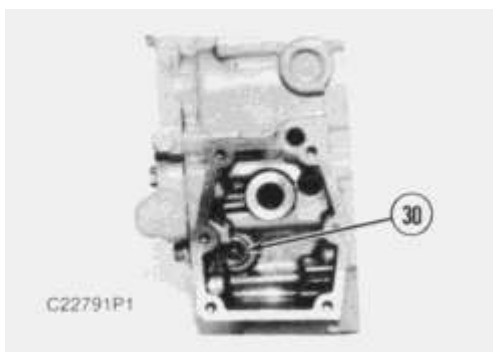

13. Remove check valve (30) if a replacement is necessary.

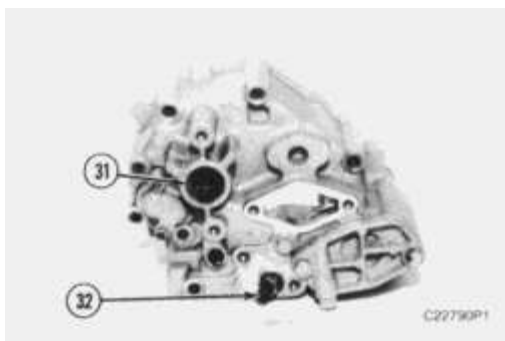

Remove seal (31) and adjustment screw (32).

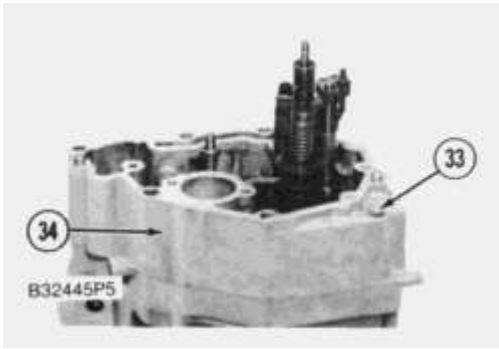

15. Remove bolt (33), housing (34), and the gasket from the fuel injection pump housing.

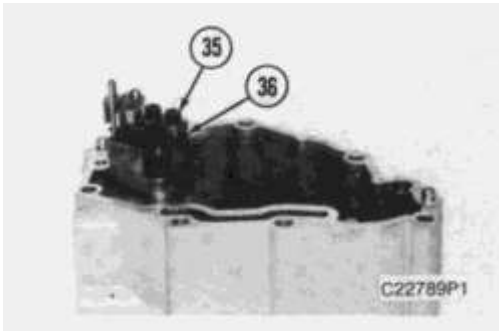

16. Remove bolts (35) and torque control group (36).

17. Disassemble the torque control group and inspect the spacer, the spring and the insulator for damage or wear.

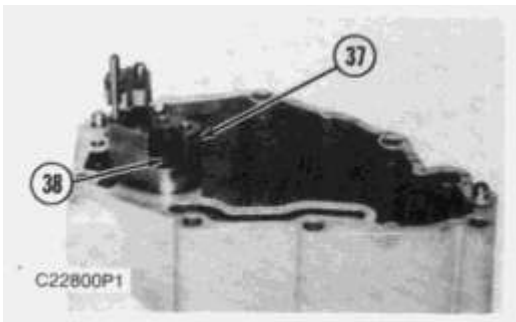

18. Remove two bolts (38) and block (37).

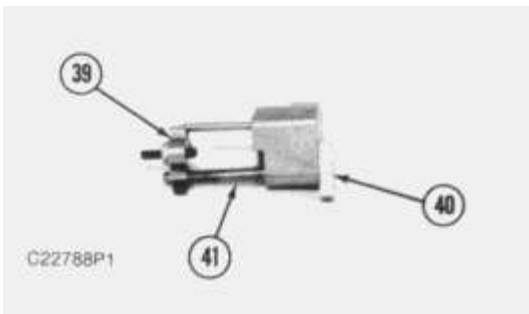

19. Remove the bolt that holds collar (39) to bolt (40). Remove collar (39), spring (41) and bolt (40).

20. Remove the stop screw from collar (39) if a replacement is necessary.

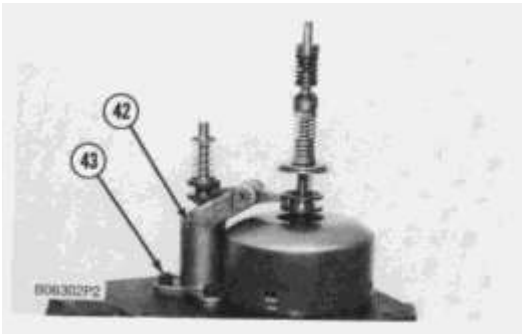

21. Remove bolts (42) and governor servo (43).

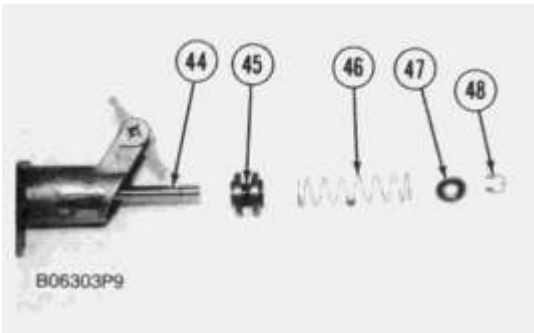

22. Remove locking (48), seat (47), spring (broken link spring) (46) and sleeve (45). Remove the other locking (48) from the groove in the center of valve (44).

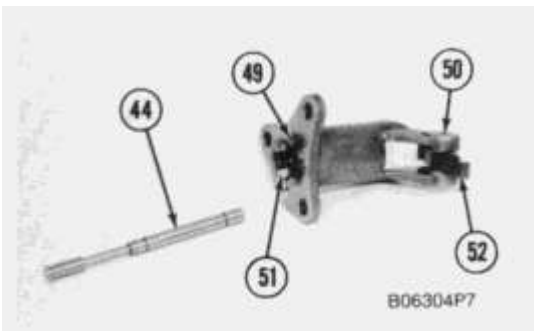

23. Remove valve (44), sleeve (49) and piston (51). Remove the O-ring seal from sleeve (49).

24. Remove pin (50) and lever (52).

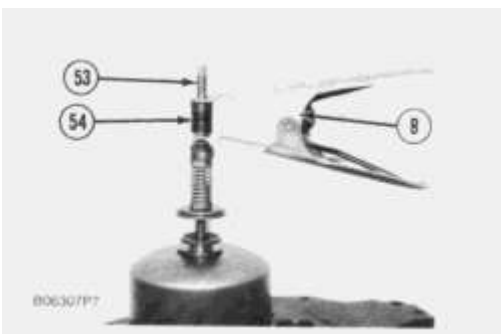

25. Use tooling (B) to hold spring (54) in compression for removal of ring (53). Spring (54) is used to put a preload on the thrust bearing for the camshaft in the fuel injection pump housing.

26. Remove ring (53) and tool (B).

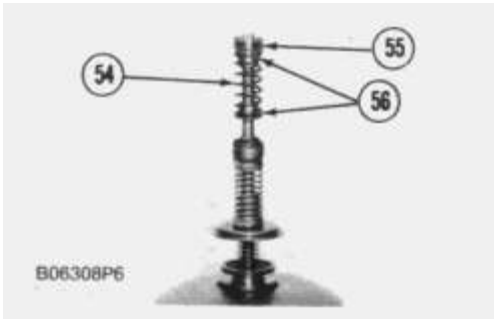

27. Remove bearing (55), sleeves (56) and spring (54).

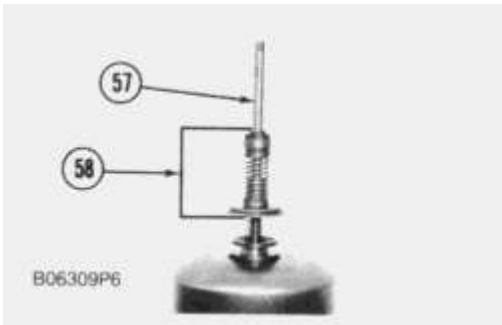

28. Remove ring (57) and dashpot assembly (58).

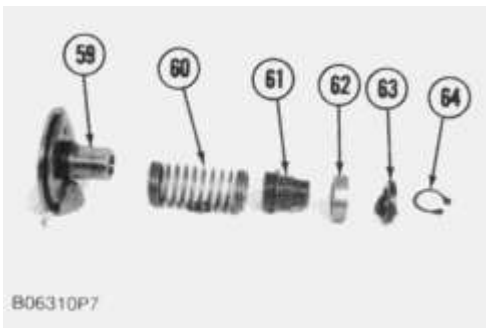

29. Use tool (C) to remove snap ring (64). Remove ring (63) and spool (62).

30. Remove seat (61) from spring (60) and remove spring (60) from seat (59).

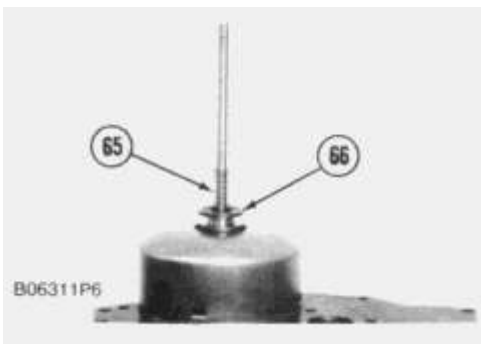

31. Remove spring (overfueling spring) (65) and riser (66).

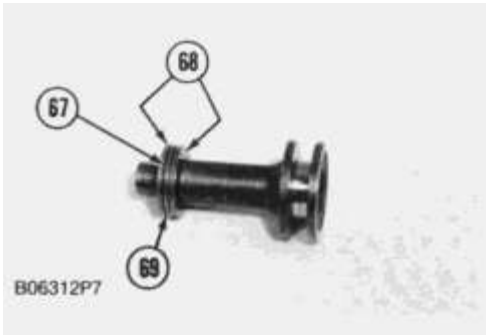

32. Remove ring (67), races (68) and bearing (69).

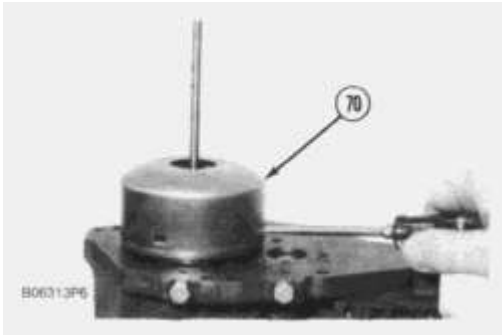

**NOTE:** Make a replacement of shield (70) any time it is removed.

33. Use a screwdriver to remove shield (70) as shown.

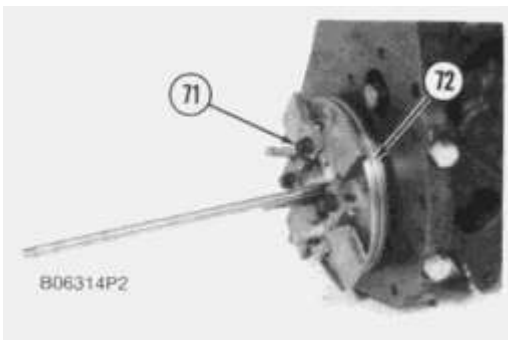

34. Remove bolts (71) and carrier (72).

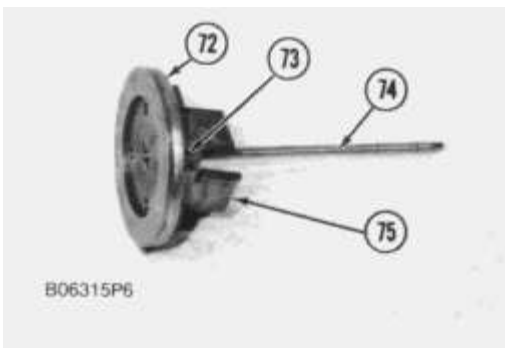

35. Remove dowels (73) and flyweights (75).

36. Remove shaft (74) and the dowel from shaft (74).

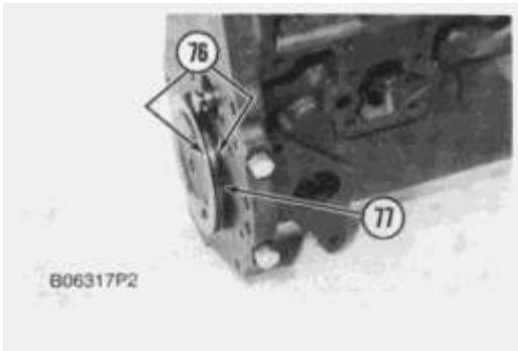

37. Remove races (76) and bearing (77).

## Assemble Governor

Tools Needed		A	B	C	D
1P510	Driver Group	1			
6V2163	Clamp Assembly-Spring Compressor		1		
1P1855	Snap Ring Pliers			1	
6V2054	Shield Driver				1

**NOTE:** Put clean oil on all parts before assembly. Be sure all oil passages are clear.

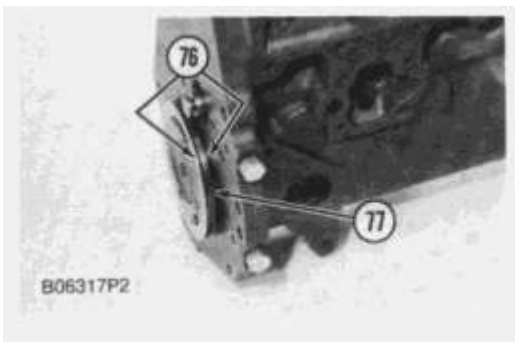

1. Install one race (76), bearing (77) and the other race on the camshaft in the fuel injection pump housing.

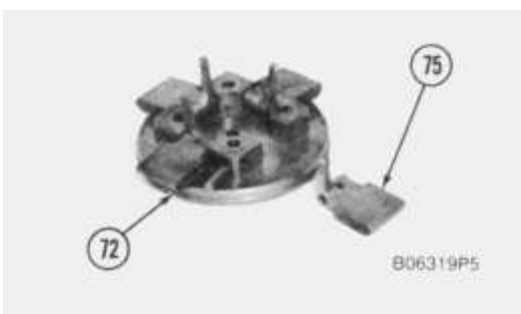

2. Put flyweights (75) in position on carrier (72) and install the dowels to hold the flyweights in place. The flyweights must move freely on the dowels and have **0.010 to 0.23 mm (0.0004 to 0.009 in)** end play.

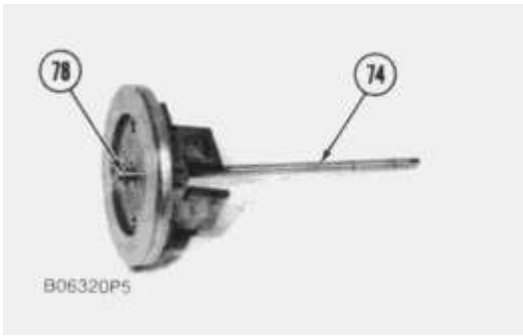

3. Install dowel (78) in governor shaft (74) and install the governor shaft in the carrier as shown.

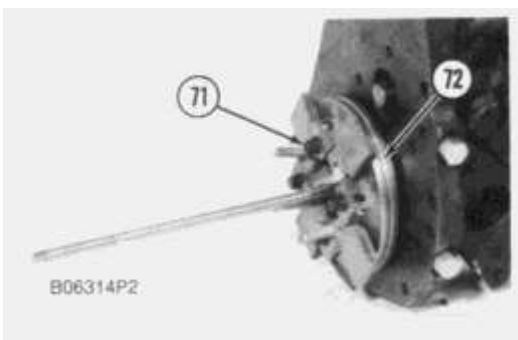

4. Put carrier (72) in position and install bolts (71).

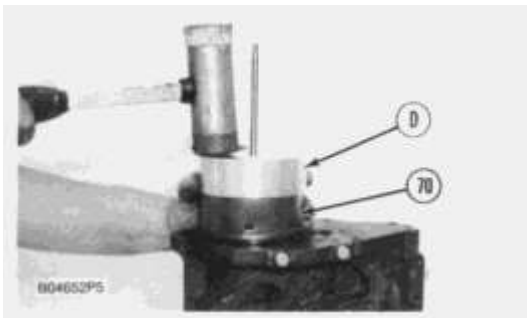

**NOTE:** Replace shield (70) any time that it is removed.

5. Install shield (70) on the carrier and use tooling (D) to push the shield against its seat. Use a hammer and punch to move the metal (stake) to places on the side of the shield  $180^\circ \pm 15^\circ$  apart next to the holes on the shield.

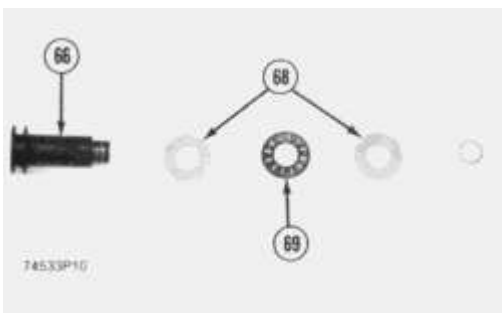

6. Install race (68), bearing (69), and second race (68). Use tooling (C) to install the ring on riser (66) as shown.

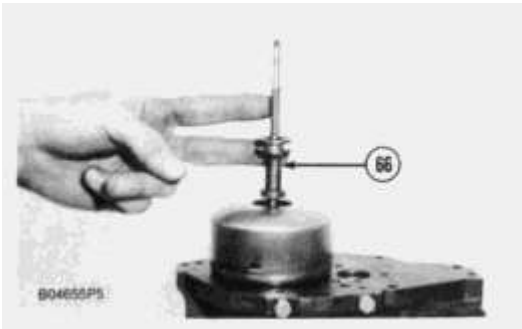

7. Install riser (66) and spring (overfueling spring) as shown.

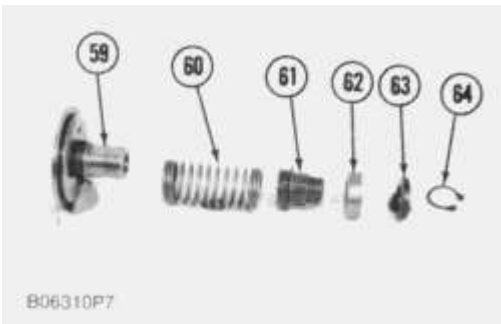

8. Assemble the dashpot as follows:

- a. Install spring (60) on seat (59) and install seat (61) in spring (60).
- b. Put spool and ring (63) in position on seat (61) and tool (C) to install snap ring (64).

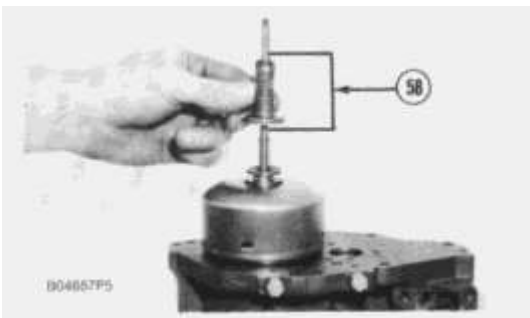

9. Install dashpot assembly (58) as shown.

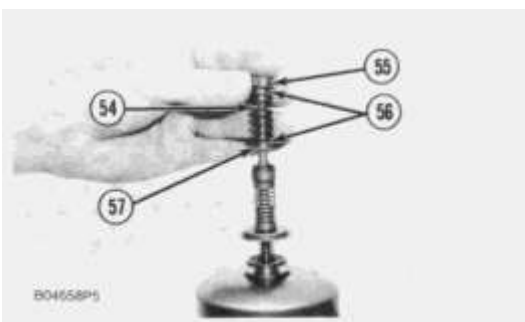

**10.** Install ring (57) in the lower groove in the governor shaft. Install sleeve (56), spring (54), second sleeve (56) and bearing (55).

**NOTE:** Spring (54) is used to put a preload on the thrust bearing on the camshaft in the fuel injection pump housing.

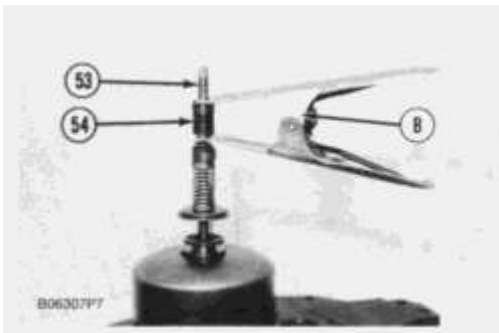

**11.** Use tooling (B) to hold spring (54) in compression and install ring (53) in the groove in the governor shaft. Remove tooling (B).

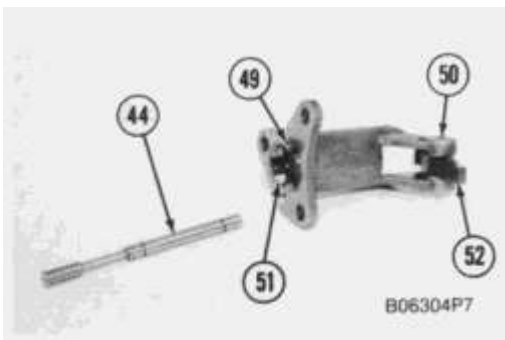

**12.** Put lever (52) in position on the governor servo and install pin (50) to hold the lever in place. Use a hammer and chisel to move the metal (stake) four places **90°** apart on the outside surface on both legs of the governor servo to hold pin (50) in place.

**13.** Install the O-ring seal on sleeve (49). Install piston (51) and sleeve (49) as shown.

**14.** Install valve (44) as shown.

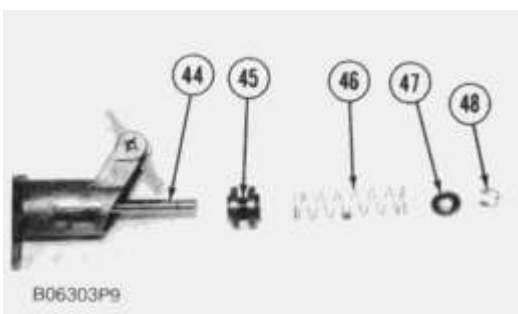

**15.** Install one lockring (48) in the groove near the center of valve (44). Put sleeve (45), spring (broken link spring) (46) and seat (47) in position on valve (44) and install the second lockring (48).

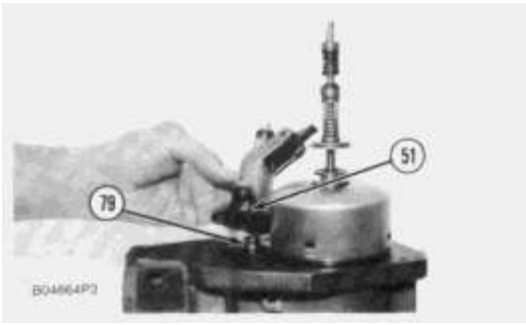

**16.** Put the governor servo in position on the fuel injection pump housing with piston (51) engaged over rack (79) and install the bolts.

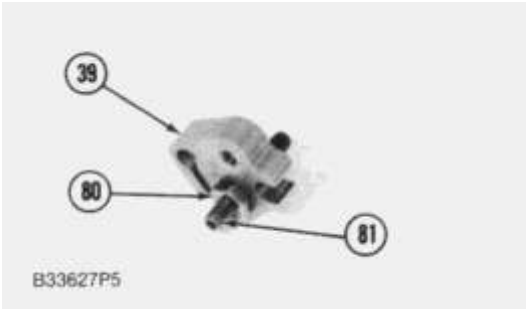

**17.** Install torque rise adjustment screw (81) in collar (39) as shown and install locknut (80).

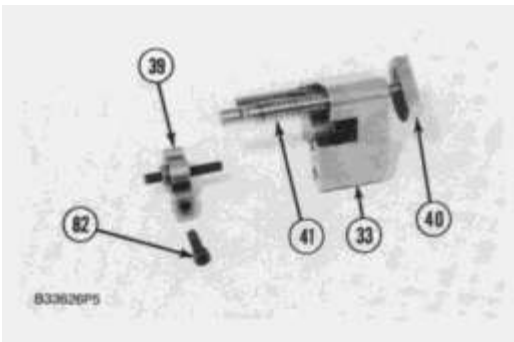

**18.** Install bolt (40) in block (37) as shown. Install spring (41) on bolt (40) as shown. Put collar in alignment with the notch in bolt (40) and install bolt (82) to hold the collar in place.

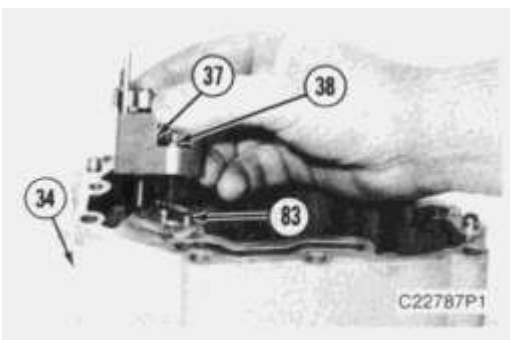

**19.** Put block (37) in position on housing (34) with the holes in block (37) in alignment with dowels (83). tighten two bolts (38).

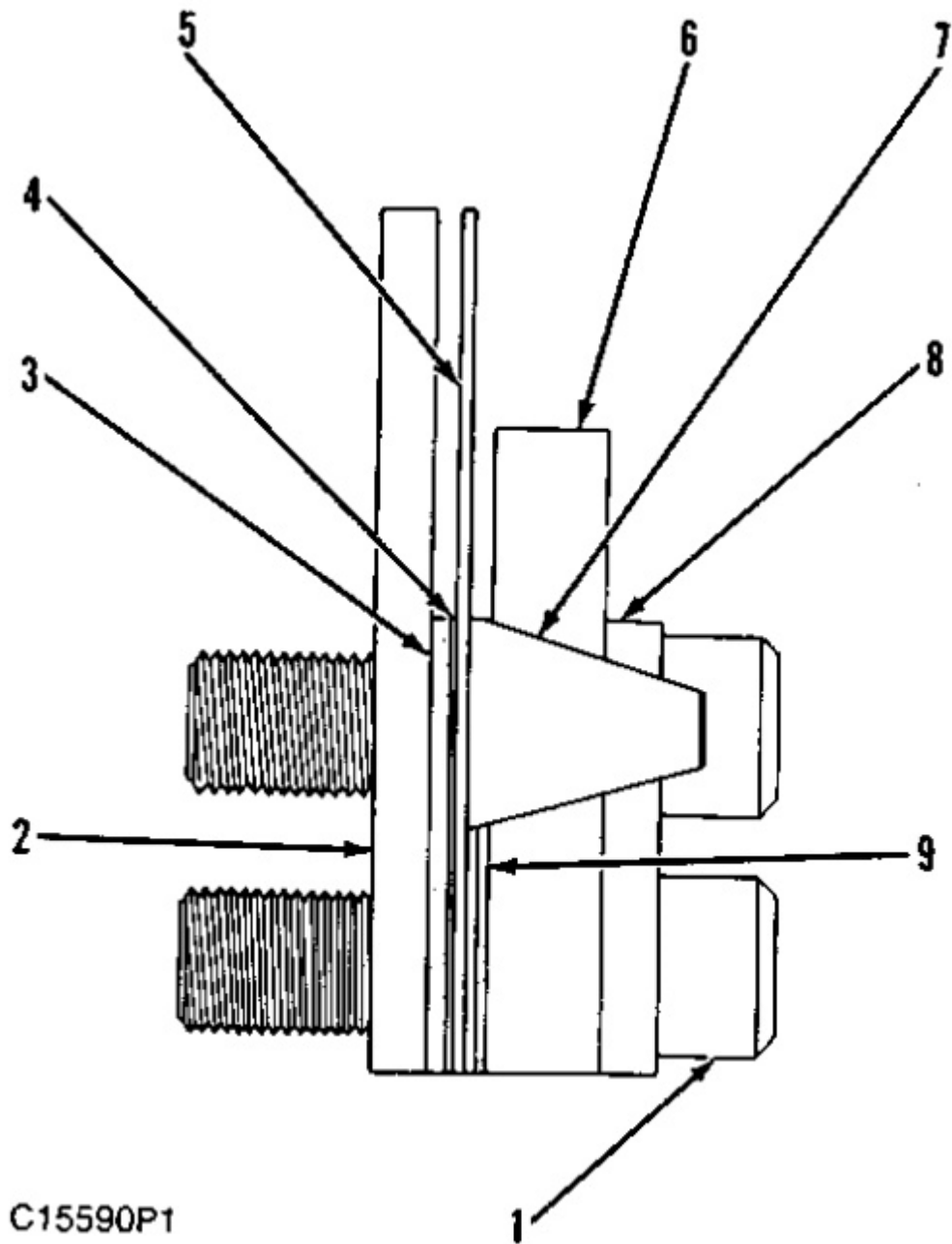

C15590P1

20. Assemble the torque control group as follows:

- a. Install spring (5), shim (4), contact (7), and spacer (9) on insulator (3) as shown.
- b. Install retainer (8), bar (6), the insulator assembly rod bar (2) on bolts (1).

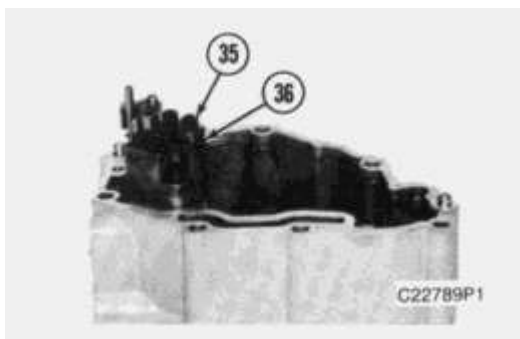

21. Put torque control group (36) in position on block (37). Install bolts (35).

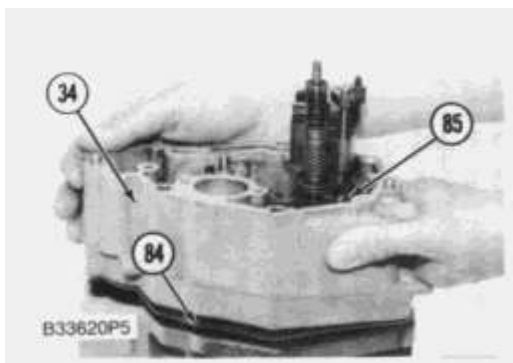

**! WARNING**

**When housing (34) is installed on the fuel injection pump housing, the flange on bolt (85) must be behind the dashpot. If housing (34) is installed with the flange on bolt (85) on the wrong side of the dashpot, the riser in the governor will be held in the maximum fuel delivery position.**

22. Install gasket (84) on the fuel injection pump housing. Put housing (34) in position on the fuel injection pump housing with bolt (85) behind the dashpot as shown. Install the bolts that hold housing (34) in place.

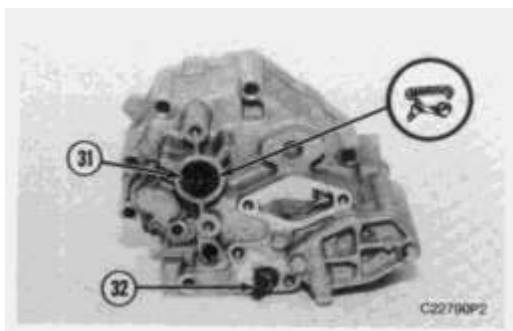

23. Use tooling (A) to install lip type seal (31) in the outer governor housing with the lip in, as shown.

24. Install adjustment screw (32) and the locknut for the high idle adjustment.

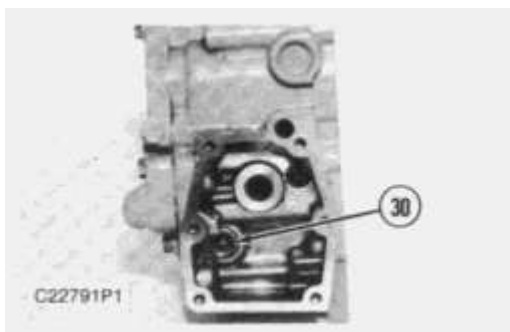



**Suggest:**

**For more complete manuals. Please go to the home page.**

**<https://www.ebooklibonline.com>**

**If the above button click is invalid. Please download this document first, and then click the above link to download the complete manual.**

**Thank you so much for reading**

25. Install check valve (30).

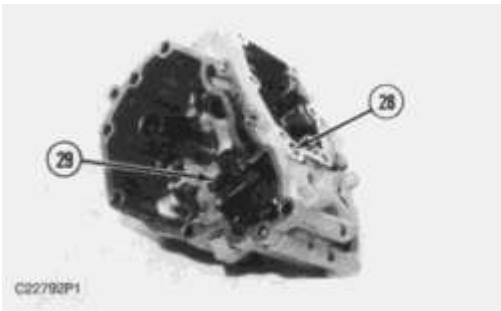

26. Put lever (29) in position as shown. Install shaft (28).

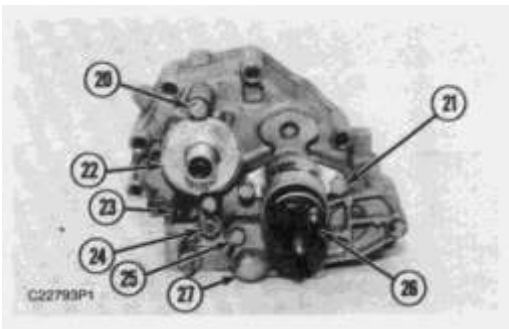

27. Put gasket and shutoff solenoid (26) in position and install two bolts (21).

28. Put the gasket and cover (27) in position and install two bolts (25).

29. Install body (24) and contact (23).

30. Put the O-ring seal on adapter (22) and put the coupling and adapter (22) in position. Install two bolts (20).

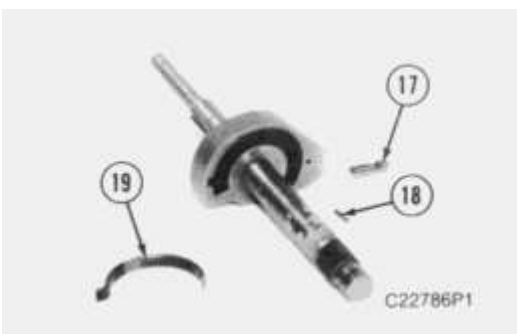

31. Install spring (19) in shaft assembly (12). Install pin (17) engaged in the hole in spring (19). Install pin (18) in shaft assembly (12) to hold pin (17) in place.

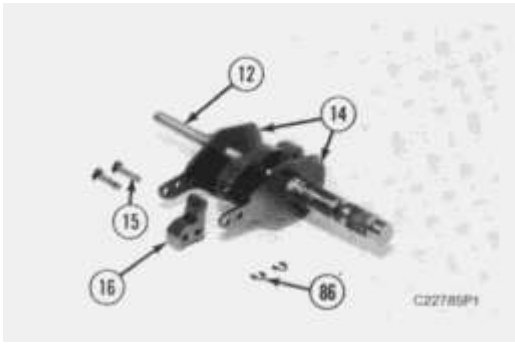

**32.** Put stop (16) and plates (14) in position on shaft assembly (12) and install snap rings (86).

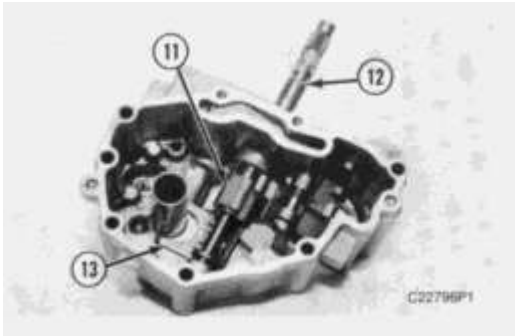

**33.** Put levers (11) and (13) in position in the housing as shown and install shaft assembly (12).

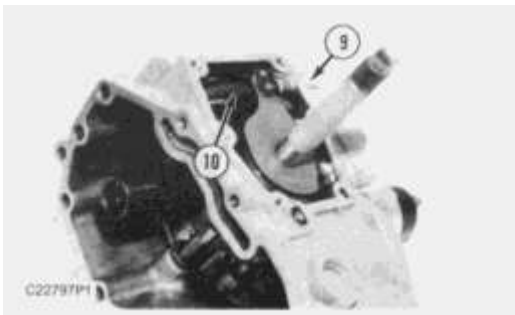

**34.** Install adjustment screw (9) and the locknut for the slow idle adjustment. Install spring (10) in the hole in the shaft assembly and in the housing.

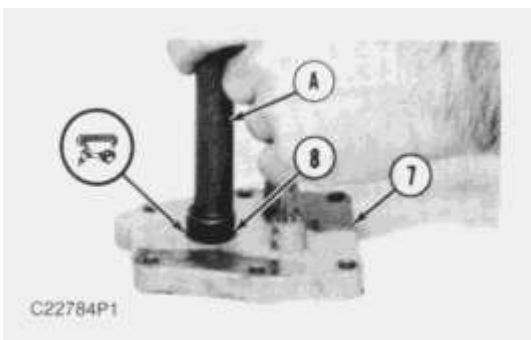

**35.** Use tooling (A) to install the lip type seal (8) in cover (7) with lip as shown.

**<https://www.ebooklibonline.com>**

Hello dear friend!

Thank you very much for reading.

Enter the link into your browser.

The full manual is available for immediate download.

**<https://www.ebooklibonline.com>**