

Product: WHEEL DOZER

Model: 824G II WHEEL DOZER AWW

Configuration: 824G II Wheel Tractor AWW00001-UP (MACHINE) POWERED BY 3406 Engine

Disassembly and Assembly

826G Series II Landfill Compactor, 825G Series II Soil Compactor and 824G Series II Wheel Dozer Power Train

Media Number -REN6029-03

Publication Date -01/06/2006

Date Updated -21/06/2006

i04400923

Torque Converter - Disassemble - Heavy Duty

SMCS - 3101-015

Disassembly Procedure

Table 1

Required Tools			
Tool	Part Number	Part Description	Qty
A	138-7573	Link Bracket	1
B	8B-7548	Push-Puller	1
	8B-7550	Leg	2
	8H-0684	Ratchet Wrench	1
	8B-7560	Step Plate	1
	8H-0663	Bearing Puller Attachment	1
C	8B-7548	Push-Puller	1
	8H-0684	Ratchet Wrench	1
	8B-7549	Leg	2
	5P-4808	Cap	2
	8B-7554	Bearing Cup Puller Attachment	1
D	5F-7343	Bearing Puller Attachment	1
	1P-0520	Driver Group	1
E	1P-0520	Driver Group	1

Start By:

- a. Separate the torque converter from the transmission and from the output transfer gears. Refer to Disassembly and Assembly, "Torque Converter from Transmission, Output Transfer Gears - Separate" for the machine that is being serviced.
1. Place the torque converter housing assembly on wood blocks.

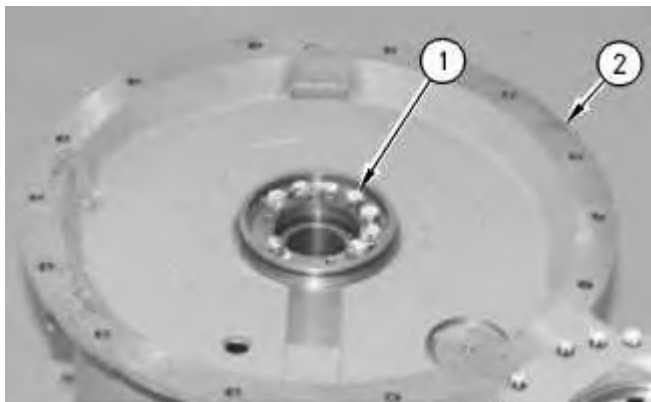

Illustration 1

g00503225

2. Remove eight bolts (1) and the washers from torque converter housing assembly (2).

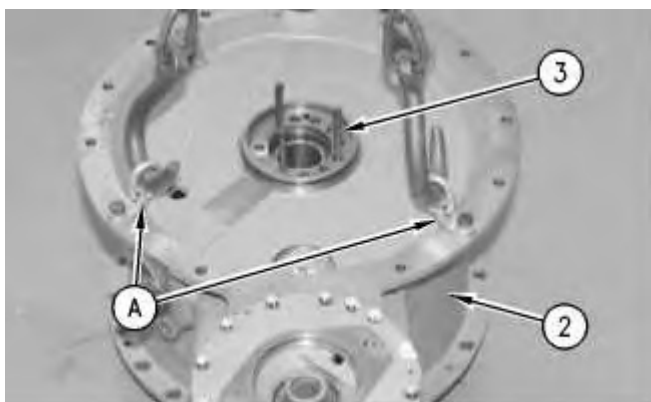

Illustration 2

g00503286

3. Install Tooling (A) to torque converter housing assembly (2), as shown. Attach a hoist and suitable lifting chains to Tooling (A).
 4. Use three 3/8" - 16 NC forcing screws (3) to loosen housing assembly (2) from the torque converter.
 5. Use the hoist to remove housing assembly (2) from the torque converter. The weight of housing assembly (2) is 120 kg (265 lb).
-

<https://www.ebooklibonline.com>

Hello dear friend!

Thank you very much for reading.

Enter the link into your browser.

The full manual is available for immediate download.

<https://www.ebooklibonline.com>

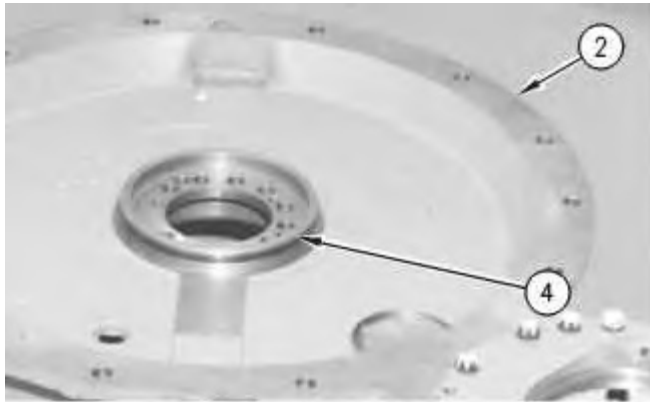

Illustration 3

g00503287

6. Remove O-ring seal (4) from torque converter housing assembly (2).

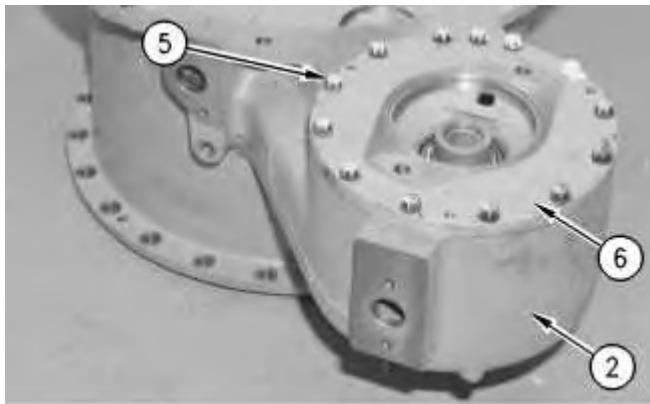

Illustration 4

g00503288

7. Remove thirteen bolts (5) and the washers from pump adapter (6) and torque converter housing assembly (2).

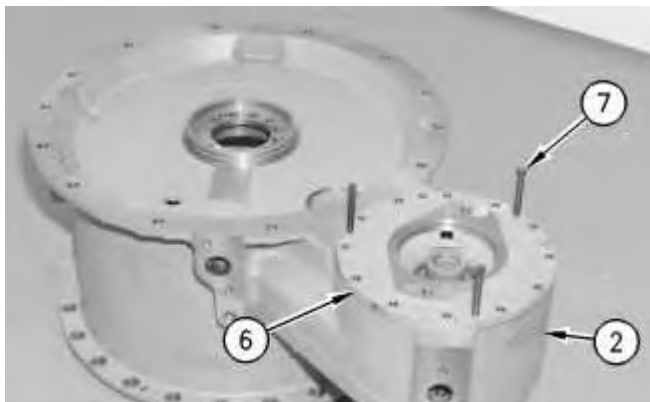

Illustration 5

g00503289

8. Use three 3/8" - 16 NC forcing screws (7) to remove pump adapter (6) from torque converter housing assembly (2).



Illustration 6

g00503291

9. Remove bearing cup (8), O-ring seal (10) and shims (9) from pump adapter (6).



Illustration 7

g00503292

10. Remove pump drive gear (11) from torque converter housing assembly (2).

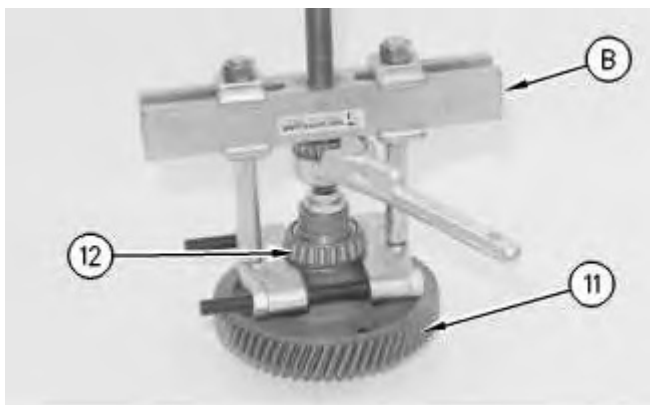

Illustration 8

g00503294

11. Use Tooling (B) to remove bearing cones (12) from each side to pump drive gear (11).



Illustration 9

g00503296

12. Use Tooling (C) to remove bearing cup (13) from torque converter housing assembly (2).

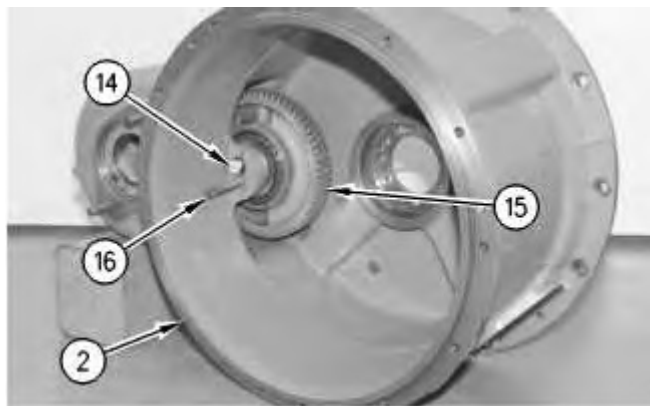

Illustration 10

g00503297

13. Remove bolt (14) and the washer from torque converter housing assembly (2).
14. Use 3/8" - 16 NC forcing screw (16) to push the shaft assembly out of torque converter housing assembly (2).
15. Remove idler gear (15) from torque converter housing assembly (2).

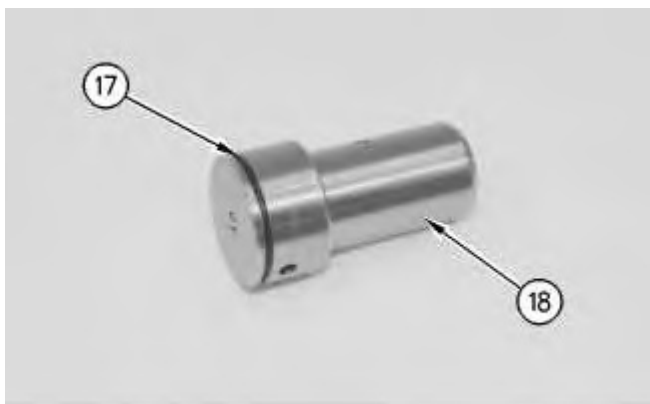

Illustration 11

g00503298

16. Remove O-ring seal (17) from shaft assembly (18).

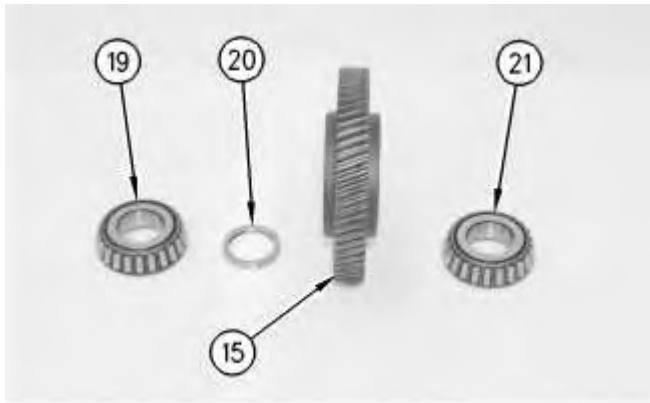

Illustration 12

g00503299

17. Remove bearing cone (19), bearing cone spacer (20) and bearing cone (21) from idler gear (15).

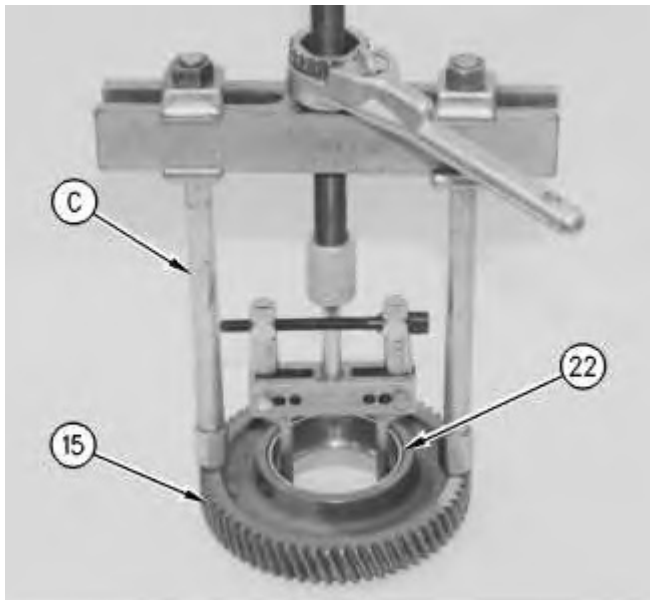

Illustration 13

g00503301

18. Use Tooling (C) to remove bearing cup (22) from idler gear (15).



Illustration 14

g00503302

19. Remove bearing cup spacer (23) from idler gear (15).

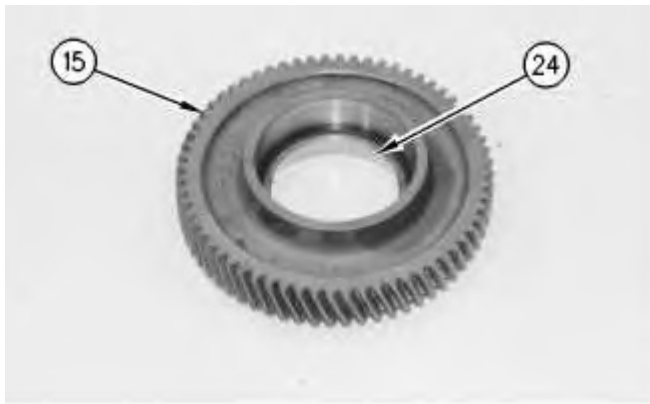

Illustration 15

g00503308

20. Remove retaining ring (24) from idler gear (15).

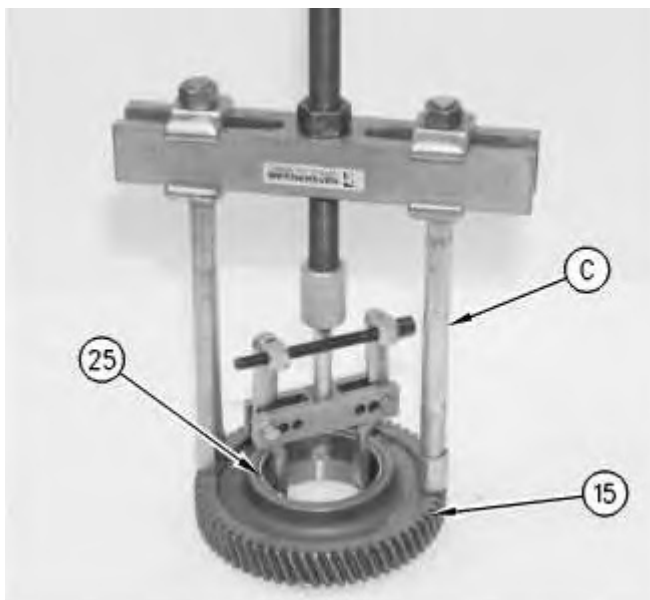

Illustration 16

g00503309

21. Use Tooling (C) to remove bearing cup (25) from idler gear (15).

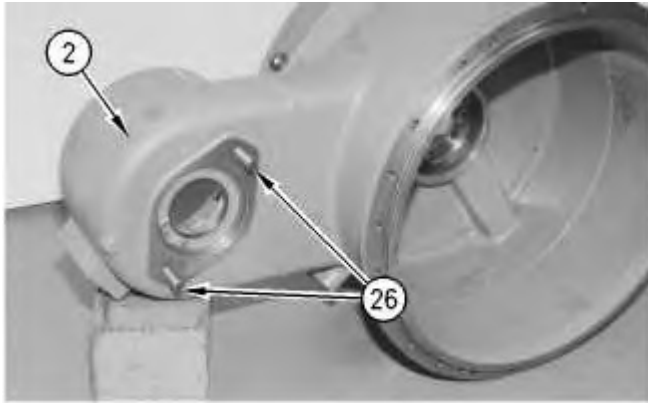

Illustration 17

g00503312

22. Remove two studs (26) from torque converter housing assembly (2).



Illustration 18

g00503314

23. Remove retaining ring (27) and bearing carrier (28) from the carrier assembly.

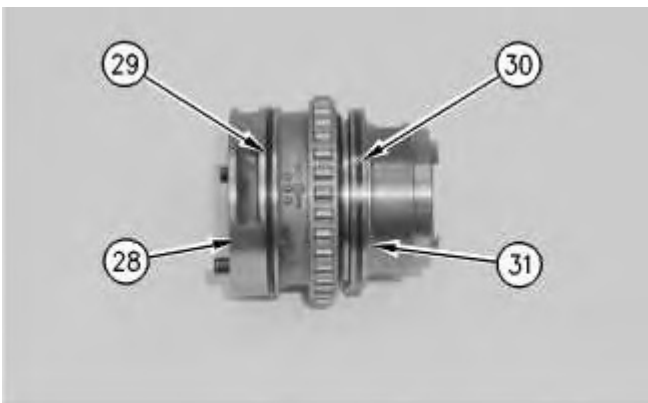

Illustration 19

g00503315

24. Remove O-ring seal (29) from bearing carrier (28).

25. Remove seal ring (30) from ring carrier (31).

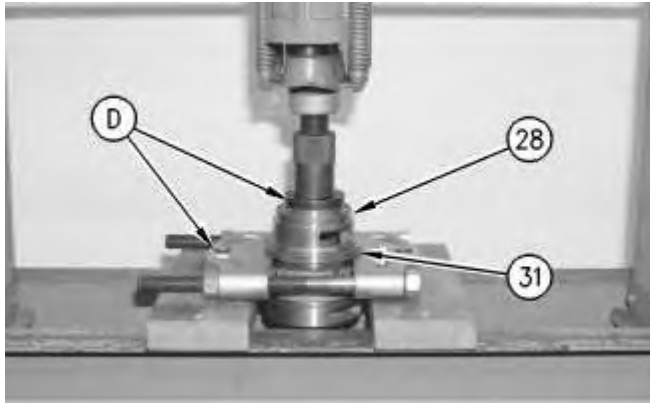

Illustration 20

g00503316

26. Use Tooling (D) and a press to remove ring carrier (31) from bearing carrier (28).



Illustration 21

g00503318

27. Remove retaining ring (32) from bearing carrier (28).

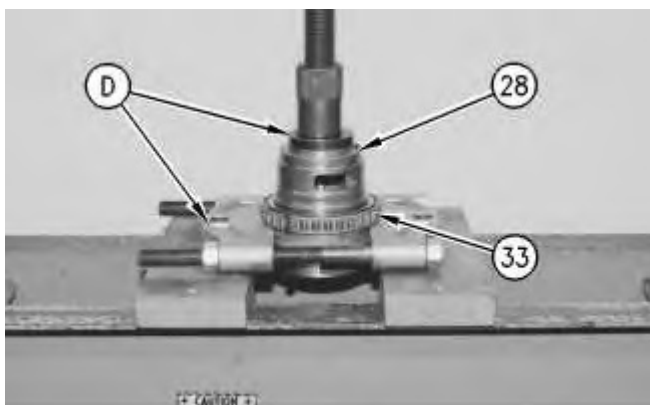

Illustration 22

g00503319

28. Use Tooling (D) and a press to remove inner bearing (33) from bearing carrier (28).



Illustration 23

g00503321

29. Remove twelve bolts (34) and the washers from drive gear (35).
30. Remove drive gear (35) from the drive flange.

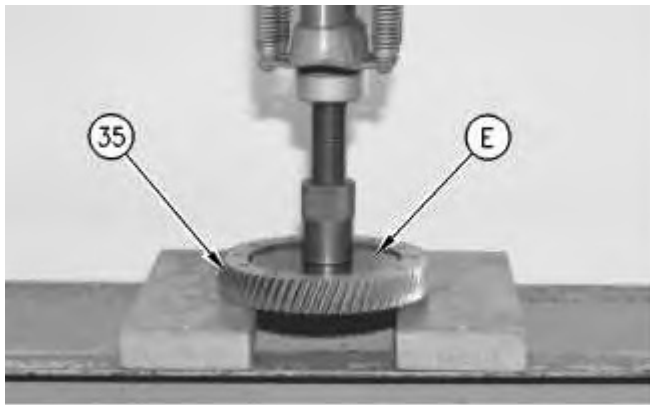

Illustration 24

g00503322

31. Use Tooling (E) and a press to remove the outer bearing race from drive gear (35).

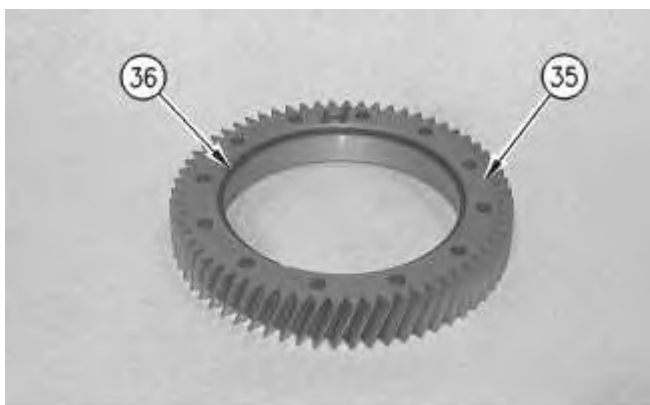

Illustration 25

g00503344

32. Remove retaining ring (36) from drive gear (35).



Illustration 26

g00503345

33. Remove 36 bolts (37) from drive flange (38) and rotating housing (39).

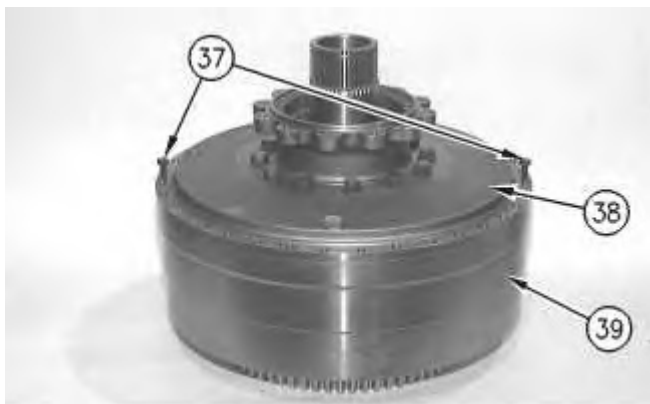

Illustration 27

g00503347

34. Use two bolts (37) as forcing screws to remove drive flange (38) from rotating housing (39). The weight of drive flange (38) is 23 kg (51 lb).



Illustration 28

g00503348

35. Place the impeller hub on wood blocks.
36. Remove twelve bolts (40) from drive flange (38).

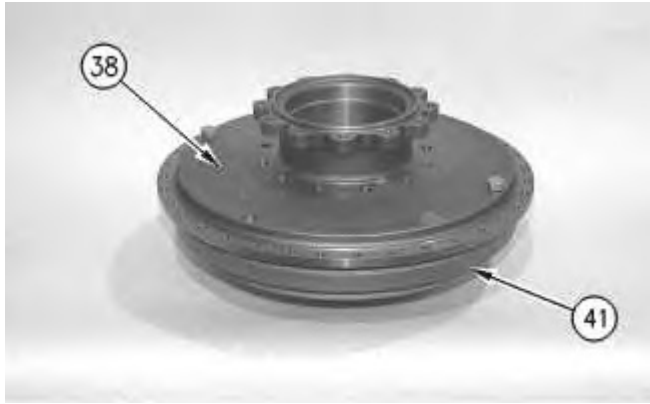

Illustration 29

g00503350

37. Remove drive flange (38) from the impeller hub and converter impeller (41).

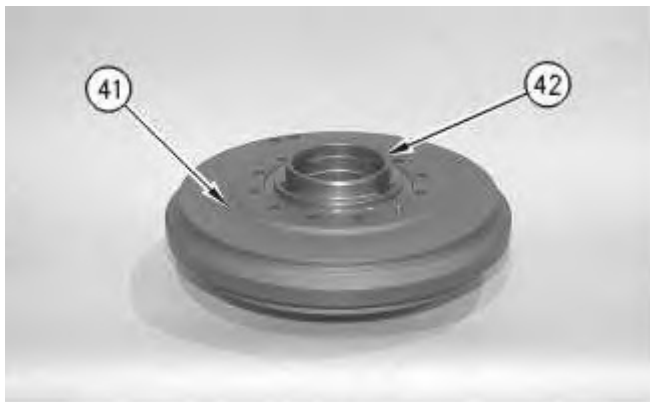

Illustration 30

g00503351

38. Remove converter impeller (41) from impeller hub (42).



Illustration 31

g00503352

39. Remove two thrust bearing races (43) and the thrust bearing from the carrier assembly.



Illustration 32

g00503533

40. Remove carrier assembly (44) and the stator as a unit from rotating housing (39).



Illustration 33

g00503534

41. Remove snap ring (45).



Illustration 34

g00503535

42. Heat stator (46) and carrier assembly (44) as a unit to a minimum temperature of 121°C (250°F) for one hour. This will expand stator (46).
43. Remove stator (46) from carrier assembly (44).



Illustration 35

g00503536

44. Remove retainer ring (47) from stator (46).



Illustration 36

g00503537

45. Remove sleeve bearing (48) from carrier assembly (44).

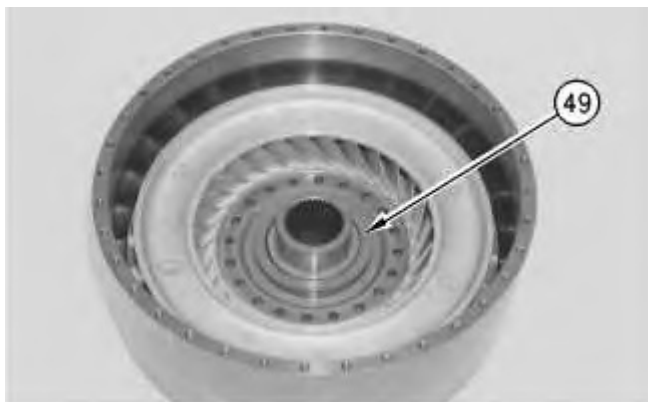

Illustration 37

g00503538

46. Remove two thrust bearing races (49) and the thrust bearing from the hub.

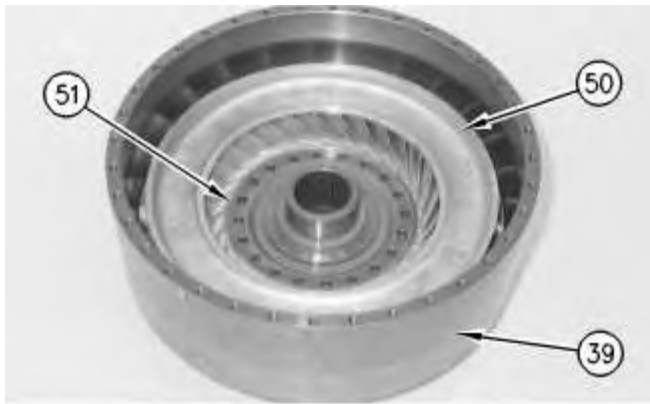

Illustration 38

g00503539

47. Remove converter turbine (50) and turbine hub (51) as a unit from rotating housing (39).

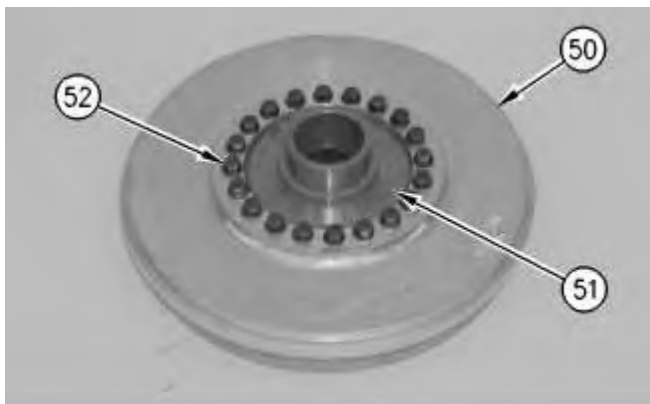

Illustration 39

g00503540

48. Remove twenty bolts (52) and the washers from converter turbine (50).
49. Remove converter turbine (50) from turbine hub (51).

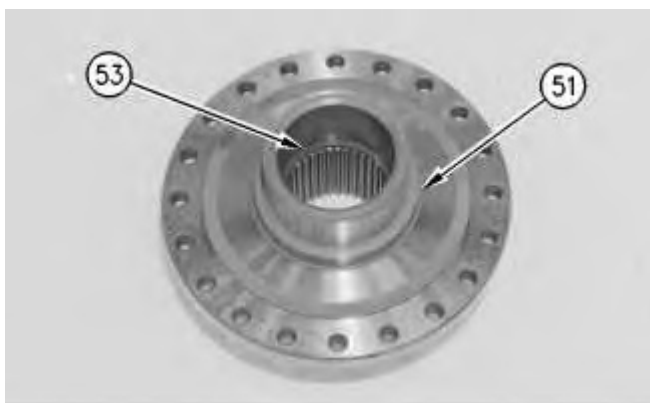

Illustration 40

g00503541

50. Remove retaining ring (53) from turbine hub (51).



Illustration 41

g00503542

51. Remove two thrust bearing races (54) and thrust bearing (55) from the cover assembly.

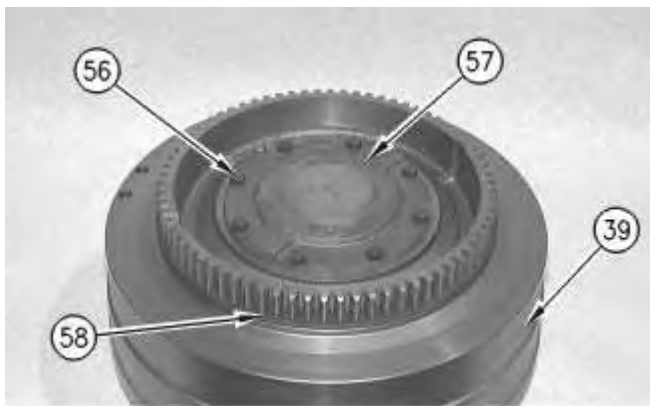

Illustration 42

g00503564

52. Remove eight bolts (56) and the washers from cover assembly (57).
53. Remove cover assembly (57) from rotating housing (39).
54. Remove ring seal (58) from rotating housing (39).



Illustration 43

g00503567

55. Remove sleeve bearing (59) from cover assembly (57).

Product: WHEEL DOZER

Model: 824G II WHEEL DOZER AWW

Configuration: 824G II Wheel Tractor AWW00001-UP (MACHINE) POWERED BY 3406 Engine

Disassembly and Assembly

826G Series II Landfill Compactor, 825G Series II Soil Compactor and 824G Series II Wheel Dozer Power Train

Media Number -REN6029-03

Publication Date -01/06/2006

Date Updated -21/06/2006

i04400940

Torque Converter - Assemble - Heavy duty

SMCS - 3101-016

Assembly Procedure

Table 1

Required Tools			
Tool	Part Number	Part Description	Qty
A	138-7573	Link Bracket	3
B	8T-5096	Dial Indicator Test Group	1
	5P-2390	Gauge Tool Group	1
C	1P-0520	Driver Group	1

Note: Cleanliness is an important factor. Before assembly, all parts should be thoroughly cleaned in cleaning fluid. Allow the parts to air dry. Wiping cloths or rags should not be used to dry parts. Lint may be deposited on the parts which may cause later trouble. Inspect all parts. If any parts are worn or damaged, use new parts for replacement.

Note: Apply oil to all of the bearings before assembly.



Suggest:

For more complete manuals. Please go to the home page.

<https://www.ebooklibonline.com>

If the above button click is invalid. Please download this document first, and then click the above link to download the complete manual.

Thank you so much for reading

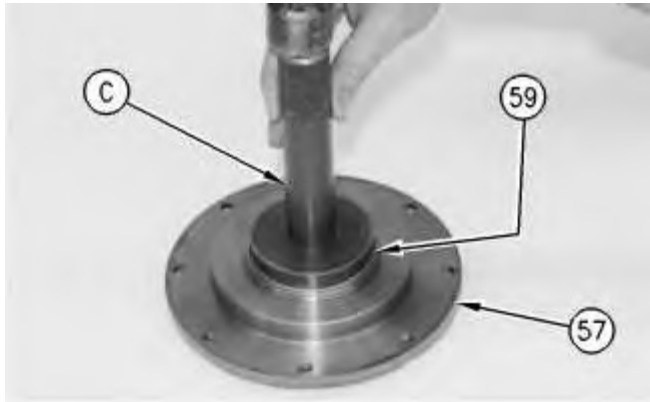

Illustration 1

g00504278

1. Use Tooling (C) to install sleeve bearing (59) in cover assembly (57). Sleeve bearing (59) must be even with the outside surface of cover assembly (57).



Illustration 2

g00504279

2. Install cover assembly (57) to rotating housing (39).

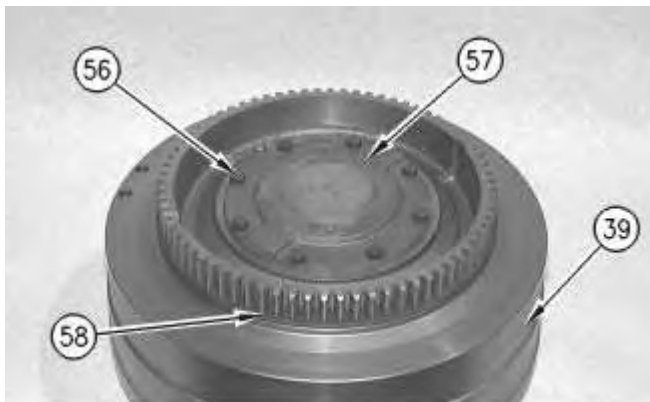

Illustration 3

g00503564

3. Install ring seal (58) to rotating housing (39).

4. Install eight bolts (56) and the washers. Tighten the bolts to a torque of 30 ± 5 N·m (22 ± 4 lb ft).

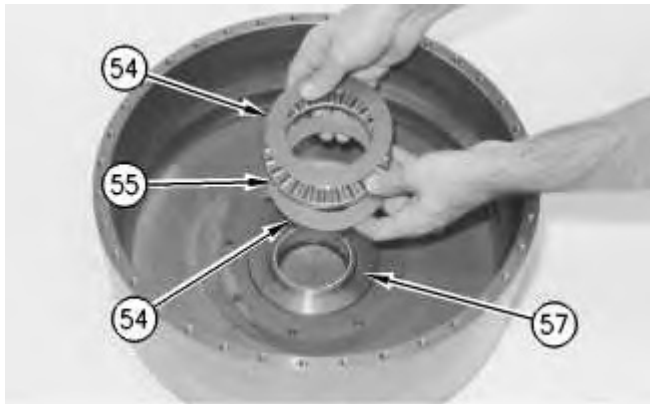

Illustration 4

g00504307

5. Install thrust bearing race (54), thrust bearing (55), and thrust bearing race (54) to cover assembly (57).



Illustration 5

g00504312

6. Install retaining ring (53) in turbine hub (51).

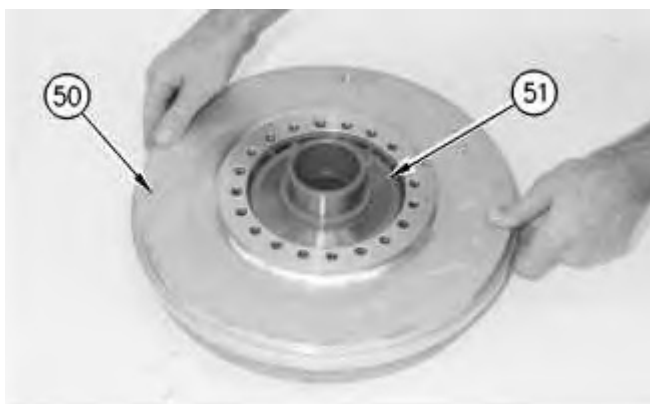

Illustration 6

g00504313

<https://www.ebooklibonline.com>

Hello dear friend!

Thank you very much for reading.

Enter the link into your browser.

The full manual is available for immediate download.

<https://www.ebooklibonline.com>