

Product: WHEEL DOZER

Model: 824C WHEEL DOZER 85X

Configuration: 824C TRACTOR 85X01194-UP (MACHINE) POWERED BY 3406 ENGINE

## **Disassembly and Assembly 3406E and 3456 Engines for Caterpillar Built Machines**

Media Number -REN1364-06

Publication Date -01/05/2008

Date Updated -20/05/2008

i02489840

# **Cylinder Head - Remove**

SMCS - 1100-011

## **Removal Procedure**

### **Start By:**

- A. Remove the water temperature regulator. Refer to Disassembly and Assembly, "Water Temperature Regulator - Remove and Install".
- B. Remove the exhaust manifold. Refer to Disassembly and Assembly, "Exhaust Manifold - Remove and Install".
- C. Remove the valve mechanism cover base. Refer to Disassembly and Assembly, "Valve Mechanism Cover Base - Remove and Install".
- D. Remove the electronic unit injectors. Refer to Disassembly and Assembly, "Electronic Unit Injector - Remove".
- E. Remove the camshaft gear. Refer to Disassembly and Assembly, "Camshaft Gear - Remove and Install".

---

### **NOTICE**

**Keep all parts clean from contaminants.**

**Contaminants may cause rapid wear and shortened component life.**

---

---

### **NOTICE**

**Care must be taken to ensure that fluids are contained during performance of inspection, maintenance, testing, adjusting and repair of the product. Be prepared to collect the fluid with suitable containers**

**before opening any compartment or disassembling any component containing fluids.**

**Refer to Special Publication, NENG2500, "Caterpillar Dealer Service Tool Catalog" for tools and supplies suitable to collect and contain fluids on Caterpillar products.**

**Dispose of all fluids according to local regulations and mandates.**

---

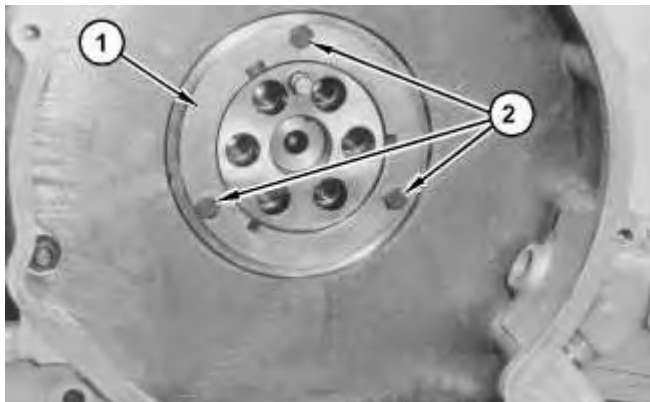

Illustration 1

g01028806

---

### **NOTICE**

**Do not turn the crankshaft or the camshaft while the camshaft gear is removed. If the front gear group is not correctly timed during installation, interference can occur between the pistons and the valves, resulting in damage to the engine.**

---

1. Remove bolts (2) and thrust plate (1) .
-

**<https://www.ebooklibonline.com>**

Hello dear friend!

Thank you very much for reading.

Enter the link into your browser.

The full manual is available for immediate download.

**<https://www.ebooklibonline.com>**

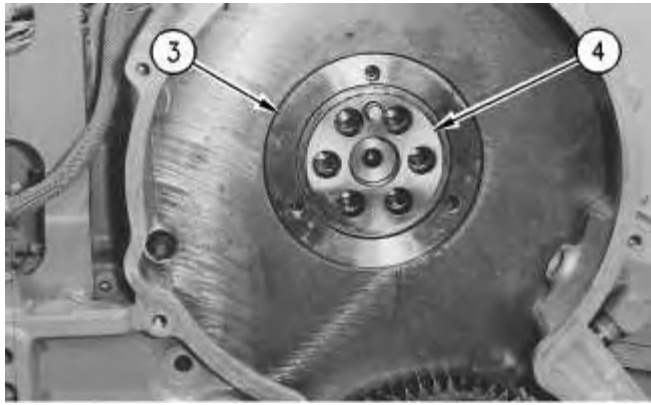

Illustration 2

g00576209

2. Remove seal assembly (3) and adapter (4) .

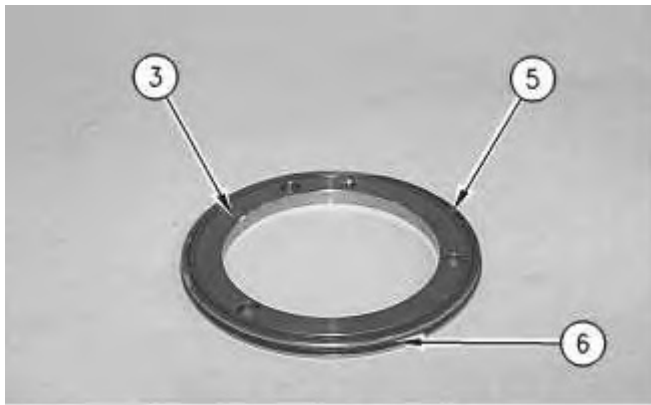

Illustration 3

g00576240

3. Remove O-ring seals (5) and (6) from seal assembly (3) .

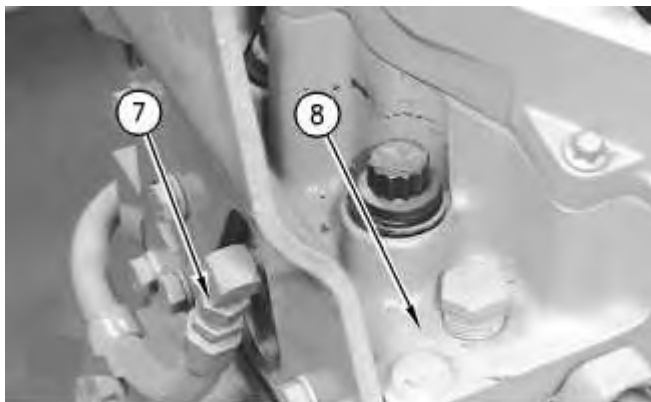

Illustration 4

g00580805

4. Disconnect hose assembly (7) from cylinder head (8) .

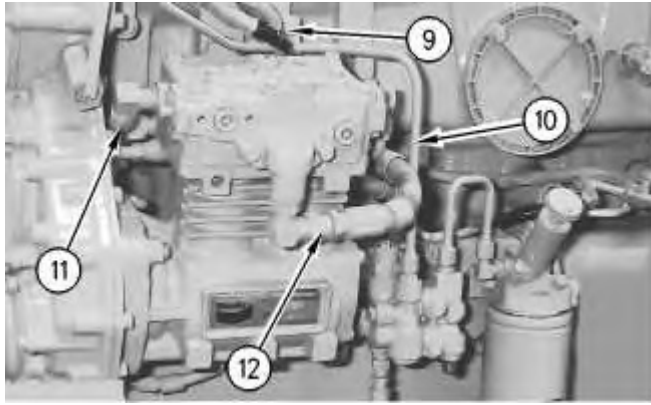

Illustration 5

g00580807

**Note:** If the engine is not equipped with an air compressor, skip Step 5.

5. Disconnect hose assemblies (11) and hose assemblies (12) from the air compressor.
6. Remove the bolt and clamp (9) from the hose assembly. Remove hose assembly (10) .

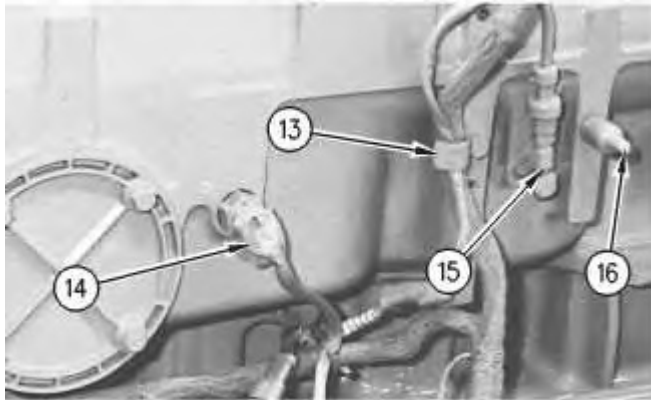

Illustration 6

g00580808

7. Remove the bolt and support clip (13) for the harness assembly.
  8. Disconnect the harness assembly from sensor (14) , sensor (15) , and ground stud (16) .
-

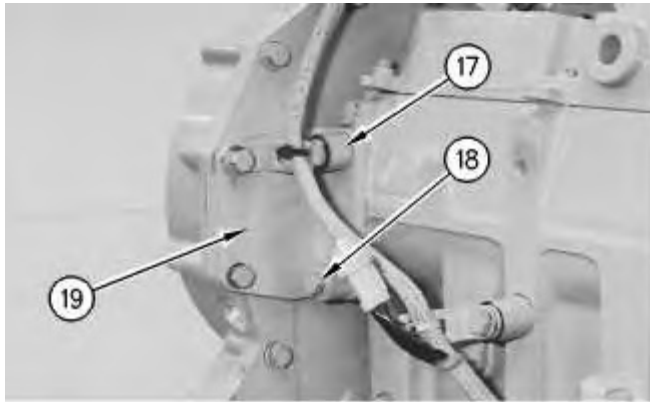

Illustration 7

g00580810

9. Remove bolts (18) and spacers (17) that fasten bracket (19) to the cylinder head.

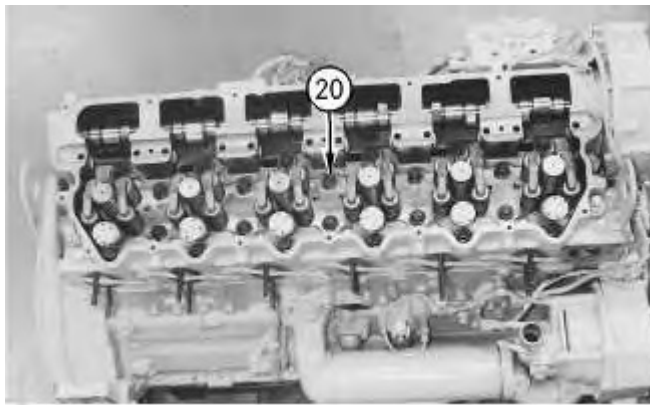

Illustration 8

g00580811

10. Remove cylinder head bolts (20) .

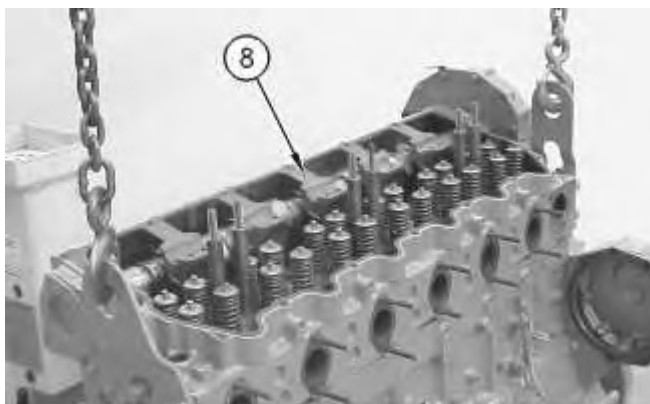

Illustration 9

g00580812

11. Attach a suitable lifting device to cylinder head (8) . Ensure that all of the following items are clear from the cylinder head: harness assemblies, tube assemblies and hose assemblies.
12. Carefully remove cylinder head (8) . The weight of the cylinder head is approximately 235 kg (518 lb).



Illustration 10

g00580833

13. Remove cylinder head gasket (21) .

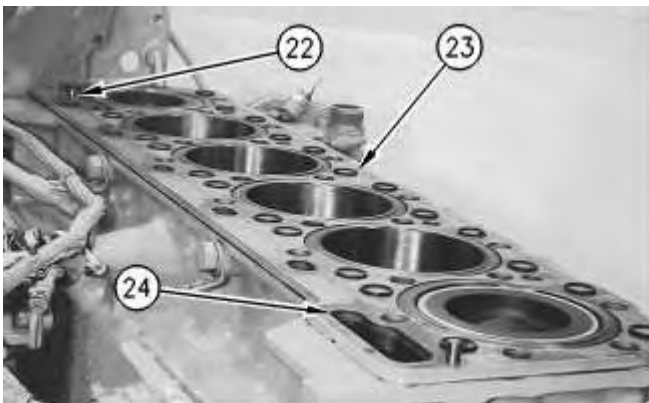

Illustration 11

g00632047

14. Remove O-ring seal (22) and water seals (23) . Remove seal (24) .
  15. Remove the spacer plate from the engine.
-



Illustration 12

g00632048

16. Remove spacer plate gasket (25) .



Illustration 13

g00632049

17. Remove O-ring seal (26) .

**Note:** If the cylinder head was removed from the cylinder block as a result of a failed head gasket, refer to Special Instruction, SEHS9564, "3400 Cylinder Head Joint Repair Procedure" for additional information.

---

Product: WHEEL DOZER

Model: 824C WHEEL DOZER 85X

Configuration: 824C TRACTOR 85X01194-UP (MACHINE) POWERED BY 3406 ENGINE

## Disassembly and Assembly 3406E and 3456 Engines for Caterpillar Built Machines

Media Number -REN1364-06

Publication Date -01/05/2008

Date Updated -20/05/2008

i07498909

# Cylinder Head - Install

SMCS - 1100-012

## Installation Procedure

Table 1

Required Tools			
Tool	Part Number	Part Description	Qty
A	-	Loctite Graphite 50 Anti-Seize	-
B	8T-2998	Lubricant	1
C	9S-3263	Thread Lock Compound	1

---

### NOTICE

**Keep all parts clean from contaminants.**

**Contaminants may cause rapid wear and shortened component life.**

---

**Note:** Thoroughly clean the spacer plate and the bottom surface of the cylinder head. A new spacer plate gasket must be installed when the cylinder head is removed.

---

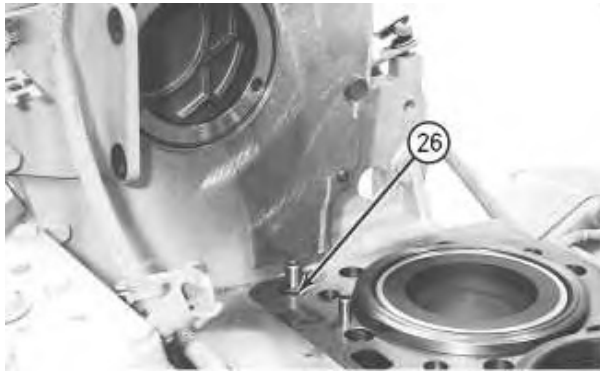

Illustration 1

g00632049

1. Apply a thin film of clean engine oil to O-ring seal (26). Install O-ring seal (26).



Illustration 2

g00632048

2. Install a new spacer plate gasket (25).
3. Install the spacer plate on the engine.

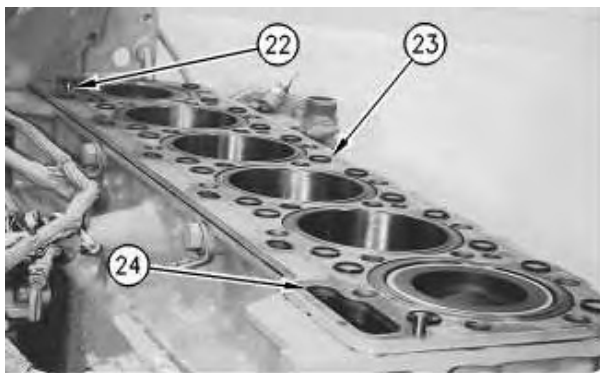

Illustration 3

g00632047

4. Apply a thin film of clean engine oil to O-ring seal (22). Install O-ring seal (22).
5. Install water seals (23) dry.
6. Install seal (24) in the spacer plate.

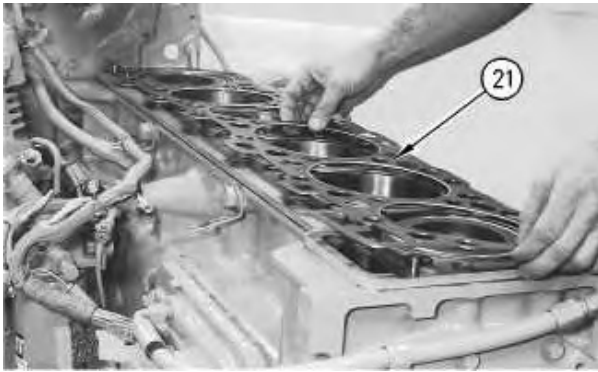

Illustration 4

g00580833

7. Install a new cylinder head gasket (21).

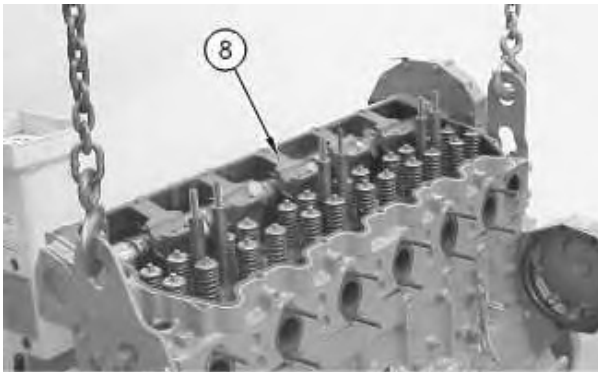

Illustration 5

g00580812

8. Attach a suitable lifting device to cylinder head (8). Carefully position cylinder head (8) on the spacer plate. The weight of the cylinder head is approximately 235 kg (518 lb).

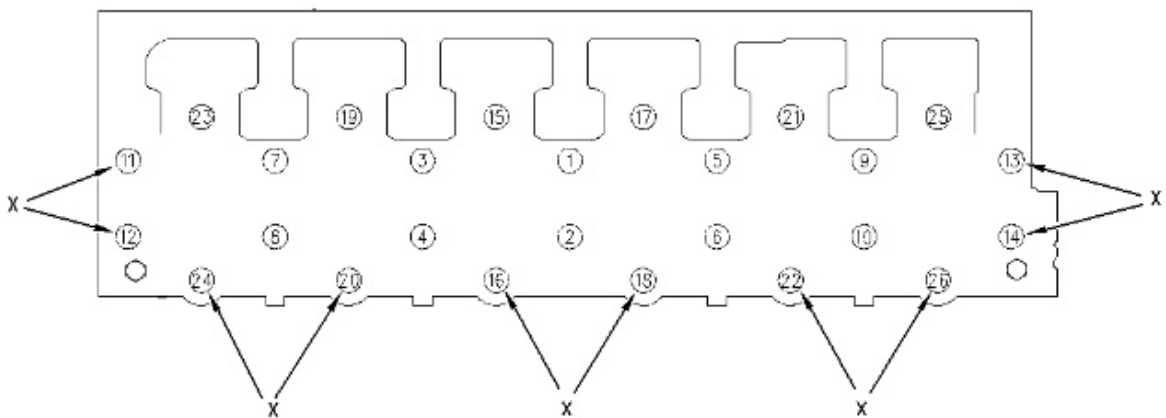

Illustration 6

g00513934

**Note:** The bolts that are Marked “X” are 216 mm (8.5 inch) long. The remainders of the bolts are 194 mm (7.6 inch) in length.

9. Apply a small amount of Tooling (A) to the bolt threads and both sides of the washers. Install the cylinder head bolts. Tighten the cylinder head bolts, as follows.
  - a. In a numerical sequence, tighten bolts 1 through 26 to a torque of  $270 \pm 15$  N·m ( $200 \pm 11$  lb ft).
  - b. In a numerical sequence, tighten bolts 1 through 26 to a torque of  $450 \pm 15$  N·m ( $330 \pm 11$  lb ft).
  - c. In a numerical sequence, again tighten bolts 1 through 26 to a torque of  $450 \pm 15$  N·m ( $330 \pm 11$  lb ft).

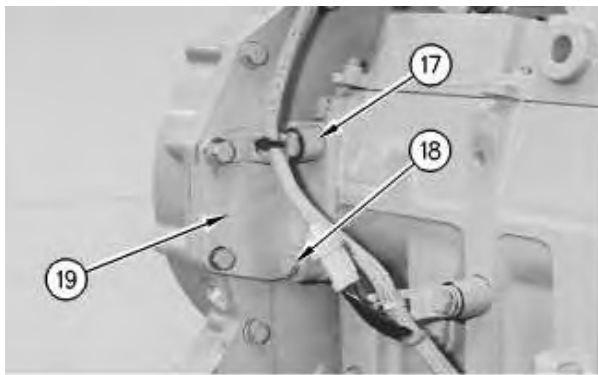

Illustration 7

g00580810

10. Install spacers (17) and bolts (18) that fasten bracket (19) to the cylinder head.

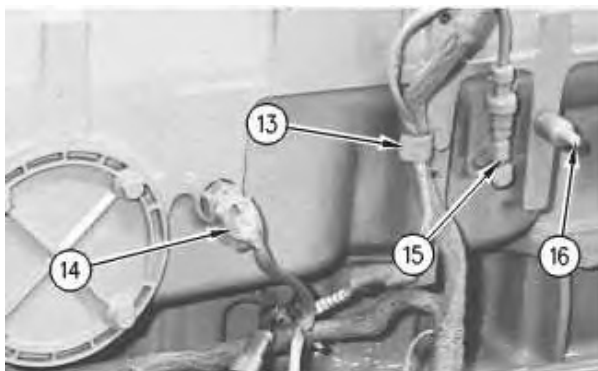

Illustration 8

g00580808

11. Connect the harness assembly to sensor (14), sensor (15), and ground stud (16).
  12. Install the bolt and support clip (13) for the harness assembly.
-

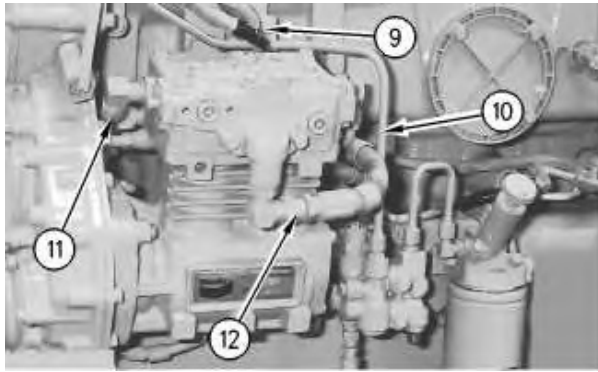

Illustration 9

g00580807

13. Install hose assemblies (10). Install the bolt and clamp (9).

**Note:** If the engine is not equipped with an air compressor, skip Step 14.

14. Connect hose assemblies (11) and hose assemblies (12) to the air compressor.

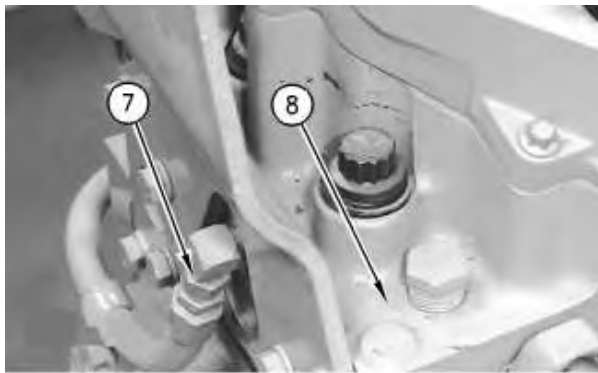

Illustration 10

g00580805

15. Connect hose assembly (7) to cylinder head (8).

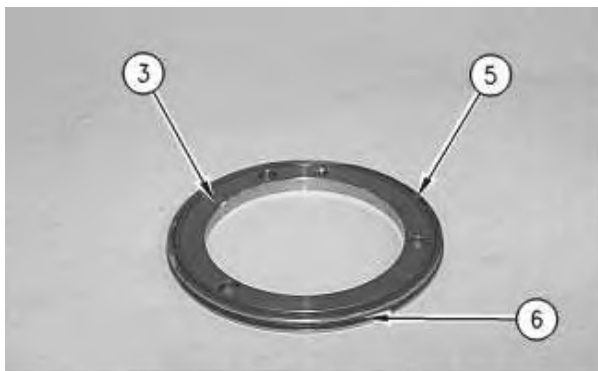

Illustration 11

g00576240

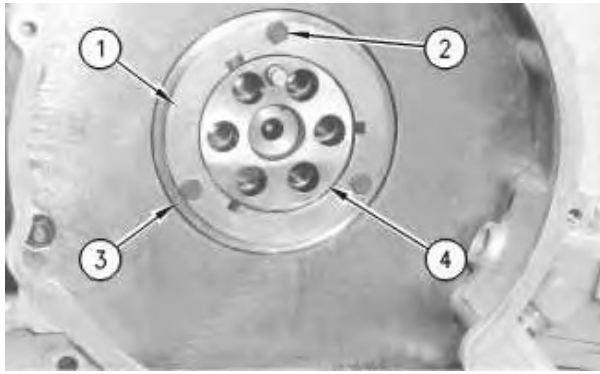

Illustration 12

g00576839

16. Install O-ring seals (5) and (6) in seal assembly (3). Lubricate seal (6) with Tooling (B).
17. Assemble thrust plate (1) and seal assembly (3). Apply Tooling (C) to bolts (2). Hold the assembly in position and install bolts (2). Evenly tighten bolts (2) until seal assembly (3) and O-ring seal (5) are seated against the cylinder head.

**Note:** Be careful to ensure that O-ring seal (5) stays in the groove in seal assembly (3).

18. Install adapter (4). Ensure that the dowel in adapter (4) engages the hole in the camshaft.

**End By:**

- a. Install the camshaft gear. Refer to Disassembly and Assembly, "Camshaft Gear - Remove and Install".
  - b. Install the electronic unit injectors. Refer to Disassembly and Assembly, "Electronic Unit Injector - Install".
  - c. Install the valve mechanism cover base. Refer to Disassembly and Assembly, "Valve Mechanism Cover Base - Remove and Install".
  - d. Install the exhaust manifold. Refer to Disassembly and Assembly, "Exhaust Manifold - Remove and Install".
  - e. Install the water temperature regulator. Refer to Disassembly and Assembly, "Water Temperature Regulator - Remove and Install".
-

Product: WHEEL DOZER

Model: 824C WHEEL DOZER 85X

Configuration: 824C TRACTOR 85X01194-UP (MACHINE) POWERED BY 3406 ENGINE

## Disassembly and Assembly 3406E and 3456 Engines for Caterpillar Built Machines

Media Number -REN1364-06

Publication Date -01/05/2008

Date Updated -20/05/2008

i02110801

### Camshaft - Remove

SMCS - 1210-011

### Removal Procedure

Table 1

Required Tools			
Tool	Part Number	Part Description	Qty
A	9U-7257	Cradle	1
B	9U-7256	Guide	1
C	9U-7225	Camshaft Pilot	2
D	9U-7240	Camshaft Hook	2

#### Start By:

- A. Remove the camshaft gear. Refer to Disassembly and Assembly, "Camshaft Gear - Remove and Install".
- B. Remove the rocker arms and the rocker shafts. Refer to Disassembly and Assembly, "Rocker Arm and Shaft - Remove".

---

#### NOTICE

**Keep all parts clean from contaminants.**

**Contaminants may cause rapid wear and shortened component life.**

---

---

## NOTICE

Care must be taken to ensure that fluids are contained during performance of inspection, maintenance, testing, adjusting and repair of the product. Be prepared to collect the fluid with suitable containers before opening any compartment or disassembling any component containing fluids.

Refer to Special Publication, NENG2500, "Caterpillar Tools and Shop Products Guide" for tools and supplies suitable to collect and contain fluids on Caterpillar products.

Dispose of all fluids according to local regulations and mandates.

---

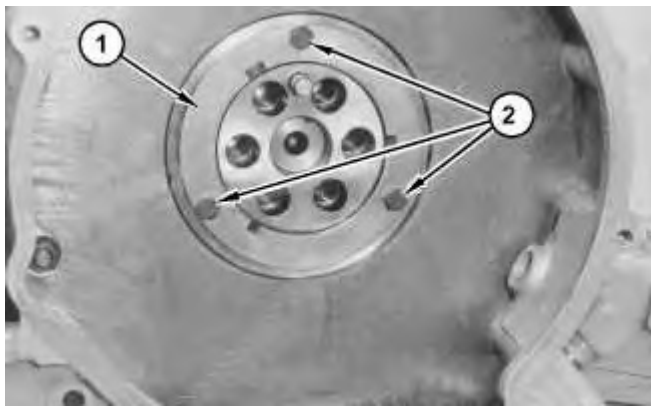

Illustration 1

g01028806

---

## NOTICE

**Do not turn the crankshaft or the camshaft while the camshaft gear is removed. If the front gear group is not correctly timed during installation, interference can occur between the pistons and the valves, resulting in damage to the engine.**

---

1. Remove bolts (2) and thrust plate (1) .
-

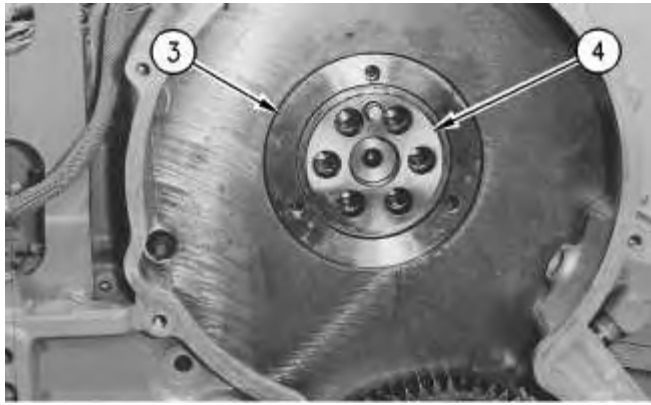

Illustration 2

g00576209

2. Remove seal assembly (3) and adapter (4) .

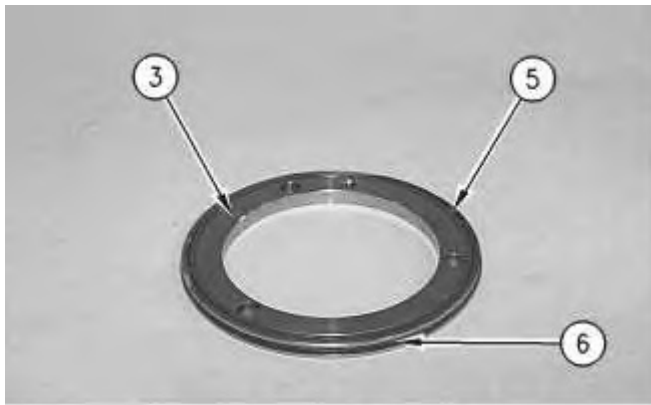

Illustration 3

g00576240

3. Remove O-ring seals (5) and (6) from seal assembly (3) .

---

## NOTICE

**Care must be used when removing the camshaft to not damage the highly finished surfaces of both the camshaft and camshaft bearings**

---

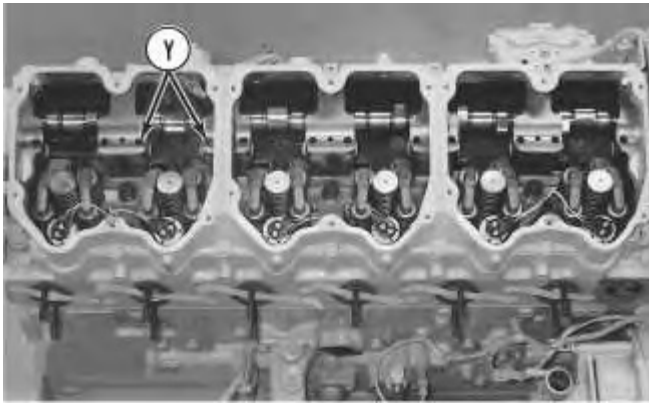

Illustration 4

g00509797

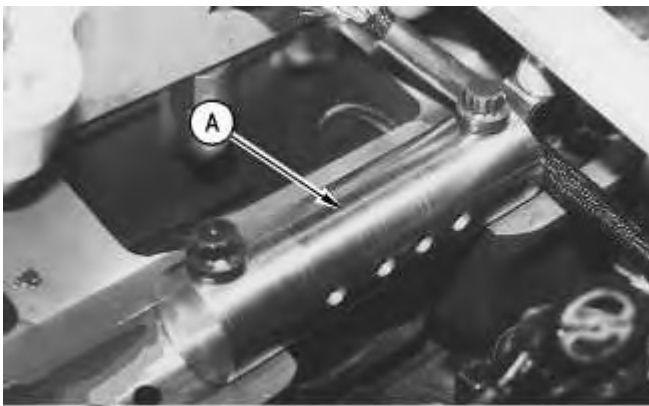

Illustration 5

g00581441

4. Use the bolts for the rocker arm shaft assembly to install Tooling (A) at Location (Y) .

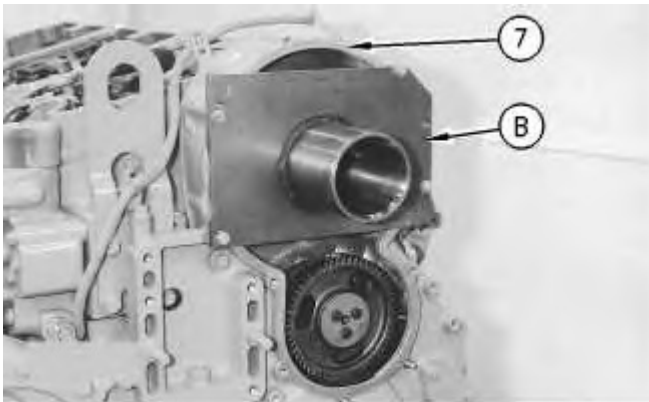

Illustration 6

g00581442

5. Install Tooling (B) on front housing (7). Do not tighten the bolts for Tooling (B) at this time.



**Suggest:**

**For more complete manuals. Please go to the home page.**

**<https://www.ebooklibonline.com>**

**If the above button click is invalid. Please download this document first, and then click the above link to download the complete manual.**

**Thank you so much for reading**

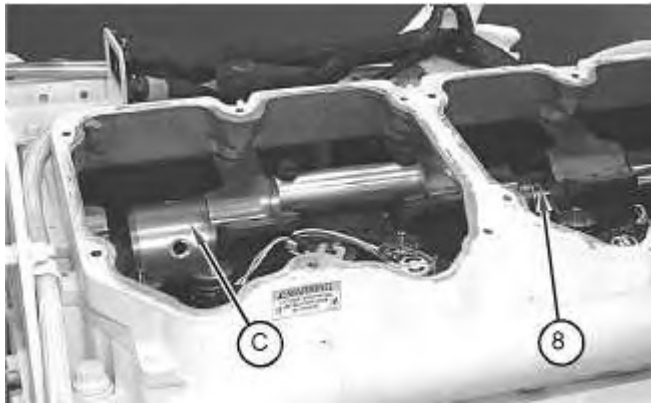

Illustration 7

g01074729

**Note:** It is necessary to install Tooling (C) on the camshaft. Tooling (C) will support the rear of camshaft (8) as the camshaft is moved out of the cylinder head and into Tooling (B) .

6. Move camshaft (8) forward and install one Tooling (C) in the end of camshaft (8). Again, move the camshaft forward and install remaining Tooling (C) into the back of first Tooling (C) .
7. Position camshaft (8) into the bore of Tooling (B). Tighten the bolts that hold Tooling (B) to the front housing.

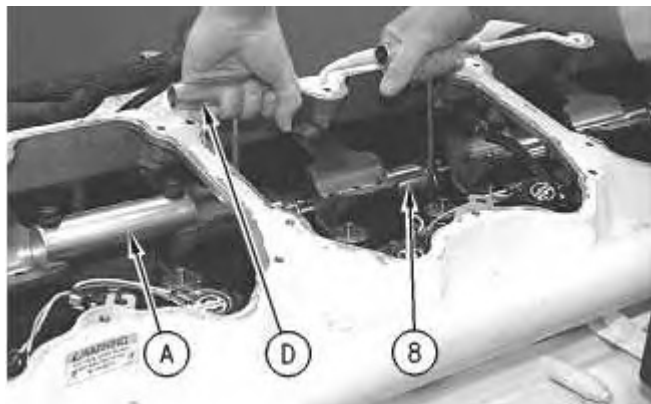

Illustration 8

g00581444

**Note:** Avoid lifting camshaft (8) with Tooling (D). The camshaft should rest on Tooling (A). Lifting of the camshaft can cause misalignment as the camshaft is removed, resulting in damage to the camshaft bearings.

---

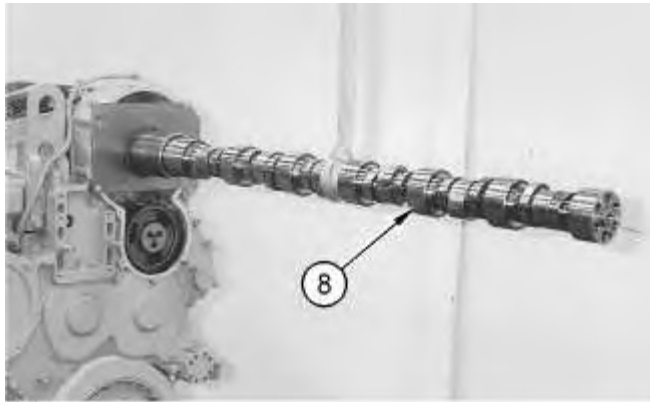

Illustration 9

g00581445

8. Remove camshaft (8), as follows:
  - a. Use Tooling (D) to move camshaft (8) toward the front of the engine. Reposition Tooling (D), as needed.
  - b. Move camshaft (8) far enough out of the cylinder head in order to attach a suitable lifting device.
  - c. Keep the camshaft level while the camshaft is being removed from the cylinder head. The weight of the camshaft is approximately 39 kg (86 lb).

## Alternative Removal Procedure

Table 2

Required Tools			
Tool	Part Number	Part Description	Qty
E <sup>(1)</sup>	177-8001	Sleeve	1
F	177-8002	Adapter	1
G	6L-4697	Bolts	3

<sup>(1)</sup> Part of 177-8003 Engine Tool Group

### Start By:

- A. Remove the camshaft gear. Refer to Disassembly and Assembly, "Camshaft Gear - Remove and Install".
- B. Remove the rocker arms and the rocker shafts. Refer to Disassembly and Assembly, "Rocker Arm and Shaft - Remove".

**Note:** This is an optional procedure to remove the camshaft. The preceding tool list shows the required tooling for removing the camshaft from the front of the engine or the rear of the engine.

---

**NOTICE**

**<https://www.ebooklibonline.com>**

Hello dear friend!

Thank you very much for reading.

Enter the link into your browser.

The full manual is available for immediate download.

**<https://www.ebooklibonline.com>**