

Product: WHEEL DOZER
 Model: 814 WHEEL DOZER 90P
 Configuration: 814 TRACTOR 90P00203-00358 (MACHINE)

Disassembly and Assembly
814-815-816 WHEEL TRACTOR & COMPACTOR POWER TRAIN

Media Number -REG01183-00

Publication Date -01/07/1972

Date Updated -14/08/2006

REG011830010

Differential And Carrier Assembly

SMCS - 3258-16; 3258-15

Disassemble Differential And Carrier Assembly

Tools Needed		A	B	C	D
1P2420	Transmission Repair Stand	1			
FT957	Differential Repair Positioning Group	1			
1P820	Hydraulic Puller Group		1		1
8B7557	Adpater		2		
8B7549	Leg		2		
1B4207	Nut		2		2
8B7560	Step Plate		1		
3H465	Plate		4		4
5F7343	Bearing Pulling Attachment			1	
1H3107	Push Puller			1	
1H3108	Leg			2	
7F9540	Hydraulic Puller			1	
8B7551	Bearing Pulling Attachment				1
1P490	Drive Plate				1
5F7369	Leg				2

start by:

a) remove differential and carrier assembly

1. Put the differential and carrier assembly on tool setup (A) with bevel gear down.

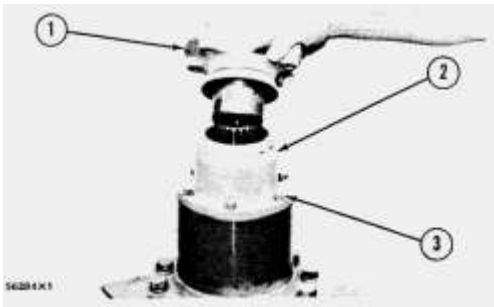

2. Remove the yoke (1).

3. Remove the bolts (3) and seal retainer (2). Remove the seal from retainer (2).

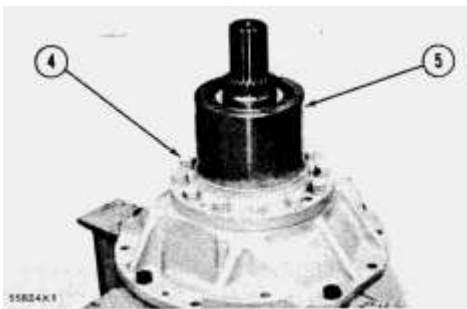

4. Remove the bolts (4) that hold cage (5) for bevel pinion to the carrier.

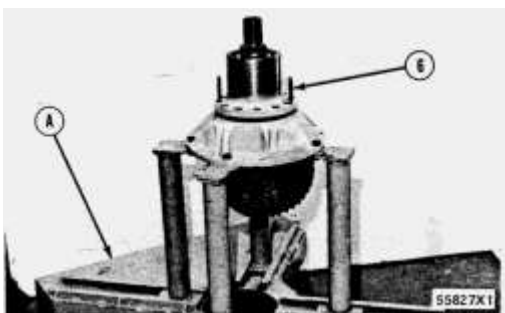

5. Install two 1/2"-13NC forcing screws (6), and loosen the cage (5) from carrier.

6. Remove the forcing screws, and install two 3/8"-16NC forged eyebolts.

7. Fasten a hoist and remove the bevel pinion shaft and cage assembly. Weight of assembly is 85 lb. (39 kg).

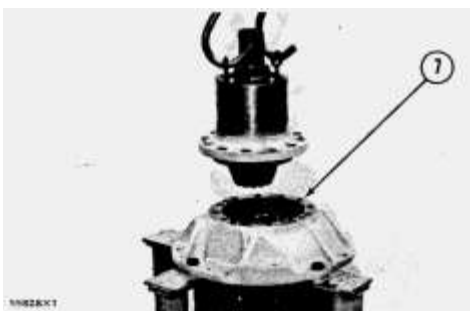

<https://www.ebooklibonline.com>

Hello dear friend!

Thank you very much for reading.

Enter the link into your browser.

The full manual is available for immediate download.

<https://www.ebooklibonline.com>

8. Remove and put identification on shims (7) for use during assembly of differential and carrier assembly.

9. Disassemble the bevel pinion shaft and cage assembly as follows:

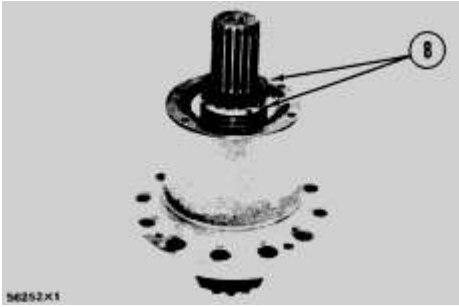

a) Remove the two spanner nuts (8) and lock.

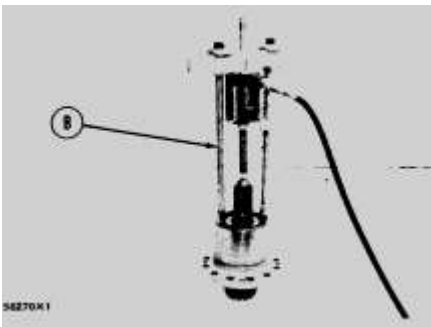

b) Install tool setup (B), and remove the pinion shaft from cage.

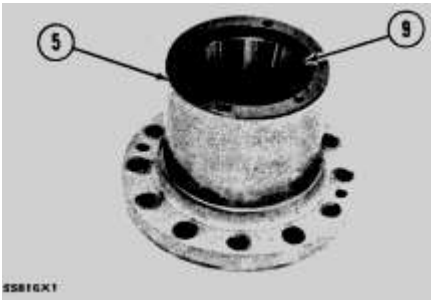

c) Remove the small bearing cone from cage (5). Remove bearing cups (9) from cage.

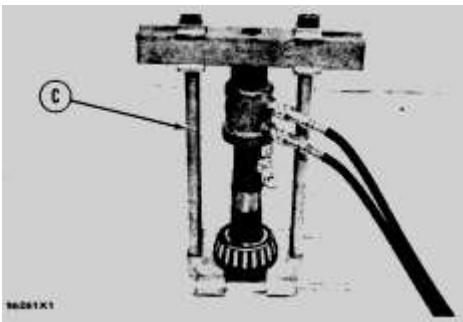

d) Install tool setup (C), and remove the large bearing cone from bevel pinion shaft.

10. Fasten a hoist and turn differential and carrier assembly over on stand (A) with bevel gear up.

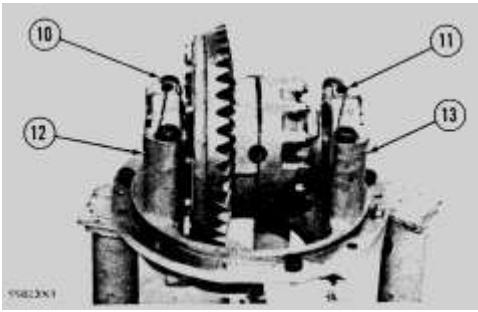

11. Remove the lockwire from bolts (11). Remove the bolts (11) and two locks.

12. Put identification marks on bearing caps (12) and (13) to make sure caps are installed back in their correct positions.

13. Remove the bolts (10) from bearing caps (12) and (13). Remove the bearing caps.

14. Put a bar through the differential. Fasten a hoist and remove the differential assembly. Weight of assembly is 135 lb. (61 kg).

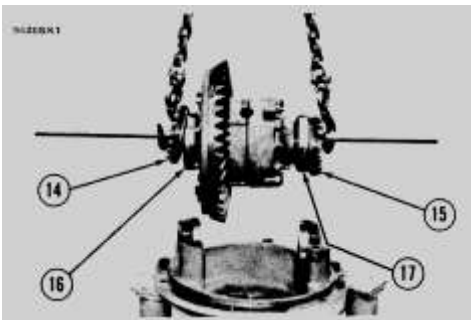

15. Remove adjusting rings (14) and (15).

16. Put identification marks on bearing cups (16) and (17) to make sure cups are installed with their respective bearing cones. Remove the bearing cups (16) and (17).

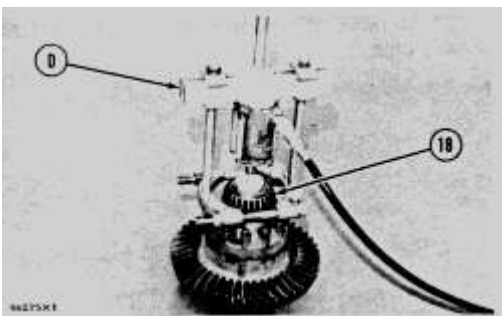

17. Install tool setup (D) and remove bearing cone (18) from differential.

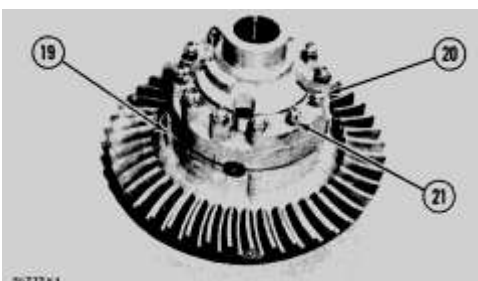

18. Put an alignment mark on cases (19) and (20) in the same place to make sure of correct alignment during assembly.

19. Remove cotter pins from nuts (21). Remove the nuts (21) and bolts.



20. Remove differential case (20).

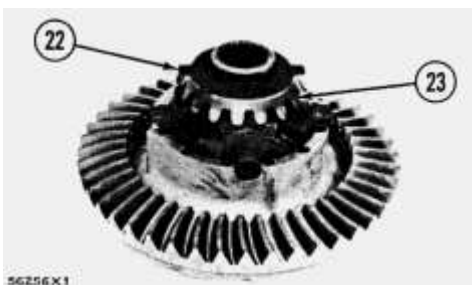

21. Remove thrust washer (22) and side gear (23).



22. Remove the pinions and spider (24) as a unit.

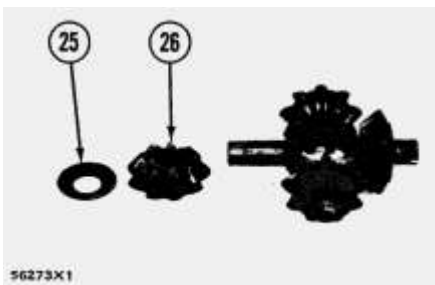

23. Remove the thrust washers (25) and pinions (26) from spider (24).

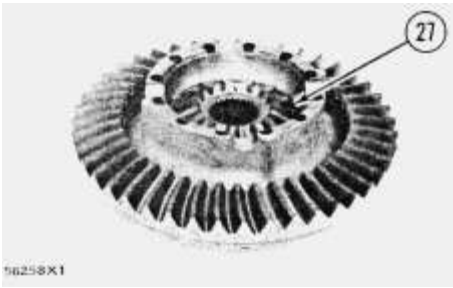

24. Remove the side gear (27) and thrust washer from differential case.

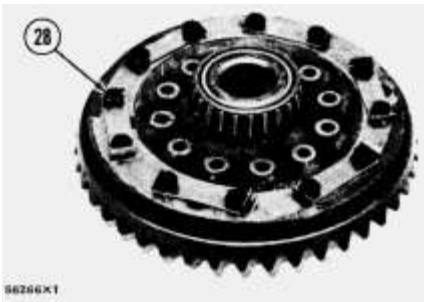

25. Remove the bolts (28), washers, and locks that hold bevel gear to differential case.

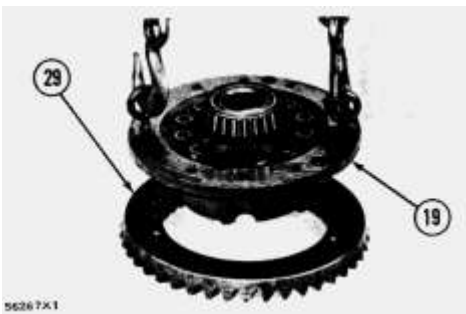

26. Make bevel gear (29) free of case (19).

27. Remove the differential case (19).

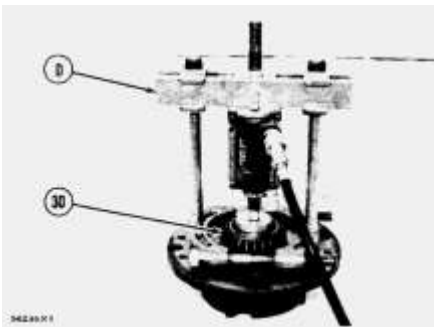

28. Install tool setup (D) and remove the bearing cone (30) from case.

Assemble Differential And Carrier Assembly

Tools Needed		A	B	C	D
1P2420	Transmission Repair Stand	1			
FT957	Differential Repair Positioning Group	1			
1P512	Drive Plate		1		
1P532	Handle		1		
6J4081	Bolt (1"–18NC x 13 in.)			1	
1B4333	Nut			1	
8S2328	Dial Test Indicator Group				1

1. Check to make sure flange of case and contacting surface of gear are clean and free of burrs.

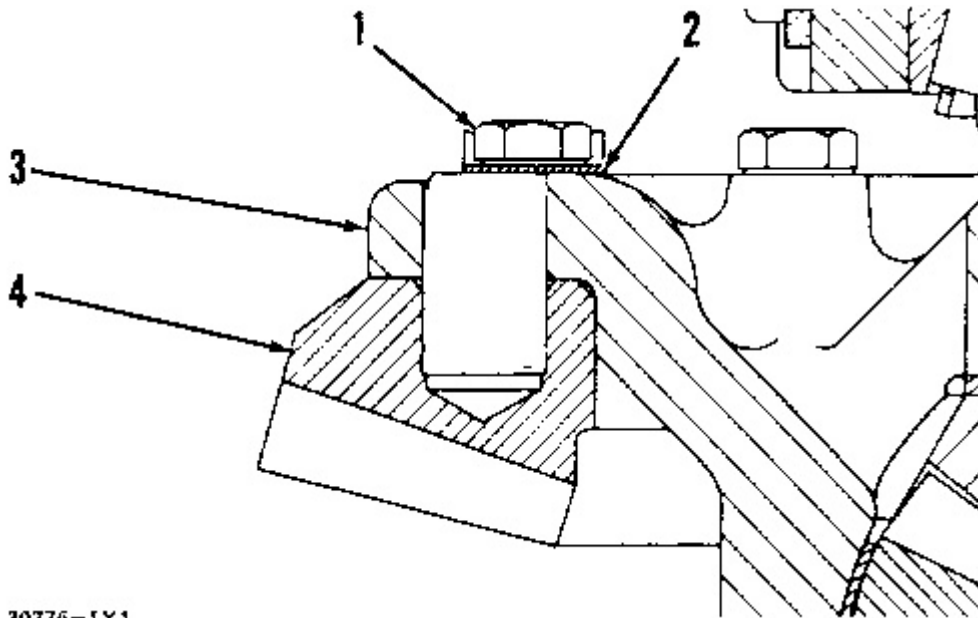

30776-1X1

2. Heat the bevel gear to a maximum temperature of 250°F (120°C). Install the bevel gear (4) on differential case (3).
3. Put oil on the threads of bolts (1) and on face of washers (2) that hold gear to case. Install the bolts, washers, and locks. Tighten all bolts the same amount until they have a torque of 98 ± 9 lb.ft. ($13,6 \pm 1,2$ mkg). Bend the locks.
4. If original bevel gear and cases are being used again, the dowels must fit tight in both the gear and the case. If the dowels do not fit tight, remove them. Install the larger service dowels using procedure in Step 5.
5. If a new bevel gear and/or cases are being installed, install the larger service dowels using following procedure:

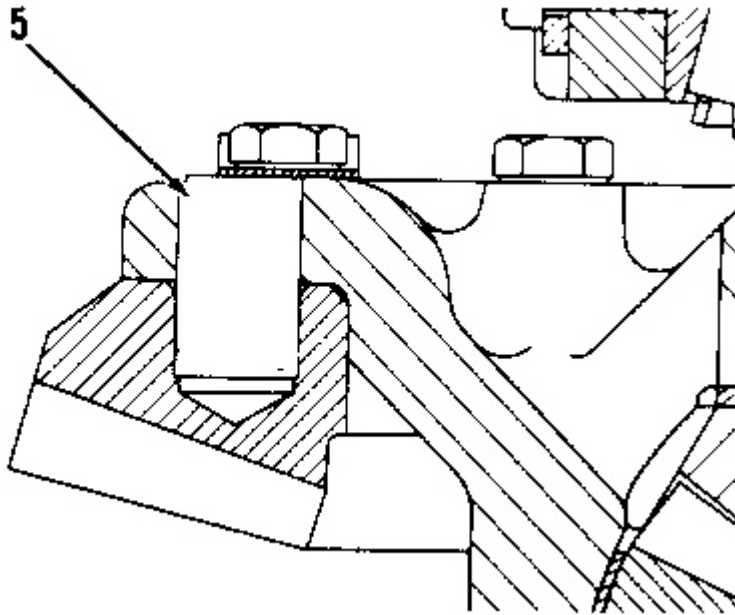

30776-1X2

- a) Make the original dowel holes (5) larger by using a .844 in. (21,4 mm) drill or a .875 in. (22,2 mm) core drill.
- b) Again, make the dowel holes larger by line reaming them to a diameter of .9045 to .9055 in. (22,9743 to 22,9997 mm). Use a standard .906 in. (23,1 mm) reamer to do this.

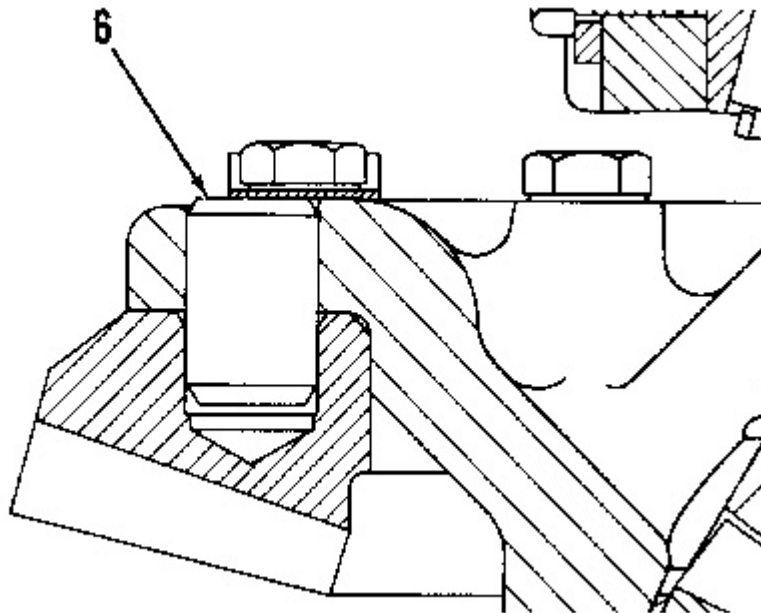

30776X1

- c) Install the three service dowels (6) even with face of differential case (3).

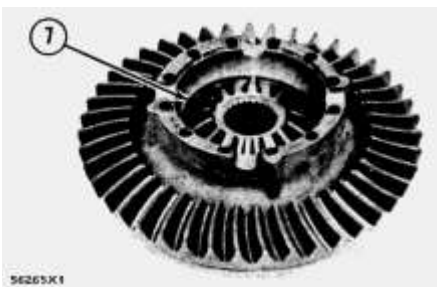

50205X1

6. Put oil on spider and pinion components. Install the thrust washers and side gear (7) in differential case (3) with the oil groove in thrust washer next to the side gear.

NOTICE

When replacing thrust washers for side gears and cup thrust washers, always replace the washers as a set and never one at a time.

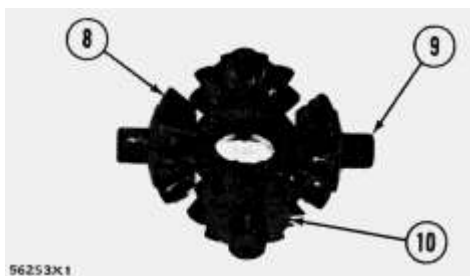

7. Install the cup thrust washers (10) and pinions (8) on spider (9).

8. Put the spider (9) in position in differential case (3).

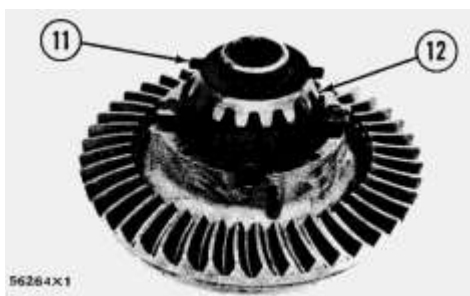

9. Install side gear (12) and thrust washer (11) with groove in washer next to the gear.



10. Put differential case (13) into position on case (3) with the marks on each case in alignment with each other. Install the bolts, nuts (14) and cotter pins.

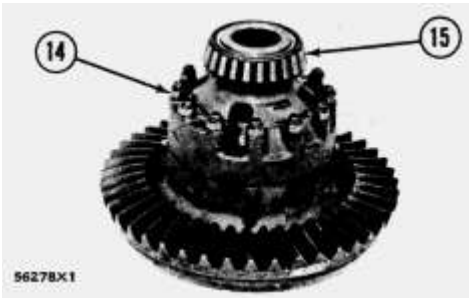

11. Heat the bearing cones of the differential assembly in oil to a maximum temperature of 275°F (135°C). Install the bearing cones (15) on the differential cases.

12. Assemble the bevel pinion shaft and cage assembly as follows:

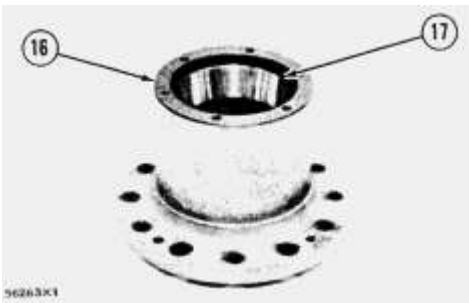

a) Install the bearing cups (17) in cage (16).

b) Heat the two bearing cones in oil at a maximum temperature of 275°F (135°C).

c) Install the larger bearing cone on the bevel pinion shaft.

d) Install pinion shaft in cage (16).

e) Install small bearing cone on shaft.

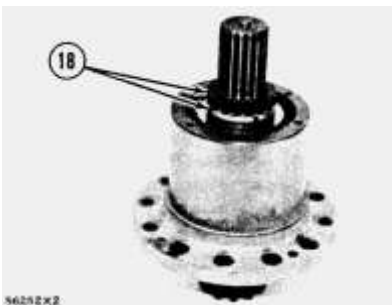

f) Install the two spanner nuts (18) and lock. Tighten nuts until a torque of 8 ± 2 lb.in. ($9,2 \pm 2,3$ cm.kg) is needed to turn the pinion shaft. Bend the lock.

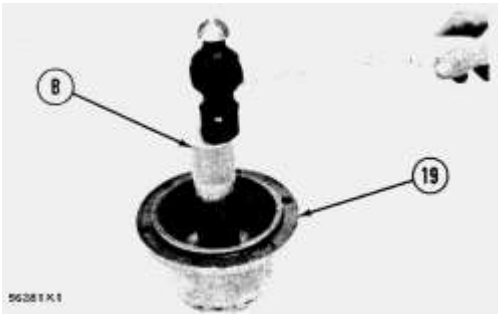

g) Use tool setup (B) to install seal in the retainer (19) with lip of seal toward the inside of retainer.

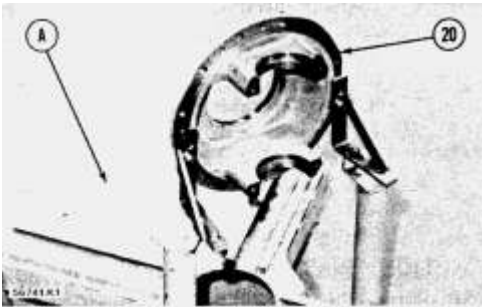

13. Fasten a hoist and put carrier assembly (20) on tool setup (A) as shown.

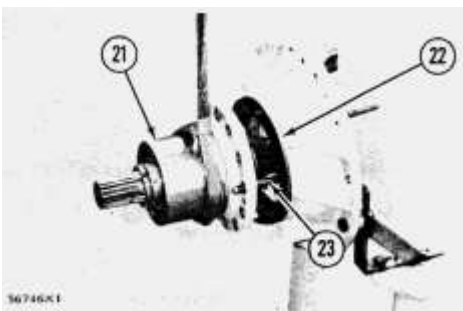

14. Install two 5/8"-11NC x 6 in. guide bolts (23) in carrier assembly. Install shims (22). As a starting point in finding correct bevel pinion location relative to bevel gear, install shims with thickness same as originally used.

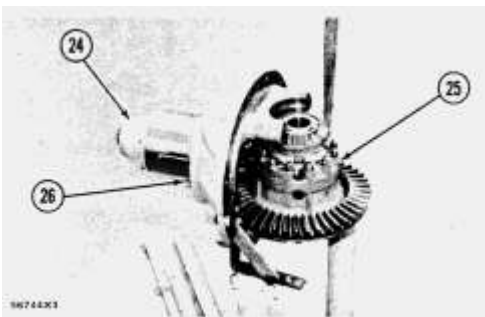

15. Fasten a hoist and put pinion shaft and cage assembly (21) in position. Install and tighten two mounting bolts (26). Install retainer (24).

16. Fasten a hoist and put differential assembly (25) in carrier in position shown. Install the bearing caps and bearing cups in their respective positions. Install upper and lower adjusting rings. Do not tighten bolts in bearing caps too tight, or adjusting rings can not be installed.

17. Make adjustment for differential bearing preload and for backlash (free motion between gears) between bevel gear and pinion using the following procedure:

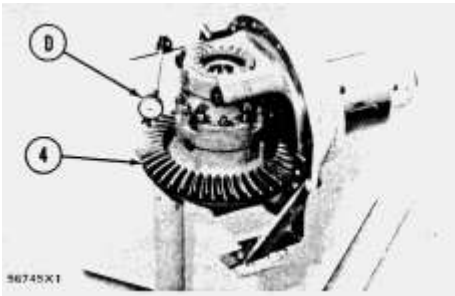

a) Install tool setup (D) on bevel gear as shown. Tighten lower adjusting ring until there is about .012 in. (0,30 mm) of backlash between bevel gear (4) and pinion. Remove the tool setup.

b) Remove the two bolts (26) from cage assembly. Install a 5/8"-11NC x 6 in. bolt (28). Slide cage assembly (21) free of gear (4).

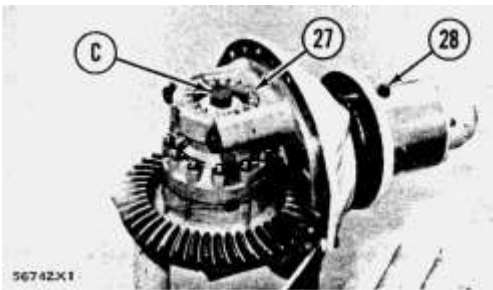

c) Install tool setup (C) and suitable flat washers. Tighten upper adjusting ring (27) until bearing preload can be felt. Using a torque wrench and tool setup (C), check the torque needed to turn differential assembly. Tighten or loosen adjusting ring (27) until 30 ± 5 lb.in. ($34,5 \pm 5,8$ cm.kg) of torque is needed to turn differential assembly.

d) Slide cage assembly (21) back into position and install the two bolts. Install tool setup (D) and check backlash of gear at four different places. Use lowest reading as the backlash value. Backlash must be .008 to .017 in. (0,20 to 0,43 mm).

e) If backlash is too much, loosen upper adjusting ring (27) and tighten lower adjusting same amount. If backlash is not enough, loosen lower ring and tighten upper ring the same amount.

NOTICE

Differential bearing preload will be kept only if the loosening of one ring is followed by the tightening of other ring by same amount.

18. Tighten four bolts in the bearing caps.

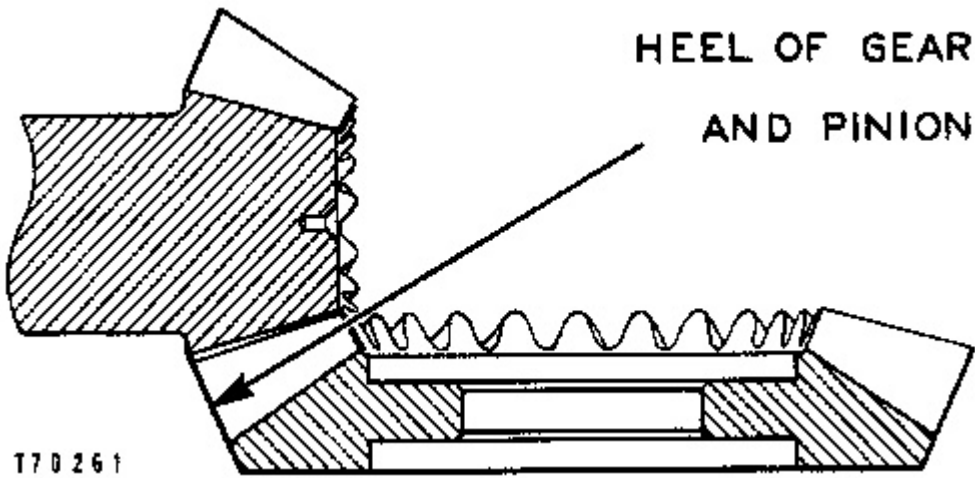

ALIGNING BEVEL GEAR AND PINION

19. After backlash and bearing preload adjustments have been made, check tooth contact setting between bevel gear and pinion using the following procedure:

a) Put small amount of prussian blue, red lead, or paint on bevel gear teeth. Turn pinion and check marks made on bevel gear teeth.

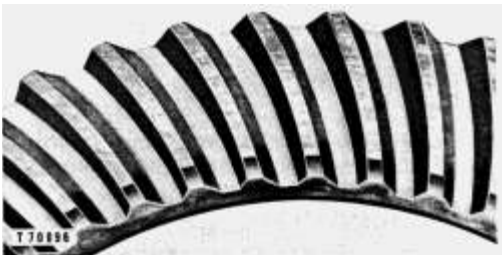

CORRECT TOOTH CONTACT SETTING

b) With no load, correct tooth contact setting will be as shown. The area of contact starts near toe of gear and goes about 30% up the length of tooth. With this setting, when load is put on gear, it will be over the correct area of teeth.

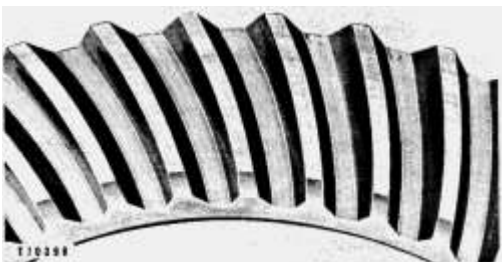

SHORT TOE CONTACT SETTING

c) If bevel pinion shaft is too far away from bevel gear, short toe contact will result as shown. The teeth of pinion will be in contact with toe ends of convex faces and top edge of heel end of concave faces. To correct this, move pinion shaft toward gear by decreasing shim thickness between pinion cage and carrier. After doing this, check backlash and tooth contact again.

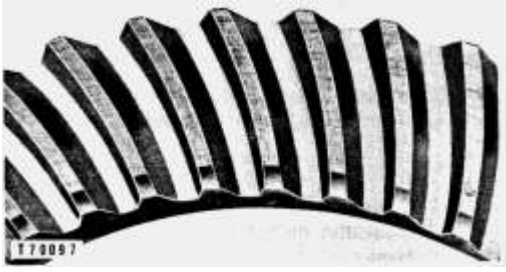

SHORT HEEL CONTACT SETTING

d) If bevel pinion shaft is too near to center of bevel gear, short heel contact will result as shown. The teeth of pinion will be in contact with toe ends of concave faces and the heel ends of convex faces. To correct this, move pinion shaft away from gear by increasing shim thickness between pinion cage and carrier. After doing this, check backlash and tooth contact again.

NOTE: Several adjustments of both pinion and bevel gear may be necessary before correct tooth contact setting and backlash is made. Always remember that a change in backlash will also change the tooth contact setting. Therefore, be sure backlash is in correct adjustment before checking tooth contact.

e) After correct backlash and tooth contact setting is made, remove extra prussian blue, red lead, or paint from gear and pinion.

20. Install locks and bolts for adjusting rings. Put lockwire on the four bolts for bearing caps. Remove the two guide bolts, and install remainder of bolts that hold cage assembly. Remove differential and carrier assembly from tool setup (A). Install the yoke.

end by:

a) install differential and carrier assembly

Product: WHEEL DOZER
Model: 814 WHEEL DOZER 90P
Configuration: 814 TRACTOR 90P00203-00358 (MACHINE)

Disassembly and Assembly

814-815-816 WHEEL TRACTOR & COMPACTOR POWER TRAIN

Media Number -REG01183-00

Publication Date -01/07/1972

Date Updated -14/08/2006

REG011830011

Engine, Torque Converter, And Transmission

SMCS - 1004-12; 1004-11

Remove Engine, Torque Converter, And Transmission

start by:

- a) remove radiator and guard assembly
- b) remove air cleaner assembly
1. Remove the oil from transmission.
2. Remove air cleaner elbow assembly.

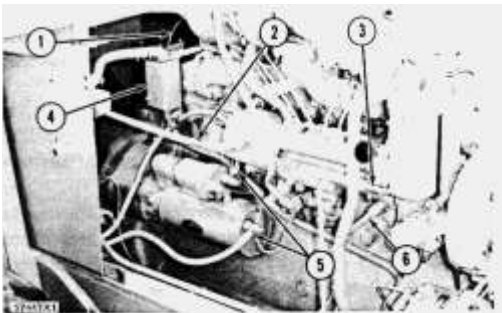

3. Disconnect control linkage (2) from the governor. Disconnect glow plug wiring from wiring harness.
4. Remove cover (4) from junction box, and disconnect the wiring. Pull the wiring free of the engine.
5. Disconnect the wiring (5) from starter. Remove sensing line (1) for oil pressure from engine.
6. Disconnect fuel inlet line (6), fuel return line (3), and fuel pressure sensing line from engine.



Suggest:

For more complete manuals. Please go to the home page.

<https://www.ebooklibonline.com>

If the above button click is invalid. Please download this document first, and then click the above link to download the complete manual.

Thank you so much for reading

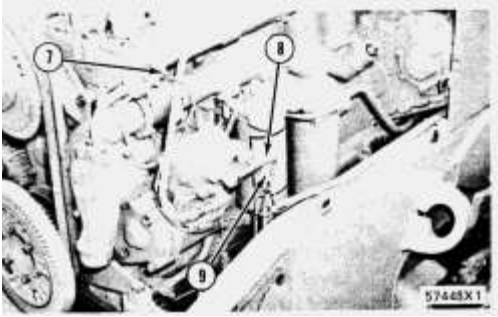

7. Disconnect sensing line (7) for water temperature from engine. Disconnect air supply line (8) from air compressor. Disconnect sensing line (9) from air compressor governor.

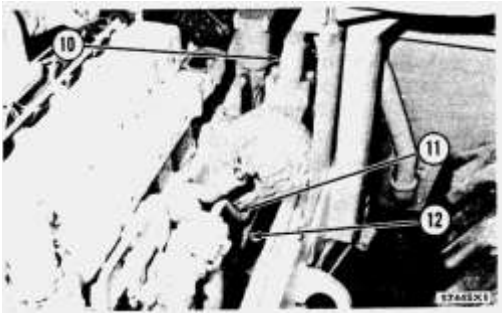

8. Disconnect the oil lines (11) and (12) from transmission oil cooler.

9. Remove the oil inlet line (10) for the steering and implement pump.

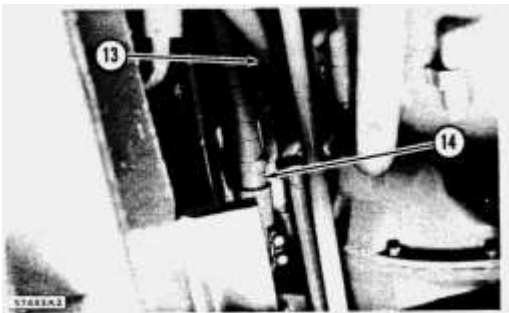

10. Disconnect the oil outlet lines (13) and (14) from the pump. Pull the lines free of the engine.

11. Remove the firewall and two floor plates.

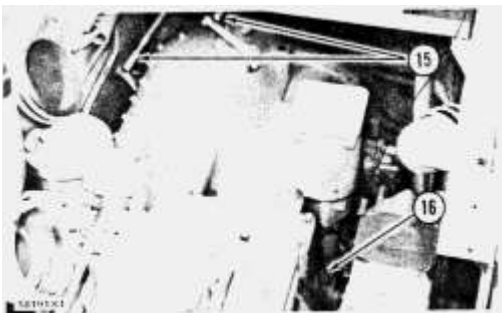

12. Disconnect the sending unit (16) for oil temperature for torque converter from torque converter.

13. Disconnect the control linkage (15) from the transmission.

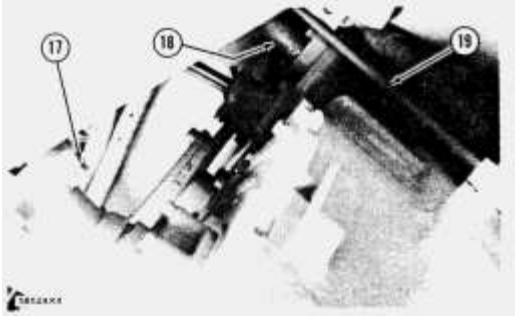

14. Remove the oil filler pipe (18) from the transmission.

15. Disconnect the oil level gauge (19) from the transmission.

16. Remove the bolts (17) that fasten the front drive shaft to the transmission. Move the drive shaft away from transmission.

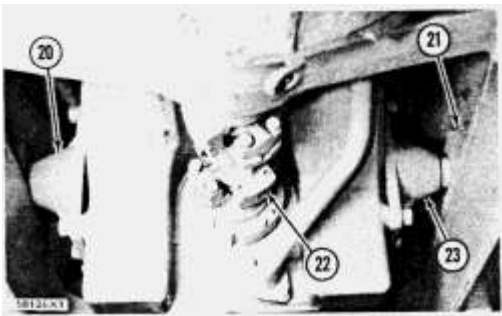

17. Remove the rear drive shaft (22).

18. Install a 5/8"-11NC forged eyebolt in the top of torque converter housing.

19. Fasten a hoist to the engine and torque converter. Loosen the bolts that fasten the caps (21) to frame. Remove the bolts that fasten the supports (20) and (23) to transmission. Pull the supports away from transmission.

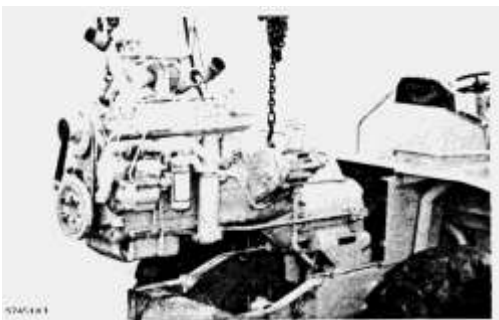

20. Remove the engine, torque converter, and transmission as a unit. Weight of unit is 4000 lb. (1800 kg).

NOTE: The engine, torque converter, and transmission must be kept level in order to remove them from the machine.

Install Engine, Torque Converter, And Transmission

<https://www.ebooklibonline.com>

Hello dear friend!

Thank you very much for reading.

Enter the link into your browser.

The full manual is available for immediate download.

<https://www.ebooklibonline.com>