



# Service Repair Manual

## **Models**

# M325D MH EXCAVATOR

---

[Previous Screen](#)

Product: EXCAVATOR

Model: M325D MH EXCAVATOR EDF

Configuration: M325D L Material Handler EDF02000-UP (MACHINE) POWERED BY C7 Engine

## Disassembly and Assembly M325D Material Handler Machine Systems

Media Number -REN9719-02

Publication Date -01/03/2011

Date Updated -16/03/2011

i02334435

# Swing Motor - Disassemble

SMCS - 5058-015-ZW

## Disassembly Procedure

Table 1

Required Tools			
Tool	Part Number	Part Description	Qty
A	1U-7506	Mounting Adapter Gp	1
	8T-4244	Nut	6
	8T-4223	Hard Washer	6
	-	Threaded Rod (M12 by 1.75 by 150 mm)	1
B	6V-7887	Puller Leg	2
	5F-7344	Puller Block	1
	1P-0074	Slide Hammer Puller Gp	1
	5P-4750	Adjustment Screw	1
C	8T-0651	Bolt	2
	8T-4167	Hard Washer	2
D	1P-1853	Retaining Ring Pliers	1
E	9S-9152	Bearing Puller Gp	1
	1P-0510	Driver Gp	1

**Start By:**

A. Remove the swing motor. Refer to Disassembly and Assembly, "Swing Motor - Remove".

**Note:** Cleanliness is an important factor. Before the disassembly procedure, the exterior of the component should be thoroughly cleaned. This will prevent dirt from entering the internal mechanism.

**Note:** If a failure occurs, an accurate diagnosis of the cause can prevent a recurrence. Information is available to analyze failures for piston motors. Refer to Special Publication, SEBD0641, "Analyzing Axial Piston Pump and Motor Failures".

**Note:** Inspect all parts. If any parts are worn or damaged use new parts for replacement. The installation of used parts during reconditioning is acceptable. Reuse and salvage information is available on piston motors. Refer to Guideline For Reusable Parts and Salvage Operations, SEBF8032, "Piston Pumps and Motors". During reconditioning, correct any conditions that might have caused the original failure.

---

## NOTICE

**Keep all parts clean from contaminants.**

**Contamination of the hydraulic system with foreign material will reduce the service life of the hydraulic system components.**

**To prevent contaminants from entering the hydraulic system, always plug or cap the lines, fittings, or hoses as they are disconnected. Cover any disassembled components and clean them properly before assembly.**

**Clean the hydraulic system properly after any major component exchange or especially after a component failure, to remove any contamination.**

---

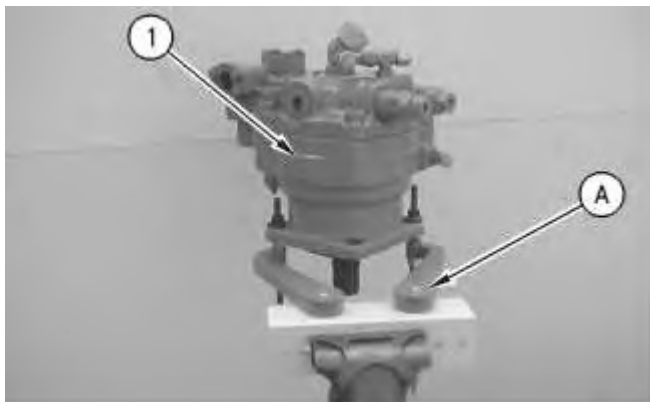

Illustration 1

g00877535

1. Install swing motor (1) to Tooling (A) .

**<https://www.ebooklibonline.com>**

Hello dear friend!

Thank you very much for reading.

Enter the link into your browser.

The full manual is available for immediate download.

**<https://www.ebooklibonline.com>**

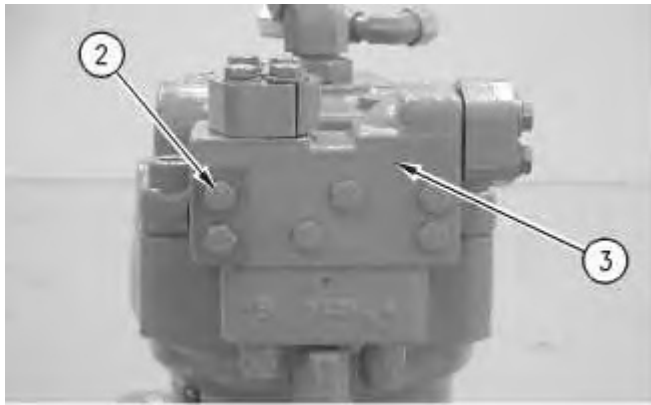

Illustration 2

g00877536

2. Remove bolts (2). Remove anti-reaction valve (3) from the head.



Illustration 3

g00877537

3. Remove relief valves (4) from the head.
-

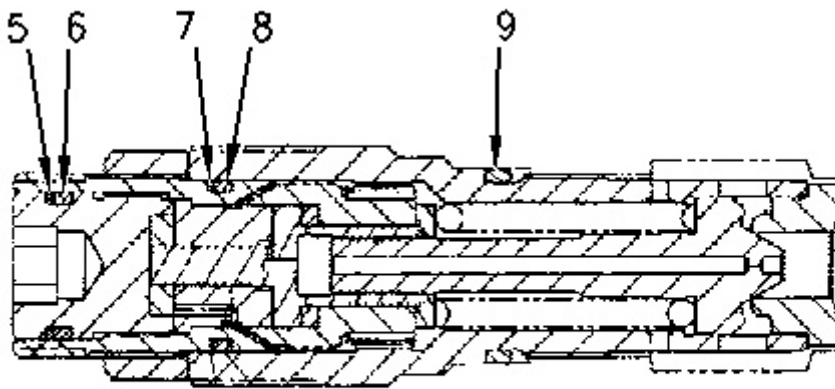

Illustration 4

g00877538

4. Remove O-ring seals (6), (8), and (9). Remove backup rings (5) and (7) .

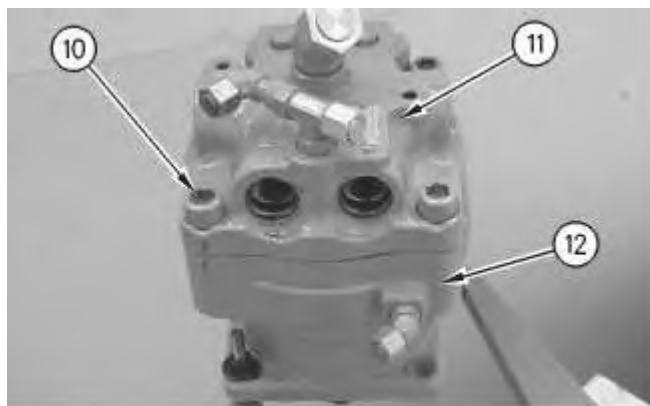

Illustration 5

g00877539

**! WARNING**

**Personal injury can result from being struck by parts propelled by a released spring force.**

**Make sure to wear all necessary protective equipment.**

**Follow the recommended procedure and use all recommended tooling to release the spring force.**

5. Remove bolts (10) .
6. Remove head (11) from motor housing (12) .

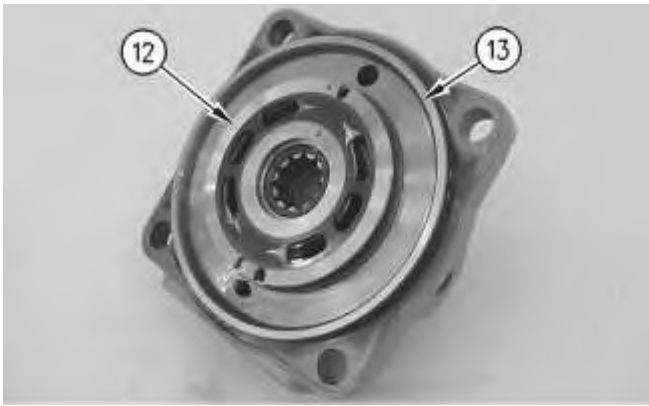

Illustration 6

g00877540

7. Remove plate (12) and O-ring seal (13) .

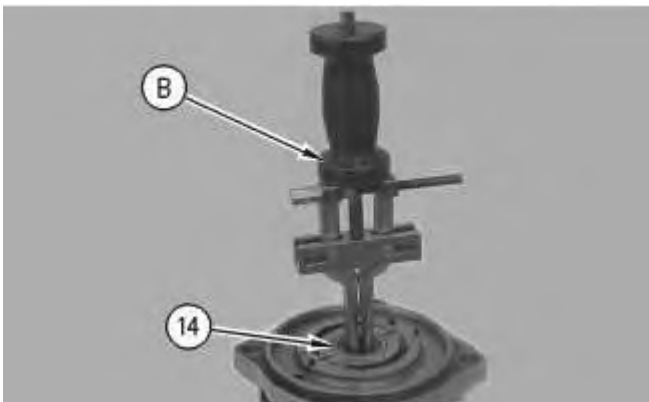

Illustration 7

g00877541

8. Install Tooling (B) and remove bearing (14) .
-



Illustration 8

g00877542

 **WARNING**

**Personal injury can result from being struck by parts propelled by a released spring force.**

**Make sure to wear all necessary protective equipment.**

**Follow the recommended procedure and use all recommended tooling to release the spring force.**

9. Remove plug (15) and the O-ring seal.

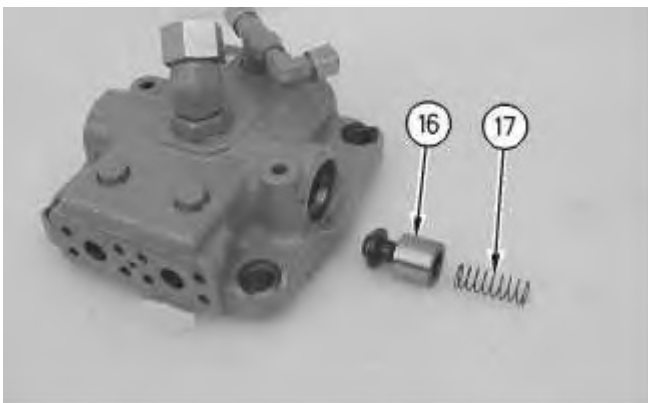

Illustration 9

g00877544

10. Remove spring (17) and valve (16) .



Illustration 10

g00877545

11. Remove springs (18) .

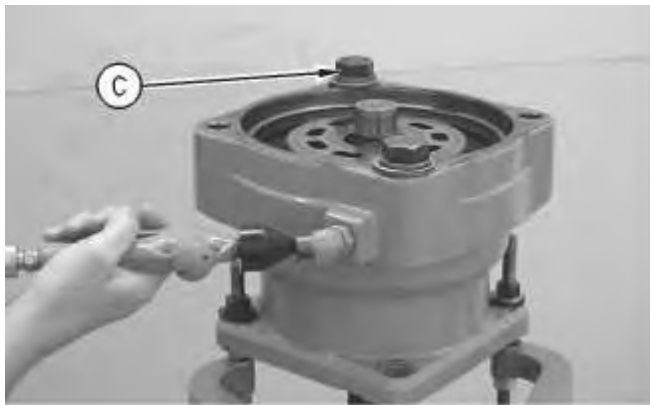

Illustration 11

g00877546

12. Install Tooling (C). Apply air pressure in order to unseat the piston.

**Note:** Use air pressure in order to avoid damage to the piston.

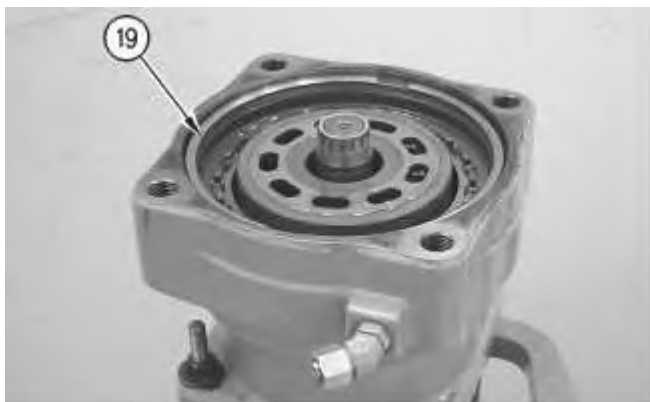

Illustration 12

g00877547

13. Remove piston (19) .

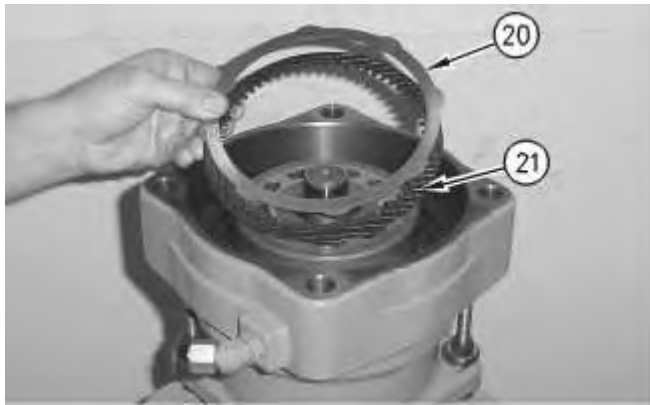

Illustration 13

g00877548

14. Remove steel plates (20). Remove plates (21) .



Illustration 14

g00877549

15. Remove barrel (22) and the pistons as an assembly.



16. Mark pistons (23) .
17. Remove pistons (23) from barrel (22) .



18. Remove pistons (23) from plates (24) and (25) .

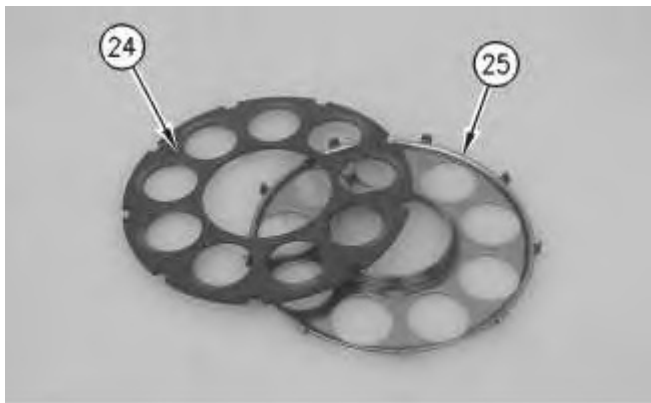

19. Separate plates (24) and (25) .
-

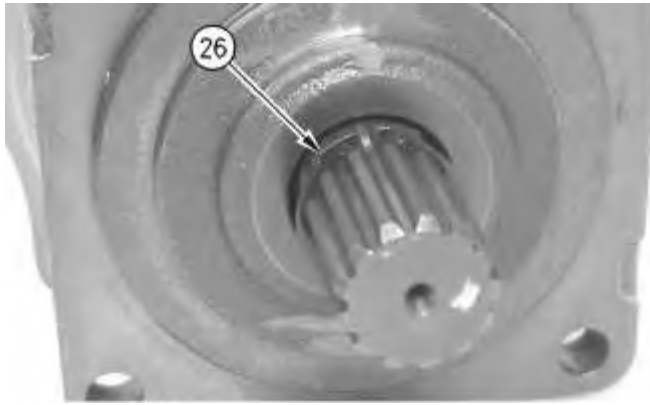

Illustration 18

g00877584

20. Use Tooling (D) in order to remove retaining ring (26) .

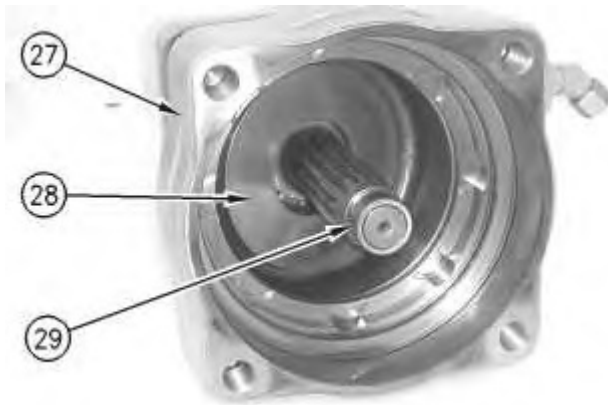

Illustration 19

g00877585

21. Remove plate (28) and shaft (29) from housing (27) .

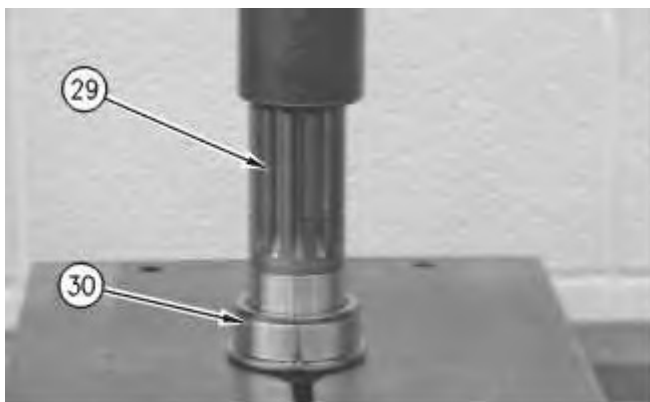

Illustration 20

g00877586

22. Use a suitable press to remove bearing race (30) from shaft (29) .



Illustration 21

g00877587

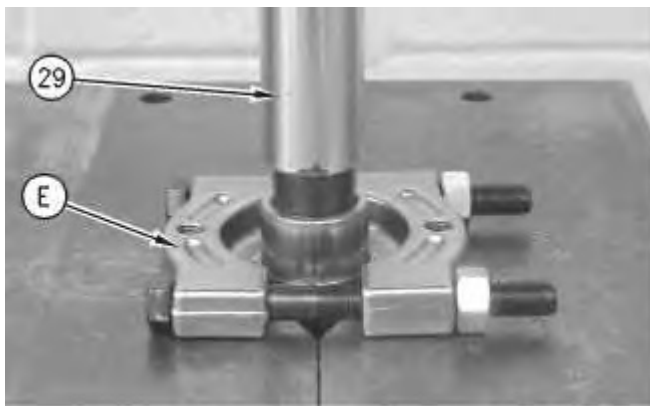

Illustration 22

g00877588

23. Use Tooling (E) and a suitable press to remove bearing race (31) from shaft (29) .



Illustration 23

g00877589

24. Remove O-ring seal (32) from housing (27) .



Illustration 24

g00877628

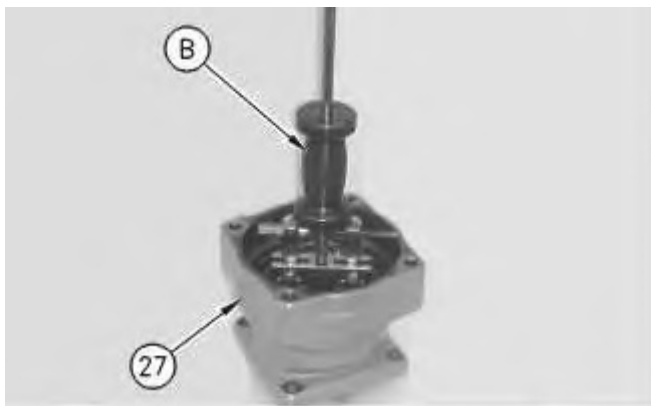

Illustration 25

g00877629

25. Install Tooling (B). Remove bearing (32) from housing (27) .

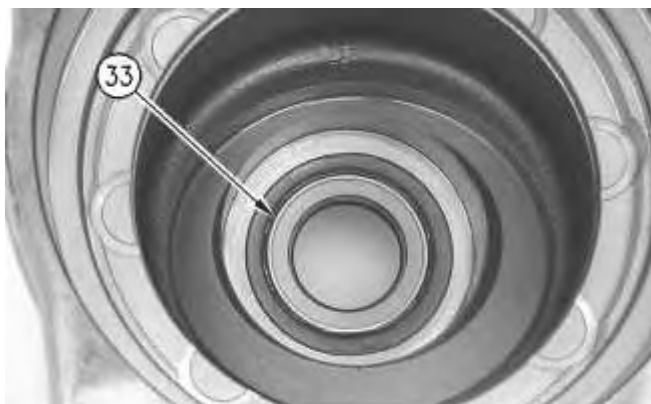

Illustration 26

g00877630

26. Remove seal (33) from the housing.

[Previous Screen](#)

Product: EXCAVATOR

Model: M325D MH EXCAVATOR EDF

Configuration: M325D L Material Handler EDF02000-UP (MACHINE) POWERED BY C7 Engine

## Disassembly and Assembly M325D Material Handler Machine Systems

Media Number -REN9719-02

Publication Date -01/03/2011

Date Updated -16/03/2011

i02334439

# Swing Motor - Assemble

SMCS - 5058-016-ZW

## Assembly Procedure

Table 1

Required Tools			
Tool	Part Number	Part Description	Qty
D	1P-1853	Retaining Ring Pliers	1
F	1U-6396	O-Ring Assembly Compound	1

**Note:** Cleanliness is an important factor. Before assembly, all parts should be thoroughly cleaned in cleaning fluid. Allow the parts to air dry. Wiping cloths or rags should not be used to dry parts. Lint may be deposited on the parts which may cause later trouble. Inspect all parts. If any parts are worn or damaged, use new parts for replacement. All disassembly and all assembly procedures must be performed on a clean work surface and in a clean hydraulic area. Keep cleaned parts covered and protected at all times.

**Note:** O-ring seals, gaskets, and seals should always be replaced. A used O-ring seal may not have the same sealing properties as a new O-ring seal. Use Tooling (F) during the assembly procedure.

**Note:** Apply a light film of hydraulic oil to all components before assembly.

**Note:** If a failure occurs, an accurate diagnosis of the cause can prevent a recurrence. Information is available to analyze failures for piston pumps and motors. Refer to Special Publication, SEBD0641, "Analyzing Axial Piston Pump and Motor Failures".

**Note:** Inspect all parts. If any parts are worn or damaged use new parts for replacement. The installation of used parts during reconditioning is acceptable. Reuse and salvage information is available on piston pumps. Refer to Guideline For Reusable Parts and Salvage Operations, SEBF8032, "Piston Pumps and Motors". During reconditioning, correct any conditions that might have caused the original failure.

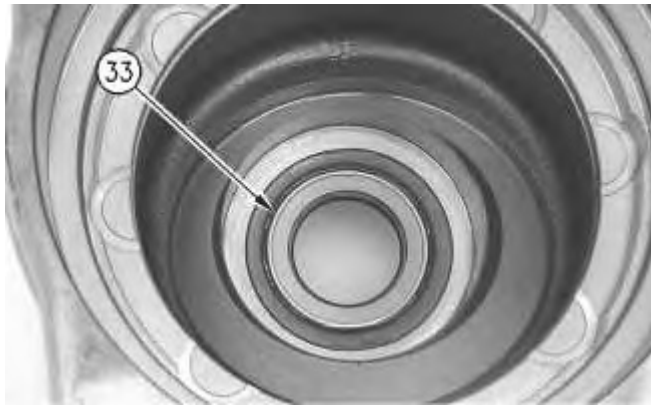

Illustration 1

g00877630

1. Install seal (33) into the housing.



Illustration 2

g00877628

2. Lower the temperature of bearing (32) .
3. Install bearing (32) into the housing.



4. Install O-ring seal (32) into housing (27) .



---

Illustration 4

5. Raise the temperature of bearing race (31). Install bearing (31) onto the shaft.

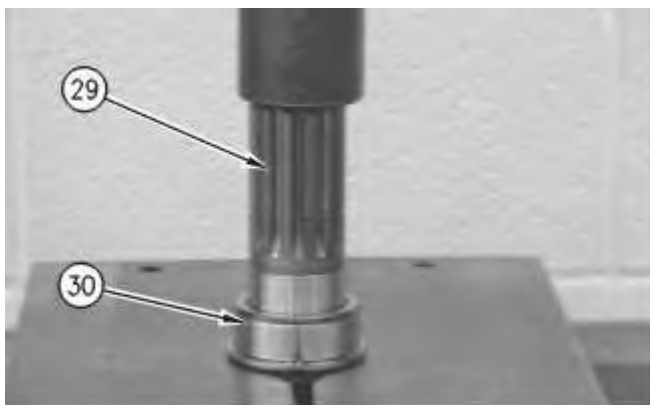

---

Illustration 5

6. Raise the temperature of bearing race (30). Install bearing (30) onto shaft (29) .
-

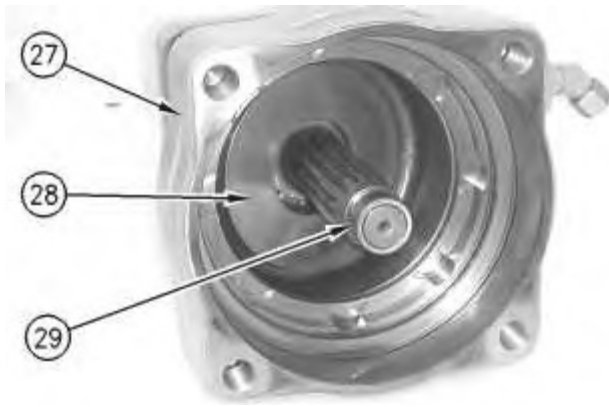

Illustration 6

g00877585

7. Install shaft (29) and plate (28) into housing (27) .

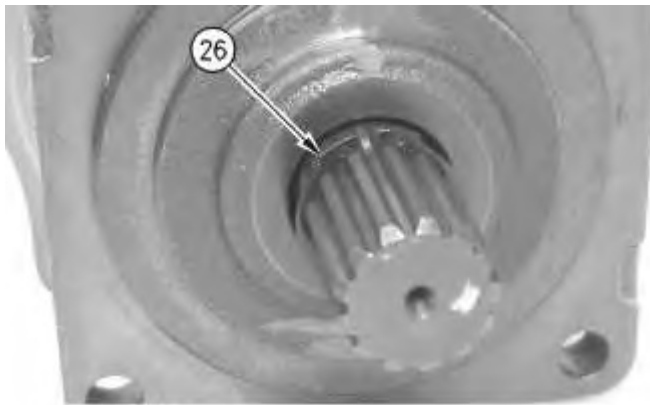

Illustration 7

g00877584

8. Use Tooling (D) in order to install retaining ring (26) .

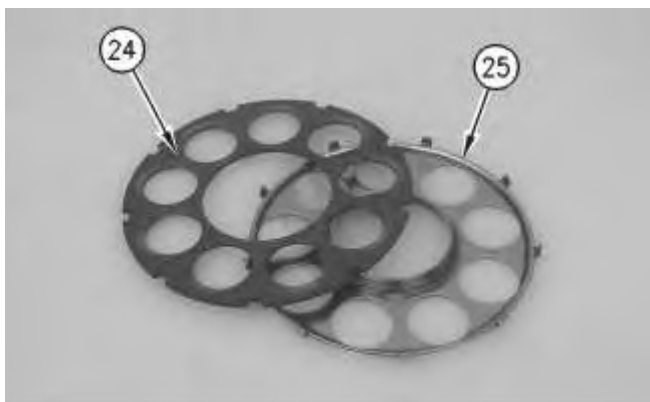

Illustration 8

g00877583

9. Reassemble plates (24) and (25) .



Illustration 9

g00877551

10. Install pistons (23) into plates (24) and (25) .

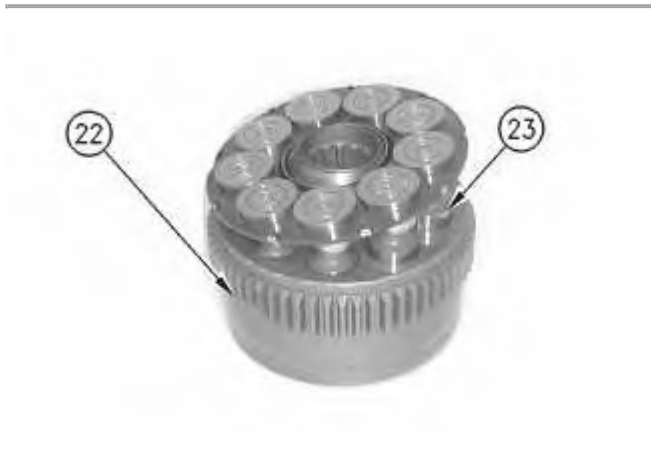

Illustration 10

g00877550

11. Install pistons (23) into barrel (22) .



12. Install barrel (22) and the pistons as an assembly.

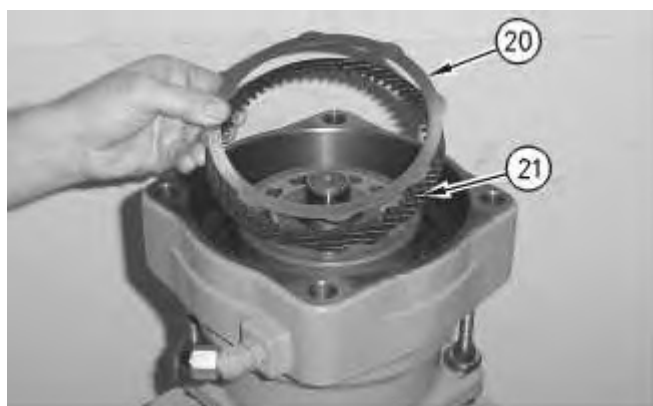

Illustration 12

13. Install steel plates (20). Install plates (21) .

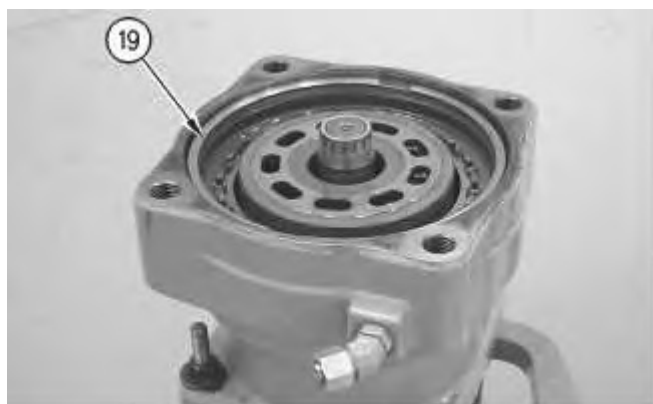

Illustration 13

14. Install piston (19) .
-



Illustration 14

g00877545

15. Install springs (18) .

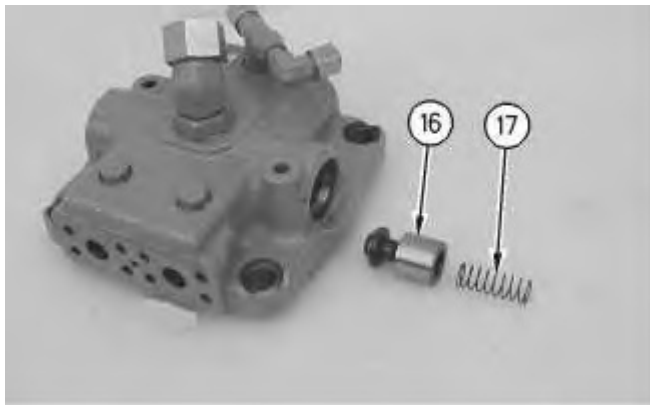

Illustration 15

g00877544

16. Install valve (16) and spring (17) .



Illustration 16

g00877542

## **WARNING**

**Improper assembly of parts that are spring loaded can cause bodily injury.**

**To prevent possible injury, follow the established assembly procedure and wear protective equipment.**

---

17. Install the O-ring seal and plug (15) .

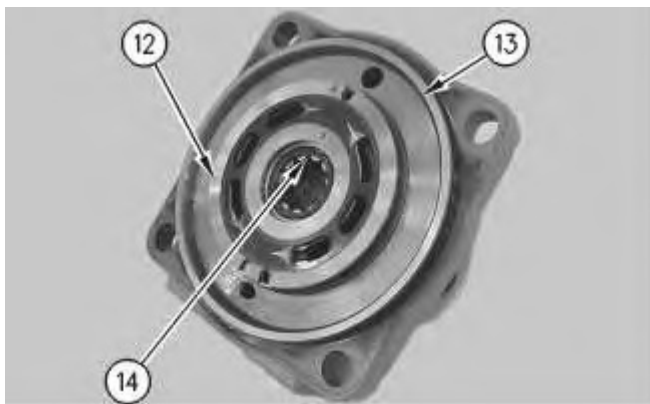

Illustration 17

g00877795

18. Lower the temperature of bearing (14). Install bearing (14) .
19. Install O-ring seal (13) and plate (12) .

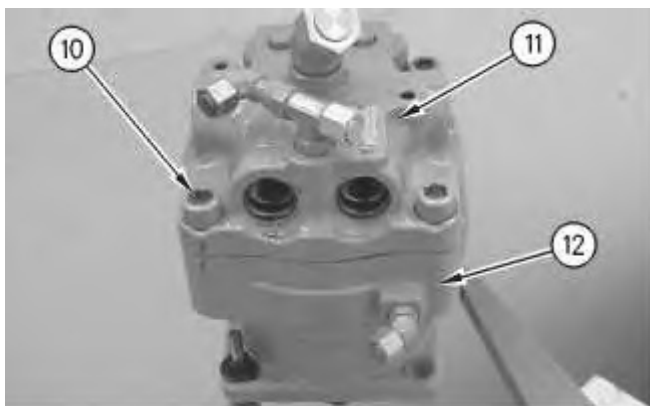

Illustration 18

g00877539

**! WARNING**

**Improper assembly of parts that are spring loaded can cause bodily injury.**

**To prevent possible injury, follow the established assembly procedure and wear protective equipment.**

- 
20. Position head (11) onto motor housing (12) .
  21. Install bolts (10) .
  22. Tighten bolts (10) to a torque of  $431 \pm 43 \text{ N}\cdot\text{m}$  ( $318 \pm 32 \text{ lb ft}$ ).

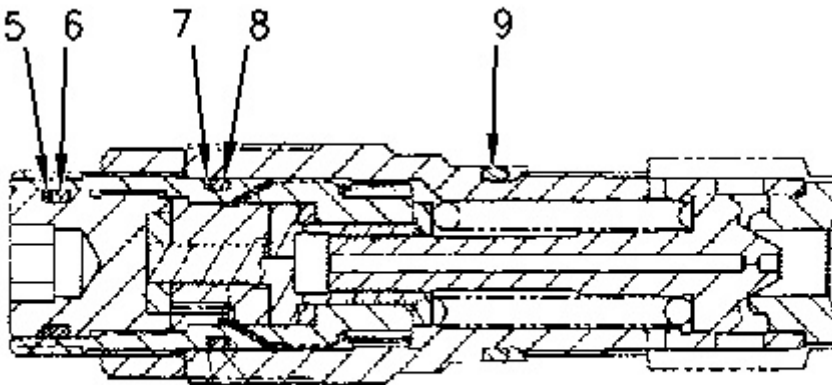

---

Illustration 19

g00877538

23. Install backup up rings (5) and (7). Install O-ring seals (6), (8), and (9) .
-



**Suggest:**

**If the above button click is invalid.**

**Please download this document**

**first, and then click the above link**

**to download the complete manual.**

**Thank you so much for reading**



Illustration 20

g00877537

24. Install relief valves (4) from the head.
25. Tighten relief valves (4) to a torque of 177 N·m (130 lb ft).

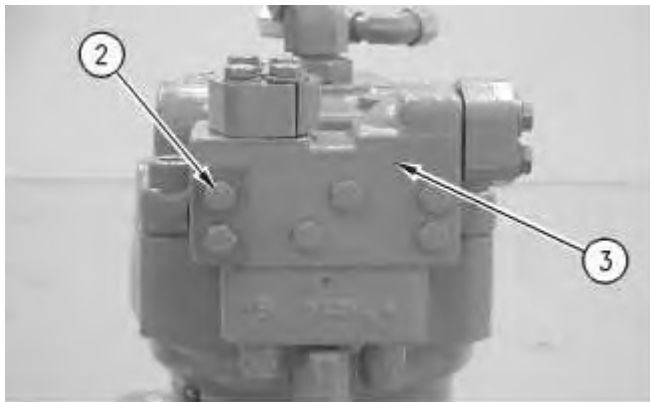

Illustration 21

g00877536

26. Position anti-reaction valve (3) onto the head. Install bolts (2) .

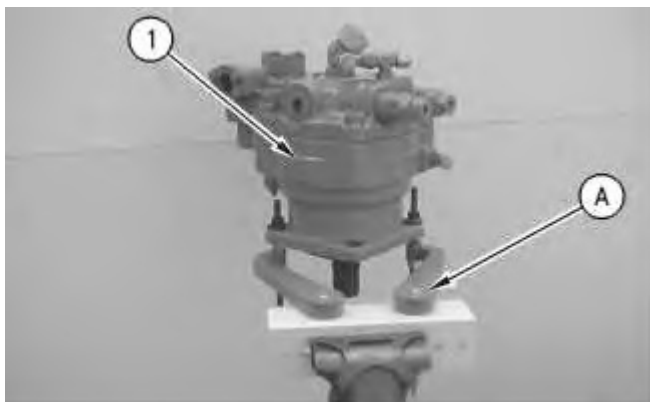

Illustration 22

g00877535

**<https://www.ebooklibonline.com>**

Hello dear friend!

Thank you very much for reading.

Enter the link into your browser.

The full manual is available for immediate download.

**<https://www.ebooklibonline.com>**