



Service Repair Manual

Model

432D BACKHOE LOADER

[Previous Screen](#)

Product: BACKHOE LOADER

Model: 432D BACKHOE LOADER BLD

Configuration: 432D Backhoe Loader BLD01595-03844 (MACHINE) POWERED BY 3054 Engine

Disassembly and Assembly

416D, 420D, 424D, 428D, 430D, 432D, 438D and 442D Backhoe Loaders Power Train

Media Number -REN3578-12

Publication Date -01/04/2010

Date Updated -13/04/2010

i01504174

Solenoid Valve (Transmission) - Install

SMCS - 5479-012-T3

Installation Procedure for Direct Drive Solenoid Valve



Personal injury can result from hydraulic oil pressure and hot oil.

Hydraulic oil pressure can remain in the hydraulic system after the engine has been stopped. Serious injury can be caused if this pressure is not released before any service is done on the hydraulic system.

Make sure all of the attachments have been lowered, oil is cool before removing any components or lines. Remove the oil filler cap only when the engine is stopped, and the filler cap is cool enough to touch with your bare hand.

NOTICE

Care must be taken to ensure that fluids are contained during performance of inspection, maintenance, testing, adjusting and repair of the product. Be prepared to collect the fluid with suitable containers before opening any compartment or disassembling any component containing fluids.

Refer to Special Publication, NENG2500, "Caterpillar Tools and Shop Products Guide" for tools and supplies suitable to collect and contain fluids on Caterpillar products.

Dispose of all fluids according to local regulations and mandates.

Note: The transmission has been removed for photographic purposes.



Illustration 1

g00780356

1. Check the four O-rings (5) for wear. Replace the O-rings if the O-rings are in poor condition.
2. Install four caps (3) and bolts under each cap.

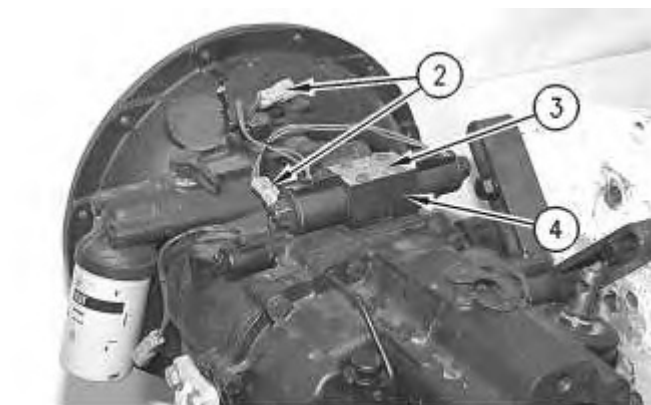

Illustration 2

g00780353

3. Connect wiring harness (2) .
4. Install the transmission solenoid valve (4) .

<https://www.ebooklibonline.com>

Hello dear friend!

Thank you very much for reading.

Enter the link into your browser.

The full manual is available for immediate download.

<https://www.ebooklibonline.com>

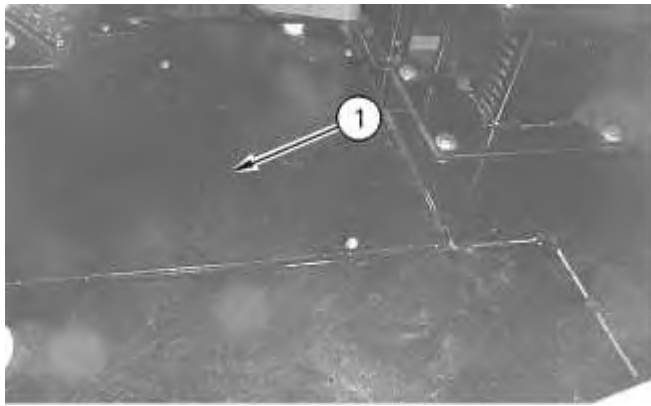

Illustration 3

g00780351

5. Install the floorplate (1) .

[Copyright 1993 - 2019 Caterpillar Inc.](#)

[All Rights Reserved.](#)

[Private Network For SIS Licensees.](#)

Wed Sep 18 14:54:36 UTC+0800 2019

[Previous Screen](#)

Product: BACKHOE LOADER

Model: 432D BACKHOE LOADER BLD

Configuration: 432D Backhoe Loader BLD01595-03844 (MACHINE) POWERED BY 3054 Engine

Disassembly and Assembly

416D, 420D, 424D, 428D, 430D, 432D, 438D and 442D Backhoe Loaders Power Train

Media Number -REN3578-12

Publication Date -01/04/2010

Date Updated -13/04/2010

i01504185

Solenoid Valve (Transmission) - Install

SMCS - 5479-012-T3

Installation Procedure for Powershift Transmission Arrangement



Personal injury can result from hydraulic oil pressure and hot oil.

Hydraulic oil pressure can remain in the hydraulic system after the engine has been stopped. Serious injury can be caused if this pressure is not released before any service is done on the hydraulic system.

Make sure all of the attachments have been lowered, oil is cool before removing any components or lines. Remove the oil filler cap only when the engine is stopped, and the filler cap is cool enough to touch with your bare hand.

NOTICE

Care must be taken to ensure that fluids are contained during performance of inspection, maintenance, testing, adjusting and repair of the product. Be prepared to collect the fluid with suitable containers before opening any compartment or disassembling any component containing fluids.

Refer to Special Publication, NENG2500, "Caterpillar Tools and Shop Products Guide" for tools and supplies suitable to collect and contain fluids on Caterpillar products.

Dispose of all fluids according to local regulations and mandates.

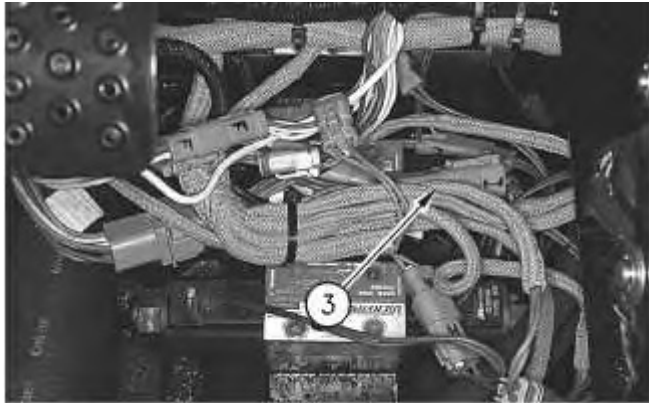

Illustration 1

g00780371

1. Connect all the wire harnesses on the three solenoid valves. Install four plugs and bolts (3) from each of the control valves (4). Install the three solenoid valves.

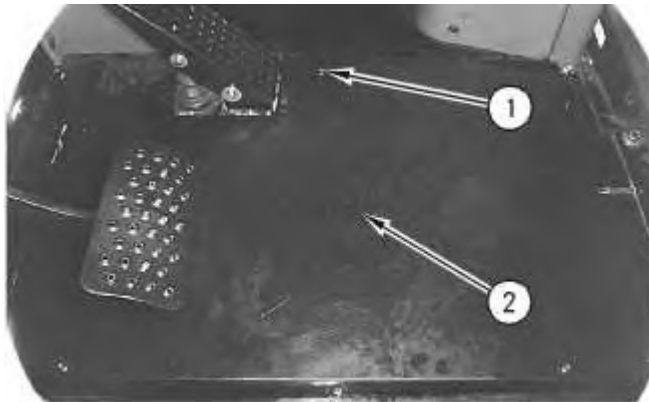

Illustration 2

g00780369

2. Install four bolts (1) and floorplate (2) .

[Previous Screen](#)

Product: BACKHOE LOADER

Model: 432D BACKHOE LOADER BLD

Configuration: 432D Backhoe Loader BLD01595-03844 (MACHINE) POWERED BY 3054 Engine

Disassembly and Assembly

416D, 420D, 424D, 428D, 430D, 432D, 438D and 442D Backhoe Loaders Power Train

Media Number -REN3578-12

Publication Date -01/04/2010

Date Updated -13/04/2010

i01457233

Transmission (Direct Drive) - Remove

SMCS - 3030-011-DD

Removal Procedure

Table 1

Required Tools			
Tool	Part Number	Part Description	Qty
A	8S-7640	Stand	2
	8S-7611	Tube	2
	8S-7615	Pin	2
B	1U-9760	Jack Stand	2
C	1U-7505	Transmission Jack	1
D	1U-7558	Mounting Brackets	2
E	FT-2535	Engine Support Bar Assembly	1

Start By:

- A. Remove the front drive shaft. Refer to Disassembly and Assembly, "Drive Shaft (Front) - Remove and Install".
- B. Remove the rear drive shaft. Refer to Disassembly and Assembly, "Drive Shaft (Rear) - Remove and Install".
- C. Remove the piston pump. Refer to Disassembly and Assembly, RENR3585, "Piston Pump (Implement and Steering) - Remove".
 1. Use a suitable lifting device in order to raise the machine to a height of 91.4 mm (36 inch) between the ground and the side step.

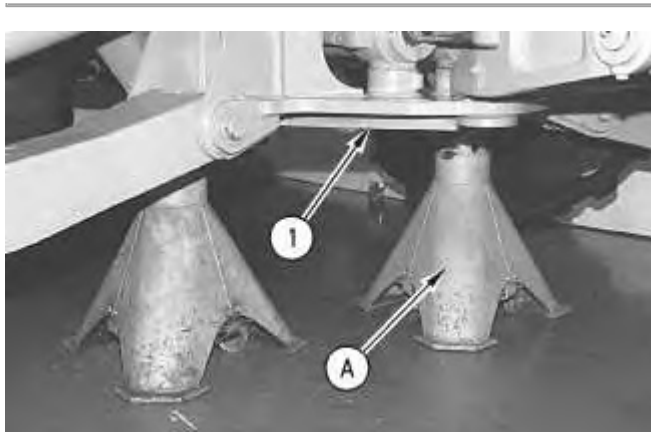

Illustration 1

g00760888

2. Place tooling (A) under rear frame (1) .

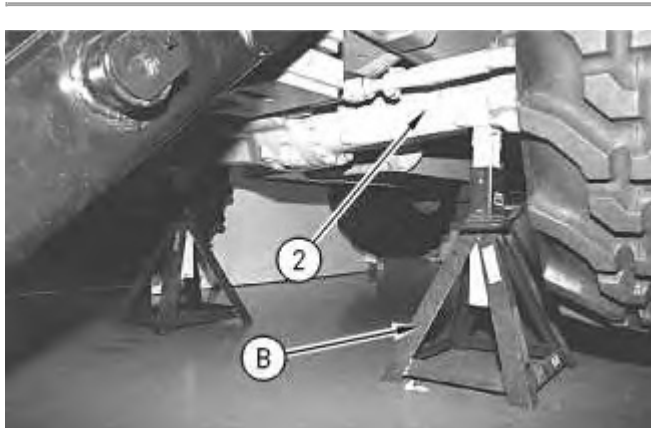

Illustration 2

g00760890

3. Place tooling (B) under front axle (2) .



4. Remove inspection plate (3). Install tooling (E) in order to support the engine.



Illustration 4

g00762357

5. Remove plug (4) and drain the transmission oil into a suitable container. The capacity of the transmission is 18.5 L (4.9 US gal).

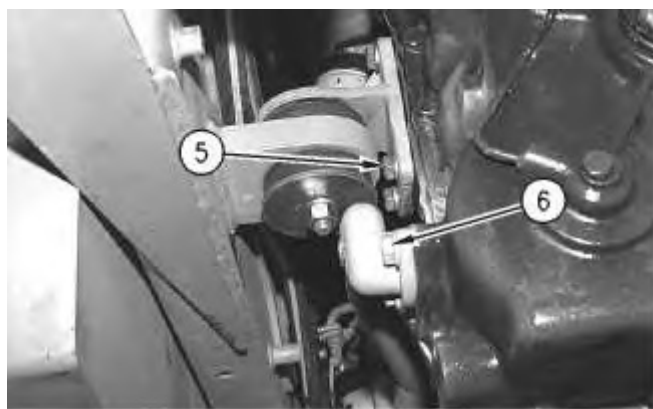

Illustration 5

g00762358

6. Remove four bolts (5) .
 7. Repeat Step 6 for the opposite side.
 8. Remove two bolts (6) .
-

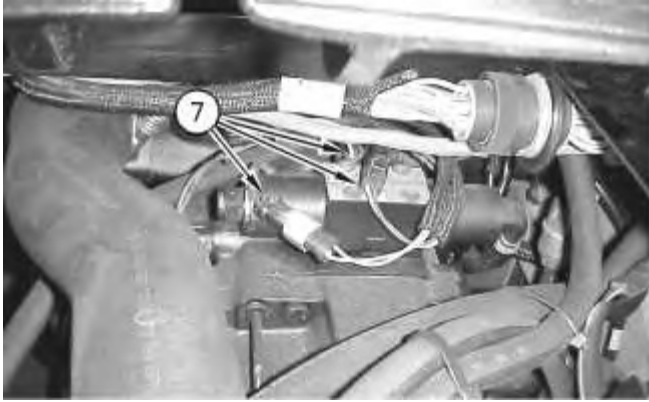

Illustration 6

g00762561

9. Disconnect three electrical connectors (7) .

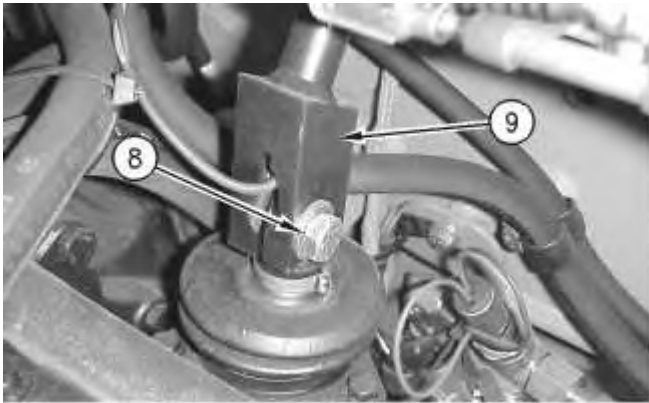

Illustration 7

g00762562

10. Loosen bolt (8) and slide rod assembly (9) off the transmission lever.

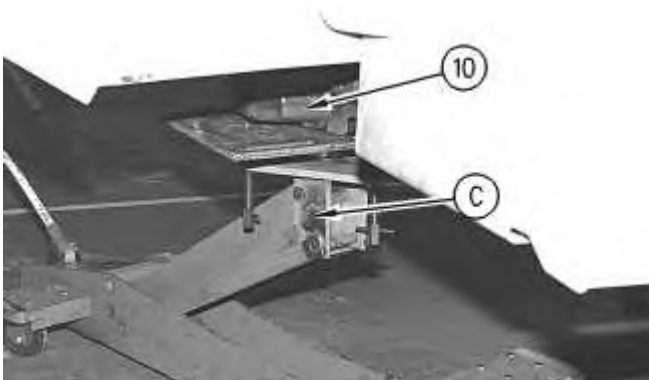

Illustration 8

g00762359

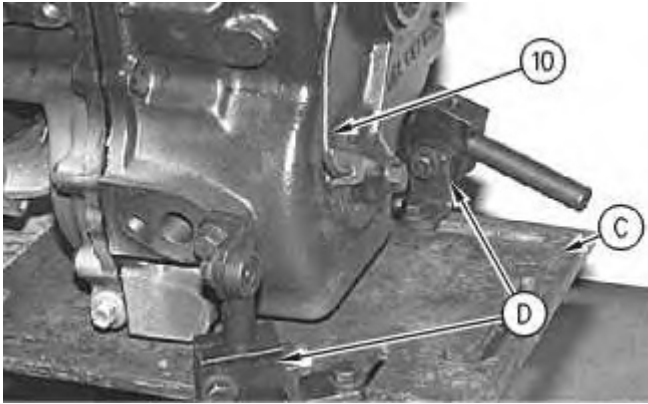

Illustration 9

g00762473

11. Support transmission (10) with tooling (C), as shown.
12. Attach tooling (D) to tooling (C) and transmission (10) in order to maintain a good balance.

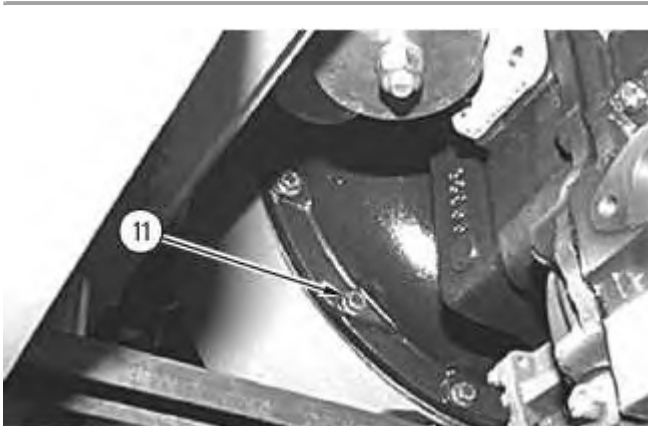

Illustration 10

g00762479

13. Remove fourteen bolts (11) .
14. Carefully move transmission (10) away from the engine in order to clear the torque converter. Lower transmission (10) to the ground. The weight of transmission (10) is 185 kg (408 lb).

[Previous Screen](#)

Product: BACKHOE LOADER

Model: 432D BACKHOE LOADER BLD

Configuration: 432D Backhoe Loader BLD01595-03844 (MACHINE) POWERED BY 3054 Engine

Disassembly and Assembly

416D, 420D, 424D, 428D, 430D, 432D, 438D and 442D Backhoe Loaders Power Train

Media Number -REN3578-12

Publication Date -01/04/2010

Date Updated -13/04/2010

i01380368

Transmission (Direct Drive) - Disassemble

SMCS - 3030-015-DD; 3066-015

Disassembly Procedure

Table 1

Required Tools			
Tool	Part Number	Part Description	Qty
A	1U-5750	Engine Stand	1
B	6V-2157	Link Bracket	1
C	9S-9152	Puller Assembly	1
C	5F-7465	Puller	1
C		3/8inch x 6inch Bolt	2
D	4C-3652	Spring Compressor	1
E	1U-6405	Puller	1
F	4C-3802	Puller	1
G	8H-0663	Puller	1
G	5F-7465	Puller	1
H	8B-7551	Puller	1
H	6V-3010	Puller	1
I	137-8102	Spring Compressor	1
J	4C-3089	Puller	1

Start By:

- A. Remove the transmission. Refer to Disassembly and Assembly, "Transmission (Direct Drive) - Remove".

NOTICE

Care must be taken to ensure that fluids are contained during performance of inspection, maintenance, testing, adjusting and repair of the product. Be prepared to collect the fluid with suitable containers before opening any compartment or disassembling any component containing fluids.

Refer to Special Publication, NENG2500, "Caterpillar Tools and Shop Products Guide" for tools and supplies suitable to collect and contain fluids on Caterpillar products.

Dispose of all fluids according to local regulations and mandates.

Note: Cleanliness is an important factor. Before the disassembly procedure, the exterior of the component should be thoroughly cleaned. This will help to prevent dirt from entering the internal mechanism.

Note: The transmission will be disassembled in major components. The major components will then be disassembled.

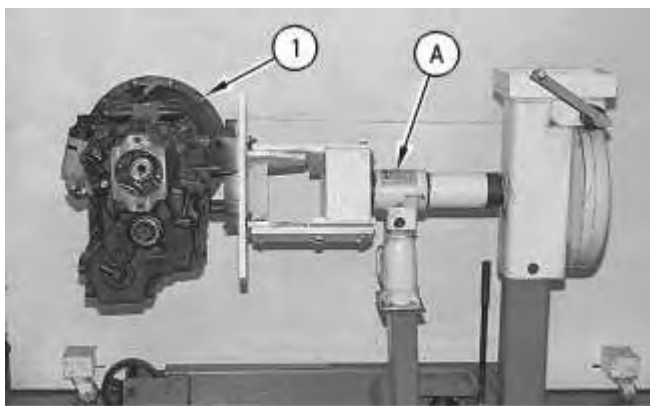

Illustration 1

g00728888

1. Install transmission (1) on tooling (A).
-

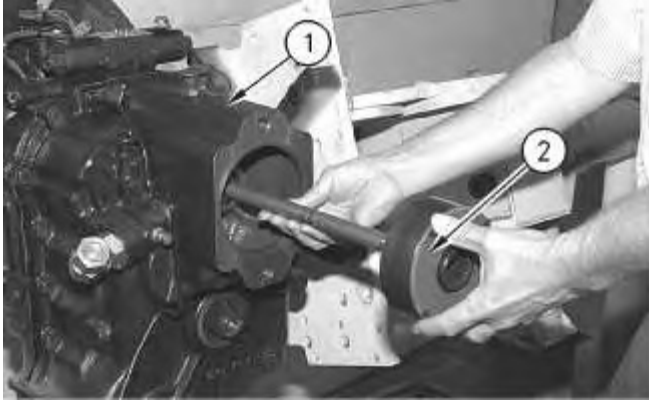

Illustration 2

g00728895

2. Remove Implement pump drive shaft (2) from transmission (1) .

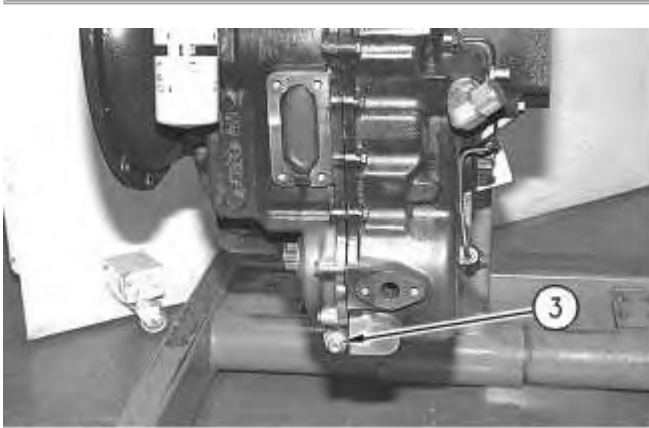

Illustration 3

g00728902

3. Remove plug (3). Drain the transmission oil into a suitable container. The capacity of the transmission is 11.3 L (3 US gal).

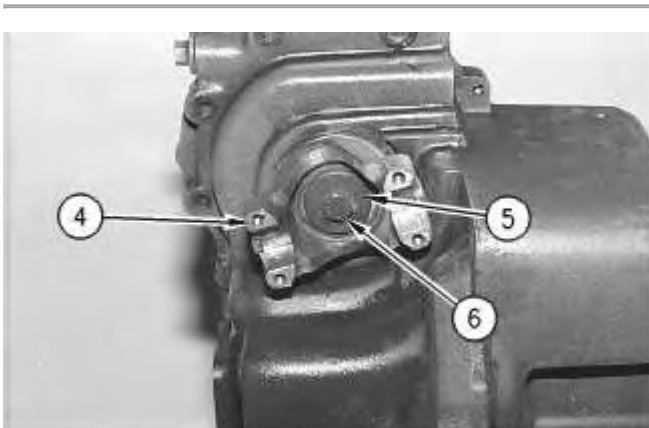

Illustration 4

g00728906

4. Remove bolt (6), washer (5), and yoke (4) .

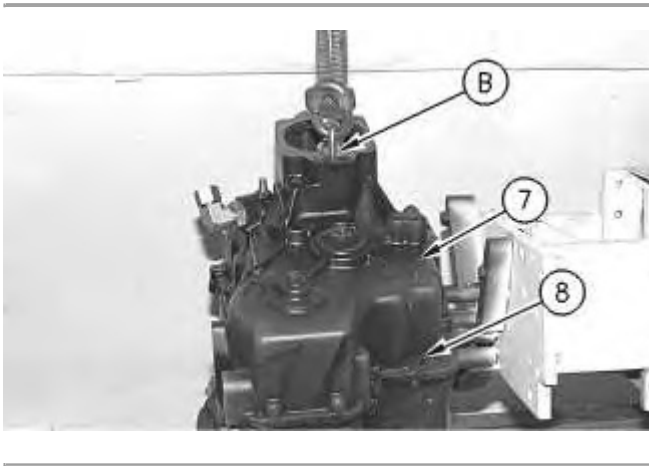

Illustration 5

g00728913

5. Attach tooling (B) to case (7). Attach a suitable lifting device to tooling (B). Remove fourteen bolts (8). Remove case (7) from the transmission. The weight of case (7) is 42 kg (94 lb).

(Direct Drive) Output Shaft (Front)



Illustration 6

g00728940

1. Remove front output shaft (9) .
-

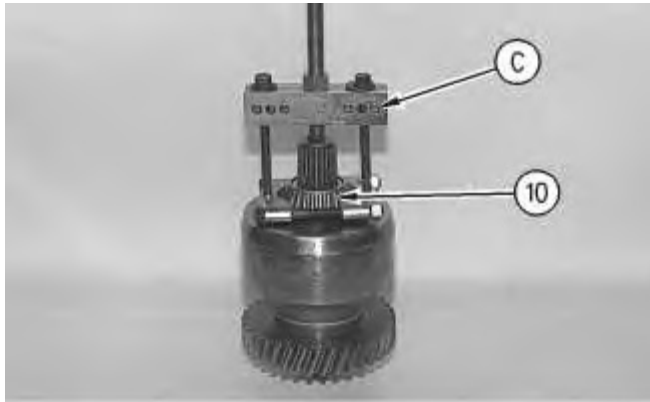

Illustration 7

g00728943

2. Use tooling (C) in order to remove bearing cone (10) .

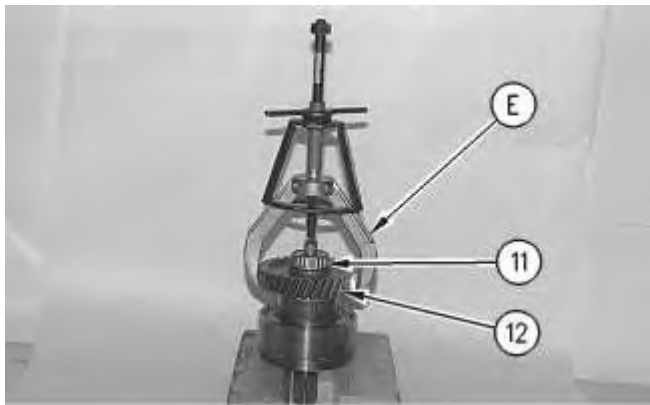

Illustration 8

g00728944

3. Use tooling (E) in order to remove bearing cone (11) and gear (12) .

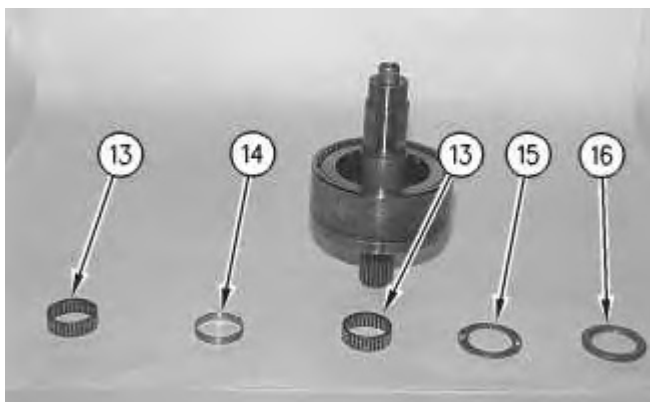

Illustration 9

g00728945

4. Remove two roller bearings (13), spacer (14), needle bearing (15), and thrust washer (16) .

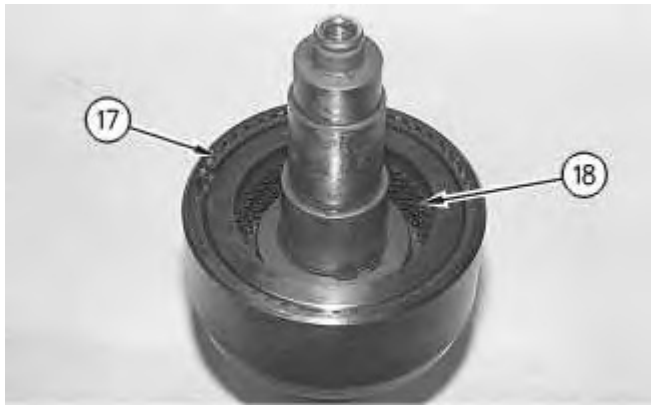

Illustration 10

g00728948

5. Remove retainer (17) and clutch pack (18) .

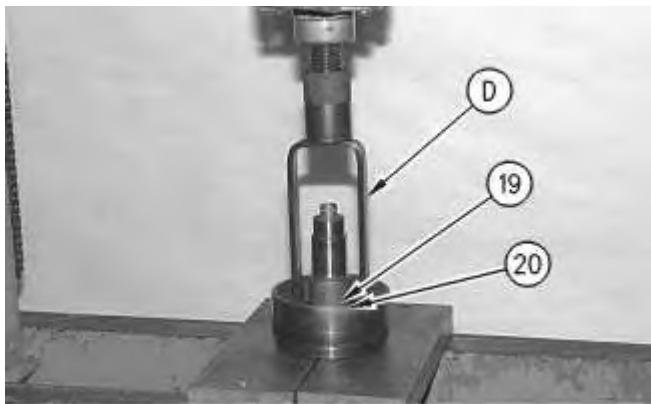
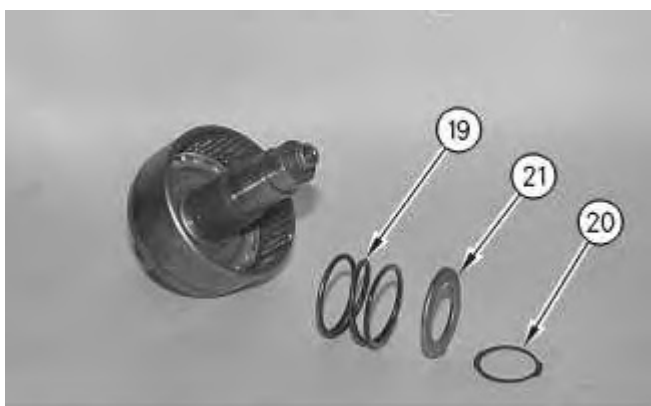

Illustration 11

g00728950

6. Use a suitable press and tooling (D) in order to compress spring (19). Use tooling (K) in order to remove snap ring (20) .



7. Remove snap ring (20), retainer (21), and spring (19) .



Illustration 13

8. Release piston (22) by blowing shop air into the lube passage, as shown.



Illustration 14

9. Use a seal pick in order to remove the seals from piston (22) .

(Direct Drive) Output Shaft (Rear)

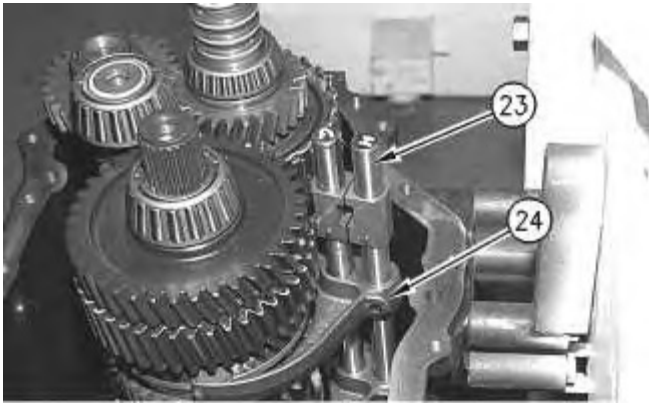

Illustration 15

g00729062

1. Remove screws (24) from each of the gearshift rods (23) .

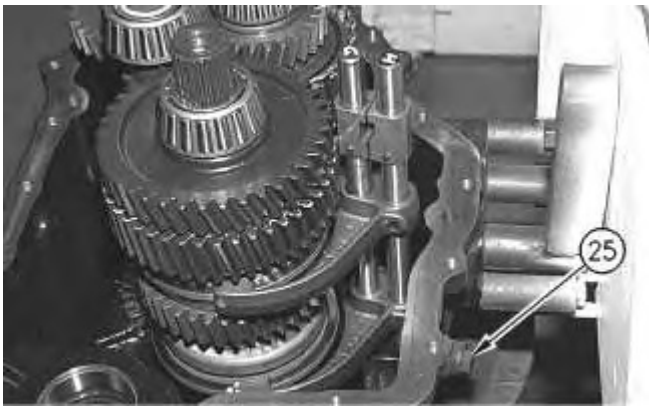

Illustration 16

g00729064

2. Remove plug (25) .

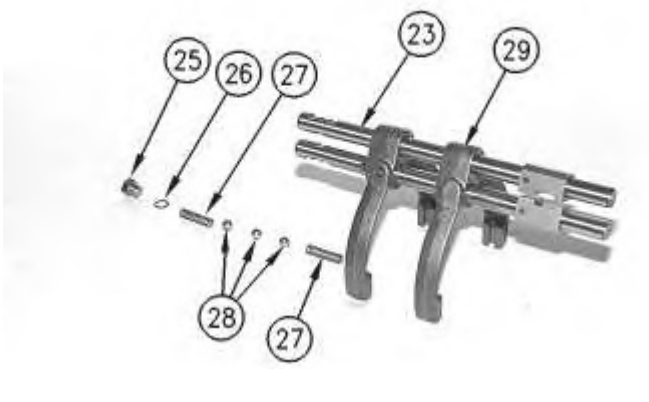

Illustration 17

g00729196

3. Remove plug (25), O-ring (26), two springs (27), and three balls (28). Remove two gearshift rods (23) from shift forks (29) .

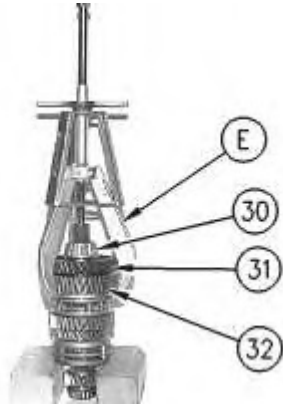

Illustration 18

g00729197

4. Use tooling (E) in order to remove bearing (30), gear (31), and gear (32) .



Illustration 19

g00729198

5. Remove bearings (33), spacer (34), and synchronizer (35) .
-

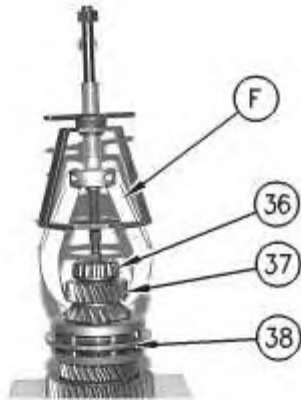

Illustration 20

g00729199

6. Use tooling (F) in order to remove bearing (36) and gear (37). Remove synchronizer (38) .

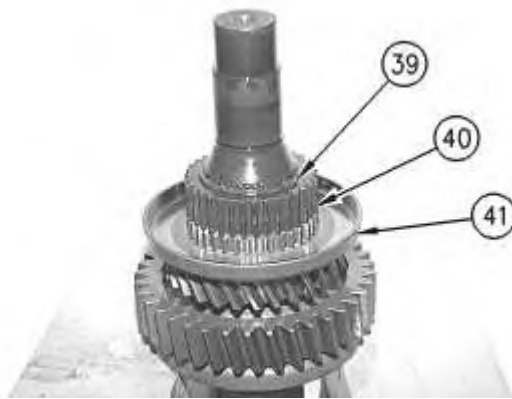

Illustration 21

g00729200

7. Use tooling (K) in order to remove snap ring (39). Remove gear (40) and housing (41) .

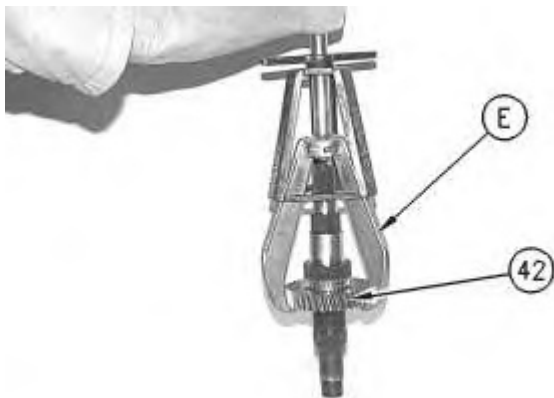

Illustration 22

g00729201

8. Use tooling (E) in order to remove gear (42) .

(Direct Drive) Shaft

1. Remove the shaft by hand for disassembly.

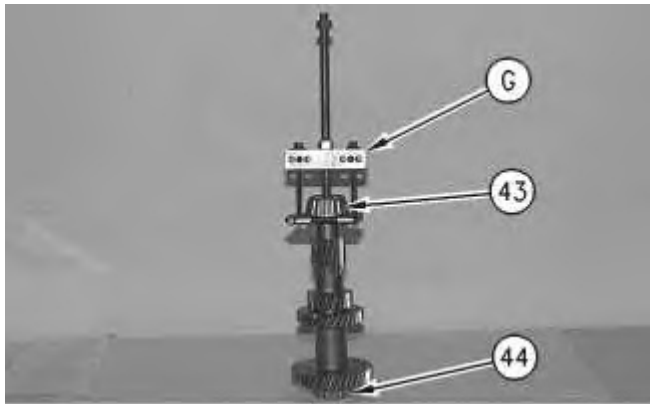

Illustration 23

g00729202

2. Use tooling (G) in order to remove bearings (43) and (44) .

(Direct Drive) Reverse Shaft

1. Remove the reverse shaft by hand for disassembly.

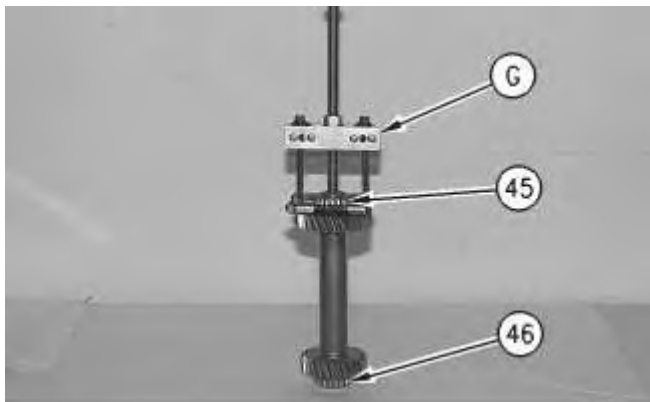

Illustration 24

g00729204

2. Use tooling (G) in order to remove bearings (45) and (46) .

(Direct Drive) Input Shaft

1. Remove the input shaft by hand for disassembly.
-

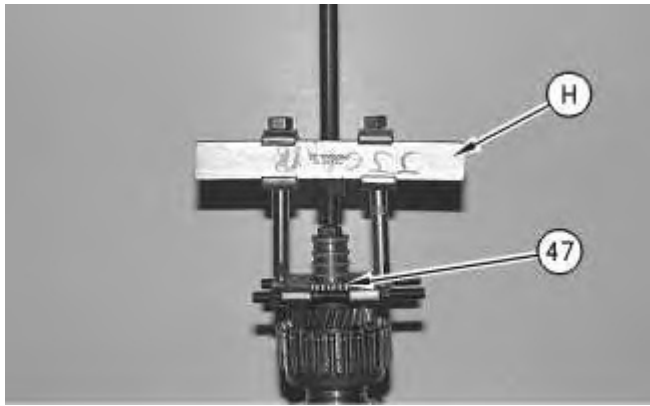

Illustration 25

g00729207

2. Use tooling (H) in order to remove bearing (47) .

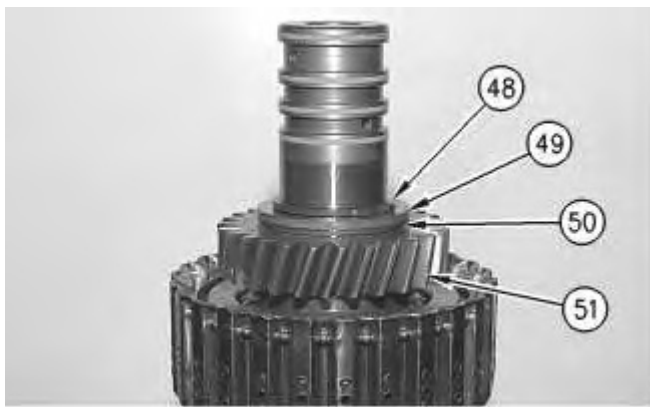

Illustration 26

g00729208

3. Use tooling (K) in order to remove snap ring (48). Remove spacer (49), needle bearing (50), and gear (51) .

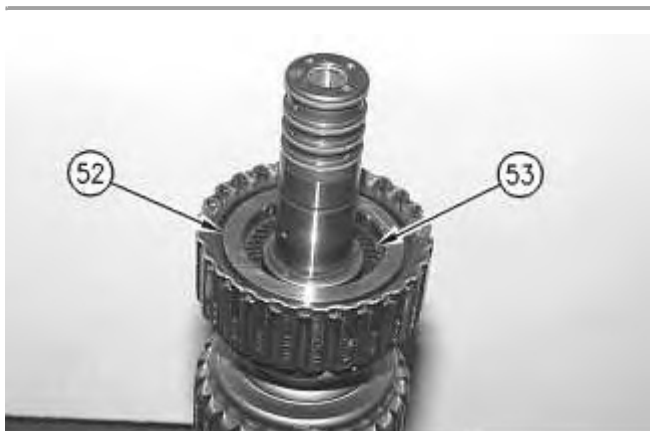

Illustration 27

g00729210

4. Remove retainer (52) and clutch pack (53) .

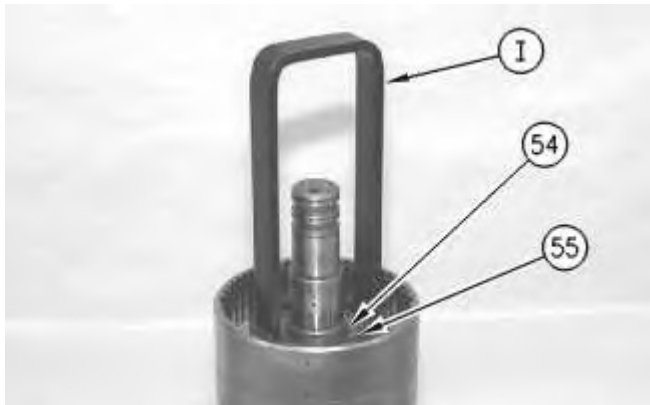

Illustration 28

g00729213

5. Use tooling (I) and a suitable press in order to compress spring (55). Use tooling (K) in order to remove snap ring (54). Remove the retainer and spring (55) .

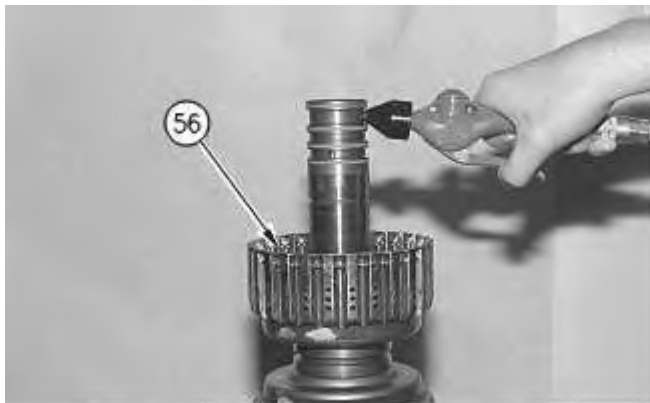

Illustration 29

g00729257

6. Release piston (56) by blowing shop air into the lube passage, as shown.
-

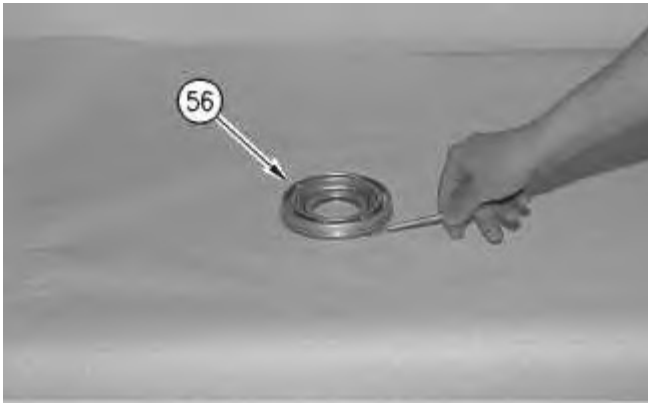

Illustration 30

g00729258

7. Use a seal pick in order to remove the seals from piston (56) .

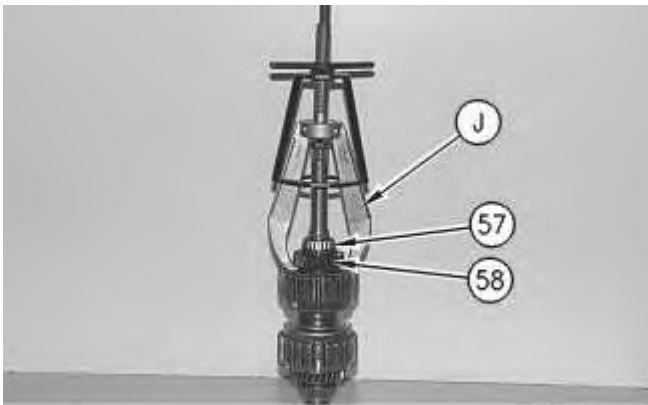

Illustration 31

g00729260

8. Use tooling (J) in order to remove bearing (57) and gear (58) .

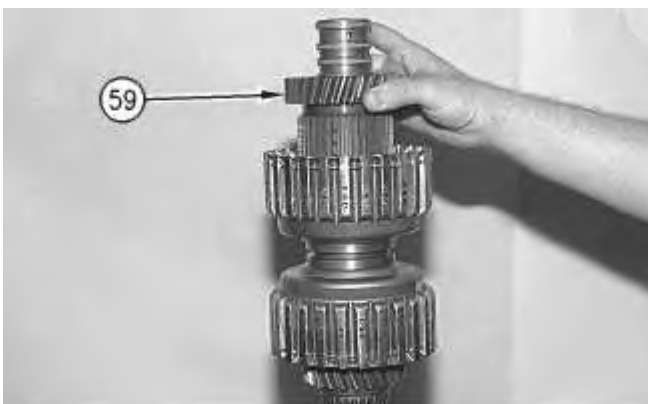

Illustration 32

g00729261

9. Remove gear (59) from the clutch pack.

10. Repeat Steps 4 through 7 for the remainder of the input shaft.

Transmission Case

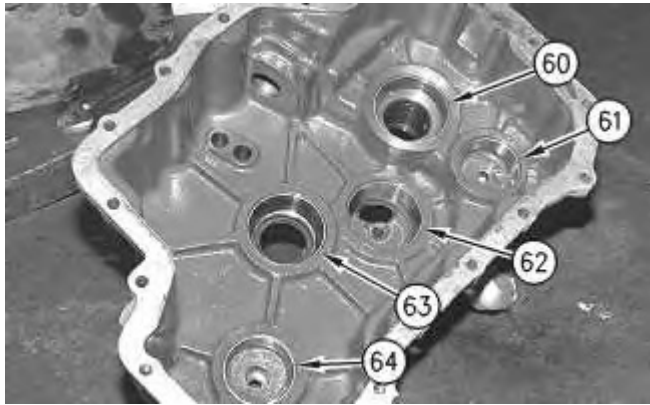

Illustration 33

g00729262

Note: Record the measurement and placement of the shims behind the bearing cups in order to aid in assembly.

1. Remove bearing cups (60), (61), (62), (63), and (64) .

[Previous Screen](#)

Product: BACKHOE LOADER

Model: 432D BACKHOE LOADER BLD

Configuration: 432D Backhoe Loader BLD01595-03844 (MACHINE) POWERED BY 3054 Engine

Disassembly and Assembly

416D, 420D, 424D, 428D, 430D, 432D, 438D and 442D Backhoe Loaders Power Train

Media Number -REN3578-12

Publication Date -01/04/2010

Date Updated -13/04/2010

i01381641

Transmission (Direct Drive) - Assemble

SMCS - 3030-016-DD; 3066-016

Assembly Procedure

Table 1

Required Tools			
Tool	Part Number	Part Description	Qty
A	137-8102	Spring Compressor	1
B	1P-1859	Snap Ring Pliers	1
C	4C-3652	Spring Compressor	1
D	6V-2157	Link Bracket	1
E	8T-5096	Indicator	1
F	1U-5750	Engine Stand	1

Note: The transmission will be assembled in major components. The major components will then be assembled.

Note: Cleanliness is an important factor. Before assembly, all parts should be thoroughly cleaned in cleaning fluid. Allow the parts to air dry. Wiping cloths or rags should not be used to dry parts. Lint may be deposited on the parts which may cause later trouble. Inspect all parts. If any parts are worn or damaged, use new parts for replacement.

Note: Apply a light film of clean transmission oil to all components before assembly.

Transmission case

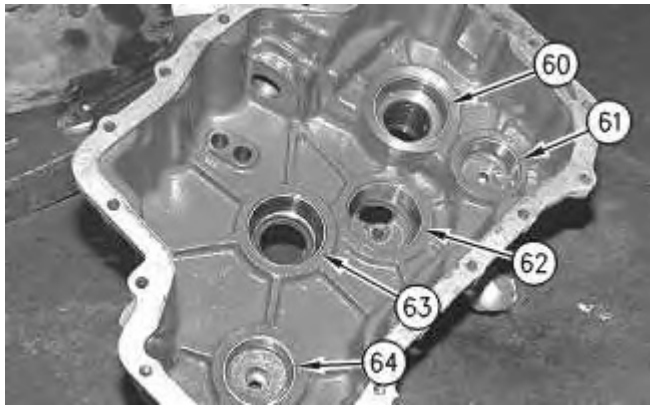

Illustration 1

g00729262

Note: Install the shims behind each bearing cup that was recorded on the disassembly procedure.

1. Install bearing cups (60), (61), (62), (63), and (64) .

(Direct Drive) Input Shaft

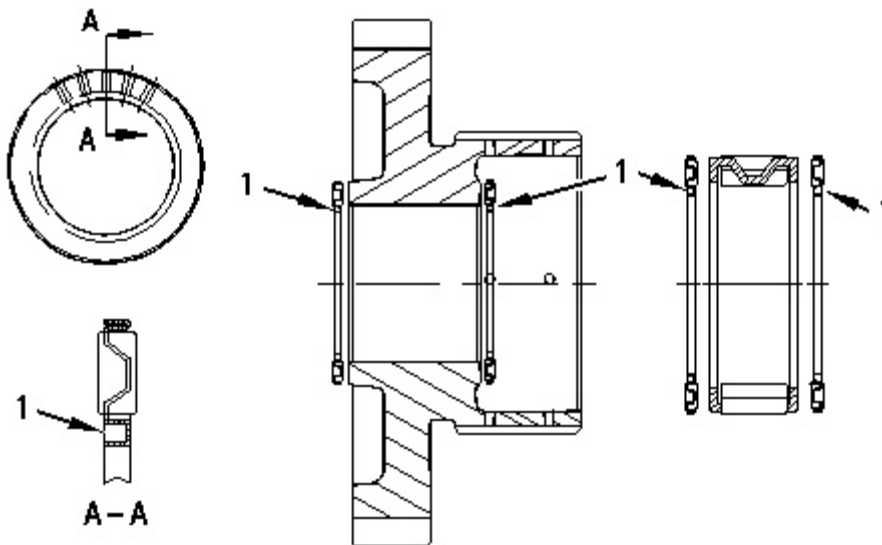

Illustration 2

g00731364

1. Install the needle thrust bearings on the shafts. The open end of cups (1) must point away from the bearings or gears that are contacted.
-

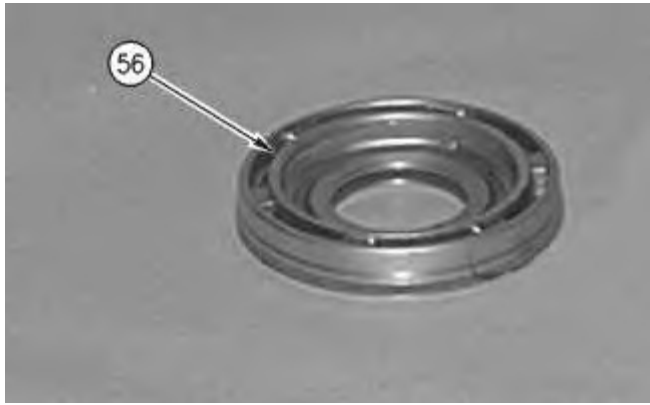

Illustration 3

g00729745

2. Install the seals on piston (56) .

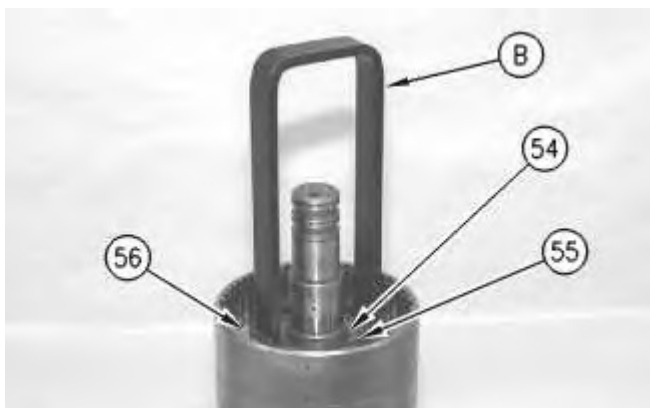

Illustration 4

g00729752

3. Install piston (56). Install the retainer and spring (55). Use tooling (A) and a suitable press in order to compress spring (55). Use tooling (B) in order to install snap ring (54) .

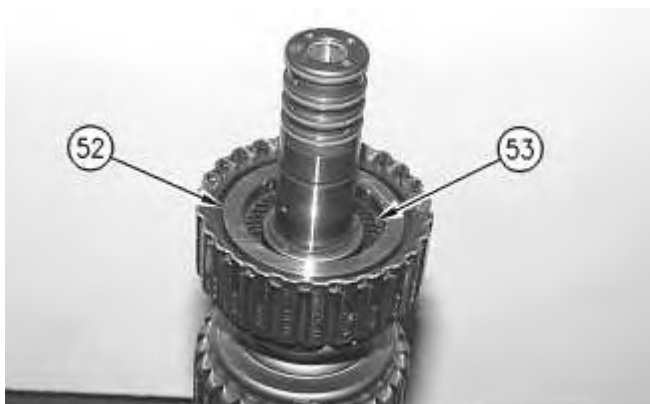

Illustration 5

g00729210



Suggest:

If the above button click is invalid.

Please download this document

first, and then click the above link

to download the complete manual.

Thank you so much for reading

4. Install clutch pack (53) and retainer (52) .
5. Repeat Steps 2 through 4 for the opposite end of the input shaft.

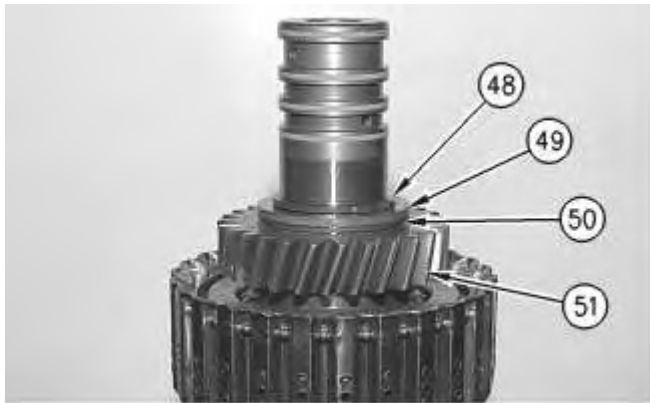

Illustration 6

g00729208

6. Install gear (51), needle bearing (50), and spacer (49). Use tooling (B) in order to install snap ring (48) .

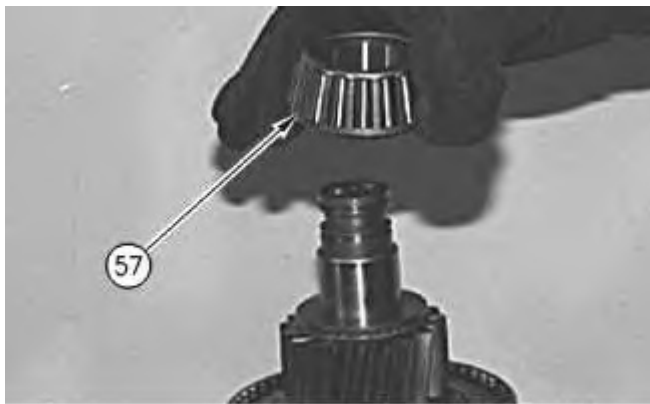

Illustration 7

g00729771

7. Heat bearing cone (57) to 135 °C (275 °F). Install bearing cone (57) .
8. Install the input shaft.

(Direct Drive) Reverse Shaft

<https://www.ebooklibonline.com>

Hello dear friend!

Thank you very much for reading.

Enter the link into your browser.

The full manual is available for immediate download.

<https://www.ebooklibonline.com>