



Service Repair Manual

Model

320C and 320C L 320CL Excavator

[Previous Screen](#)

Product: EXCAVATOR

Model: 320C EXCAVATOR RAW

Configuration: 320C & 320C L Excavators RAW00001-UP (MACHINE) POWERED BY 3066 Engine

Disassembly and Assembly 3064 and 3066 Engines for Caterpillar Built Machines

Media Number -SEN5553-10

Publication Date -01/05/2012

Date Updated -15/05/2012

i01567260

Flywheel - Install

SMCS - 1156-012

Installation Procedure

Table 1

Required Tools			
Tool	Part Number	Part Description	Qty
A	138-7575	Link Bracket	1

NOTICE

Keep all parts clean from contaminants.

Contaminants may cause rapid wear and shortened component life.

WARNING

Always wear protective gloves when handling parts that have been heated.

1. Perform the following procedure, if the ring gear was removed from the flywheel:
 - a. Heat the ring gear to 150 °C (302 °F) in an oven.

- b. Press the ring gear onto the flywheel.

Note: Prior to the installation of the flywheel, refer to Specifications, "Flywheel" for information on checking the flywheel assembly for flatness.

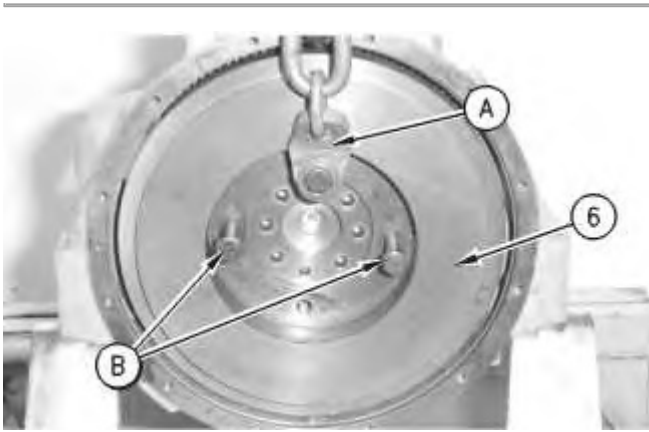

Illustration 1

g00605504

2. Install Tool (A), a strap, and a suitable lifting device onto flywheel (6) .
3. Install flywheel (6). The weight of the flywheel is 50 kg (110 lb).



Illustration 2

g00605501

4. Install six bolts (5) in order to secure flywheel (6) onto the crankshaft. Tighten the bolts to a torque of 83 ± 5 N·m (61 ± 4 lb ft).
 5. Remove Tool (A) from the flywheel.
-

<https://www.ebooklibonline.com>

Hello dear friend!

Thank you very much for reading.

Enter the link into your browser.

The full manual is available for immediate download.

<https://www.ebooklibonline.com>

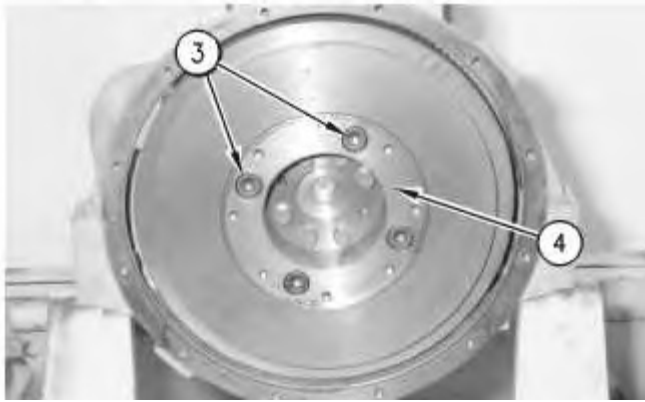

Illustration 3

g00605497

6. Place the inner ring (4) in position on the flywheel.
7. Install four socket head bolts (3) in order to secure the inner ring (4) to the flywheel.

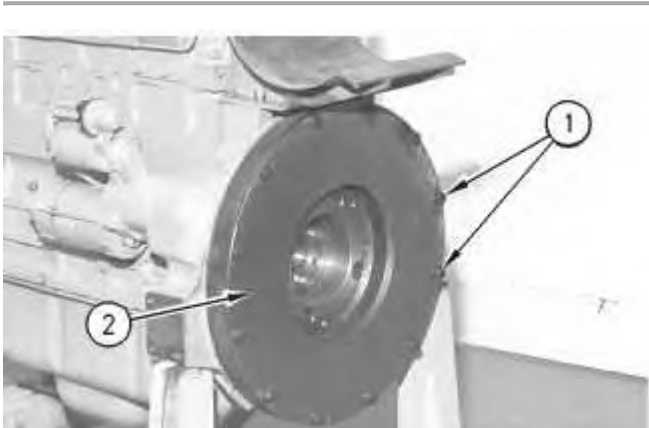

Illustration 4

g00605492

8. Place the adapter (2) in position on the flywheel housing.
9. Install twelve bolts and washers (1) in order to secure the adapter (2) on the flywheel housing.
10. Check the flywheel runout. Refer to Testing and Adjusting, "Flywheel Housing - Inspect" for more information on flywheel runout.

Previous Screen

Product: EXCAVATOR

Model: 320C EXCAVATOR RAW

Configuration: 320C & 320C L Excavators RAW00001-UP (MACHINE) POWERED BY 3066 Engine

**Disassembly and Assembly
3064 and 3066 Engines for Caterpillar Built Machines**

Media Number -SEN5553-10

Publication Date -01/05/2012

Date Updated -15/05/2012

i01135944

Crankshaft Rear Seal - Remove

SMCS - 1161-011

Removal Procedure

Table 1

Required Tools			
Tool	Part Number	Part Description	Qty
A	1U-7600	Slide Hammer Puller	1
B	5P-7312	Seal Distorter	1
	5P-7338	Distorter Ring	2

Start By:

- a. Remove the flywheel. Refer to Disassembly and Assembly, "Flywheel - Remove".

NOTICE

Keep all parts clean from contaminants.

Contaminants may cause rapid wear and shortened component life.

NOTICE

Care must be taken to ensure that fluids are contained during performance of inspection, maintenance, testing, adjusting, and repair

of the product. Be prepared to collect the fluid with suitable containers before opening any compartment or disassembling any component containing fluids.

Refer to Special Publication, NENG2500, "Dealer Service Tool Catalog" for tools and supplies suitable to collect and contain fluids on Cat products.

Dispose of all fluids according to local regulations and mandates.

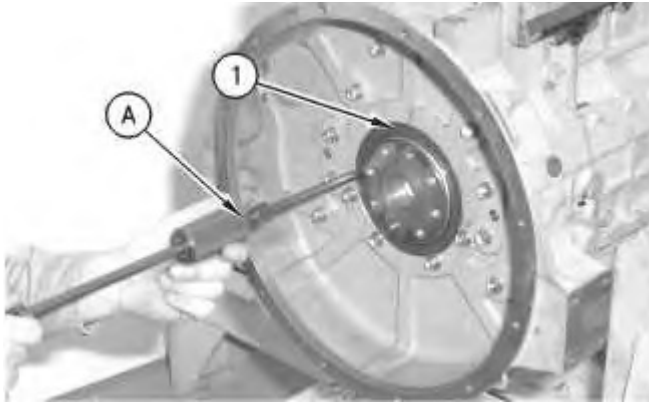

Illustration 1

g00604840

Note: If the oil seal shows a sign of oil leaks, remove the wear sleeve and the oil seal.

1. Drill three evenly spaced 3 mm (0.12 inch) holes in crankshaft rear seal (1).
2. Use Tool (A) to remove the crankshaft rear seal.

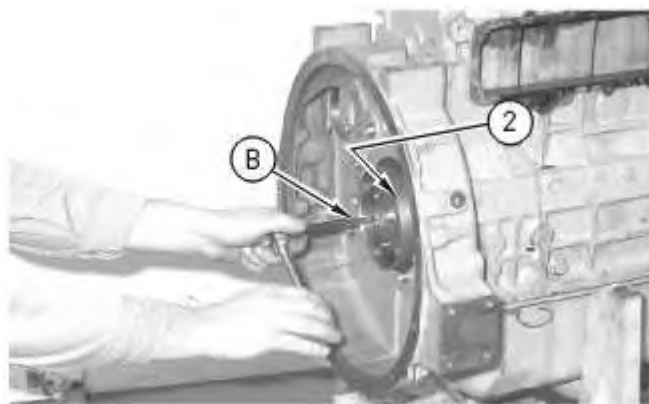

Illustration 2

g00604844

3. Use Tool (B) to remove the wear sleeve (2) (not shown) from the rear of the crankshaft.

Note: When you are removing the wear sleeve, take extreme care not to damage the crankshaft.

[Copyright 1993 - 2019 Caterpillar Inc.](#)

Sat Sep 28 15:04:58 UTC+0800 2019

[All Rights Reserved.](#)

[Private Network For SIS Licensees.](#)

[Previous Screen](#)

Product: EXCAVATOR

Model: 320C EXCAVATOR RAW

Configuration: 320C & 320C L Excavators RAW00001-UP (MACHINE) POWERED BY 3066 Engine

Disassembly and Assembly 3064 and 3066 Engines for Caterpillar Built Machines

Media Number -SEN5553-10

Publication Date -01/05/2012

Date Updated -15/05/2012

i01615317

Crankshaft Rear Seal - Install

SMCS - 1161-012

Installation Procedure

Table 1

Required Tools			
Tool	Part Number	Part Description	Qty
A	9U-6169	Installer	1
	9U-6171	Locator	1
	9U-6172	Bolt	2
	5P-8247	Hard Washer	1
	6V-3303	Bolt	1

NOTICE

Keep all parts clean from contaminants.

Contaminants may cause rapid wear and shortened component life.

- To install a new wear sleeve that is complete with a seal, use **169-5464** Quick Cure Primer to clean the outer diameter of the crankshaft and the inside diameter of the wear sleeve. Apply **4C-9507** Retaining Compound to the faces of all the mating parts.
-

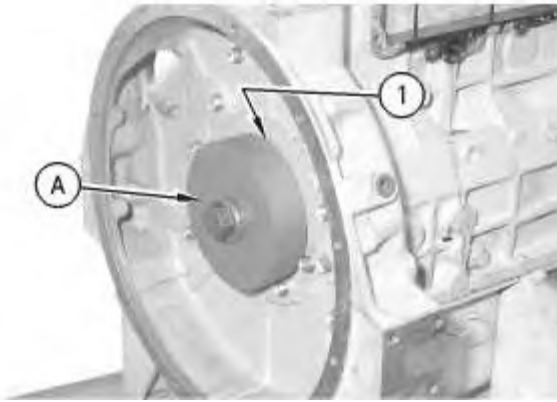

Illustration 1

g00604874

2. Install a new wear sleeve that is complete with a seal (1) (not shown) with Tool (A), as follows:

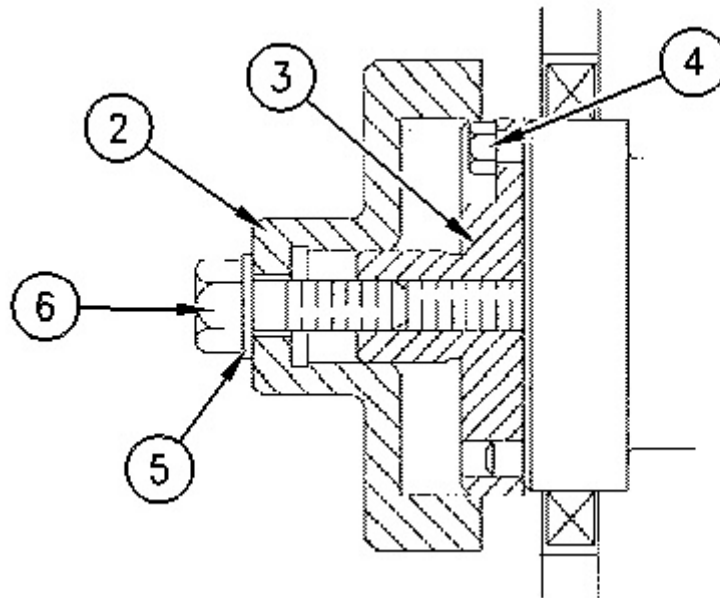

Illustration 2

g00604875

- a. Install **9U-6171** Locator (3) onto the crankshaft with **9U-6172** Bolt (4).
- b. Put the new wear sleeve that is complete with a seal in **9U-6169** Installer (2).
- c. Put **6V-3303** Bolt (6) through **5P-8247** Hard Washer (5) and **9U-6169** Installer (2) and thread into **9U-6171** Locator (3).
- d. Push the wear sleeve that is complete with a seal onto the crankshaft until **9U-6169** Installer (2) bottoms out.

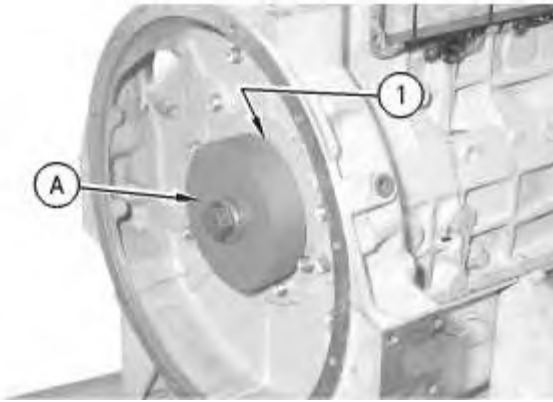

Illustration 3

g00604874

- e. Remove Tool (A) and check crankshaft rear seal (1) (not shown) for correct installation.

End By:

- a. Install the flywheel. Refer to Disassembly and Assembly, "Flywheel - Install".

Previous Screen

Product: EXCAVATOR

Model: 320C EXCAVATOR RAW

Configuration: 320C & 320C L Excavators RAW00001-UP (MACHINE) POWERED BY 3066 Engine

**Disassembly and Assembly
3064 and 3066 Engines for Caterpillar Built Machines**

Media Number -SEN5553-10

Publication Date -01/05/2012

Date Updated -15/05/2012

i05421135

Flywheel Housing - Remove and Install

SMCS - 1157-010

Removal Procedure

Table 1

Required Tools			
Tool	Part Number	Part Description	Qty
A	138-7575	Link Bracket	1
B	1P-0510	Driver Group	1

Start By:

- A. Remove the electric starting motor.
- B. Remove the flywheel and ring gear.

NOTICE

Keep all parts clean from contaminants.

Contaminants may cause rapid wear and shortened component life.

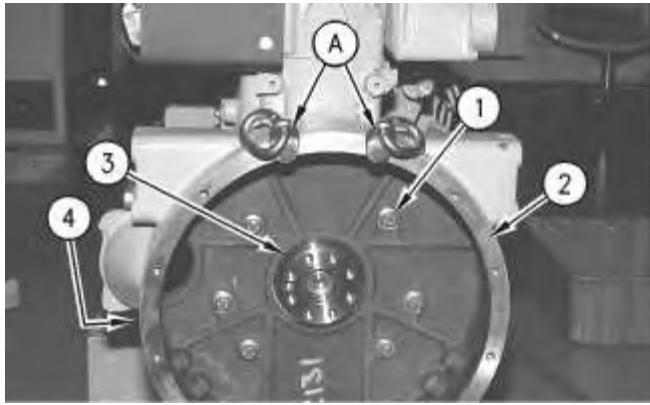

Illustration 1

g00605593

1. Install Tooling (A) , a strap, and a suitable lifting device onto flywheel housing (2) .
2. Remove bolts (1) and the washers that secure flywheel housing (2) to the cylinder block.
Note: Identify the four shorter bolts for later installation into the flywheel housing.
3. Remove flywheel housing (2) . The weight of the flywheel is approximately.29 kg (65 lb).
4. Check oil seal (3) for serviceability. If necessary, replace the oil seal and crankshaft wear sleeve.

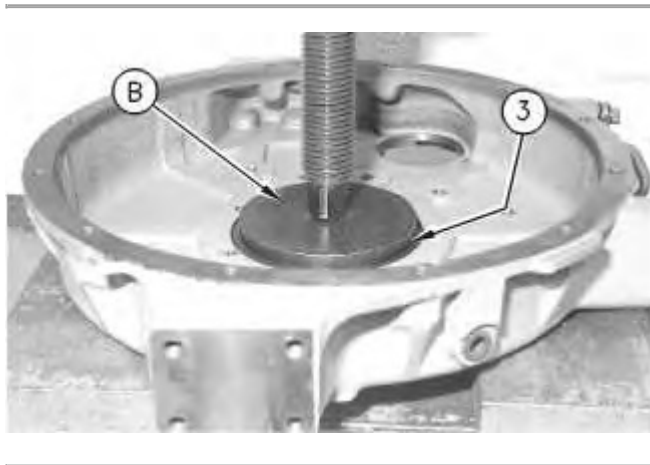

Illustration 2

g00605601

5. Use Tooling (B) in order to remove the oil seal (3) (not shown).

Installation Procedure

Table 2

Required Tools			
Tool	Part Number	Part Description	Qty
A	138-7575	Link Bracket	1

NOTICE

Keep all parts clean from contaminants.

Contaminants may cause rapid wear and shortened component life.

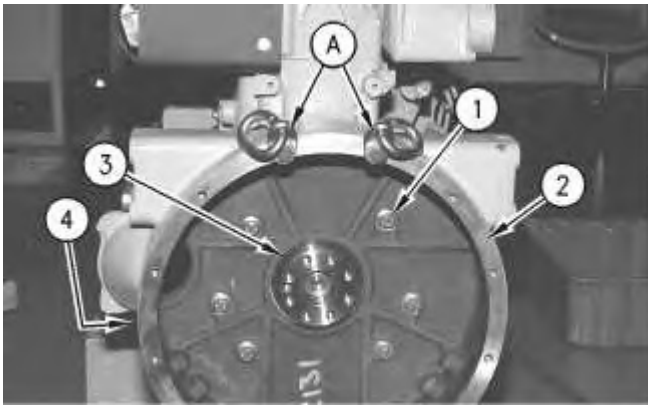

Illustration 3

g00605593

1. Clean old gasket material (4) from the mating surfaces of the cylinder block and the flywheel housing. Install a new gasket on the cylinder block.
2. Place flywheel housing (2) in position on the cylinder block.
3. Install the washers and bolts (1) in order to secure flywheel housing (2) to the cylinder block.
4. Use Tooling (B) in order to install the oil seal (3) , and the crankshaft wear sleeve (not shown).

End By:

- a. Install the flywheel.
- b. Install the electric starting motor.

[Previous Screen](#)

Product: EXCAVATOR

Model: 320C EXCAVATOR RAW

Configuration: 320C & 320C L Excavators RAW00001-UP (MACHINE) POWERED BY 3066 Engine

Disassembly and Assembly 3064 and 3066 Engines for Caterpillar Built Machines

Media Number -SEN5553-10

Publication Date -01/05/2012

Date Updated -15/05/2012

i01578488

Crankshaft Pulley - Remove and Install

SMCS - 1205-010

Removal Procedure

Table 1

Required Tools			
Tool	Part Number	Part Description	Qty
A	1P-2321	Combination Puller	1
B	6V-9120	Socket ⁽¹⁾	1

⁽¹⁾ Tool (B) is a 46 mm socket.

Start By:

- A. Remove the V-belts. Refer to Disassembly and Assembly, "V-Belts - Remove and Install".

NOTICE

Keep all parts clean from contaminants.

Contaminants may cause rapid wear and shortened component life.

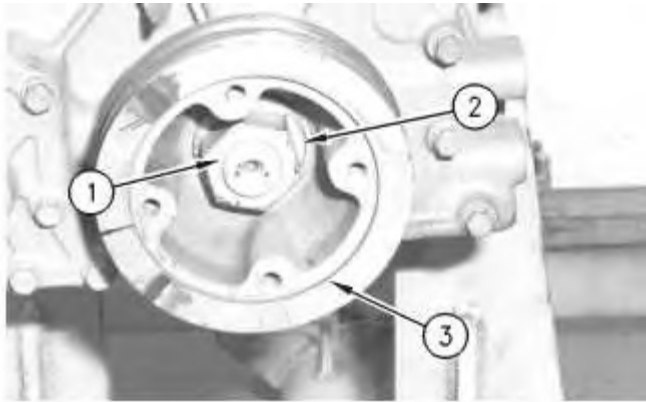

Illustration 1

g00604778

1. Use Tool (B) to remove nut (1) and washer (2) from the threaded end of the crankshaft.

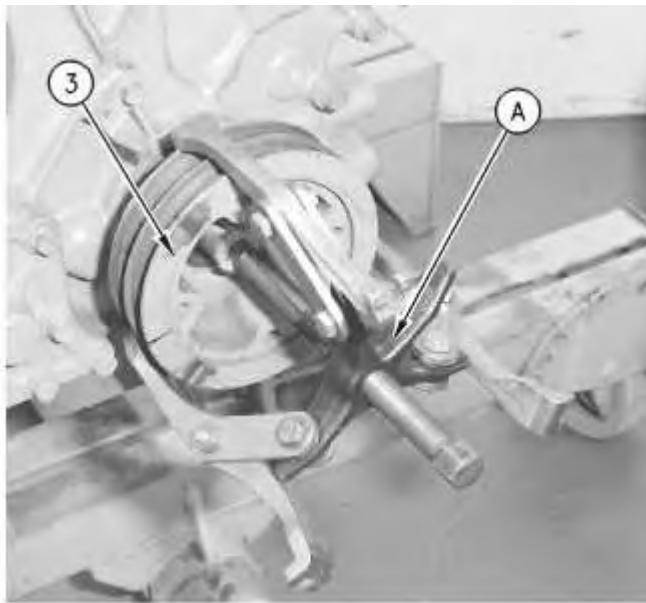

Illustration 2

g00604784

2. Use Tool (A) to remove crankshaft pulley (3) from the engine.
-

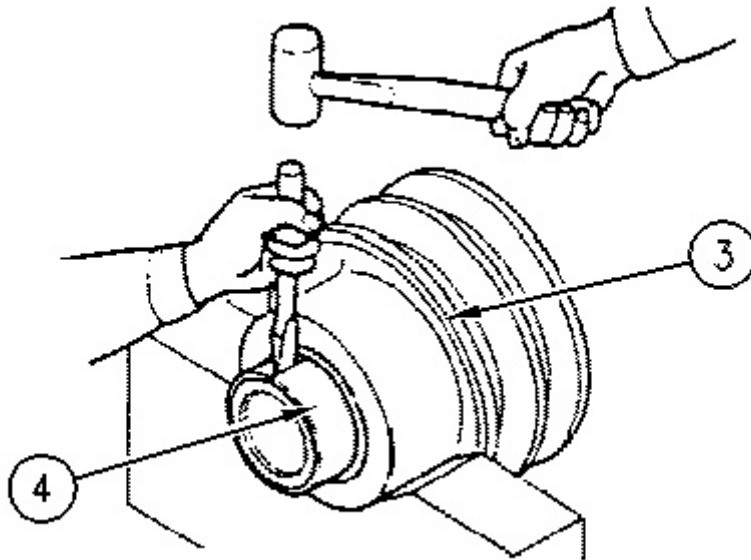

Illustration 3

g00604792

3. If it is necessary to remove the wear sleeve (4) from the crankshaft pulley (3), use a hammer and a chisel. Hold the chisel at right angles to the surface of the wear sleeve. Tap the wear sleeve in three places. You can remove the wear sleeve once the tension is released.

Installation Procedure

NOTICE

Keep all parts clean from contaminants.

Contaminants may cause rapid wear and shortened component life.

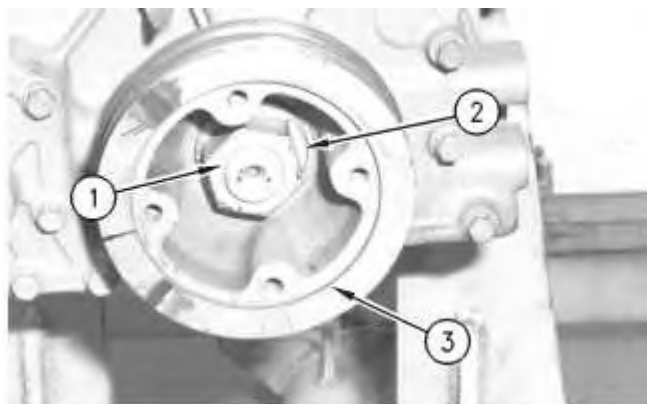

Illustration 4

g00604778

1. Put crankshaft pulley (3) in position on the engine.
2. Install washer (2) and nut (1). Use Tool (B) to tighten nut (1) to a torque of $490 \pm 10 \text{ N}\cdot\text{m}$ ($361 \pm 7 \text{ lb ft}$).

End By: Install the V-belts. Refer to Disassembly and Assembly, "V-Belts - Remove and Install".

Previous Screen

Product: EXCAVATOR

Model: 320C EXCAVATOR RAW

Configuration: 320C & 320C L Excavators RAW00001-UP (MACHINE) POWERED BY 3066 Engine

**Disassembly and Assembly
3064 and 3066 Engines for Caterpillar Built Machines**

Media Number -SEN5553-10

Publication Date -01/05/2012

Date Updated -15/05/2012

i01131366

Crankshaft Front Seal - Remove

SMCS - 1160-011

Removal Procedure

Table 1

Required Tools			
Tool	Part Number	Part Description	Qty
A	1U-7600	Slide Hammer Puller	1

Start By:

- A. Remove the crankshaft pulley. Refer to Disassembly and Assembly, "Crankshaft Pulley - Remove and Install".

NOTICE

Keep all parts clean from contaminants.

Contaminants may cause rapid wear and shortened component life.

NOTICE

Care must be taken to ensure that fluids are contained during performance of inspection, maintenance, testing, adjusting and repair of the product. Be prepared to collect the fluid with suitable containers before opening any compartment or disassembling any component containing fluids.

Refer to Special Publication, NENG2500, "Caterpillar Tools and Shop Products Guide" for tools and supplies suitable to collect and contain fluids on Caterpillar products.

Dispose of all fluids according to local regulations and mandates.

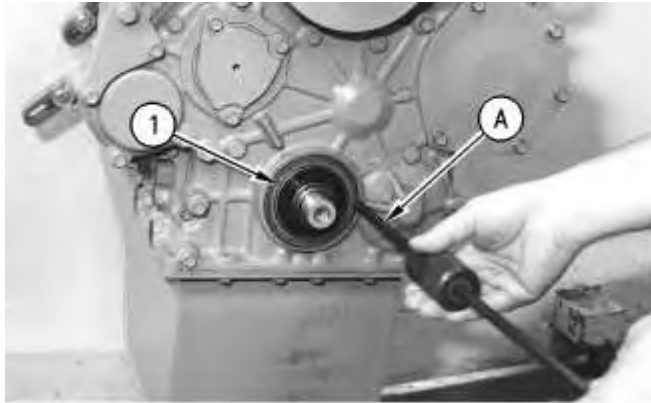

Illustration 1

g00529162

1. Drill three evenly spaced 3 mm (0.12 inch) holes in crankshaft front seal (1) .
2. Use Tool (A) and remove crankshaft front seal (1). Remove the seal evenly by alternating the position of Tool (A) from hole to hole.

Note: Do not damage the flange of the crankshaft during the removal process for the crankshaft front seal.

[Previous Screen](#)

Product: EXCAVATOR

Model: 320C EXCAVATOR RAW

Configuration: 320C & 320C L Excavators RAW00001-UP (MACHINE) POWERED BY 3066 Engine

Disassembly and Assembly 3064 and 3066 Engines for Caterpillar Built Machines

Media Number -SEN5553-10

Publication Date -01/05/2012

Date Updated -15/05/2012

i02080454

Crankshaft Front Seal - Install

SMCS - 1160-012

Installation Procedure

Table 1

Required Tools			
Tool	Part Number	Part Description	Qty
A	9U-6180	Front Seal Installer	1

NOTICE

Keep all parts clean from contaminants.

Contaminants may cause rapid wear and shortened component life.

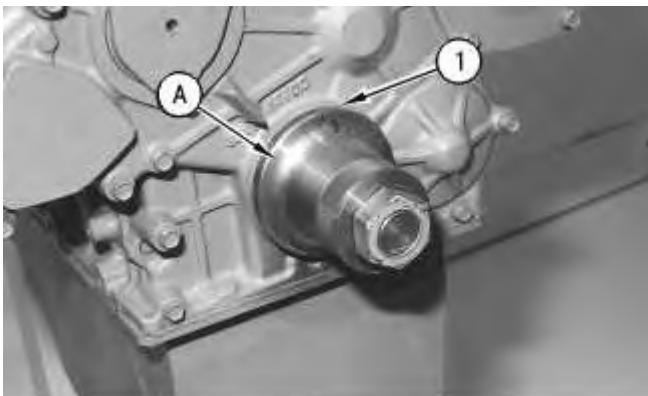

1. Clean the faces of all the mating parts. Apply a thin coat of clean engine oil to a new crankshaft front seal.
2. Install new crankshaft front seal (1) in the front housing with Tool (A) .
3. Remove Tooling (A) and check crankshaft front seal (1) for correct installation.
4. Apply clean engine oil to the face of the crankshaft pulley that will be in contact with the new crankshaft front seal.

End By: Install the crankshaft pulley. Refer to Disassembly and Assembly, "Crankshaft Pulley - Remove and Install".

Previous Screen

Product: EXCAVATOR

Model: 320C EXCAVATOR RAW

Configuration: 320C & 320C L Excavators RAW00001-UP (MACHINE) POWERED BY 3066 Engine

**Disassembly and Assembly
3064 and 3066 Engines for Caterpillar Built Machines**

Media Number -SEN5553-10

Publication Date -01/05/2012

Date Updated -15/05/2012

i01615339

Gear Group (Front) - Remove - Idler Gear Only

SMCS - 1206-011

Removal Procedure

Table 1

Required Tools			
Tool	Part Number	Part Description	Qty
A	9U-6148	Idler Shaft Puller	1
B	1P-0510	Driver Group	1

Start By:

- A. Remove the front housing. Refer to Disassembly and Assembly, "Housing (Front) - Remove".

NOTICE

Keep all parts clean from contaminants.

Contaminants may cause rapid wear and shortened component life.

NOTICE

Care must be taken to ensure that fluids are contained during performance of inspection, maintenance, testing, adjusting and repair of the product. Be prepared to collect the fluid with suitable containers

before opening any compartment or disassembling any component containing fluids.

Refer to Special Publication, NENG2500, "Caterpillar Tools and Shop Products Guide" for tools and supplies suitable to collect and contain fluids on Caterpillar products.

Dispose of all fluids according to local regulations and mandates.

Note: Before removal, ensure that the marks on the timing gears are in alignment. Align the fuel injection drive gear with the "33" mark with the "3" mark on the idler gear. Make an alignment of the "2" mark on the camshaft gear with the "22" mark on the idler gear. Align the "1" mark on the crankshaft gear with the "11" mark on the idler gear. The No. 1 cylinder is at the top center position when these marks are in alignment.

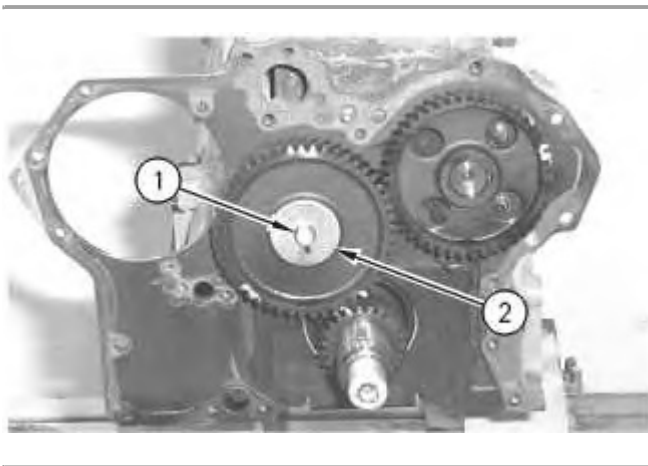

Illustration 1

g00611568

1. Remove idler gear bolt (1) and the washer from the idler gear shaft .
2. Remove thrust plate (2) from the idler gear shaft.



3. Remove idler gear (3) from the idler gear shaft.

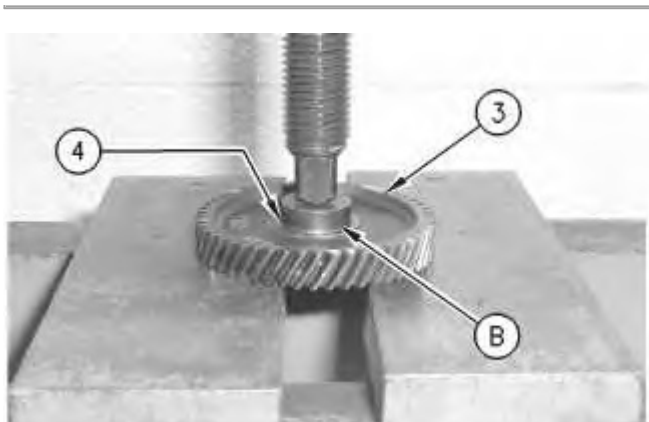

Illustration 3

4. If necessary, use Tool (B) to remove bushing (4) (not shown) from idler gear (3) .

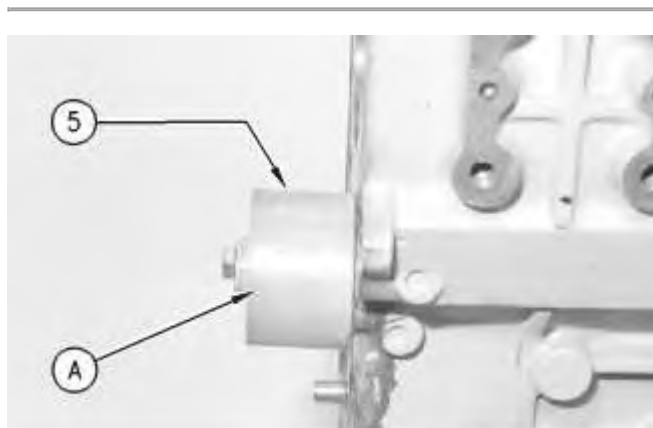

Illustration 4

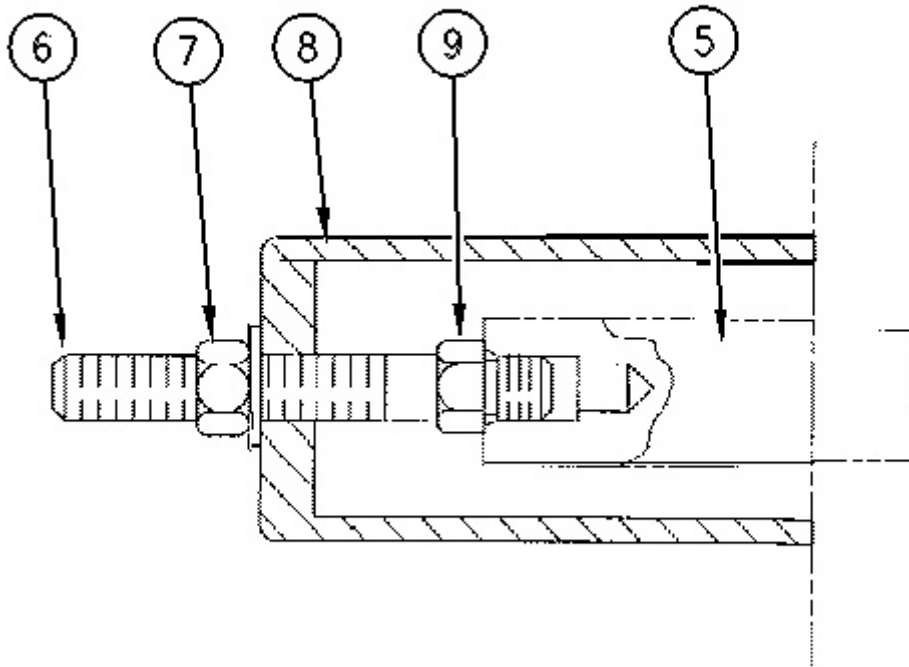

Illustration 5

g00611573

5. The following items are components of Tool (A) .
 - **9U-6147** Stud (6)
 - **6V-8231** Nut (7)
 - **9U-6146** Sleeve Assembly (8)
 - **8T-4244** Nut (9)
6. Use Tool (A) and remove idler shaft (5) from the cylinder block. Check the idler shaft for wear and damage. Replace the shaft, if necessary.

Note: See the following list for the removal of the other gears in the front gear group.

- In order to remove the camshaft gear, refer to Disassembly and Assembly, "Camshaft - Remove".
- In order to remove the fuel injection pump gear, refer to Disassembly and Assembly, "Fuel Injection Pump - Remove".
- In order to remove the gear from the engine oil pump, refer to Disassembly and Assembly, "Engine Oil Pump - Remove".
- In order to remove the crankshaft gear, refer to Disassembly and Assembly, "Crankshaft Gear - Remove and Install".

[Previous Screen](#)

Product: EXCAVATOR

Model: 320C EXCAVATOR RAW

Configuration: 320C & 320C L Excavators RAW00001-UP (MACHINE) POWERED BY 3066 Engine

Disassembly and Assembly 3064 and 3066 Engines for Caterpillar Built Machines

Media Number -SEN5553-10

Publication Date -01/05/2012

Date Updated -15/05/2012

i01615420

Gear Group (Front) - Install - Idler Gear Only

SMCS - 1206-012

Installation Procedure

Table 1

Required Tools			
Tool	Part Number	Part Description	Qty
A	1P-0510	Driver Group	1

NOTICE

Keep all parts clean from contaminants.

Contaminants may cause rapid wear and shortened component life.

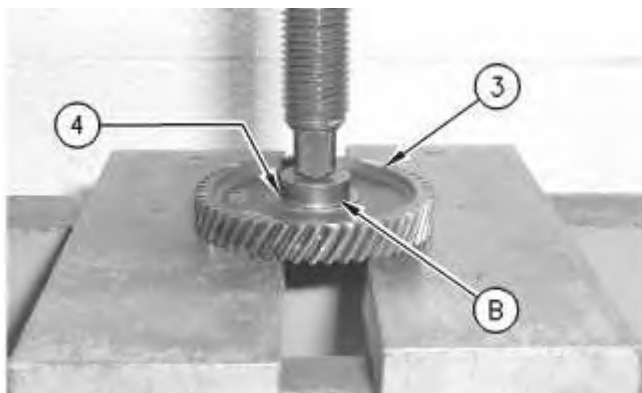



Suggest:

If the above button click is invalid.

Please download this document

first, and then click the above link

to download the complete manual.

Thank you so much for reading

1. Use Tool (A) to install a new bushing (4) (not shown), if the bushing was removed.

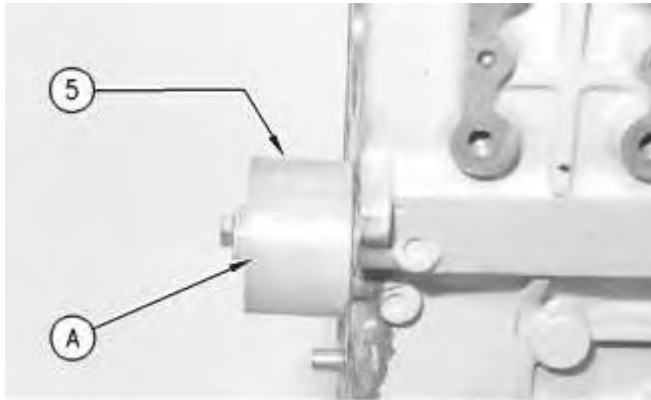

Illustration 2

2. Install idler shaft (5) onto the cylinder block.

Note: When the idler shaft is installed, ensure that the oil hole of the shaft is up. If necessary, cool the idler shaft to 0 °C (32 °F) before installation. The temperature of the idler shaft is lowered in order to ease the installation of the idler shaft.



Illustration 3

Note: Ensure that the marks on the timing gears are in alignment. Align the fuel injection drive gear with the "33" mark with the "3" mark on idler gear. Make an alignment of the "2" mark on the camshaft gear with the "22" mark on the idler gear. Align the "1" mark on the crankshaft gear with the "11" mark on the idler gear. The No. 1 cylinder is at the top center position when these marks are in alignment.

3. Install idler gear (3) onto the idler shaft.

<https://www.ebooklibonline.com>

Hello dear friend!

Thank you very much for reading.

Enter the link into your browser.

The full manual is available for immediate download.

<https://www.ebooklibonline.com>