



Service Repair Manual

Model

320C, 320C L 320CL, 320C LN
320CLN Excavator

[Previous Screen](#)

Product: EXCAVATOR

Model: 320C EXCAVATOR GLA

Configuration: 320C, 320C L, 320C LN Excavators GLA00001-UP (MACHINE) POWERED BY 3066 Engine

Disassembly and Assembly 320C Excavator Machine Systems

Media Number -REN3826-16

Publication Date -01/11/2014

Date Updated -30/03/2016

i01972529

Swing Motor - Install

SMCS - 5058-012-ZW

Installation Procedure

Table 1

Required Tools			
Tool	Part Number	Part Description	Qty
A	FT-2674	Vacuum Cap	1
B	138-7573	Link Bracket	2
C	1U-8846	Gasket Sealant	

NOTICE

Care must be taken to ensure that fluids are contained during performance of inspection, maintenance, testing, adjusting, and repair of the product. Be prepared to collect the fluid with suitable containers before opening any compartment or disassembling any component containing fluids.

Refer to Special Publication, NENG2500, "Dealer Service Tool Catalog" for tools and supplies suitable to collect and contain fluids on Cat[®] products.

Dispose of all fluids according to local regulations and mandates.

1. Prior to the installation of the swing motor, make sure that the mating surfaces of the swing motor and the swing drive are thoroughly clean and dry.

2. Apply Tooling (C) on the mating surface of the swing motor and the swing drive housing.

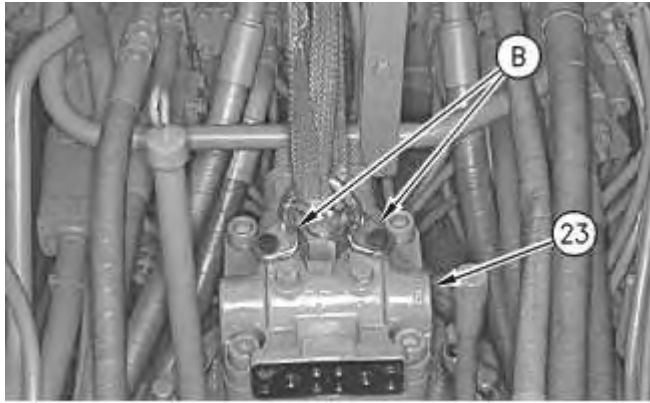

Illustration 1

g00694494

3. Attach Tooling (B) and a suitable lifting device to swing motor (23). The weight of swing motor (23) is approximately 55 kg (120 lb).

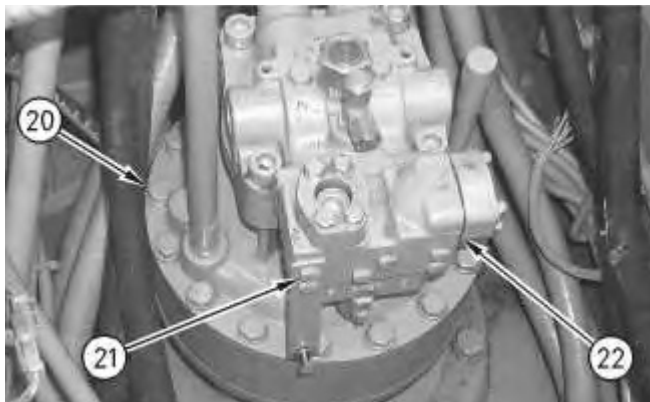

Illustration 2

g00694484

4. Install the washers and bolts (20).
5. Tighten bolts (20) to a torque of 240 ± 40 N·m (177 ± 30 lb ft).
6. Install anti-reaction valve (22). Install the washers and bolts (21). Tighten bolts (21) to a torque of 55 ± 10 N·m (40 ± 7 lb ft).



<https://www.ebooklibonline.com>

Hello dear friend!

Thank you very much for reading.

Enter the link into your browser.

The full manual is available for immediate download.

<https://www.ebooklibonline.com>

7. Remove the cap to the hydraulic tank. Attach Tooling (A) to the hydraulic tank.

Note: Hook up the air to Tooling (A) in order to create a vacuum in the hydraulic system. This will minimize the leakage from the hose assemblies.

Note: Replace the O-ring seals that are used in the ends of the hose assemblies.

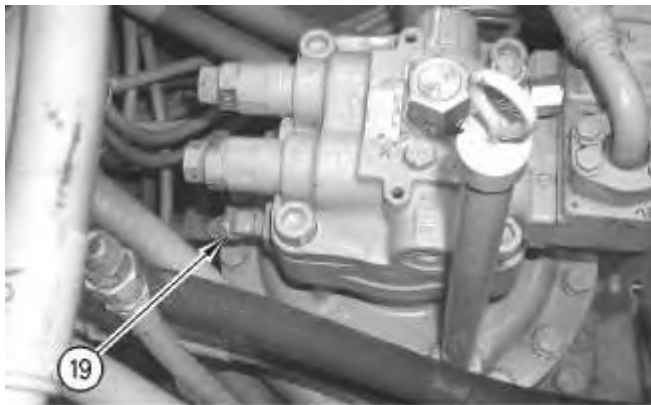

Illustration 4

8. Connect hose assembly (19).

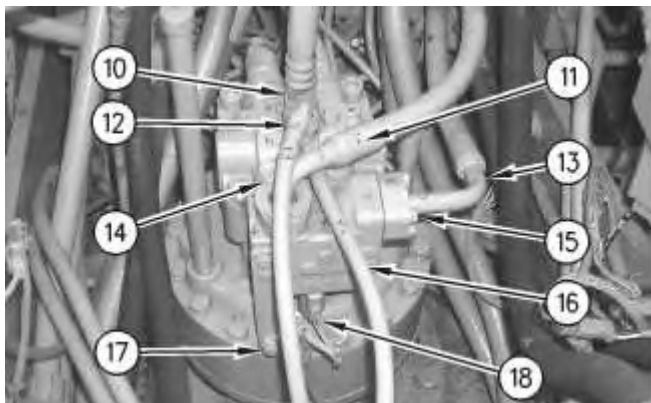

Illustration 5

9. Connect hose assembly (13).
10. Install the split flanges, the washers and bolts (15).
11. Connect hose assembly (16).
12. Connect hose assembly (11).
13. Install the split flanges, the washers, and bolts (14).
14. Connect hose assembly (12).

15. Connect hose assembly (10).
16. Connect harness assembly (18).
17. Install the clip, the washer, and bolt (17).

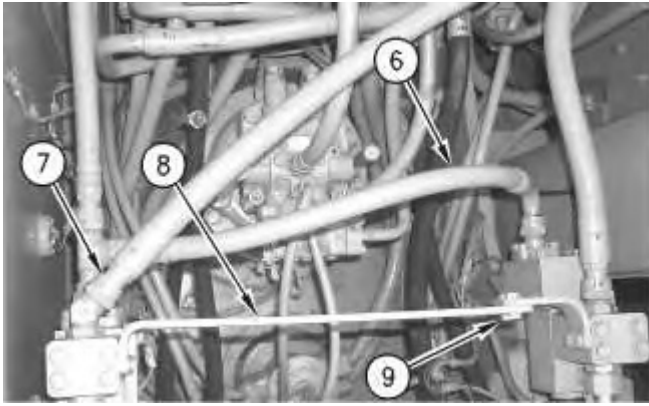

Illustration 6
Typical example

g00694459

18. Connect hose assembly (7) (If Equipped).
19. Install hose assembly (6) (If Equipped).
20. Install brace (8) with washers and bolts (9) (If Equipped).

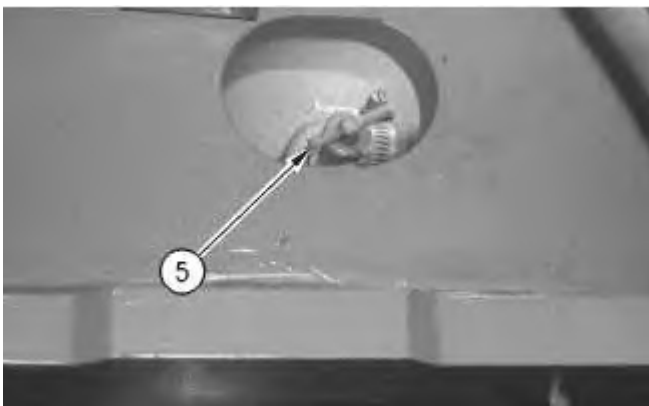

Illustration 7

g00694353

21. Make sure that the drain valve (5) is closed.
22. Remove Tooling (A) and install the cap to the hydraulic tank.

NOTICE

To avoid system damage, make sure that the hydraulic motor is properly filled with hydraulic oil before start-up.

-
23. Install high efficiency filters in place of the pilot filter, the case drain filter, and the return filter.

Note: High efficiency filters should not be run for more than 250 hours before you change back to the standard filters.

24. Fill the hydraulic oil tank and the swing drive with clean hydraulic oil to the correct level.

Reference: Refer to Operation and Maintenance Manual, "Lubricant Viscosities" for the proper oil viscosity.

Reference: Refer to Operation and Maintenance Manual, "Hydraulic System Oil Level - Check" and Operation and Maintenance Manual, "Swing Drive Oil Level - Check" for the correct filling procedures.

25. Start the engine, and check the operation of the swing drive. Also, check for leaks. Stop the engine.

26. Obtain a hydraulic oil sample from the main S·O·S port.

Reference: Refer to Operation and Maintenance Manual, "Sampling Interval and Location of Sampling Valve" for the correct location.

27. If the S·O·S sample exceeds ISO 18/15, flush the hydraulic system.

Reference: Refer to Contamination Control Guidelines, SEBF8436, "Hydraulic System Flushing Procedure for 320C Hydraulic Excavators" for further information.

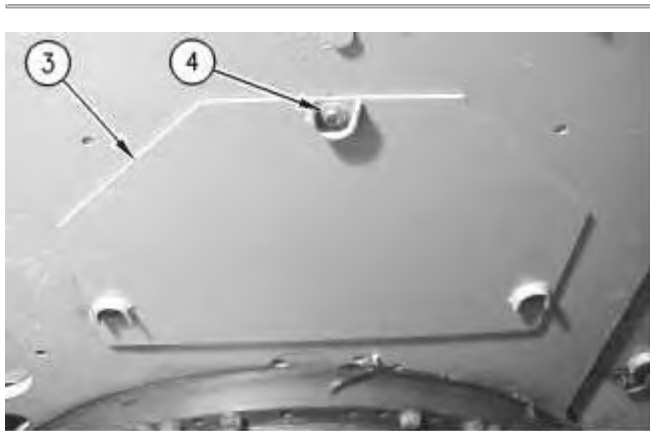

Illustration 8

g00694245

28. Install the washers and bolts (4) in order to install access cover (3) that is under the main control valve.
-

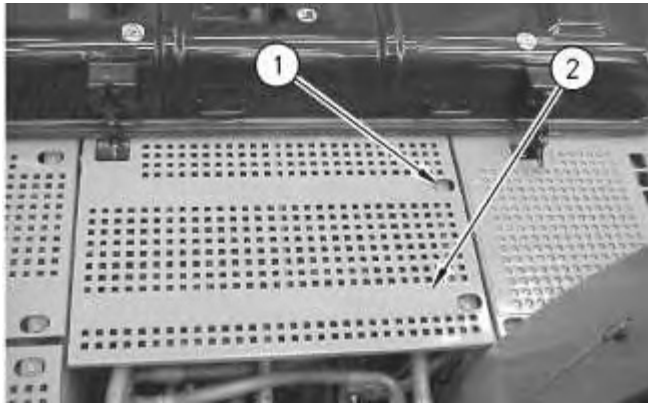

Illustration 9

g00950370

29. Install the washers and bolts (1) in order to install cover (2).

Previous Screen

Product: EXCAVATOR

Model: 320C EXCAVATOR GLA

Configuration: 320C, 320C L, 320C LN Excavators GLA00001-UP (MACHINE) POWERED BY 3066 Engine

**Disassembly and Assembly
320C Excavator Machine Systems**

Media Number -REN3826-16

Publication Date -01/11/2014

Date Updated -30/03/2016

i01972334

Swing Drive - Remove

SMCS - 5459-011

Removal Procedure

Table 1

Required Tools			
Tool	Part Number	Part Description	Qty
A	138-7574	Link Bracket	2
B		Forcing Screw (20 mm X 100 mm)	2

Start By:

- a. Remove the swing motor. Refer to Disassembly and Assembly, "Swing Motor - Remove" in this manual.

NOTICE

Keep all parts clean from contaminants.

Contamination of the hydraulic system with foreign material will reduce the service life of the hydraulic system components.

To prevent contaminants from entering the hydraulic system, always plug or cap the lines, fittings, or hoses as they are disconnected. Cover any disassembled components and clean them properly before assembly.

Clean the hydraulic system properly after any major component exchange or especially after a component failure, to remove any contamination.

NOTICE

Care must be taken to ensure that fluids are contained during performance of inspection, maintenance, testing, adjusting, and repair of the product. Be prepared to collect the fluid with suitable containers before opening any compartment or disassembling any component containing fluids.

Refer to Special Publication, NENG2500, "Dealer Service Tool Catalog" for tools and supplies suitable to collect and contain fluids on Cat[®] products.

Dispose of all fluids according to local regulations and mandates.

1. Thoroughly clean the area around the swing drive prior to removal.
2. Put identification marks on the swing drive in order to mark the drive's location for installation purposes.

Note: It may be necessary to remove the drain hose for the swing drive in order to access the mount bolts in the rear of the drive.

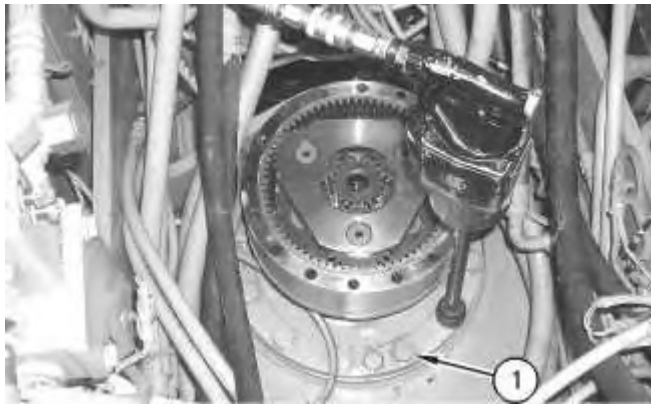

Illustration 1

g00694361

3. Remove bolts (1) and the washers that secure the swing drive to the main frame.
-

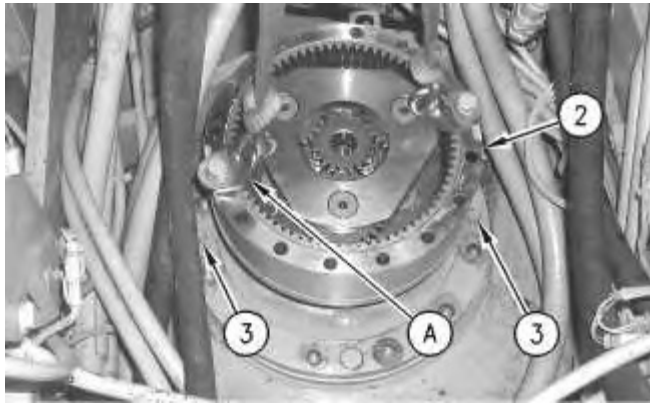

Illustration 2

g00694371

4. Attach Tooling (A) and a suitable lifting device to swing drive (2), as shown.
5. Remove corks (3) from the threaded holes in the swing drive housing.

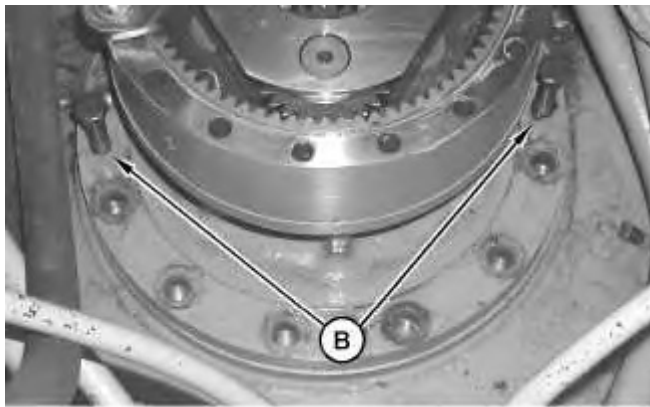
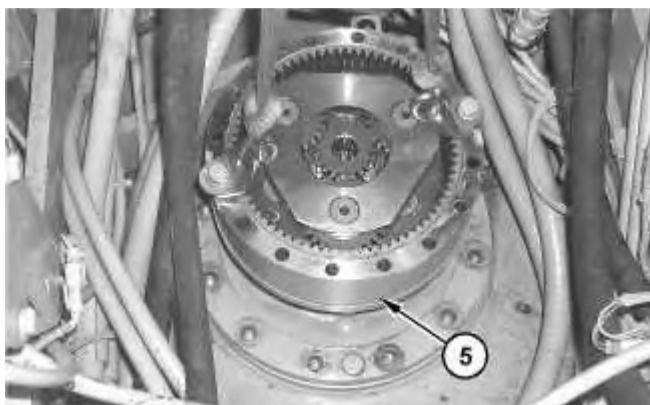

Illustration 3

g01023898

6. Install Tooling (B) in each threaded hole in the swing drive housing.
7. Slowly tighten one forcing screw for no more than two turns, and then tighten the other forcing screw for no more than two turns. At the same time keep tension on the swing drive with the hoist. Tighten the forcing screws evenly in this manner in order to separate the swing drive from the main frame.



8. Remove swing drive (5) from the machine. The weight of swing drive (5) is approximately 190 kg (420 lb).

Previous Screen

Product: EXCAVATOR

Model: 320C EXCAVATOR GLA

Configuration: 320C, 320C L, 320C LN Excavators GLA00001-UP (MACHINE) POWERED BY 3066 Engine

**Disassembly and Assembly
320C Excavator Machine Systems**

Media Number -REN3826-16

Publication Date -01/11/2014

Date Updated -30/03/2016

i01916277

Swing Drive - Disassemble

SMCS - 5459-015

Disassembly Procedure

Table 1

Required Tools			
Tool	Part Number	Part Description	Qty
A	5P-5197	Retaining Ring Pliers	1
	1U-8759	Tip Set	1
B	1P-0520	Driver Group	1

Start By:

- a. Remove the swing drive. Refer to Disassembly and Assembly, "Swing Drive - Remove" for the machine that is being serviced.

Note: Cleanliness is an important factor. Before the disassembly procedure, the exterior of the component should be thoroughly cleaned. This will prevent dirt from entering the internal mechanism.

NOTICE

Keep all parts clean from contaminants.

Contamination of the hydraulic system with foreign material will reduce the service life of the hydraulic system components.

To prevent contaminants from entering the hydraulic system, always plug or cap the lines, fittings, or hoses as they are disconnected. Cover

any disassembled components and clean them properly before assembly.

Clean the hydraulic system properly after any major component exchange or especially after a component failure, to remove any contamination.

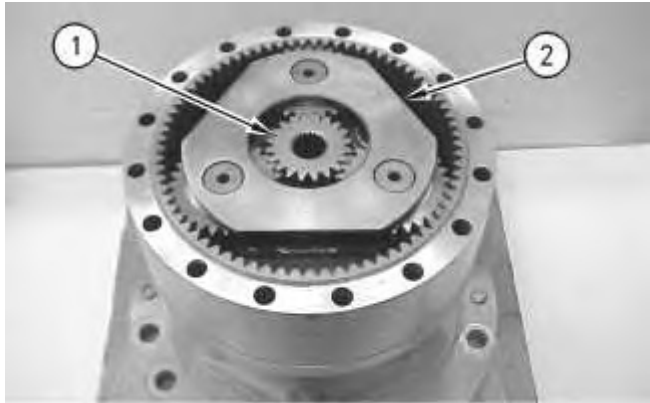

Illustration 1

g00702449

1. Remove sun gear (1) from carrier assembly (2).

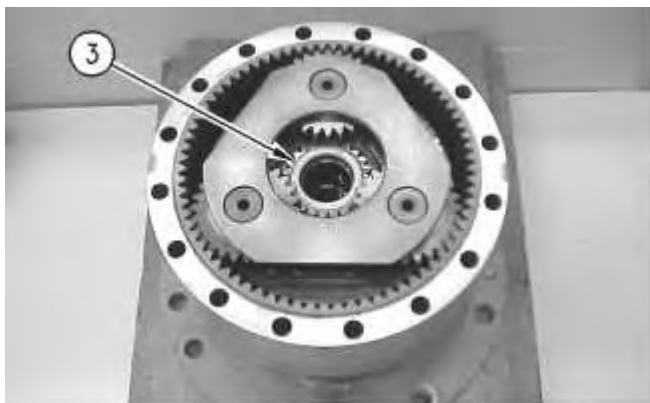

Illustration 2

g00702450

2. Remove spacer (3) from the carrier assembly.
-

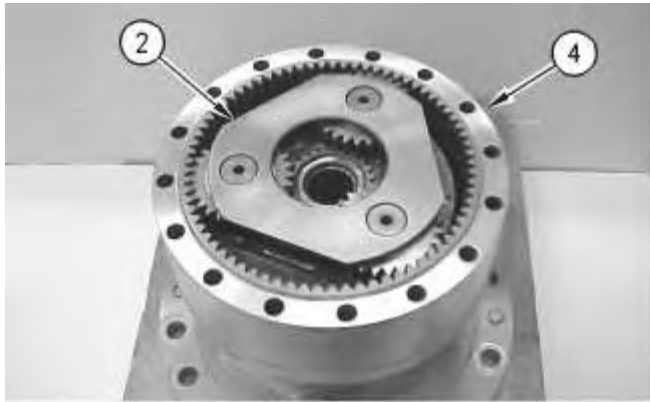

Illustration 3

g00702451

3. Remove carrier assembly (2) from ring gear (4).

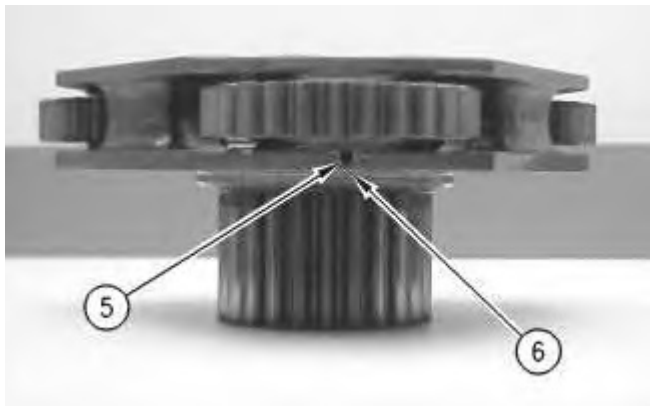

Illustration 4

g00702452

4. Drive roll pin (5) into shaft (6). Remove shaft (6) and the gear assembly from the carrier assembly.

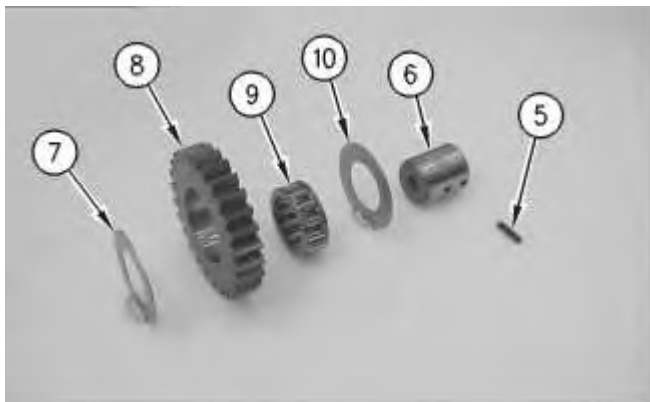

Illustration 5

g00702456

5. Disassemble the gear assembly, as follows: washer (7), gear (8), bearing (9), and washer (10). Remove roll pin (5) from shaft (6).

6. Repeat Step 4 through Step 5 for the remaining gear assemblies.

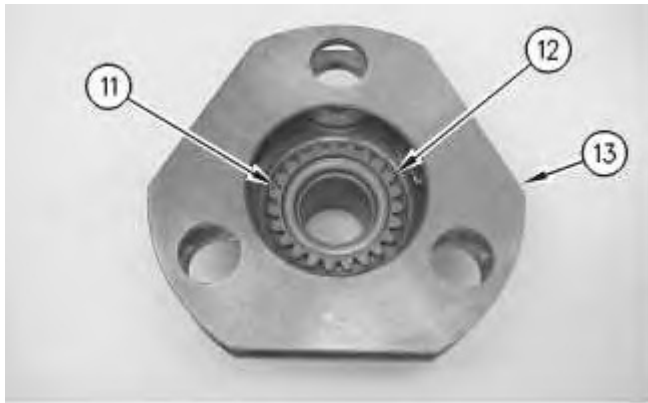

Illustration 6

g00702457

7. Remove retaining ring (11) from sun gear (12). Remove carrier (13) from the sun gear.



Illustration 7

g00702459

8. Remove retaining ring (14) from the sun gear.

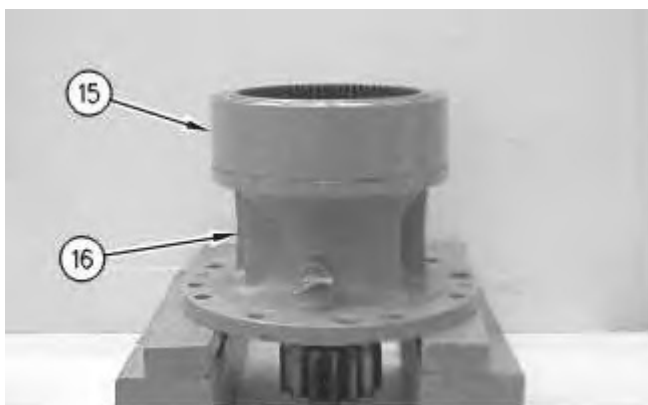

Illustration 8

g00702583

9. Use two people in order to remove ring gear (15) from housing (16). Weight of ring gear (15) is approximately 29 kg (65 lb).

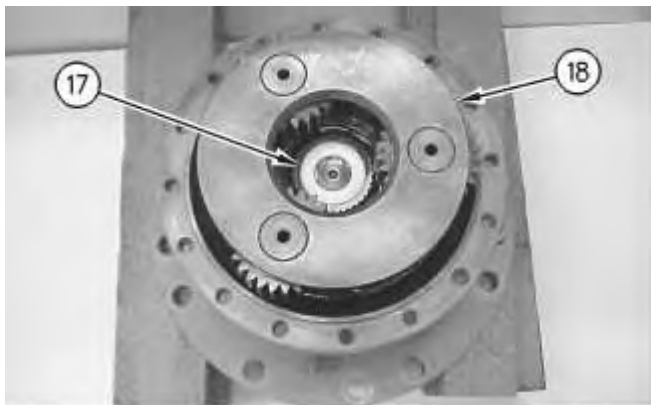

Illustration 9

g00702584

10. Remove spacer (17) from carrier assembly (18).

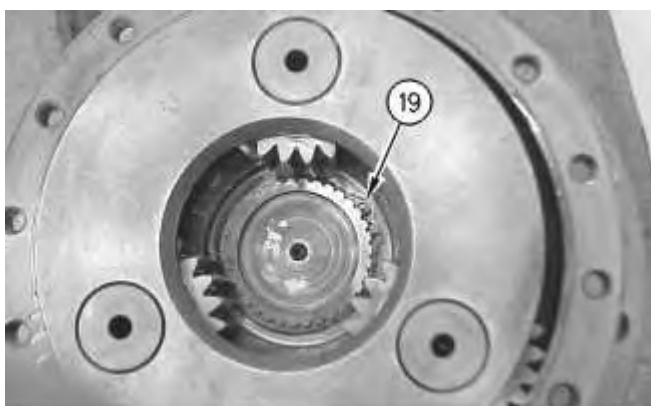

Illustration 10

g00702596

11. Use Tooling (A) to remove retaining ring (19).



Illustration 11

g00702611

12. Remove carrier assembly (18) from the housing.
-

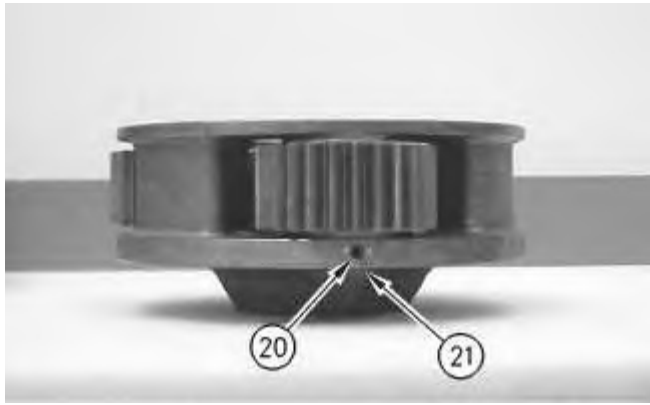

Illustration 12

g00702640

13. Drive roll pin (20) into shaft (21). Remove shaft (21) and the gear assembly from the carrier assembly.

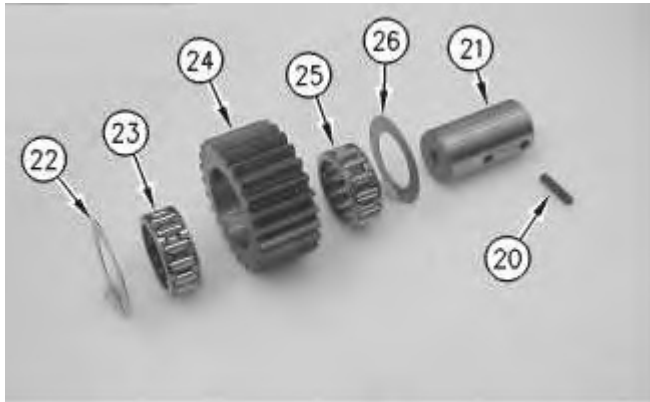

Illustration 13

g00702648

14. Disassemble the gear assembly, as follows: washer (22), bearing (23), gear (24), bearing (25), and washer (26). Remove roll pin (20) from shaft (21).
15. Repeat Step 13 through Step 14 for the remaining gear assemblies.

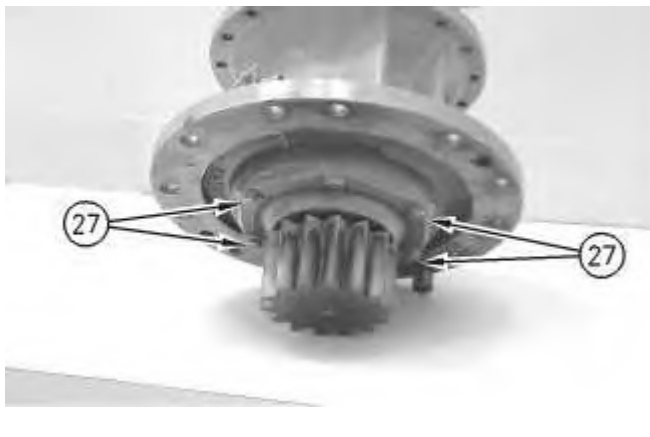

Illustration 14

g00702659

16. Remove four bolts (27) from the housing.

Note: Do not remove the other two bolts (27) at this time. These two bolts (27) will be used to transport the assembly to the press.

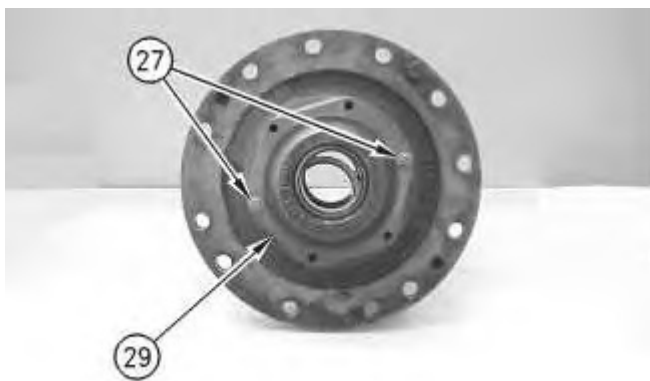

Illustration 15

g00703241

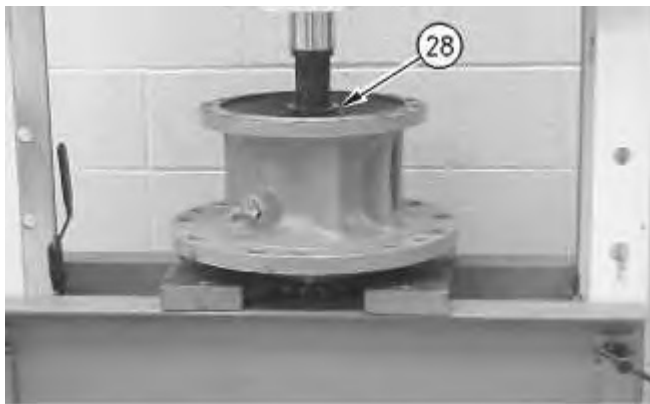

Illustration 16

g00702664

17. Remove remaining bolts (27). Use a suitable press in order to remove shaft (28) from the housing. Remove cage (29) from the housing.

Note: The bearing may come off with the pinion or the bearing may stay in the housing.



18. Remove O-ring seal (30) from the cage. Remove lip type seals (31) from the cage.

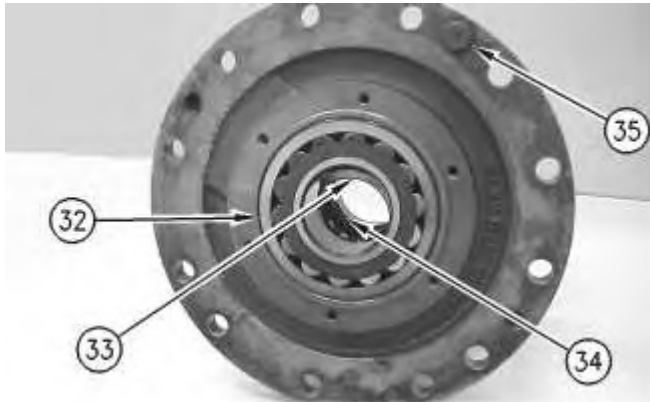

Illustration 18



Illustration 19

19. Use a suitable press and Tooling (B) in order to remove bearing (34), spacer (33), and bearing (32) from the housing. Remove alignment pin (35) from the housing.



Illustration 20

20. Remove drain valve (36) from the housing.

[Copyright 1993 - 2019 Caterpillar Inc.](#)

Sat Sep 21 23:47:31 UTC+0800 2019

[All Rights Reserved.](#)

[Private Network For SIS Licensees.](#)

[Previous Screen](#)

Product: EXCAVATOR

Model: 320C EXCAVATOR GLA

Configuration: 320C, 320C L, 320C LN Excavators GLA00001-UP (MACHINE) POWERED BY 3066 Engine

Disassembly and Assembly 320C Excavator Machine Systems

Media Number -REN3826-16

Publication Date -01/11/2014

Date Updated -30/03/2016

i02015036

Swing Drive - Assemble

SMCS - 5459-016

Assembly Procedure

Table 1

Required Tools			
Tool	Part Number	Part Description	Qty
A	138-7574	Link Bracket	2
B	5P-5197	Retaining Ring Pliers	1
	1U-8759	Tip Set	1
C		Threaded Guide Stud (M16×2.00×140mm)	2
D	1U-6396	O-Ring Assembly Compound	
E	4C-9613	Silicone Sealant	
F	5P-3931	Anti-Seize Compound	

Note: Cleanliness is an important factor. Before assembly, all parts should be thoroughly cleaned in cleaning fluid. Allow the parts to air dry. Wiping cloths or rags should not be used to dry parts. Lint may be deposited on the parts which may cause later trouble. Inspect all parts. If any parts are worn or damaged, use new parts for replacement. All disassembly and all assembly procedures must be performed on a clean work surface and in a clean hydraulic area. Keep cleaned parts covered and protected at all times.

Note: O-rings, gaskets, and seals should always be replaced. A used O-ring may not have the same sealing properties as a new O-ring. Use Tooling (D) during the assembly procedure.

Note: Apply a light film of hydraulic oil to all components before assembly.

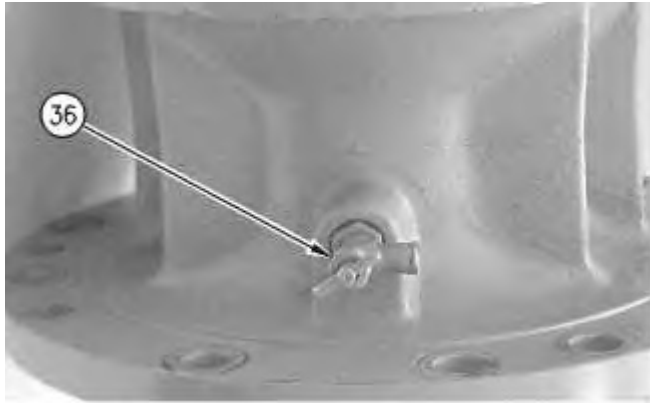

Illustration 1

g00703249

1. Install drain valve (36) into the housing.



Illustration 2

g00703242

2. Install O-ring seal (30) into the cage. Install lip type seals (31) into the cage.

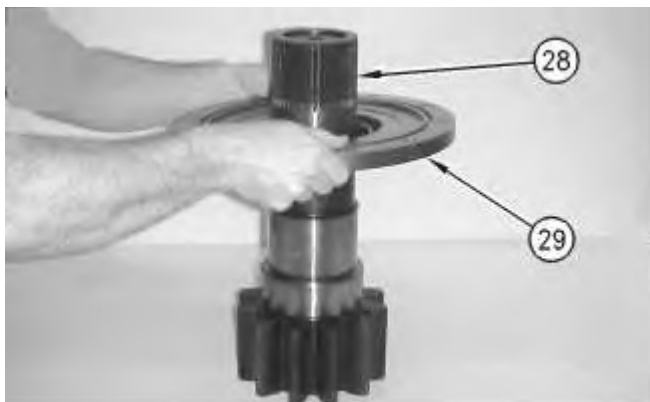

Illustration 3

g00703692

3. Install cage (29) onto shaft (28).



Illustration 4

g00703693

4. Raise the temperature of bearing (32) to 135 °C (275 °F). Install bearing (32) onto shaft (28).

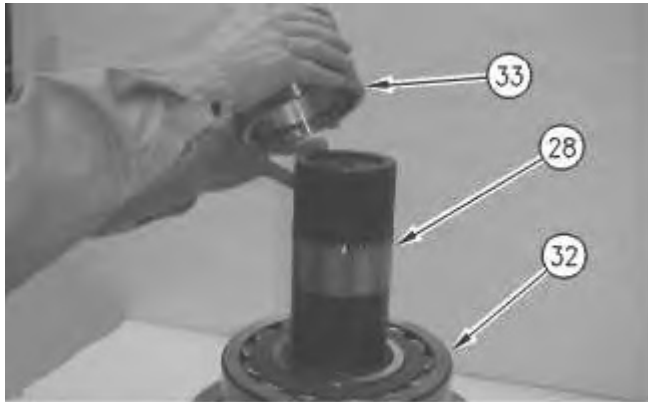

Illustration 5

g00703694

5. Install spacer (33) onto shaft (28). Install spacer (33) with relief against bearing (32).



Illustration 6

g00703695

6. Raise the temperature of bearing (34) to 135 °C (275 °F). Install bearing (34) onto shaft (28) against spacer (33).

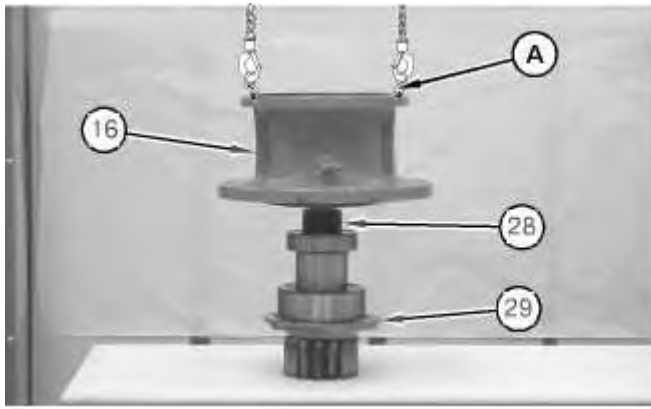

Illustration 7

g01041742

7. Place shaft assembly (28) onto a flat surface. Install Tooling (A) and a suitable lifting device onto housing (16). Apply Tooling (E) to the face of cage (29). Apply Tooling (F) to the inside diameters of the housing. Raise the temperature of housing (16) to 93 °C (200 °F). Use a suitable lifting device and lower the housing onto the shaft assembly.



Illustration 8

g00703697

8. Install bolts (27) into the housing. Install alignment pin (35) into the housing.

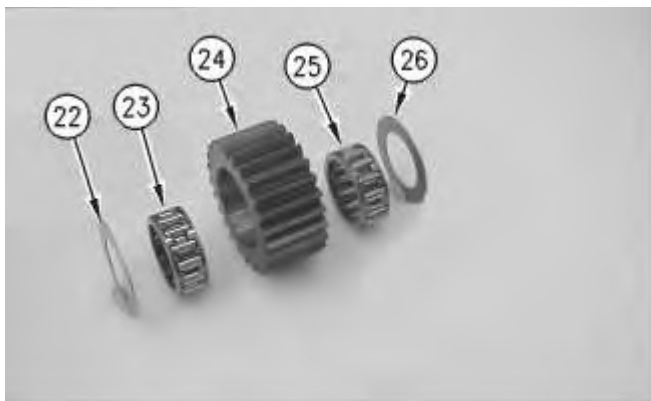

Illustration 9

g00703698

9. Assemble the gear assembly, as follows: washer (22), bearing (23), gear (24), bearing (25), and washer (26).

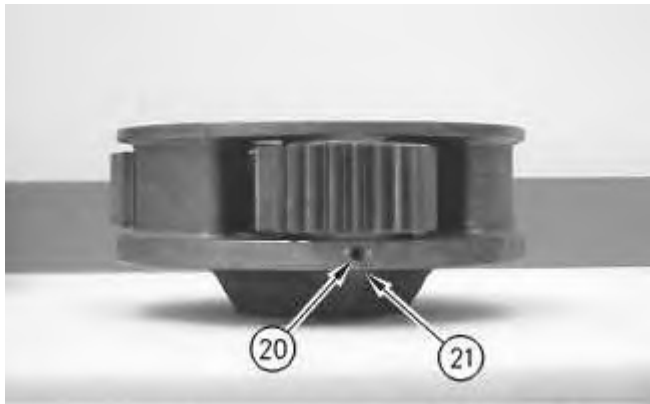
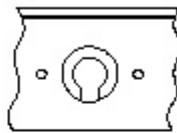

Illustration 10

g00702640



OR

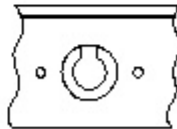

Illustration 11

g00703700

10. Use a deburring tool in order to remove the metal burr from the openings in the carrier. Install shaft (21) and the gear assembly into the carrier assembly. Drive roll pin (20) into shaft (21). Orient the split in roll pin (20) vertically to the carrier. Align the split in the roll pin to the top or to the bottom. Make a stake mark on each side of the roll pin hole in the carrier. Each stake mark should be approximately 2.25 ± 0.75 mm (0.09 ± 0.03 inch) from the outside diameter of the roll pin hole.
11. Repeat Step 9 through Step 10 for the remaining gear assemblies.
-



Illustration 12

g00702611

12. Install carrier assembly (18) into the housing.

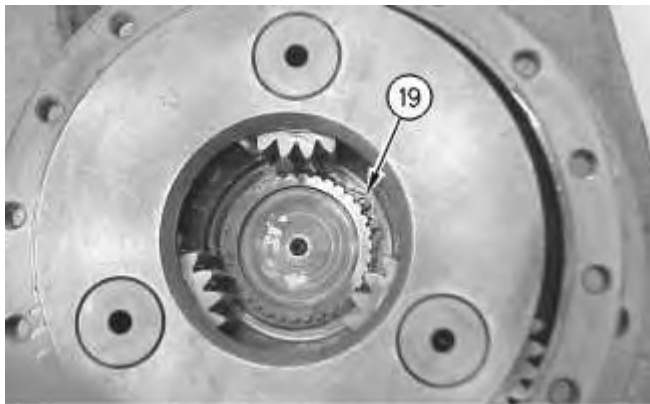

Illustration 13

g00702596

13. Use Tooling (B) to install retaining ring (19).

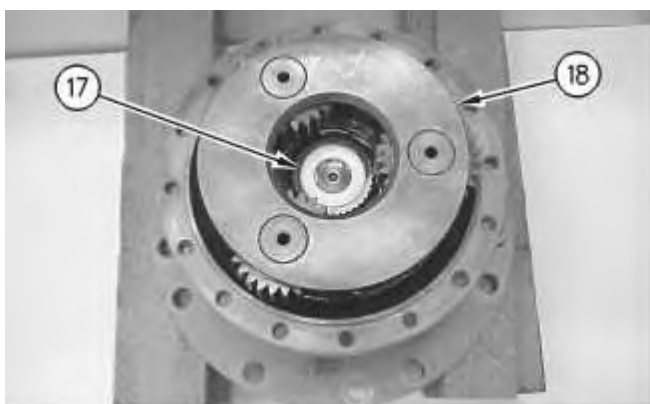

Illustration 14

g00702584

14. Install spacer (17) into carrier assembly (18).

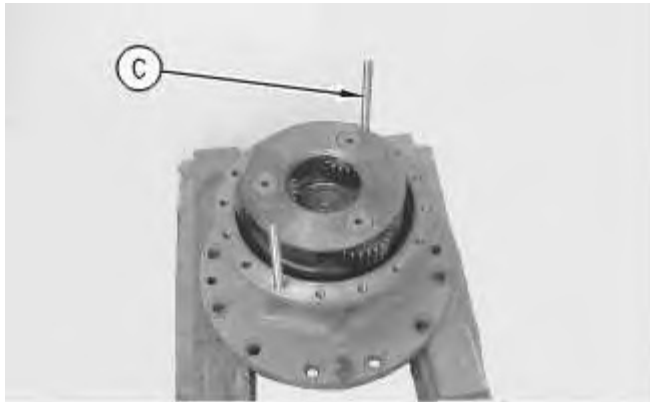

Illustration 15

g00703699

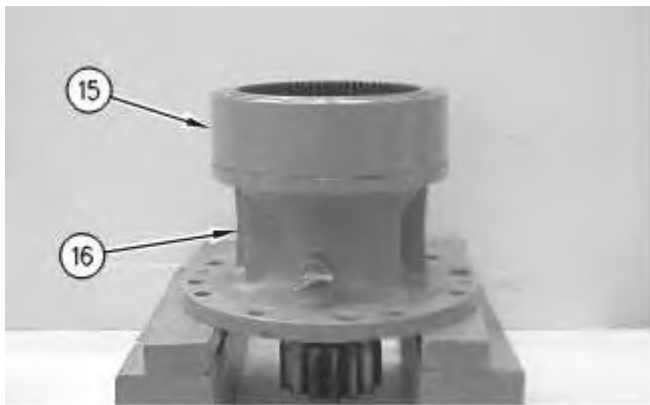

Illustration 16

g00702583

15. Apply Tooling (E) to the face of housing (16). Install Tooling (C) in order to help align the housing and the ring gear. Use two people in order to install ring gear (15) onto housing (16). Weight of ring gear (15) is approximately 29 kg (65 lb).



Illustration 17

g00702459

16. Install retaining ring (14) into the sun gear.

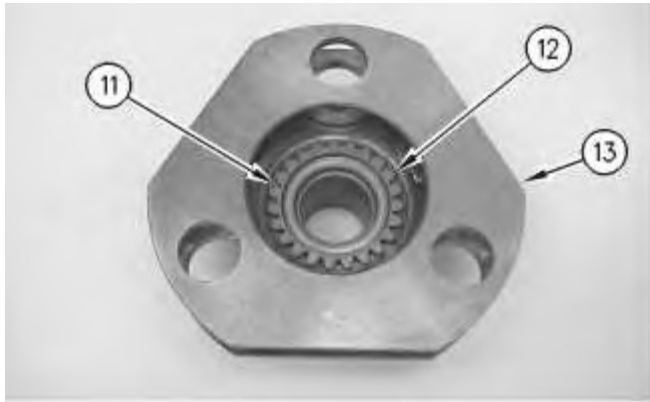

Illustration 18

g00702457

17. Install carrier (13) into the sun gear. Install retaining ring (11) into sun gear (12).

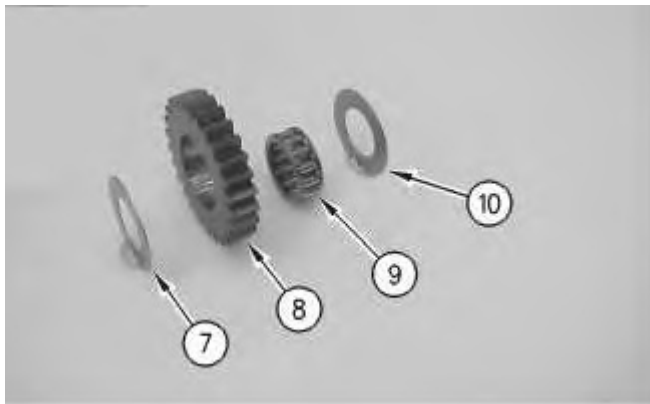

Illustration 19

g00703707

18. Assemble the gear assembly, as follows: washer (7), gear (8), bearing (9), and washer (10).

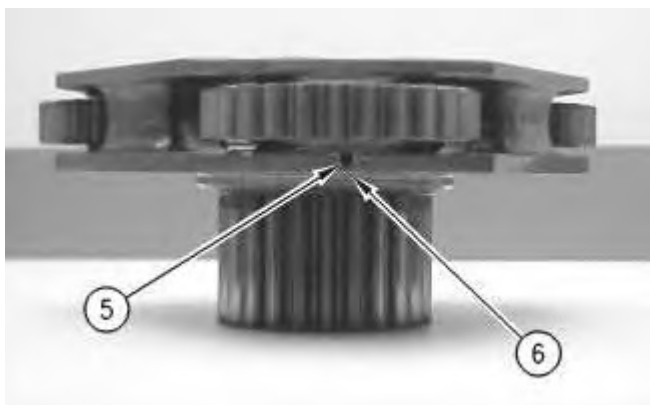

Illustration 20

g00702452



Suggest:

If the above button click is invalid.

Please download this document

first, and then click the above link

to download the complete manual.

Thank you so much for reading

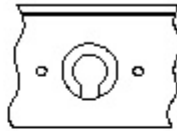

OR

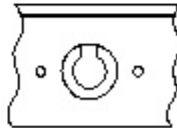

Illustration 21

g00703700

19. Use a deburring tool in order to remove the metal burr from the openings in the carrier. Install shaft (6) and the gear assembly into the carrier assembly. Drive roll pin (5) into shaft (6). Orient the split in roll pin (5) vertically to the carrier. Align the split in the roll pin to the top or to the bottom. Make a stake mark on each side of the roll pin hole in the carrier. Each stake mark should be approximately 2.25 ± 0.75 mm (0.09 ± 0.03 inch) from the outside diameter of the roll pin hole.
20. Repeat Step 18 through Step 19 for the remaining gear assemblies.

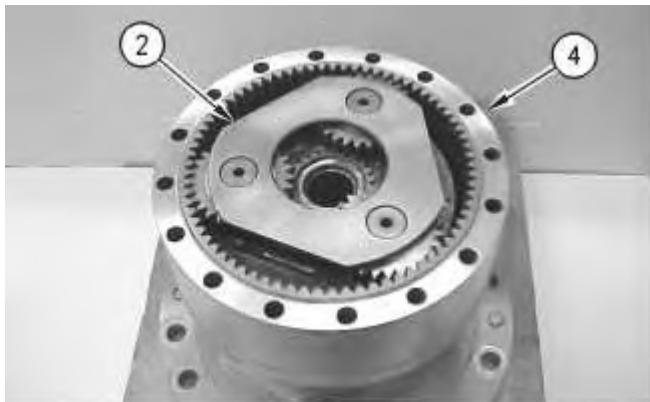

Illustration 22

g00702451

21. Install carrier assembly (2) into ring gear (4).
-

<https://www.ebooklibonline.com>

Hello dear friend!

Thank you very much for reading.

Enter the link into your browser.

The full manual is available for immediate download.

<https://www.ebooklibonline.com>