



Service Repair Manual

Model

320C and 320C L Excavator

[Previous Screen](#)

Product: EXCAVATOR

Model: 320C EXCAVATOR BDC

Configuration: 320C & 320C L Excavators BDC00001-UP (MACHINE) POWERED BY 3066 Engine

Disassembly and Assembly 320C Excavator Machine Systems

Media Number -REN3826-16

Publication Date -01/11/2014

Date Updated -30/03/2016

i06619175

Stick Cylinder - Remove and Install

SMCS - 5458-010

Removal Procedure

Start By:

- a. Relieve hydraulic system pressure.



Cylinders equipped with lock valves can remain pressurized for very long periods of time, even with the hoses removed.

Failure to relieve pressure before removing a lock valve or disassembling a cylinder can result in personal injury or death.

Ensure all pressure is relieved before removing a lock valve or disassembling a cylinder.

NOTICE

Care must be taken to ensure that fluids are contained during performance of inspection, maintenance, testing, adjusting, and repair of the product. Be prepared to collect the fluid with suitable containers before opening any compartment or disassembling any component containing fluids.

Refer to Special Publication, NENG2500, "Dealer Service Tool Catalog" for tools and supplies suitable to collect and contain fluids on Cat® products.

Dispose of all fluids according to local regulations and mandates.

WARNING

Personal injury can result from hydraulic oil pressure and hot oil.

Hydraulic oil pressure can remain in the hydraulic system after the engine has been stopped. Serious injury can be caused if this pressure is not released before any service is done on the hydraulic system.

Make sure all of the work tools have been lowered to the ground, and the oil is cool before removing any components or lines. Remove the oil filler cap only when the engine is stopped, and the filler cap is cool enough to touch with your bare hand.

1. Relieve hydraulic system pressure.



Illustration 1

g00689635

2. Attach a suitable lifting device to stick cylinder (1), as shown.
3. Put slight lifting tension on the stick cylinder.

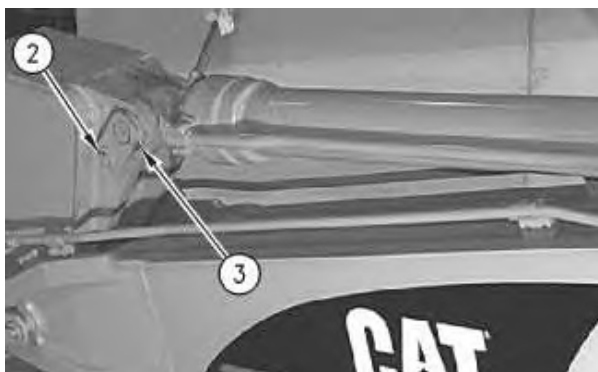

Illustration 2

g00689637

4. Remove retaining bolt (2).
 5. Remove pin assembly (3) and the spacer.
-

<https://www.ebooklibonline.com>

Hello dear friend!

Thank you very much for reading.

Enter the link into your browser.

The full manual is available for immediate download.

<https://www.ebooklibonline.com>

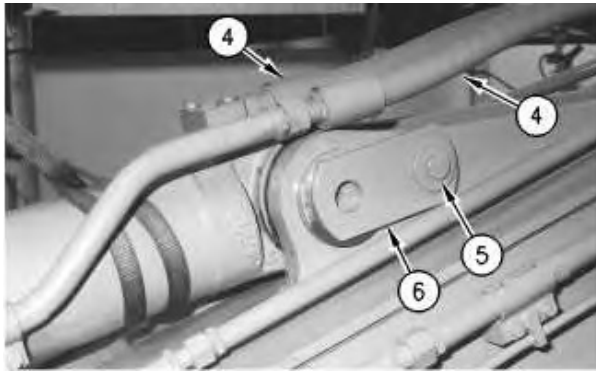

Illustration 3

g00689639

6. Disconnect hose assemblies (4).
7. Remove retaining bolt (5).
8. Remove pin assembly (6) and the spacer.
9. Remove the stick cylinder from the machine. The weight of the stick cylinder is approximately 278 kg (615 lb).

Note: Some machines may be equipped with shims between the stick cylinder and the stick at the pin bore. Put identification marks on the shims for assembly purposes.

10. Remove the shims from the stick.

Disassembly and Assembly Information

Table 1

Required Tools			
Tool	Part Number	Part Description	Qty
A	127-4904	Hydraulic Cylinder Repair Stand Gp	1
	1P-0520	Driver Gp	1
	9U-7868	Spanner Wrench	1
	127-8064	Adapter Plate Gp	1
	195-4609	Seal Pick	1
B	4C-4032	Bearing Mount Compound	1
C	5P-0960	Grease Cartridge	1



Cylinders equipped with lock valves can remain pressurized for very long periods of time, even with the hoses removed.

Failure to relieve pressure before removing a lock valve or disassembling a cylinder can result in personal injury or death.

Ensure all pressure is relieved before removing a lock valve or disassembling a cylinder.

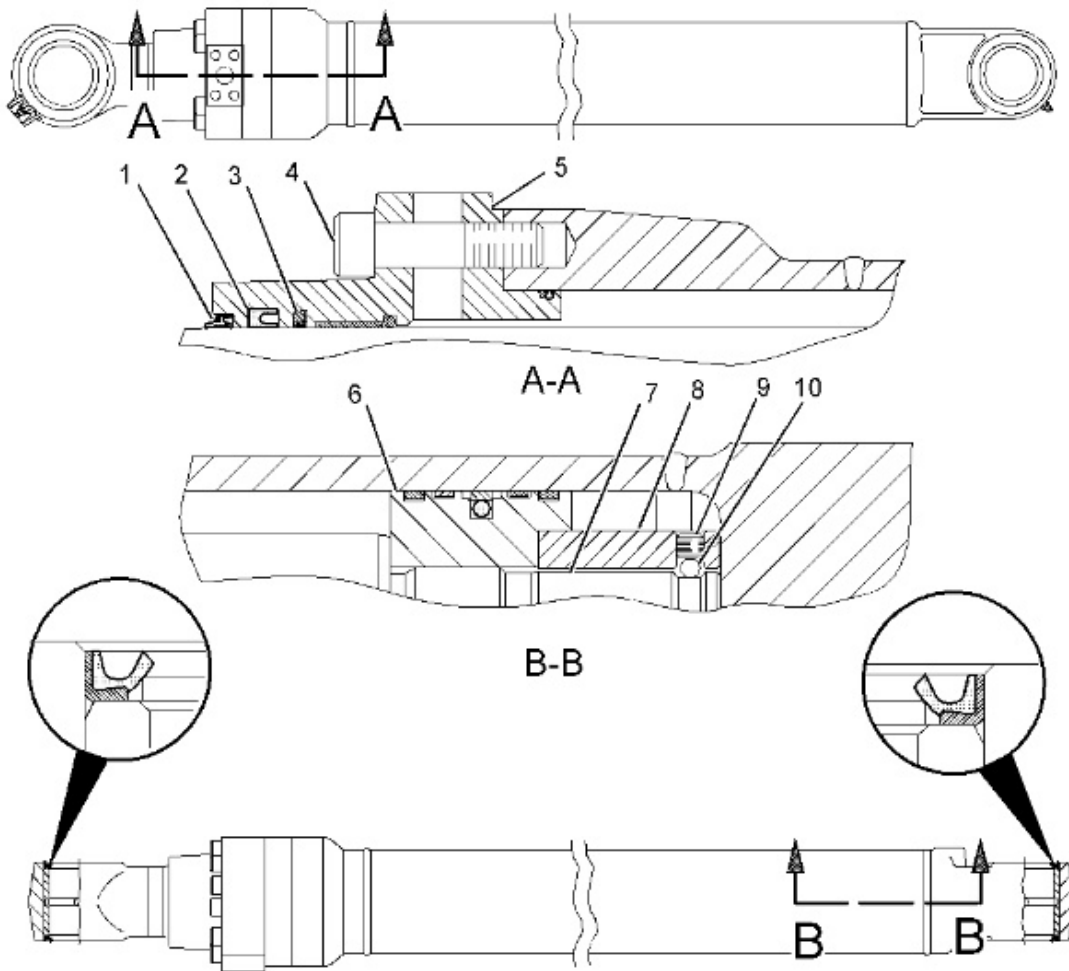

Illustration 4

g01174095

Note: Apply a light film of hydraulic oil to all components before assembly.

1. Apply Tooling (B) to seal (1) prior to assembly.
2. Apply clean hydraulic oil on the lip of seal (1), seal (2), and seal (3).
3. Apply Tooling (C) to the threads of head (5).
4. Lubricate the threads of rod assembly (7) with Tooling (C).
5. Tighten locknut (8). Refer to "Specifications" , Stick Cylinder for torque specification.
6. Install ball (10) and setscrew (9) in locknut (8). Tighten setscrew (9) to a torque of 57 ± 10 N·m (42 ± 7 lb ft).
7. Lubricate the outside of piston (6) with Tooling (C).
8. Tighten bolts (4) to a torque of 367 ± 55 N·m (271 ± 41 lb ft).

Installation Procedure

Table 2

Required Tools			
Tool	Part Number	Part Description	Qty
D	5P-0960	Grease Cartridge	1

1. Make sure that all the pin bores are free of dirt and debris prior to the installation of the stick cylinder.
2. Attach a suitable lifting device to the stick cylinder. The weight of the stick cylinder is approximately 278 kg (615 lb).

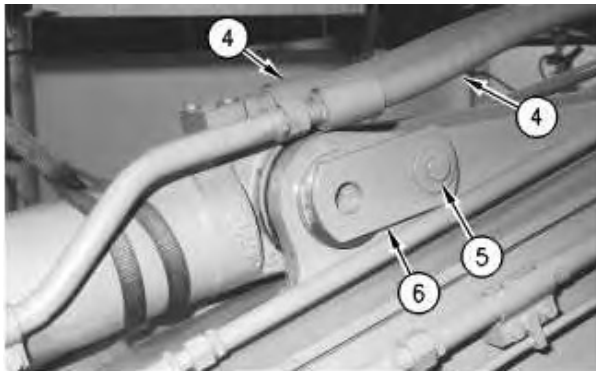

Illustration 5

g00689639

3. Place the stick cylinder in position on the stick and on the boom. Make sure that the pin bores in the stick and the pin bores in the boom align.

Note: Some machines may be equipped with shims between the stick and the stick cylinder at the pin bore.

4. Install any shims that may be required between the stick and the stick cylinder. Refer to Specifications for further information.
5. Put a thin coat of Tooling (D) on pin assembly (6). Install the spacer and pin assembly (6). Install the washer and retaining bolt (5). Tighten the remaining bolt to a torque of 460 ± 60 N·m (340 ± 44 lb ft). Do not remove the lifting device from the stick cylinder at this time.
6. Install new O-ring seals in the ends of hose assemblies (4). Connect hose assemblies (4).

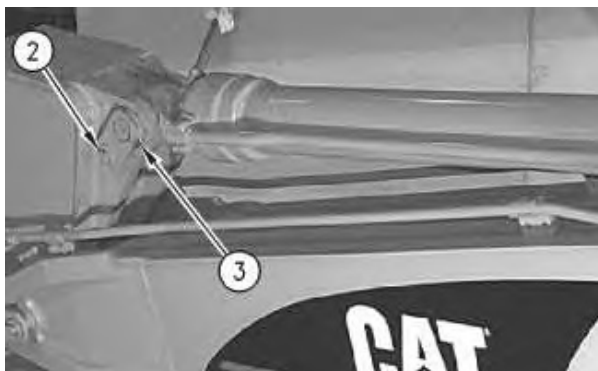

7. Align the pin bore in the rod end of the stick cylinder with the bores in the stick. Install a shim on both sides of the stick cylinder at the bore for the stick cylinder in the stick.
8. Put a thin coat of Tooling (D) on pin assembly (3). Install the spacer and pin assembly (3). Install bolt (2). Tighten the retaining bolt to a torque of $460 \pm 60 \text{ N}\cdot\text{m}$ ($340 \pm 44 \text{ lb ft}$).



Illustration 7

9. Remove the suitable lifting device from stick cylinder (1).
10. Fill the hydraulic oil tank with oil to the correct level. Refer to Operation and Maintenance Manual, "Refill Capacities".
11. Lubricate the pins for the stick cylinder.
12. Start the machine and run the machine at low idle speed. Move the control lever for the stick cylinder so that the cylinder rod extends to the halfway position. Retract the cylinder rod. The stick should be cycled in this manner for approximately ten cycles to remove any air from the hydraulic system. Recheck the oil level in the hydraulic oil tank.

[Previous Screen](#)

Product: EXCAVATOR

Model: 320C EXCAVATOR BDC

Configuration: 320C & 320C L Excavators BDC00001-UP (MACHINE) POWERED BY 3066 Engine

Disassembly and Assembly 320C Excavator Machine Systems

Media Number -REN3826-16

Publication Date -01/11/2014

Date Updated -30/03/2016

i01951483

Stick - Remove

SMCS - 6502-011

Removal Procedure

Start By:

- a. Remove the bucket. Refer to Disassembly and Assembly, "Bucket - Remove".
1. Start the machine. Fully retract the bucket cylinder. Secure the linkage to the stick.



Illustration 1

g00686746

2. Fully extend the stick cylinder. Lower the stick to the floor. Block the end of the stick that connects to the boom. Stop the engine.
-



Illustration 2

g00686722

3. Place a wood block under stick cylinder (1).

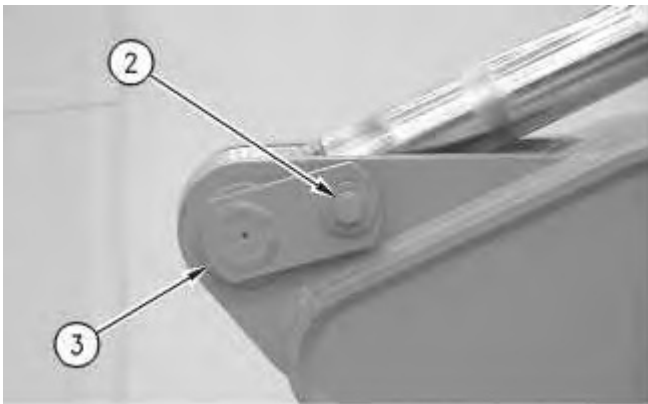

Illustration 3

g00686768

4. Remove retaining bolt (2) from pin assembly (3).

Note: Shims are located between the stick cylinder and the stick at the pin bore.

5. Remove pin assembly (3) and the spacer from the stick.
6. Start the machine. Fully retract the stick cylinder. Stop the engine.
7. Remove the shims that are located between the stick cylinder and the stick at the pin bore.



8. Position wood blocks between the stick and the boom, as shown.

NOTICE

Care must be taken to ensure that fluids are contained during performance of inspection, maintenance, testing, adjusting, and repair of the product. Be prepared to collect the fluid with suitable containers before opening any compartment or disassembling any component containing fluids.

Refer to Special Publication, NENG2500, "Dealer Service Tool Catalog" for tools and supplies suitable to collect and contain fluids on Cat[®] products.

Dispose of all fluids according to local regulations and mandates.

WARNING

At operating temperature, the hydraulic oil is hot and under pressure. Hot oils can cause burns.

To prevent possible personal injury, release the pressure in the work tool hydraulic circuit (boom, stick, bucket, and swing), travel circuits, and the hydraulic oil tank at the filler cap before any hydraulic lines or components are disconnected or removed.

Remove the filler cap only when the engine is stopped and the filler cap is cool enough to touch.

9. Release hydraulic system pressure. Refer to Disassembly and Assembly, "Hydraulic System Pressure - Release".

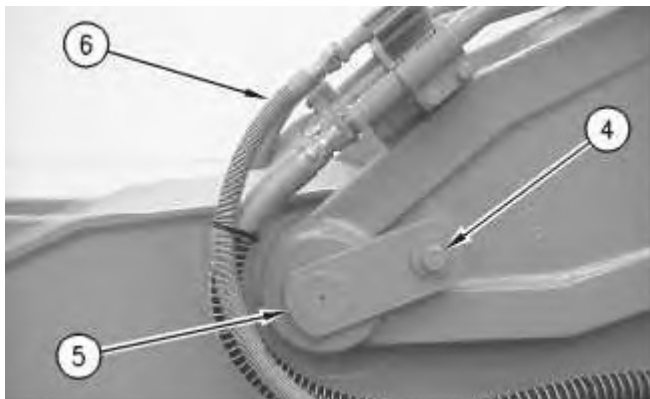

10. Remove retaining bolt (4) from pin assembly (5).

NOTICE

Keep all parts clean from contaminants.

Contamination of the hydraulic system with foreign material will reduce the service life of the hydraulic system components.

To prevent contaminants from entering the hydraulic system, always plug or cap the lines, fittings, or hoses as they are disconnected. Cover any disassembled components and clean them properly before assembly.

Clean the hydraulic system properly after any major component exchange or especially after a component failure, to remove any contamination.

Note: A hydraulic oil sample should be obtained before any maintenance is performed in order to establish the system contaminant level. Refer to Fluid Analysis Laboratory Guide, SEBF3116, "Obtaining an Oil Sample for S·O·S Analysis". Refer to Operation and Maintenance Manual, "Sampling Interval and Location of Sampling Valve" for the correct location.

11. Disconnect all hose assemblies (6).

Note: Shims are located between the boom and the stick at the pin bore.

12. Start the machine. Raise the boom away from the stick.

Note: The wood blocks that are located between the stick and the boom will fall when the boom is raised.

13. Swing the machine so that the boom may be lowered to the floor. Lower the boom to the floor. Stop the engine.
14. Remove the shims that are located between the stick and the boom at the pin bore.

[Previous Screen](#)

Product: EXCAVATOR

Model: 320C EXCAVATOR BDC

Configuration: 320C & 320C L Excavators BDC00001-UP (MACHINE) POWERED BY 3066 Engine

Disassembly and Assembly 320C Excavator Machine Systems

Media Number -REN3826-16

Publication Date -01/11/2014

Date Updated -30/03/2016

i01729819

Stick Bearings and Seals - Remove

SMCS - 6502-011-BD; 6502-011-SA

Removal Procedure

Table 1

Required Tools			
Tool	Part Number	Part Description	Qty
A	9U-5337	Bearing Puller Adapter	1
	4C-9634	Puller Stud	1
	9U-6832	Nut	1
	4K-0684	Hard Washer	1
	6V-3175	Double Acting Cylinder	1
	3S-6224	Electric Hydraulic Pump (115 Volt) ⁽¹⁾	1
	6D-7726	Hose Assembly	2
	9U-5266	Receiving Sleeve	1
B	9U-5338	Bearing Puller Adapter	1
	4C-9634	Puller Stud	1
	9U-6832	Nut	1
	4K-0684	Hard Washer	1
	6V-3175	Double Acting Cylinder	1
	3S-6224	Electric Hydraulic Pump (115 Volt) ⁽¹⁾	1
	6D-7726	Hose Assembly	2

⁽¹⁾ **8S-8033** Electric Hydraulic Pump (230 Volt) is available.

Start By:

- a. Remove the stick. Refer to Disassembly and Assembly, "Stick - Remove".

Note: For the removal of the sleeve bearings from the stick at the pin joint for the bucket control linkage, refer to Disassembly and Assembly, "Bucket Linkage Bearings and Seals - Remove".

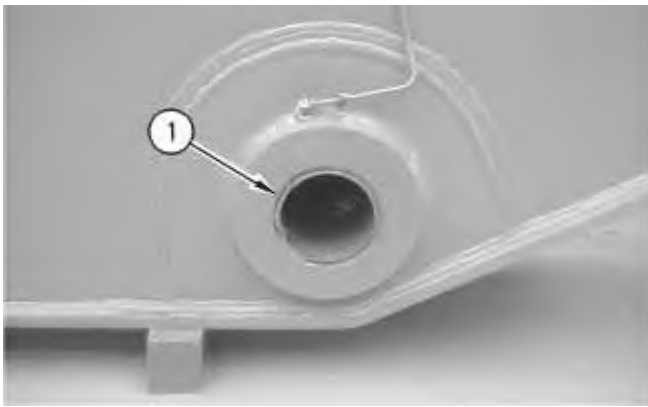

Illustration 1

g00592359

1. Remove lip type seal (1) from the bore for the boom to stick pin.

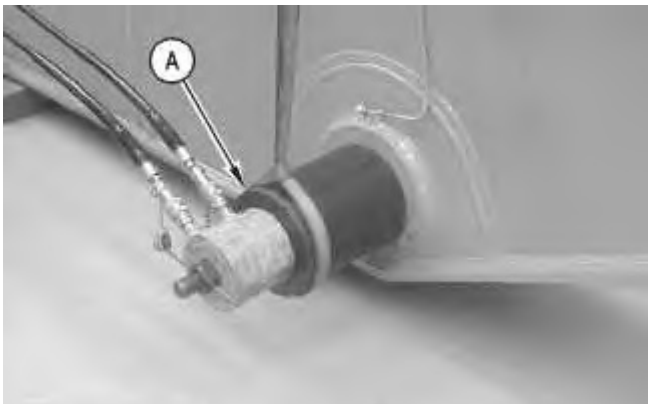

Illustration 2

g00592391

2. Use Tooling (A) to remove the sleeve bearing.
3. Repeat Steps 1 and 2 in order to remove the lip type seal and the sleeve bearing from the opposite side of the stick.

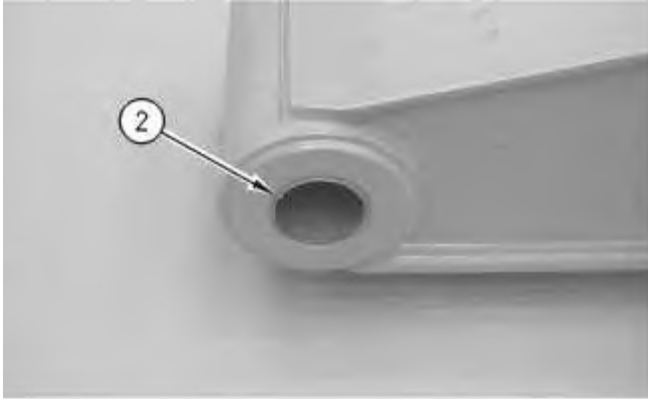

Illustration 3

g00604131

4. Remove lip type seal (2) from the bore for the stick to bucket pin.

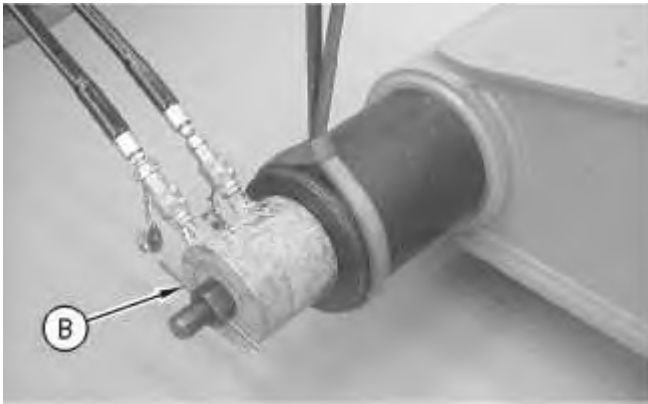

Illustration 4

g00687381

5. Use Tooling (B) to remove the sleeve bearing.
6. Repeat Steps 4 and 5 in order to remove the lip type seal and the sleeve bearing from the opposite side of the stick.

[Previous Screen](#)

Product: EXCAVATOR

Model: 320C EXCAVATOR BDC

Configuration: 320C & 320C L Excavators BDC00001-UP (MACHINE) POWERED BY 3066 Engine

Disassembly and Assembly 320C Excavator Machine Systems

Media Number -REN3826-16

Publication Date -01/11/2014

Date Updated -30/03/2016

i01946345

Stick Bearings and Seals - Install

SMCS - 6502-012-SA; 6502-012-BD

Installation Procedure

Table 1

Required Tools			
Tool	Part Number	Part Description	Qty
A	1P-0520	Driver Gp	1
B	5P-0960	Molybdenum Grease	

1. Make sure that the bores for the bearings are free of paint and grease prior to the installation of the bearings. Coat the bearings and the bearing bores with Tooling (B) prior to the installation of the bearings in the bores. Bearings must be installed with the identification numbers toward the outside of the stick.

Note: Make sure that the bearings are installed in the bore so that the identification numbers of the bearings are facing outward.

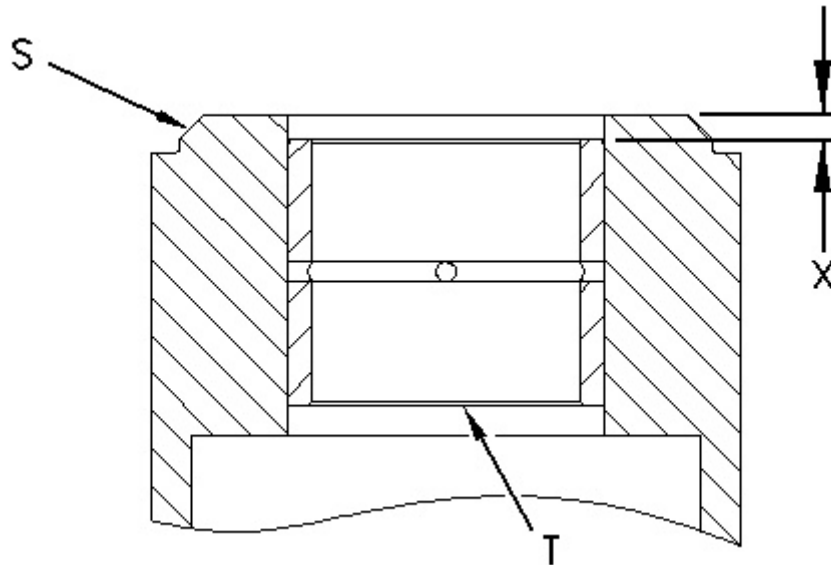

Illustration 1

g00687562

(S) Stick
(T) Sleeve Bearing

2. Lower the temperature of the sleeve bearing to $-40\text{ }^{\circ}\text{C}$ ($-40\text{ }^{\circ}\text{F}$). Use Tooling (A) to install the sleeve bearing in the bore for the stick to bucket pin. Install the sleeve bearing until Dimension (X) is $7.5 \pm 0.8\text{ mm}$ ($0.29 \pm 0.03\text{ inch}$).

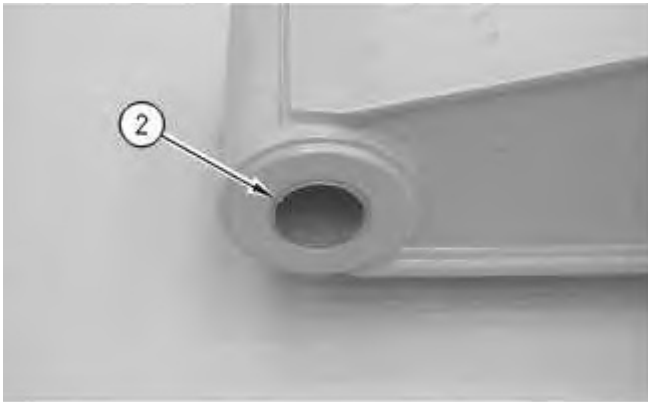

Illustration 2

g00604131

3. Use Tooling (A) to install lip seal (2) in the bore for the stick to bucket pin. Install the lip seal with the sealing lip toward the outside of the stick. Install the lip seal until the lip seal makes contact with the sleeve bearing.
 4. Repeat Steps 2 and 3 in order to install the sleeve bearing and the lip seal on the opposite side of the stick.
-

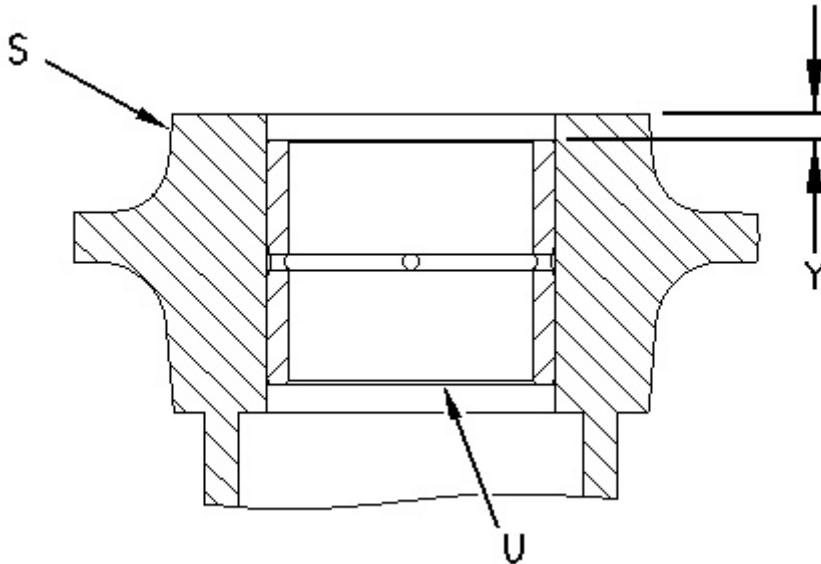

Illustration 3

g00687582

(S) Stick
(U) Sleeve Bearing

5. Lower the temperature of the sleeve bearing to $-40\text{ }^{\circ}\text{C}$ ($-40\text{ }^{\circ}\text{F}$). Use Tooling (A) to install the sleeve bearing in the bore for the stick to boom pin. Install the sleeve bearing until Dimension (Y) is $9.5 \pm 0.8\text{ mm}$ ($0.37 \pm 0.03\text{ inch}$).

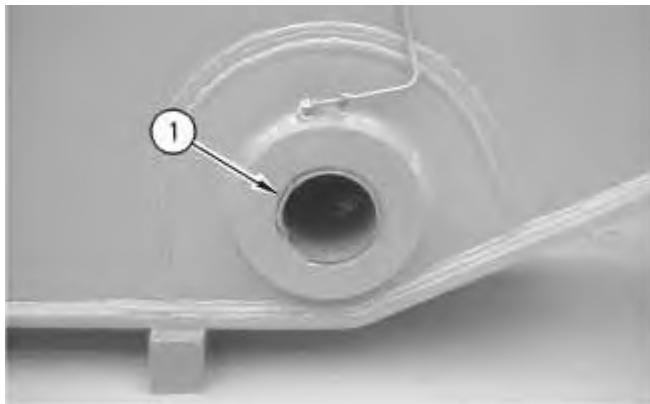

Illustration 4

g00592359

6. Use Tooling (A) to install lip seal (1) in the bore for the stick to boom pin. Install the lip seal with the sealing lip toward the outside of the stick. Install the lip seal until the lip seal makes contact with the sleeve bearing.
7. Repeat Steps 5 and 6 in order to install the sleeve bearing and the lip seal on the opposite side of the stick.
8. Put a thin coat of Tooling (B) on the sleeve bearings. Put a thin coat of Tooling (B) on the lips of the lip seals (1) and (2).

End By:

a. Install the stick. Refer to Disassembly and Assembly, "Stick - Install".

[Copyright 1993 - 2019 Caterpillar Inc.](#)

Fri Oct 11 22:51:16 UTC+0800 2019

[All Rights Reserved.](#)

[Private Network For SIS Licensees.](#)

Previous Screen

Product: EXCAVATOR

Model: 320C EXCAVATOR BDC

Configuration: 320C & 320C L Excavators BDC00001-UP (MACHINE) POWERED BY 3066 Engine

Disassembly and Assembly 320C Excavator Machine Systems

Media Number -REN3826-16

Publication Date -01/11/2014

Date Updated -30/03/2016

i01946721

Stick - Install

SMCS - 6502-012

Installation Procedure

Table 1

Required Tools			
Tool	Part Number	Part Description	Qty
A	5P-0960	Molybdenum Grease	
B	1U-6396	O-Ring Assembly Compound	

Note: Make sure that the pin bores in the stick and in the boom are thoroughly clean and free of dirt and debris prior to the installation of the stick on the boom.

1. Put a thin coat of Tooling (A) on the sleeve bearings. Put a thin coat of Tooling (A) on the lips of lip type seals.

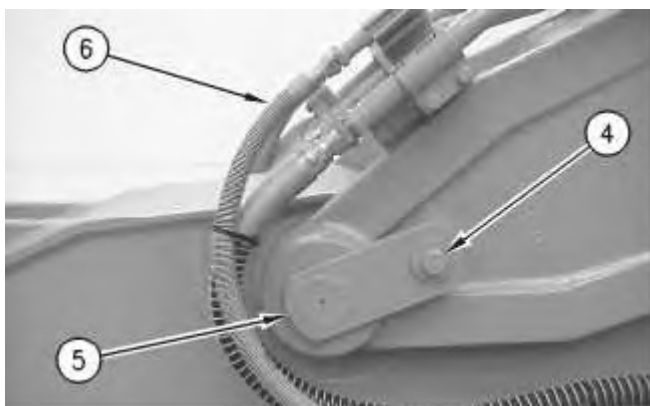

Illustration 1

g00687835

2. Start the machine. Raise the boom. Swing the boom over the stick. Align the pin bores for the boom to stick pin.
3. Install a shim (7) on each side of the boom between the boom and the stick at the pin bore. Shim (7) is identified by the tab on the shim.
4. Temporarily install pin assembly (5).

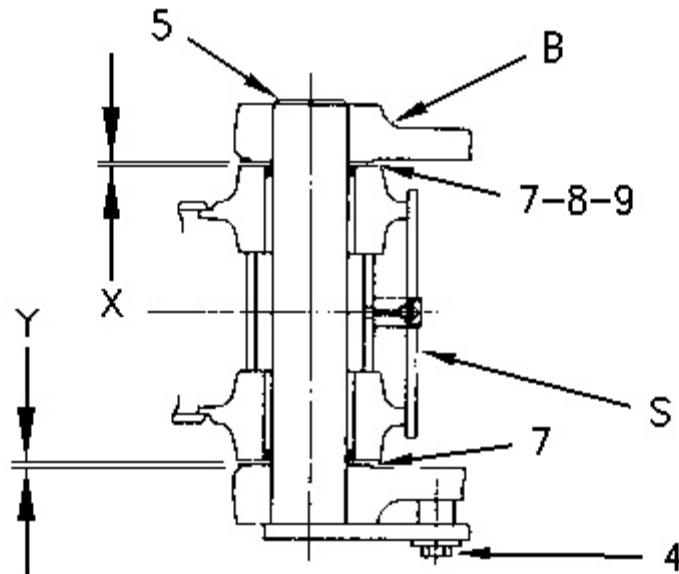

Illustration 2

g00687906

(B) Boom
(S) Stick

5. Measure the total clearance between the stick and the boom at the pin bore. The total clearance is Dimension (X) plus Dimension (Y). The total clearance must not be more than 0.8 mm (0.03 inch). If the total clearance is less than 0.8 mm (0.03 inch), the addition of shims will not be necessary. If the total clearance is more than 0.8 mm (0.03 inch), the addition of shims will be required.
6. If shims are required, remove pin assembly (5). Install the required amount of shims (8) and (9) between the stick and the boom on the side opposite retaining bolt (4). Locate shims (8) and (9) between the boom and shim (7). Install pin assembly (5).
7. Install bolt (4).

NOTICE

Care must be taken to ensure that fluids are contained during performance of inspection, maintenance, testing, adjusting, and repair of the product. Be prepared to collect the fluid with suitable containers before opening any compartment or disassembling any component containing fluids.

Refer to Special Publication, NENG2500, "Dealer Service Tool Catalog" for tools and supplies suitable to collect and contain fluids on Cat[®] products.

Dispose of all fluids according to local regulations and mandates.

 **WARNING**

At operating temperature, the hydraulic oil is hot and under pressure. Hot oils can cause burns.

To prevent possible personal injury, release the pressure in the work tool hydraulic circuit (boom, stick, bucket, and swing), travel circuits, and the hydraulic oil tank at the filler cap before any hydraulic lines or components are disconnected or removed.

Remove the filler cap only when the engine is stopped and the filler cap is cool enough to touch.

8. Release the hydraulic system pressure. Refer to Disassembly and Assembly, "Hydraulic System Pressure - Release".

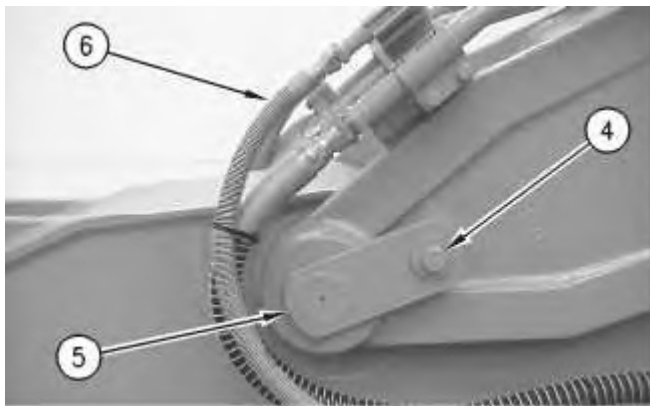

Illustration 3

g00687835

Note: O-ring seals, gaskets and seals should always be replaced. A used O-ring seal may not have the same sealing properties as a new O-ring seal. A reconditioning procedure should not be degraded because of a low cost component such as an O-ring seal or a gasket. Use Tooling (B) during the assembly procedure.

9. Install new O-ring seals in the ends of all hose assemblies. Connect hose assemblies (6).
-



Suggest:

If the above button click is invalid.

Please download this document

first, and then click the above link

to download the complete manual.

Thank you so much for reading

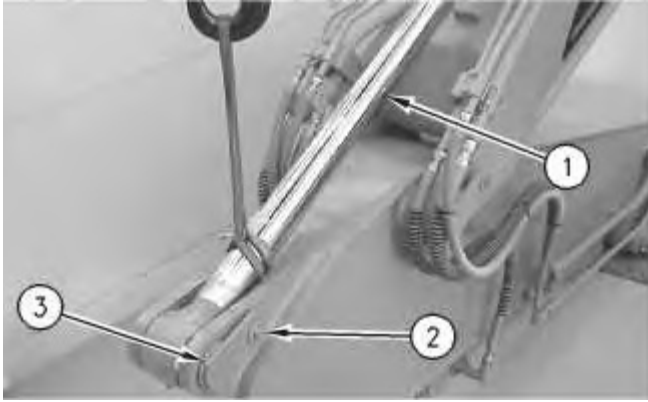

Illustration 4

g00687890

10. Fasten a lifting sling to the rod end of stick cylinder (1). Extend stick cylinder (1) until the pin bore lines up with the pin bores in the stick. Install a shim on each side of the stick cylinder at the pin bore.
11. Install the spacer and pin assembly (3). Install bolt (2).
12. Remove the suitable lifting device. Remove the wood block between the stick cylinder and the boom.
13. Install high efficiency filters in place of the pilot filter, the case drain filter, and the return filter.

Note: High efficiency filters should not be run for more than 250 hours before you change back to the standard filters.

14. Obtain a hydraulic oil sample from the main S·O·S port.

Reference: Refer to Operation and Maintenance Manual, "Sampling Interval and Location of Sampling Valve" for the correct location.

15. If the S·O·S sample exceeds ISO 18/15, flush the hydraulic system.

Reference: Refer to Contamination Control Guidelines, SEBF8436, "Hydraulic System Flushing Procedure for 320C Hydraulic Excavators" for further information.

<https://www.ebooklibonline.com>

Hello dear friend!

Thank you very much for reading.

Enter the link into your browser.

The full manual is available for immediate download.

<https://www.ebooklibonline.com>