



Service Repair Manual

Model

320B EXCAVATOR

[Previous Screen](#)

Product: EXCAVATOR

Model: 320B EXCAVATOR 8ES

Configuration: SUPPLEMENTARY SERVICE INFORMATION (DISASSEMBLY & ASSEMBLY) F 8ES00001-UP (MACHINE)

Disassembly and Assembly

320B, 320B L, 320B LN, 320B N, & 320B S EXCAVATORS MACHINE SY

Media Number -SEN9257-06

Publication Date -01/04/2004

Date Updated -18/01/2017

SEN92570016

Track Carrier Rollers

SMCS - 4154-010; 4154-017

Remove & Install Track Carrier Rollers

Tools Needed	A
8T-5255 Hydraulic Jack	1

1. Put the machine on a flat level floor.



The grease in the track adjusting cylinder is under high pressure. Grease coming out of the relief valve of the track adjuster, which is under high pressure, can penetrate the body causing personal injury or death. When loosening the tension on the track, loosen the relief valve only one turn. Do Not visually inspect the relief valve to see if grease is being released from the track adjuster. Instead, watch the track to see if it loosens, if the track does not loosen after opening the relief valve, move the machine forward and backward to release the tension.

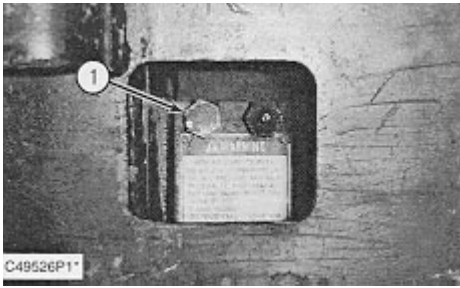

2. Release the tension on the track. Loosen relief valve (1) only one turn. If the track does not loosen after opening the relief valve, move the machine forward and backward until the tension is released.

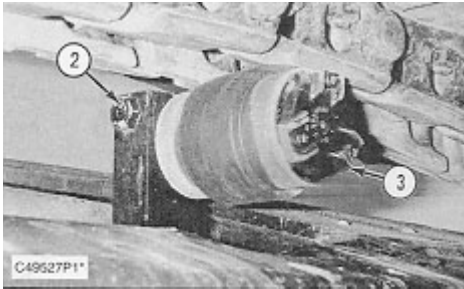

3. Loosen bolt (2) that holds track carrier roller (3) to the mounting bracket on the undercarriage frame assembly.

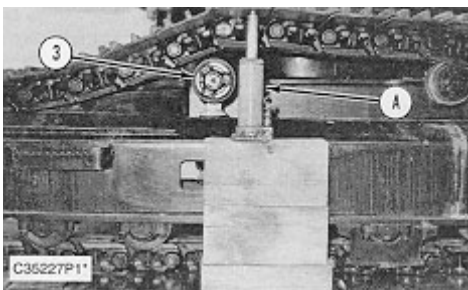

4. Put wood blocks and Tool (A) under the track assembly, as shown. Lift the track assembly off of the track carrier roller. Using two persons, remove track carrier roller (3). The weight of the track carrier roller is **23 kg (50 lb)**.

NOTE: The following steps are for the installation of the track carrier roller.

5. Be sure the shaft of the track carrier roller and the bore in the mounting bracket on the undercarriage frame assembly is clean and free of dirt.

<https://www.ebooklibonline.com>

Hello dear friend!

Thank you very much for reading.

Enter the link into your browser.

The full manual is available for immediate download.

<https://www.ebooklibonline.com>

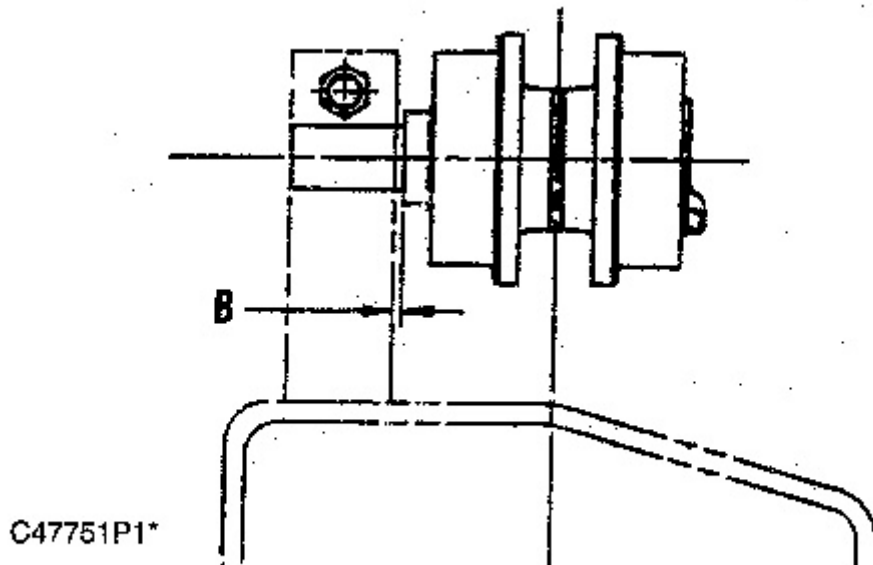

6. Put the track carrier roller in position in the mounting bracket. Adjust the carrier roller until distance (B), the distance between the outside face of the mounting bracket and the carrier roller is **7.0 ± 0.5 mm (.28 ± .02 in)**.
7. After adjusting the position of the carrier roller in the mounting bracket, tighten bolt (2). Torque to $460 \pm 60 \text{ N}\cdot\text{m}$ ($340 \pm 44 \text{ lb ft}$).
8. Be sure the carrier roller rotates smoothly by hand. Slowly lower the track assembly on to the carrier roller with Tool (A).
9. Tighten the tension of the track. Refer to the topic "Tracks" in the "Operation & Maintenance Manual."

Disassemble & Assemble Track Carrier Rollers

Tools Needed		A	B	C
1P-0510	Driver Group	1		
9U-5985	Seal Installer		1	
8T-5096	Dial Indicator Group			1

Start By:

- a. remove track carrier rollers

Fluid Spillage Containment

Care must be taken to ensure that the fluids are contained during performance of the inspection, the maintenance, the testing, the adjusting and the repair of the machine. Be prepared to collect the fluid with suitable containers before opening any compartment or disassembling any component

containing fluids. Refer to the "Tools And Shop Products Guide, NENG2500" the tools and the supplies suitable to collect and contain any of the fluids in Caterpillar machines. Dispose of the fluids according to local regulations and mandates.

1. Thoroughly clean the outside of the track carrier roller prior to disassembly.

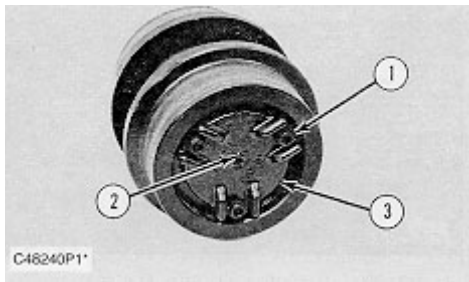

2. Remove plug (2), and drain the oil from the carrier roller in a suitable container for disposal. The capacity of the track carrier roller is **120 ± 5 ml (4.08 ± 0.17 oz)**.

3. Remove three socket head bolts (1) and cover (3) from the track carrier roller.

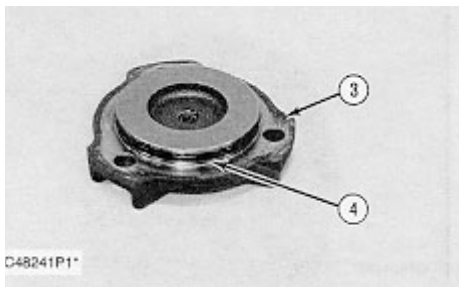

4. Remove O-ring seal (4) from cover (3).

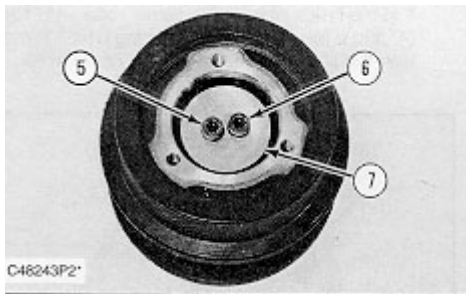

5. Remove socket head bolts (5) and (6) and retainer (7) from the end of the shaft assembly.

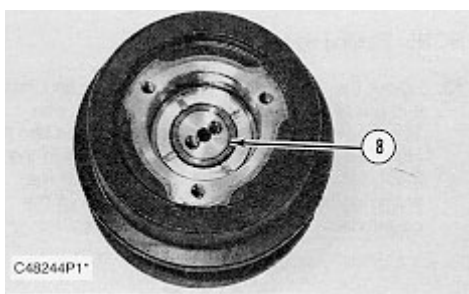

6. Carefully remove shaft assembly (8) from the track carrier roller.

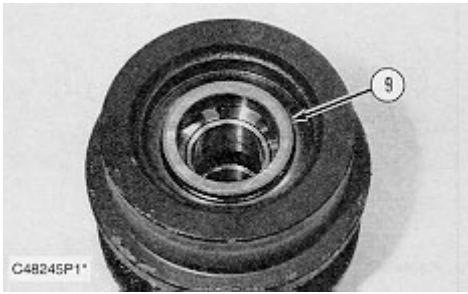

7. Remove Duo-Cone seal (9) from the track carrier roller.

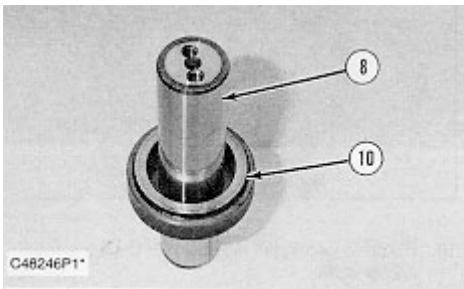

8. Remove Duo-Cone seal (10) from the shaft assembly (8).

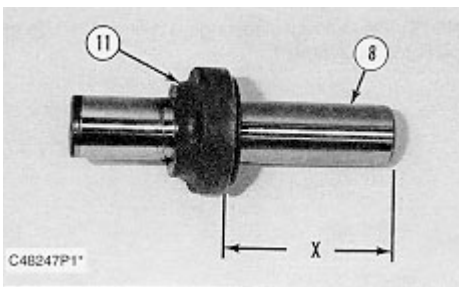

9. Measure distance (X) on the shaft assembly. Record this dimension for assembly purposes. Using a press, push shaft (8) out of collar (11). Remove the O-ring seal from inside the collar.

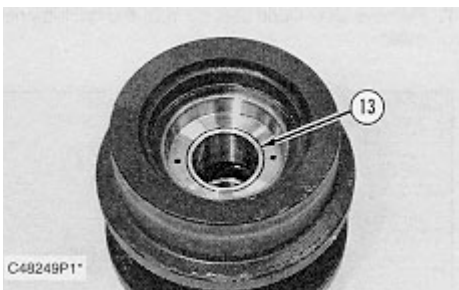
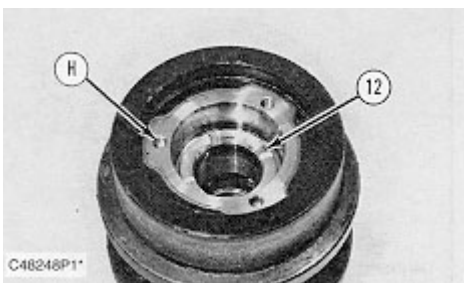

10. Remove bearings (12) and (13) from the track carrier roller.

NOTE: The following steps are for the assembly of the track carrier rollers.

11. Thoroughly clean all parts of the track carrier roller prior to assembly.

NOTE: Do Not reuse bearings (12) and (13). Use new parts for replacement.

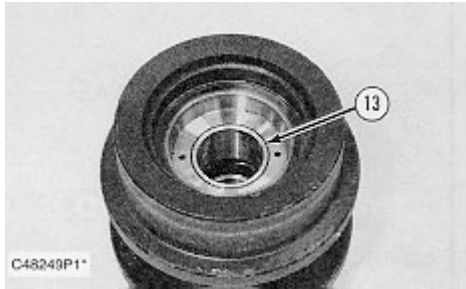

NOTE: Bearing (13) is a straight bearing.

12. Lower the temperature of bearing (13), and install it in the inside bore of the carrier roller with Tooling (A) and a press. Install the bearing until it is even with the shaft counterbore in the carrier roller.

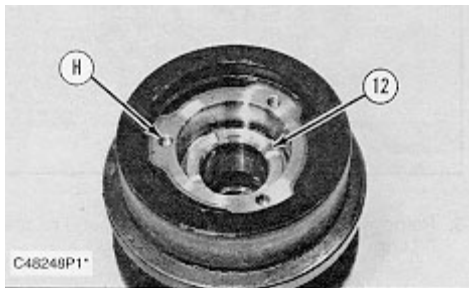

NOTE: Bearing (12) has a flange on it.

13. Lower the temperature of bearing (12), and install it in the outside bore of the carrier roller with Tooling (A) and a press. The outside bore can be identified by the three threaded holes (H) in the track carrier roller. Install the bearing until the flange on the bearing makes contact with the counterbore in the track carrier roller.

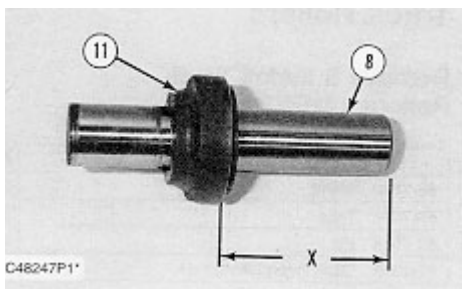

14. Check the condition of the O-ring seal used in collar (11). If the O-ring seal is damaged, use a new part for replacement. Install the O-ring seal in the collar. Put clean oil on the O-ring seal.

15. Using a press, install collar (11) on shaft (8) until dimension (X) is **129.2 ± 0.2 mm (5.09 ± .008 in)**.

16. Determine shaft end play as follows:

NOTE: Do Not install the Duo-Cone seals in the track carrier roller or collar (11) at this time.

- a. Install shaft assembly (8) in the track carrier roller without Duo-Cone seals.
- b. Install retainer (7) and socket head bolts (5) and (6) on the end of shaft assembly (8).
- c. Use Tooling (C) to measure the end play of shaft assembly (8). The end play of the shaft assembly must be **0.20 to 0.75 mm (.008 to .030 in)**. Bearing (12) controls the amount of shaft end play.
- d. Disassemble the track carrier roller, but **Do Not** remove collar (11) from shaft (8).

NOTICE

Refer to the topic "Assembly And Installation Of Conventional Duo-Cone Seals" in this module.

NOTE: The rubber seal and all of the surfaces that make contact with the seals must be clean and dry. After the installation of the seals, apply clean SAE 30 oil on the contact surfaces of the metal seals.

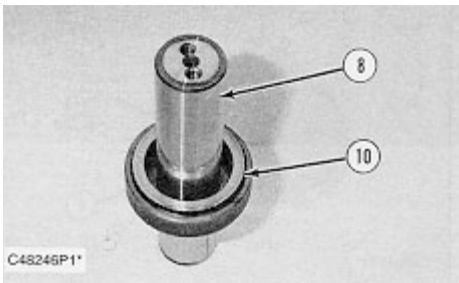

17. Install Duo-Cone seal (10) in collar (11) with Tool (B).

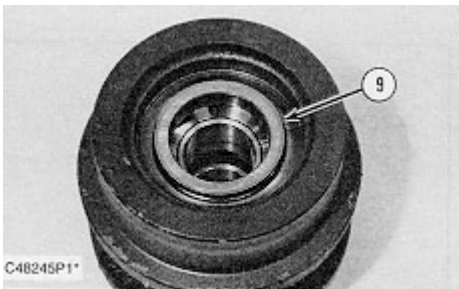

18. Install Duo-Cone seal (9) in the track carrier roller (side without three threaded holes) with Tool (B).

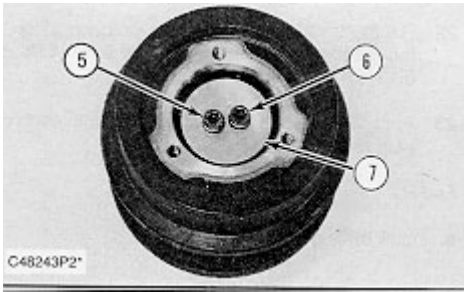

19. Carefully install shaft assembly (8) in the track carrier roller. Install retainer (7) and socket head bolts (5) and (6).

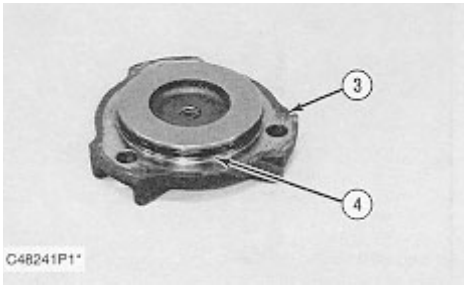

20. Check the condition of O-ring seal (4) used on cover (3). If the O-ring seal is damaged, use a new part for replacement. Put clean oil on O-ring seal (4), and install it on cover (3).

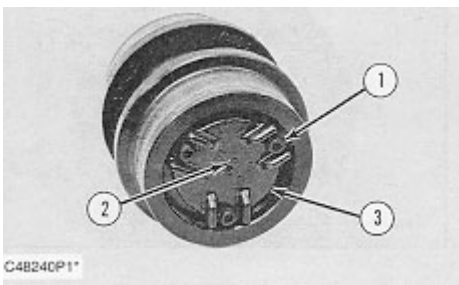

21. Install cover (3) on the track carrier roller and three socket head bolts (1) that hold it.

22. Put the track carrier roller in a vertical position. Fill the track carrier roller with **120 ± 5 ml (4.08 ± 0.17 oz)** of clean SAE 30 oil.

23. Apply **5P-3413 Pipe Sealant** on the threads of plug (2). Install plug (2).

End By:

a. install track carrier rollers

[Previous Screen](#)

Product: EXCAVATOR

Model: 320B EXCAVATOR 8ES

Configuration: SUPPLEMENTARY SERVICE INFORMATION (DISASSEMBLY & ASSEMBLY) F 8ES00001-UP (MACHINE)

Disassembly and Assembly

320B, 320B L, 320B LN, 320B N, & 320B S EXCAVATORS MACHINE SY

Media Number -SEN9257-06

Publication Date -01/04/2004

Date Updated -18/01/2017

SENR92570017

Track Rollers

SMCS - 4180-010; 4180-017

Remove & Install Track Rollers

Tools Needed		A	B
8S-7640	Stand	2	
8S-7611	Tube	2	
8S-7615	Pin	2	
FT-1310	Track Roller Lifting Fork		1

NOTE: There is a track guide on each side of the machine. The procedure which follows is for the removal and the installation of the track roller with the guide.

1. Put the machine on a flat level floor.



WARNING

The grease in the track adjusting cylinder is under high pressure. Grease coming out of the relief valve of the track adjuster, which is under high pressure, can penetrate the body causing personal injury or death. When loosening the tension on the track, loosen the relief valve only one turn. Do Not visually inspect the relief valve to see if grease is being released from the track adjuster. Instead, watch the track to see if it loosens, if the track does not loosen after opening the relief valve, move the machine forward and backward to release the tension.

2. Release the tension on the track. Loosen the relief valve for the track adjuster only one turn. If the track does not loosen after opening the relief valve, move the machine forward and backward until the tension is released.

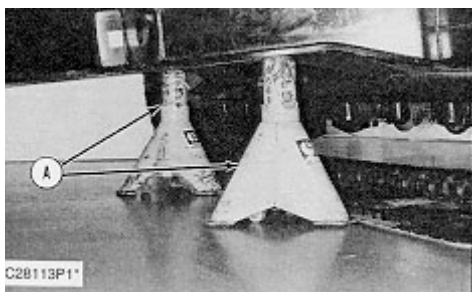

NOTE: Adjust height of Tooling (A) so when it is installed under the frame of the machine, there is enough clearance provided for the removal of any one of the track rollers.

3. Lift the side of the machine, and install Tooling (A) under the frame, as shown.

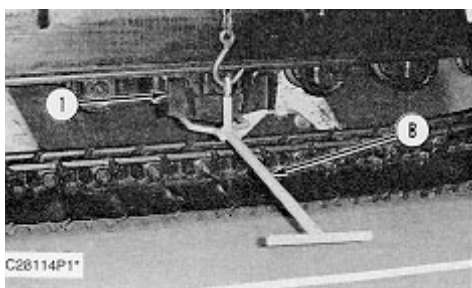

4. Loosen the four bolts that hold track guide (1) to the undercarriage frame assembly. **Do Not** remove the bolts at this time.

5. Fasten a hoist on Tool (B), and put in position under track guide (1), as shown. Remove the bolts that hold the guide; then remove the guide.

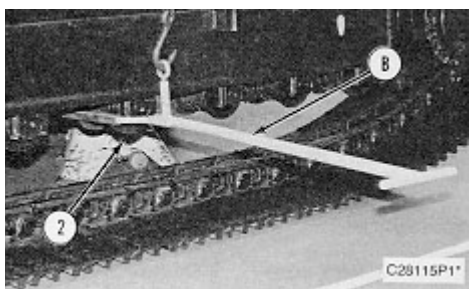

NOTE: The fork end of Tool (B) is slightly wider than the diameter of the track roller. Prior to using Tool (B) for the removal of the track roller, slide two pieces of rubber hose over the fork end of the tool. This will reduce the spacing of the fork, and provide the necessary fit around the track roller.

6. Loosen the four bolts that hold track roller (2) to the undercarriage frame assembly. **Do Not** remove the bolts at this time.

7. Fasten a hoist to Tool (B), and put it in position under track roller (2), as shown. Remove the bolts that hold the track roller; then remove the track roller. The weight of the track roller is **29 kg (65 lb)**.

NOTE: The following steps are for the installation of the track roller.

8. Be sure the mounting surfaces on the track roller, the guide and the undercarriage frame assembly are clean and free of dirt and debris prior to the installation of the track roller and the guide.
9. Put track roller (2) in position on the undercarriage frame assembly with Tool (B). Be sure the fill plug on the roller is facing out. Install the four bolts that hold the roller in position.
10. Put track guide (1) in position on the undercarriage frame assembly with Tool (B). Install the four bolts that hold the guide.
11. Prior to lowering the machine to the ground and tightening the track, be sure all of the track rollers rotate smoothly by hand.
12. Lift the machine off of Tooling (A), and remove the stands from under the machine. Lower the machine to the floor.
13. Tighten the tension of the track. Refer to the topic "Tracks" in the "Operation & Maintenance Manual".

Disassemble & Assemble Track Rollers

Tools Needed		A	B
1U-8841	Seal Installer	1	
8T-5096	Dial Indicator Group		1

Start By:

a. remove track rollers

1. Thoroughly clean the outside of the track roller prior to disassembly.

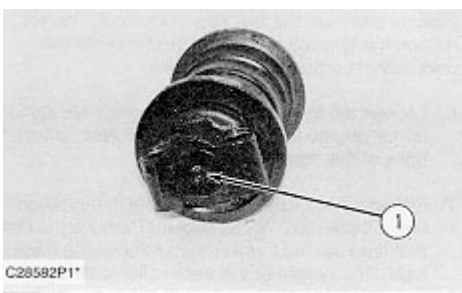

2. Drive plug (1) into the stopper in the end of the track roller, and drain the oil from the track roller in a suitable container. The capacity of the track roller is **225 ± 15 ml (7.65 ± .51 oz)**.

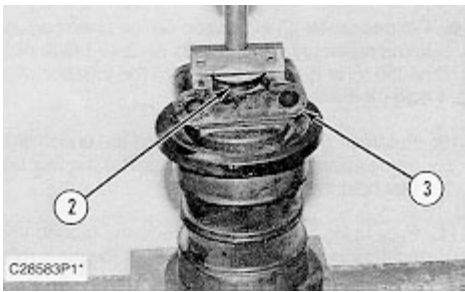

3. Put the track roller in a press, as shown. The weight of the track roller is **approximately 29 kg (65 lb)**. Press down on end collar (3), and remove snap ring (2). Release the pressure on the end collar. Remove end collar (3).

4. Remove plug (1) from inside the track roller.

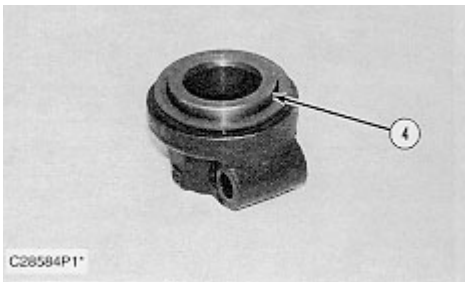

5. Remove Duo-Cone seal (4) from end collar (3).

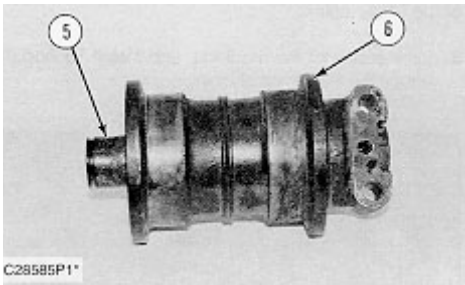

6. Remove the O-ring seal from shaft (5); then remove shaft (5) from roller (6).

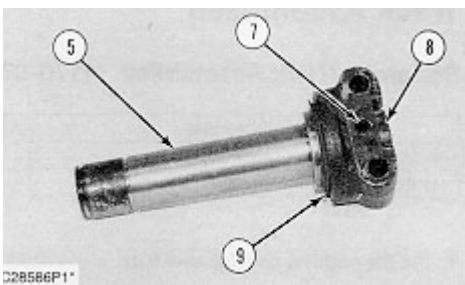

7. Remove Duo-Cone seal (9) from end collar (8).

8. Remove spring pin (7) from end collar (8) and shaft (5). Using a press, remove shaft (5) from end collar (8). Remove the remaining O-ring seal from shaft (5).

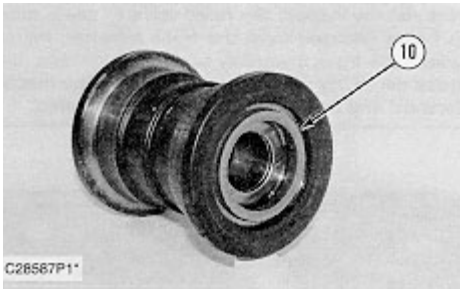

9. Remove Duo-Cone seal (10) from each end of the track roller.

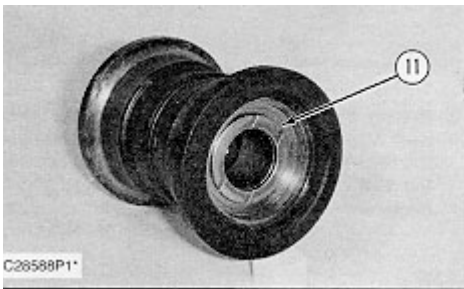

10. Remove bearing (11) from each end of the track roller with a press.

NOTE: The following steps are for the assembly of the track roller.

11. Thoroughly clean all parts of the track roller prior to assembly.

NOTE: Do Not re-use bearings (11). Use new parts for replacement.

12. Check the condition of the two O-ring seals used on shaft (5). If the O-ring seals are worn or damaged, use new parts for replacement.

13. Lower the temperature of bearings (11), and install one in each end of the track roller with a press. Install the bearings until they make contact with the counterbore in the track roller.

14. Determine shaft end play as follows:

NOTE: Do Not install the Duo-Cone seals in the track roller or the end collars at this time.

a. Install an O-ring seal in shaft (5) at the end that has the spring pin hole. Lubricate the O-ring seal with clean oil.

b. Lubricate the bore in end collar (8) with clean oil. Using a press, install shaft (5) in end collar (8). Be sure the spring pin hole in the shaft is in alignment with the spring pin hole in the end collar. Install spring pin (7) in the end collar and shaft.

c. Install shaft (5) in track roller (6) without the Duo-Cone seals. Install end collar (3) without the Duo-Cone seals; then install snap ring (2).

d. Use Tooling (B) to measure the end play of shaft (5). The end play of the shaft must be **0.25 to 1.25 mm (.0098 to 0.0492 in)**. Bearings (11) control the amount of shaft end play.

e. Disassemble the track roller, but **Do Not** remove shaft (5) from end collar (8).

NOTICE

Refer to the topic "Assembly And Installation Of Conventional Duo-Cone Seals" in this module.

NOTE: The rubber seals and all of the surfaces that make contact with the seals must be clean and dry. After the installation of the seals, put clean SAE 30 oil on the contact surfaces of the metal seals.

15. Install a Duo-Cone seal (10) in each end of the track roller with Tool (A).
 16. Install Duo-Cone seal (9) in end collar (8) with Tool (A).
 17. Install Duo-Cone seal (4) in end collar (3) with Tool (A).
-

NOTICE

Do Not damage the Duo-Cone seals during the installation of the shaft in the track roller or the installation of end collar (3).

18. Install shaft (5) with end collar (8) in track roller (6).
19. Install the O-ring seal in the groove on the end of shaft (5). Lubricate the O-ring seal with clean oil.
20. Lubricate the bore in end collar (3) with clean oil.
21. Put the track roller in a press. Install end collar (3) on the end of shaft (5). Push down on end collar (3) with the press, and install snap ring (2).
22. Check the track roller for air leaks. Apply **250 to 270 kPa (36 to 39 psi)** of air pressure to the roller for a minimum of **30 seconds**. If the pressure gauge reading does not change in a **30 second time period**, it can be assumed there are no leaks in the roller.
23. Put the track roller in a vertical position. Fill the track roller with **225 ml (7.65 oz)** of the type oil specified in the "Operation & Maintenance Manual". Install a new plug (1) in the stopper in the end of the track roller.

End By:

- a. install track rollers
-

Previous Screen

Product: EXCAVATOR

Model: 320B EXCAVATOR 8ES

Configuration: SUPPLEMENTARY SERVICE INFORMATION (DISASSEMBLY & ASSEMBLY) F 8ES00001-UP (MACHINE)

Disassembly and Assembly

320B, 320B L, 320B LN, 320B N, & 320B S EXCAVATORS MACHINE SY

Media Number -SEN9257-06

Publication Date -01/04/2004

Date Updated -18/01/2017

SEN92570018

Track Assemblies

SMCS - 4170-076; 4170-077

Separate Track Assemblies

Tools Needed		A	B
5P-6214	Track Block Assembly	1	
1U-7630	Socket		1

1. Put the machine on a flat level floor.



WARNING

The grease in the track adjusting cylinder is under high pressure. Grease coming out of the relief valve of the track adjuster, which is under high pressure, can penetrate the body causing personal injury or death. When loosening the tension on the track, loosen the relief valve only one turn. Do Not visually inspect the relief valve to see if grease is being released from the track adjuster. Instead, watch the track to see if it loosens, if the track does not loosen after opening the relief valve, move the machine forward and backward to release the tension.

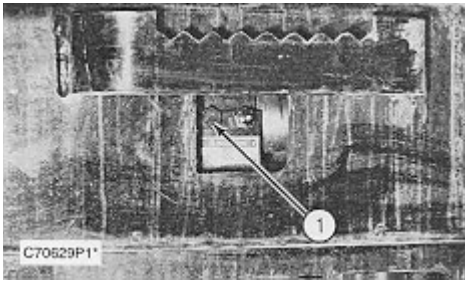

2. Release the tension on the track assembly. Loosen relief valve (1) for the track adjuster only one turn. If the track assembly does not loosen after opening the relief valve, move the machine forward and backward until the tension is released.

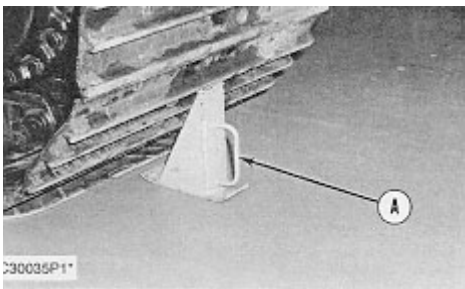
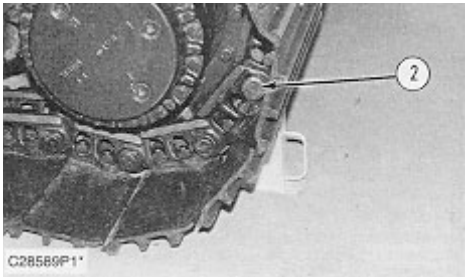

NOTE: To provide additional clearance for the removal of the master pin, the track shoe on each side of the master pin can be removed. Use Tool (B) to remove the track shoe mounting bolts.

3. Move the track assembly until master pin (2) is in the approximate position shown. Put Tool (A) under the track grouser as shown, and move the track on the tool.



WARNING

To prevent possible personal injury during the removal of the master pin, keep away from the area outside the track assembly near the master pin. The master pin may come out of the track links with force during the removal procedure.

NOTE: The track bushings will fall out of the track links when the track assembly is separated.

4. Remove cotter pin (3) from the master pin. Use a hammer and punch to remove master pin (2) from the track links. Separate the track links, and locate the two track bushings. Move the machine slowly forward to move the track assembly off of the sprocket, the track carrier rollers and the front idler.

5. Fasten a hoist to the rear of the track assembly. Raise the track assembly off of Tool (A), and remove the tool from under the track assembly. Lower the rear of the track assembly to the floor.

Connect Track Assemblies

Tools Needed		A	B	C	D	E
1P-3545	Chain Coupling Tool Group	1				
1P-3533	Carrier Bar		1			
1P-7402	Coupling Tool Group			1		
5P-6214	Track Block Assembly				1	
1U-7630	Socket					1

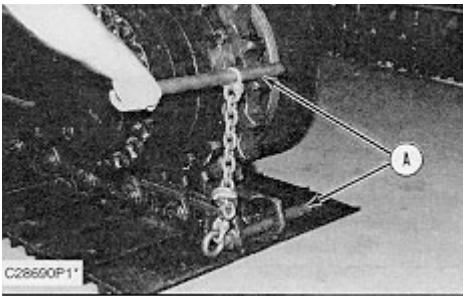

1. Install Tooling (A) in the track link and on the sprocket as shown.

2. Start the machine. Move the sprocket forward until the track assembly is pulled up on the sprocket and the end of the track assembly is forward of a vertical line through the center of the sprocket. Remove Tooling (A).

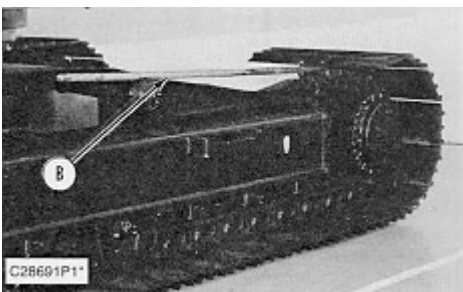

3. Install Tool (B) between the first bushing in the track link and the sprocket as shown.

4. Move the sprocket forward. Use Tool (B) to guide the track assembly over the carrier rollers and the front idler.

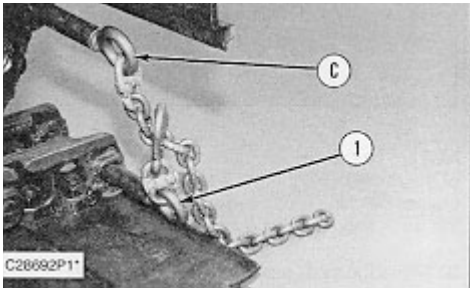

5. Install Tooling (C) and pin (1) from Tooling (A) between the links in the ends of the track assembly as shown.

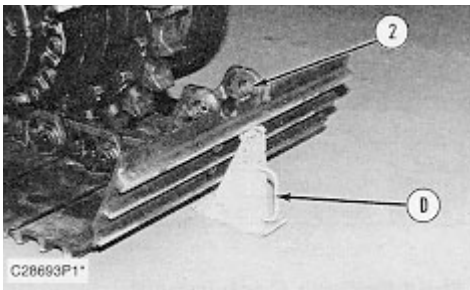

6. Move the track assembly forward or backward until the separation in the track assembly is below a horizontal line through the center of the sprocket.

7. Apply **5P-0960 Multipurpose Grease** on two track bushes (2), and install them in the track links as shown. The grease will hold the bushes in place.

8. Install Tool (D) under the rear of the track assembly as shown. Move the track assembly backwards until the separation in the track assembly closes and the pin bores in both ends of the track assembly are in alignment with each other. The machine may have to be moved back and forth to align the pin bores.

9. Apply **5P-0960 Multipurpose Grease** in the master pin bores in the track assembly and on the master pin. Install the master pin with a hammer. Install the cotter pin to retain the master pin. Remove Tool (D) from under the rear of the track assembly.

10. If the track shoe on each side of the master pin was removed, reinstall them. Use Tool (E) to reinstall the track shoe mounting bolts.

11. Tighten the tension of the track. Refer to the topic "Tracks" in the "Operation & Maintenance Manual".

Previous Screen

Product: EXCAVATOR

Model: 320B EXCAVATOR 8ES

Configuration: SUPPLEMENTARY SERVICE INFORMATION (DISASSEMBLY & ASSEMBLY) F 8ES00001-UP (MACHINE)

Disassembly and Assembly

320B, 320B L, 320B LN, 320B N, & 320B S EXCAVATORS MACHINE SY

Media Number -SEN9257-06

Publication Date -01/04/2004

Date Updated -18/01/2017

SEN92570019

Front Idlers, Recoil Springs & Hydraulic Track Adjusters

SMCS - 4157-010; 4158; 4159

Remove & Install Front Idlers, Recoil Springs & Hydraulic Track Adjusters

Tools Needed	A
138-7573 Link Bracket	1

Start By:

- a. separate track assemblies

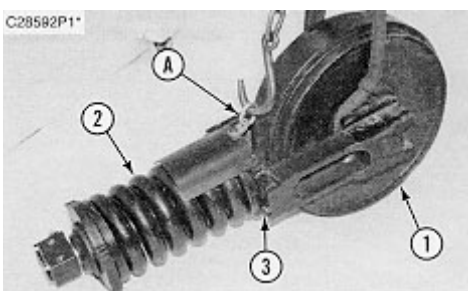
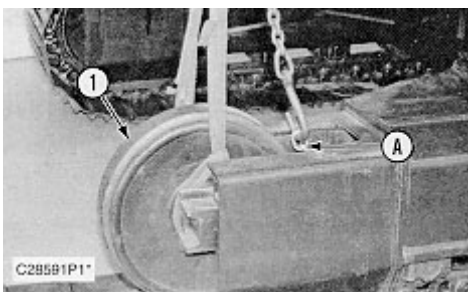

1. Remove one of the mounting bolts that hold the cover over the front of the recoil spring assembly. Fasten Tool (A) to the front support for the recoil spring, as shown. Use the cover mounting bolt hole to fasten Tool (A) in place.

2. Fasten a hoist to front idler (1) and Tool (A), as shown.

3. Slide front idler (1), the recoil spring and the hydraulic track adjuster (2) out of the under carriage frame assembly as a unit. The weight of the unit is **204 kg (450 lb)**.

4. Remove four bolts (3) that hold the front idler to the front support for the recoil spring. Separate the front idler from the recoil spring and the hydraulic track adjuster. The weight of the front idler is **109 kg (240 lb)**. The weight of the recoil spring and the hydraulic track adjuster as a unit is **95 kg (210 lb)**.

NOTE: The following steps are for the installation of the front idlers, the recoil springs and the hydraulic track adjusters.

5. Be sure the mating surfaces on the front support for the recoil spring and the two bearings for the front idler are clean and free of dirt and debris prior to reassembly.

6. Fasten a hoist to the recoil spring and the hydraulic track adjuster. Put the unit in position on the front idler. Temporarily install four bolts (3) that hold the unit together.

7. Install Tool (A) on the front support for the recoil spring. Fasten a hoist to the front idler and Tool (A).

8. Slide the front idler, the recoil spring and the hydraulic track adjuster partially into the undercarriage frame assembly leaving bolts (3) exposed. Remove the hoist from the unit. Tighten bolts (3).

9. Reinstall the mounting bolt that holds the cover to the front of the recoil spring assembly.

10. Using a pry bar, slide the front idler the remainder of the way into the undercarriage frame assembly.

End By:

a. connect track assemblies

Previous Screen

Product: EXCAVATOR

Model: 320B EXCAVATOR 8ES

Configuration: SUPPLEMENTARY SERVICE INFORMATION (DISASSEMBLY & ASSEMBLY) F 8ES00001-UP (MACHINE)

Disassembly and Assembly

320B, 320B L, 320B LN, 320B N, & 320B S EXCAVATORS MACHINE SY

Media Number -SEN9257-06

Publication Date -01/04/2004

Date Updated -18/01/2017

SEN92570020

Front Idlers

SMCS - 4159-017

Disassemble & Assemble Front Idlers

Tools Needed		A	B
1U-8842	Seal Installer	1	
8T-5096	Dial Indicator Group		1

Fluid Spillage Containment

Care must be taken to ensure that the fluids are contained during performance of the inspection, the maintenance, the testing, the adjusting and the repair of the machine. Be prepared to collect the fluid with suitable containers before opening any compartment or disassembling any component containing fluids. Refer to the "Tools And Shop Products Guide, NENG2500" the tools and the supplies suitable to collect and contain any of the fluids in Caterpillar machines. Dispose of the fluids according to local regulations and mandates.

Start By:

a. remove front idlers, recoil springs and hydraulic track adjusters

1. Thoroughly clean the outside of the front idler prior to disassembly.

2. Remove the fill/drain plug from the front idler. Drain the oil from the idler in a suitable container for disposal. The capacity of the idler is **180 ml (6.12 oz)**.

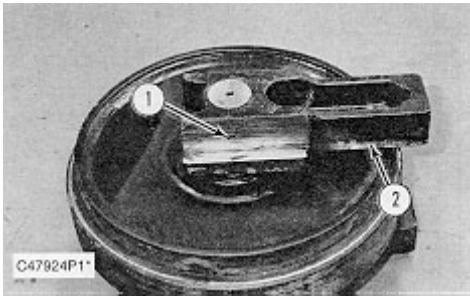

3. Put the front idler on its side, as shown. The weight of the front idler is **109 kg (240 lb)**.

4. Remove two spring pins (1) from bearings (2). Fasten a hoist to two bearings (2), and remove them from the shaft of the front idler. The weight of each bearing is **approximately 18 kg (40 lb)**.

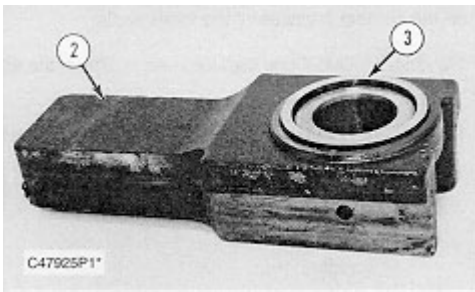

5. Remove Duo-Cone seals (3) from bearings (2).

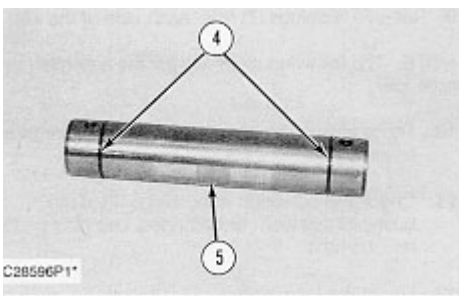
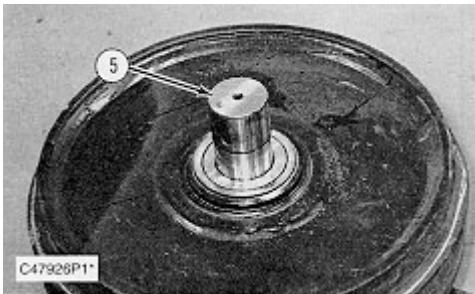

6. Remove shaft (5) from the front idler.

7. Remove two O-ring seals (4) from shaft (5).

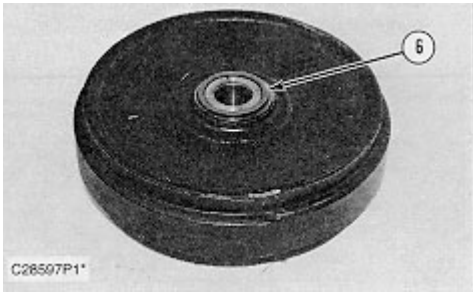

8. Remove Duo-Cone seal (6) from each side of the front idler.



9. Remove bushings (7) from each side of the idler.

NOTE: The following steps are for the assembly of the front idler.

10. Thoroughly clean all parts of the front idler prior to assembly.

11. Check the condition of bushings (7). If the bushings are worn or damaged, use new parts for replacement.

12. Lower the temperature of bushings (7), and install one in each side of the front idler with a press.

13. Temporarily install a bearing (2) on shaft (5). Install the shaft in the front idler. Install the other bearing (2) on the shaft. Use Tooling (B) to check the end play of the shaft. The shaft end play must be **0.25 to 1.15 mm (.010 to .045 in)**. Remove two bearings (2) and shaft (5) from the front idler.

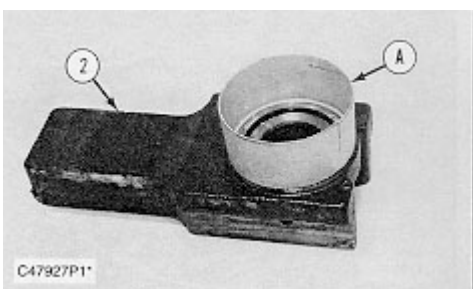
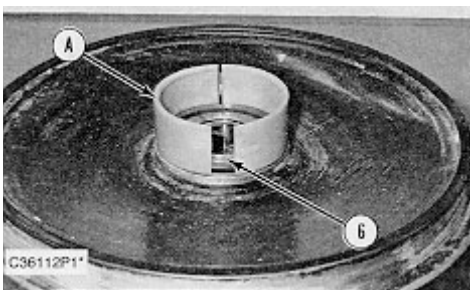

NOTICE

Refer to the topic "Assembly And Installation Of Conventional Duo-Cone Seals" in this module.

NOTE: The rubber seals and all of the surfaces that make contact with the seals must be clean and dry. After the installation of the seals, put clean SAE 30 oil on the contact surfaces of the metal seals.

14. Install a Duo-Cone seal (6) in each side of the idler with Tool (A).

15. Install a Duo-Cone seal (3) in each bearing (2) with Tool (A).

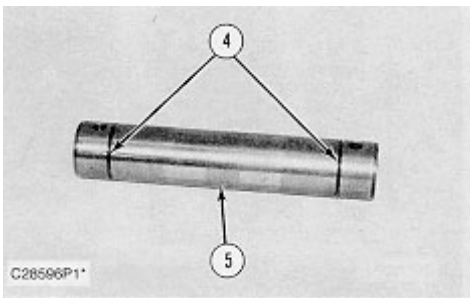

16. Check the condition of O-ring seals (4) used on shaft (5). If the O-ring seals are worn or damaged, use new parts for replacement.

17. Install two O-ring seals (4) on shaft (5). Put clean **SAE 30** oil on the O-ring seals.

18. Check the condition of spring pins (1) used to hold bearings (2) to shaft (5). If the spring pins are worn or damaged, use new parts for replacement.

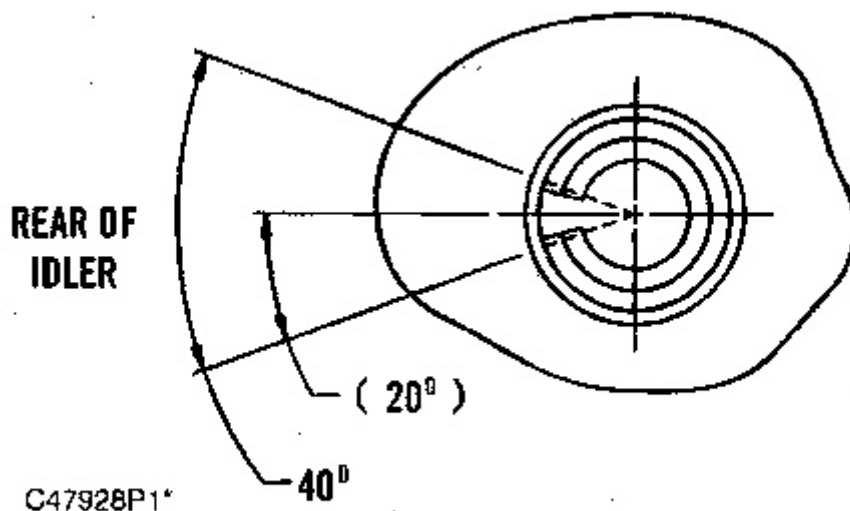

- 19.** Install shaft (5) in either bearing (2). Be sure the spring pin hole in the shaft is in alignment with the spring pin hole in the bearing. Also be sure the marking "R" and the milled surface if the shaft is facing toward the rear of the bearing as positioned in the machine.
- 20.** Install a new spring pin (1) to hold the unit together. Position the slit in the spring pin as shown in Illustration C47928P1.
- 21.** Install the shaft and bearing in the front idler.
- 22.** Install the other bearing (2) on the shaft (5) as in Step 19. Be sure the spring pin hole in the shaft is in alignment with the spring pin hole in the bearing.
- 23.** Install a new spring pin (1) to hold the bearing to the shaft as in Step 20.
- 24.** Check the front idler for air leaks. Apply **245 to 265 kPa (35.5 to 38.5 psi)** of air to the idler for a minimum of **30 seconds**. If the pressure gauge reading does not change in a **30 second time period**, it can be assumed there are no leaks in the front idler.
- 25.** Put the front idler in a vertical position. Fill the front idler with **180 ml (12.9 ± 6.12 oz)** of clean **SAE 30 oil**.
- 26.** Put a thin coat of **9S-3263 Thread Lock** on the threads of the fill/drain plug, and reinstall it.

End By:

- a.** install front idlers, recoil springs and hydraulic track adjusters

Previous Screen

Product: EXCAVATOR

Model: 320B EXCAVATOR 8ES

Configuration: SUPPLEMENTARY SERVICE INFORMATION (DISASSEMBLY & ASSEMBLY) F 8ES00001-UP (MACHINE)

Disassembly and Assembly

320B, 320B L, 320B LN, 320B N, & 320B S EXCAVATORS MACHINE SY

Media Number -SEN9257-06

Publication Date -01/04/2004

Date Updated -18/01/2017

SEN92570021

Recoil Springs

SMCS - 4158-017

Disassemble & Assemble Recoil Springs

Tools Needed		A	B	C	D	E	F
4C-9540	Recoil Spring Bench Group	1					
8S-7172	Hydraulic Cylinder Group		1				
3S-6224	Electric Hydraulic Pump			1			
8S-9971	Ram Adapter				1		
132-8743	Socket (65 mm)					1	
1P-0520	Driver Group						1

Start By:

- a. remove front idlers, recoil springs and hydraulic track adjusters



The recoil spring assembly is assembled with a force of several tons. Do Not put the spring under compression or release the tension with nut (8) that holds the unit together. Damaged threads on recoil spring retaining rod or in nut (8) that holds the unit together, can cause the assembly to come apart with force, resulting in personal injury or death.

NOTE: Do Not remove the hydraulic track adjuster from the recoil spring assembly.

1. Prior to disassembling and assembling the recoil spring assembly, make sure Tooling (A) is on a level surface.
2. Thoroughly clean the outside surface of the recoil spring assembly and the hydraulic track adjuster.

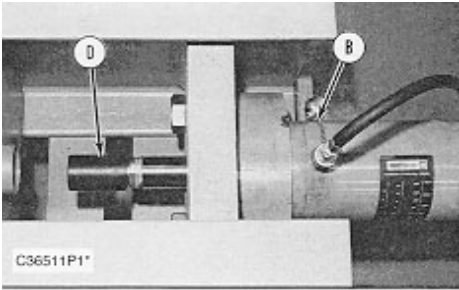

3. Install Tool (D) on Tooling (B) as shown.

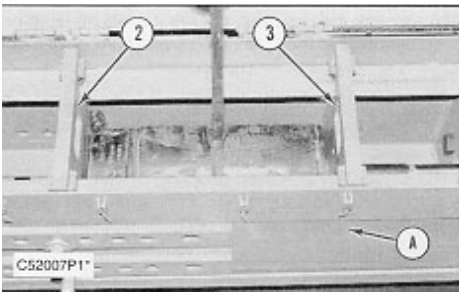
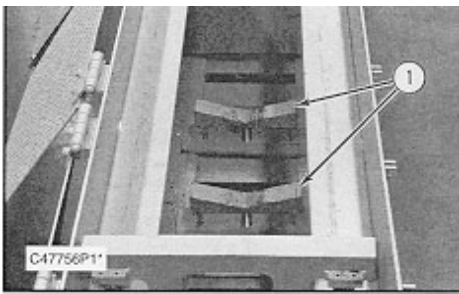

NOTE: Two adjustable supports (1), reaction plate (2) and movable plate (3) are part of Tooling (A).

4. Adjust the spacing between reaction plate (2) and movable plate (3) so it is approximately the same length of the recoil spring assembly. Also, make sure two adjustable supports (1) are positioned between the reaction plate and the movable plate as shown. Level the two supports.

NOTICE

Do Not remove the hoist from the recoil spring assembly until the unit is leveled, centered and locked in Tooling (A).

NOTE: The recoil spring assembly may have to be installed in Tooling (A) from the end. In this case, reaction plate (2) must be removed; then reinstalled after the recoil spring assembly is in place on two adjustable supports (1).

5. The combined weight of the recoil spring assembly and the hydraulic track adjuster is **95 kg (210 lb)**. Fasten a hoist to the recoil spring assembly. Put the recoil spring assembly in position on two adjustable supports (1) in Tooling (A). Adjust the two adjustable supports to align the centerline of the recoil spring assembly with the centerline of Tooling (A).

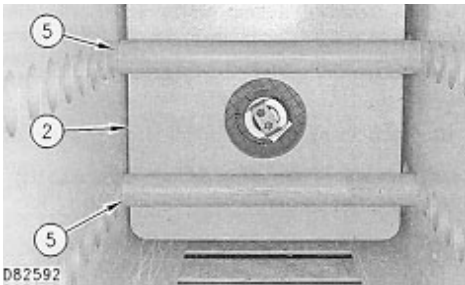
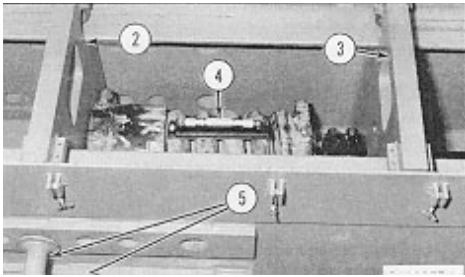

NOTE: The hoist has been removed from the recoil spring assembly only for better photo illustration of level (4).

6. Put a level (4) on the recoil spring assembly. Reposition the recoil spring assembly until it is level, and the recoil spring retaining rod and the nut are centered in the hole in reaction plate (2) as shown in Photo D82592. The recoil spring assembly is leveled by moving adjustable supports (1) up or down. After the recoil spring assembly is leveled and centered, install two pins (5) on the back side of reaction plate (2) as shown. Operate Tooling (B) a small amount to hold the recoil spring assembly in position between reaction plate (2) and movable plate (3). Again, check to make sure the recoil spring assembly is level and centered.

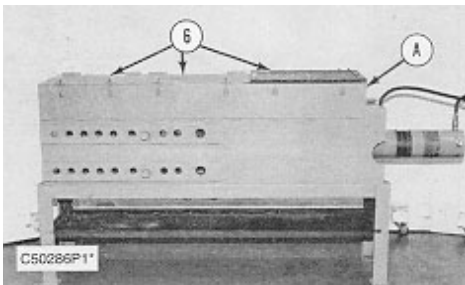

WARNING

The recoil spring assembly is assembled under a force of several tons. Do Not put the recoil spring assembly under compression until covers (6) on Tooling (A) have been closed. It is possible for the recoil spring assembly to twist and come out of Tooling (A) resulting in personal injury or death.



Suggest:

If the above button click is invalid.

Please download this document

first, and then click the above link

to download the complete manual.

Thank you so much for reading

7. Close covers (6) on Tooling (A). Use Tooling (B), compress the recoil spring assembly a small amount.

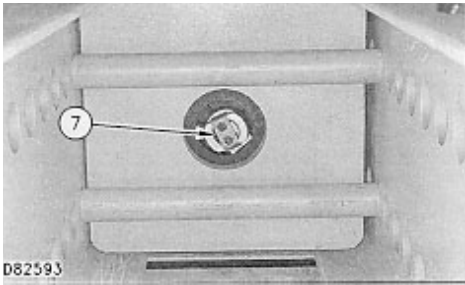

8. Through the opening in the end of Tooling (A), remove the two socket head bolts and lock strip (7) from the end of the recoil spring retaining rod.

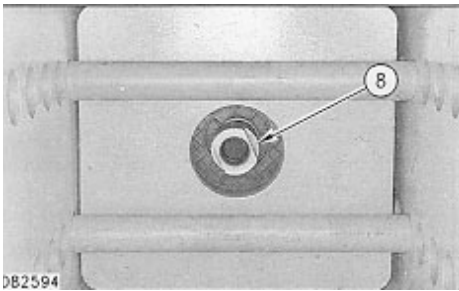

9. Remove nut (8) with Tool (E). Remove the washer from behind nut (8). Release the force on the recoil spring assembly.

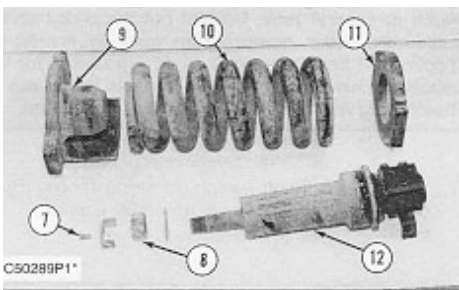

10. Open the covers on Tooling (A). Fasten a hoist to the recoil spring assembly, and remove it from Tooling (A).

11. Separate the components of the recoil spring assembly. Remove the recoil spring retaining rod and cylinder (12), plate (11), spring (10) and support (9).

12. Remove the hydraulic track adjuster from cylinder (12). Refer to the topic "Disassemble & Assemble, Hydraulic Track Adjuster" in this module.

13. Remove the recoil spring retaining rod from cylinder (12).

14. Remove the lip seal and the up ring and the seal from cylinder (12).

NOTE: The following steps are for the assembly of the recoil spring assembly.

15. Install the up ring and the seal in cylinder (12).

<https://www.ebooklibonline.com>

Hello dear friend!

Thank you very much for reading.

Enter the link into your browser.

The full manual is available for immediate download.

<https://www.ebooklibonline.com>