



Service Repair Manual

Model

245B SERIES II EXCAVATOR

Previous Screen

Product: EXCAVATOR

Model: 245B EXCAVATOR 6MF

Configuration: 245B SERIES II EXCAVATOR 6MF00513-UP (MACHINE) POWERED BY 3406 ENGINE

Disassembly and Assembly
37-MT, 41-MT, and 42-MT Series Starting Motors

Media Number -SEN3581-04

Publication Date -01/10/2008

Date Updated -24/10/2008

i01557321

General Information

SMCS - 1453

37-MT and 41-MT Starting Motors

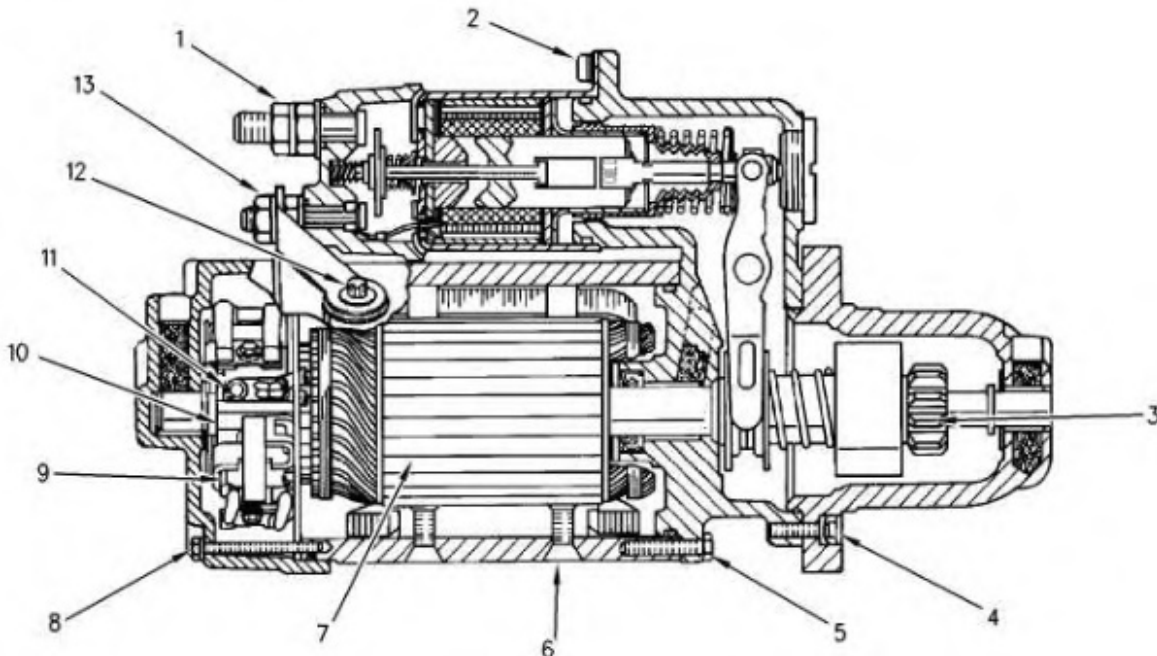

Illustration 1

g00782868

37-MT and 41-MT Cross section view

- (1) Nut (Battery)
- (2) Solenoid Mounting Screws
- (3) Pinion

- (4) Pinion Drive Housing Bolts
- (5) Shift Lever Housing Bolts
- (6) Field Winding Screws
- (7) Laminated Core
- (8) Rear Housing Bolts
- (9) Brush
- (10) Commutator
- (11) Brush Lead Screws
- (12) Motor Terminal Bolt
- (13) Motor Terminal Nut

42-MT Starting Motors

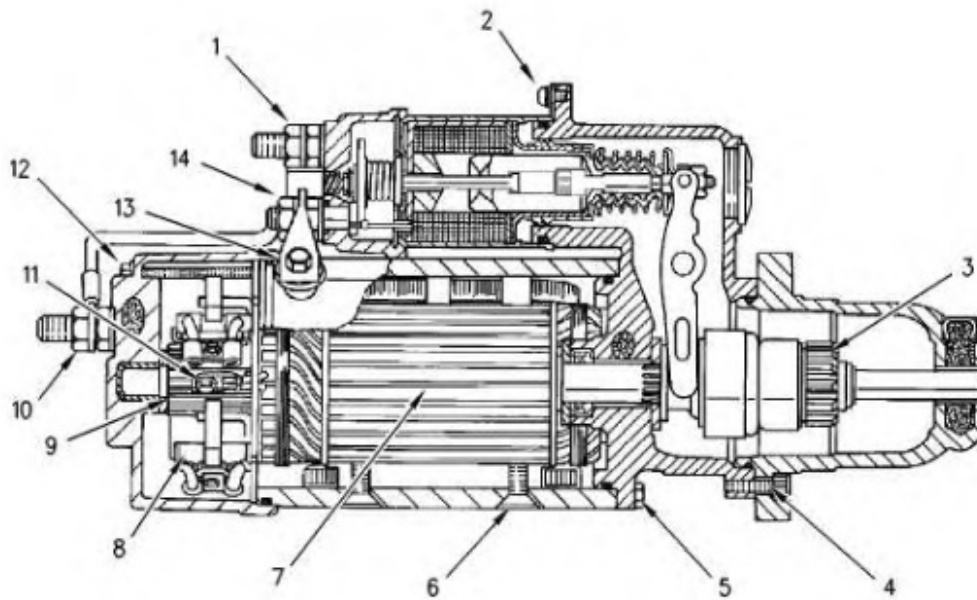

Illustration 2

g00801373

42-MT Cross section view

- (1) Nut (Battery)
- (2) Solenoid Mounting Screws
- (3) Pinion
- (4) Pinion Drive Housing Bolts
- (5) Shift Lever Housing Bolts

<https://www.ebooklibonline.com>

Hello dear friend!

Thank you very much for reading.

Enter the link into your browser.

The full manual is available for immediate download.

<https://www.ebooklibonline.com>

- (6) Field Winding Screws
- (7) Laminated Core
- (8) Brush
- (9) Commutator
- (10) Ground Terminal Nut
- (11) Brush Lead Screws
- (12) Rear Housing Bolt
- (13) Motor Terminal Bolt
- (14) Motor Terminal Nut

Previous Screen

Product: EXCAVATOR

Model: 245B EXCAVATOR 6MF

Configuration: 245B SERIES II EXCAVATOR 6MF00513-UP (MACHINE) POWERED BY 3406 ENGINE

**Disassembly and Assembly
37-MT, 41-MT, and 42-MT Series Starting Motors**

Media Number -SEN3581-04

Publication Date -01/10/2008

Date Updated -24/10/2008

i01559954

Starting Motor - Disassemble - 42-MT

SMCS - 1453-015

Disassemble the Starting Motor

Note: The disassembly and assembly that follows is of the 24 volt starting motor. The 12 volt is similar.

Table 1

Required Tools			
Tool	Part Number	Part Description	Quantity
A	1P-1855	Retaining Ring Pliers	1
B	1P-0510	Driver Gp	1

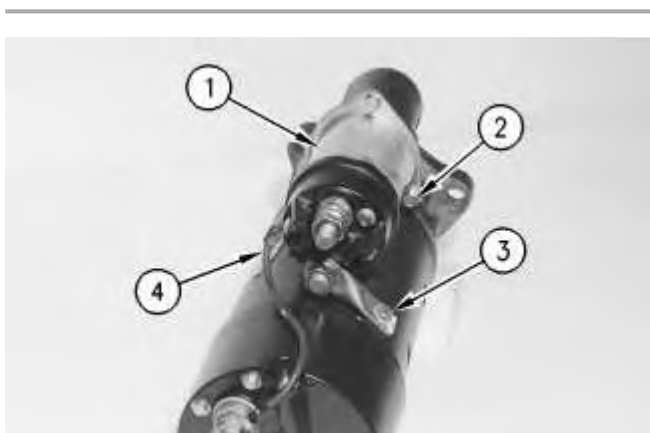

Illustration 1

g00810559

1. Disconnect wire assembly (4) from solenoid (1). Disconnect motor terminal connector (3) from the starting motor housing.
2. Remove three bolts (2) from the shift lever housing. Do not disassemble the solenoid. The parts inside the solenoid are not serviceable.



Illustration 2

g00818016

3. Remove the O-ring seal and bushing (5) .

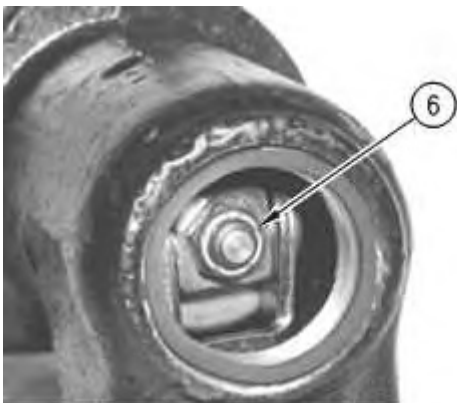

Illustration 3

g00810580

4. Remove the nut (6). Remove the solenoid from the shift lever housing.
-

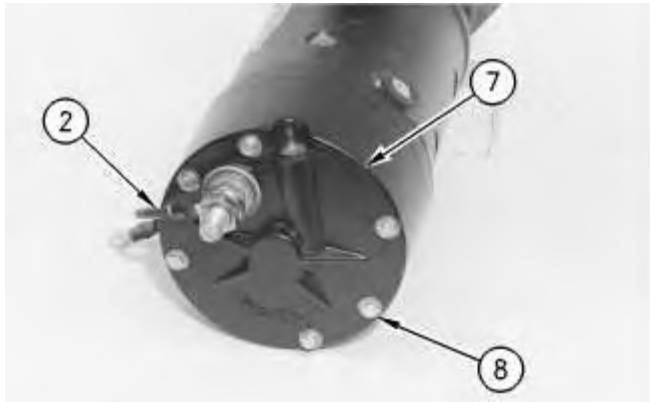

Illustration 4

g00810574

5. Remove the negative terminal nuts "-", wire assembly (2), and washers. Remove six bolts (8) and rear housing (7) .



Illustration 5

g00818558

6. If necessary, remove bushing (9) from the rear housing.

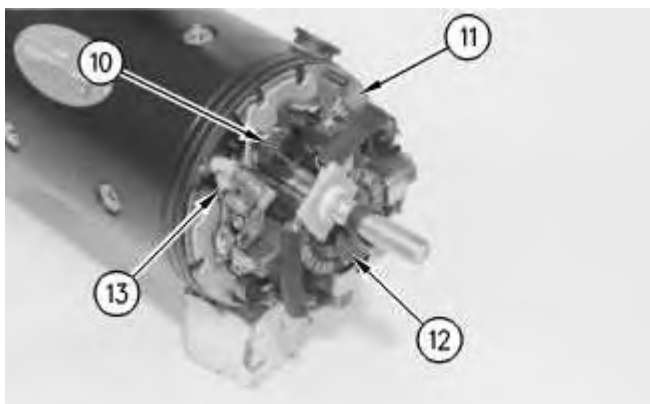

Illustration 6

g00810576

7. Remove washer (12) from the armature shaft. Lift brush springs (10) and pull the brushes away from the commutator. Position the brush springs (10) on the side of the brushes in order to hold the brushes in the holders.
8. Disconnect field winding leads (13) from brush holder (11). Remove the brush holder.

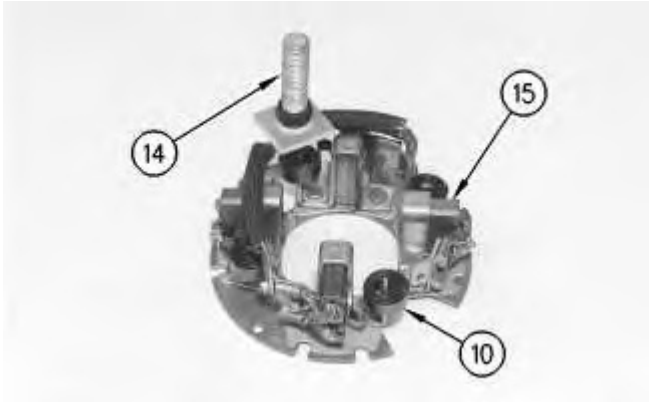

Illustration 7

g00818538

9. Remove brushes (15) and negative "-" terminal (14) from the brush holders.

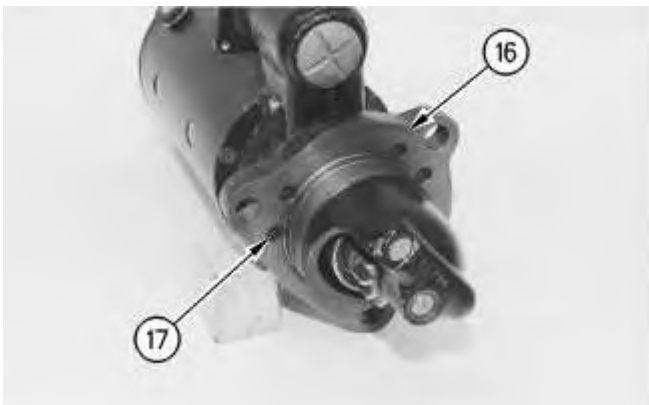

Illustration 8

g00810579

10. Scribe a line on the pinion drive, the shift lever and the starting motor housings for the correct alignment at assembly.
 11. Remove six bolts (17) and pinion drive housing (16) .
-

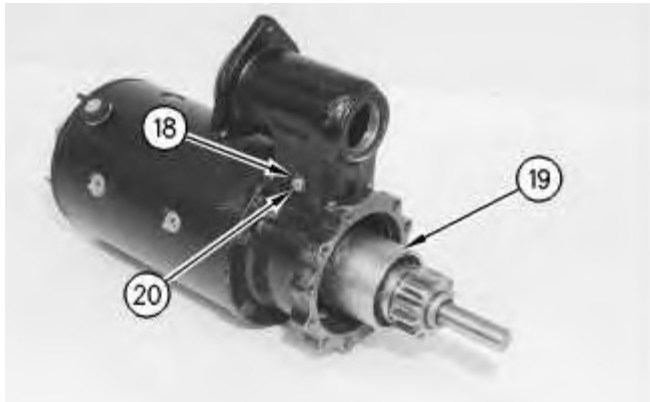

Illustration 9

g00810582

12. Remove retainer (18) with tool (A). Remove shift lever pin (20). If necessary, remove the O-ring seals from the shift lever pin.
13. Remove pinion drive (19) and the shift lever.

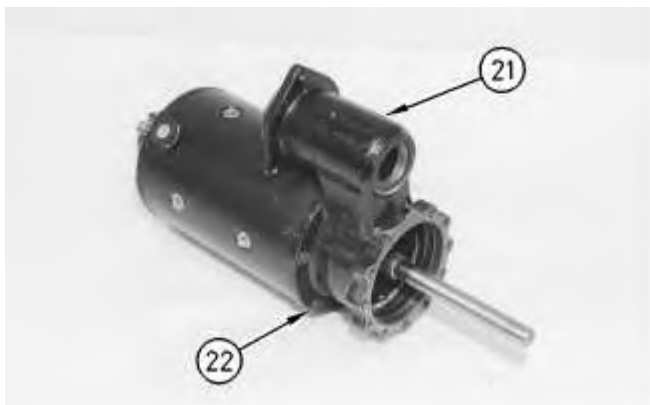

Illustration 10

g00810585

14. Remove the brake disc from the armature shaft. Remove five bolts (22), shift lever housing (21) and the washer. If necessary, remove the outside O-ring seals.
 15. If necessary, remove the seal and the bushing from the shift lever housing.
-



Illustration 11

g00810588

16. Remove armature (22) from the starting motor housing.

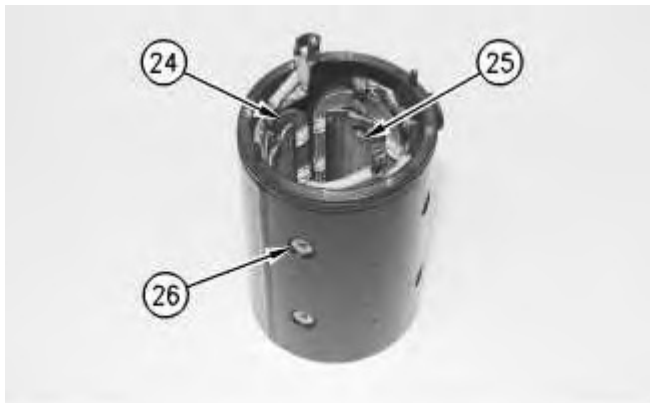

Illustration 12

g00810589

17. Remove the following components from the starting motor housing: eight screws (26), pole shoes (25) and field winding coil (24). It may be necessary to use an impact driver to remove screws (26) .
18. Clean the armature, field winding coil and pinion drive with mineral spirits and a brush.
Note: If the commutator is dirty, the commutator may be cleaned with Number 00 sandpaper. Do not use emery cloth.
19. Inspect all parts for wear and damage.

Previous Screen

Product: EXCAVATOR

Model: 245B EXCAVATOR 6MF

Configuration: 245B SERIES II EXCAVATOR 6MF00513-UP (MACHINE) POWERED BY 3406 ENGINE

Disassembly and Assembly
37-MT, 41-MT, and 42-MT Series Starting Motors

Media Number -SEN3581-04

Publication Date -01/10/2008

Date Updated -24/10/2008

i01365545

Starting Motor - Disassemble - 37-MT and 41-MT

SMCS - 1453-015

Disassemble the Starting Motor

Start By:

- A. Remove the starting motor from the machine.

Note: The disassembly of the 12 volt starting motor is similar to the disassembly of the 24 volt starting motor.

Table 1

Required Tools			
Tool	Part Number	Description	Quantity
A	1P-1855	Retaining Ring Pliers	1

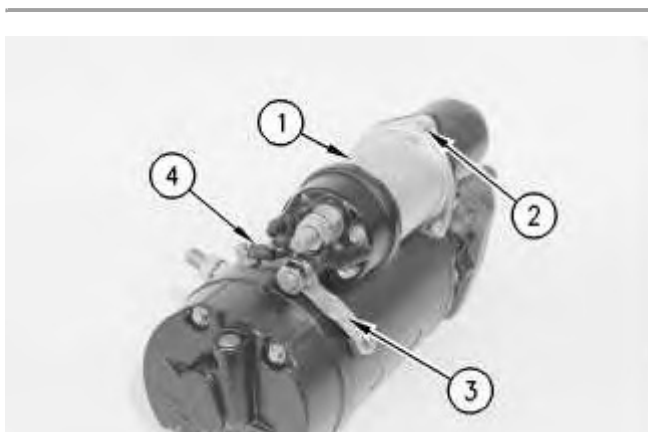

1. Disconnect and remove shunt wire assembly (4) and motor terminal connector "MTR" (3) from the solenoid (1) and starting motor.



Illustration 2

g00820183

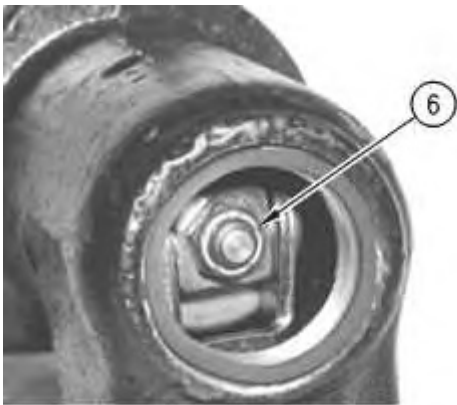

Illustration 3

g00810580

2. Remove the plug (5) and seal from the shift lever housing. Remove the nut (6) that is inside the shift lever housing. The nut holds the plunger to the shift lever.
 3. Remove bolts (2) and solenoid (1) from the shift lever housing. Do not disassemble the solenoid. The parts inside the solenoid are not serviceable.
-

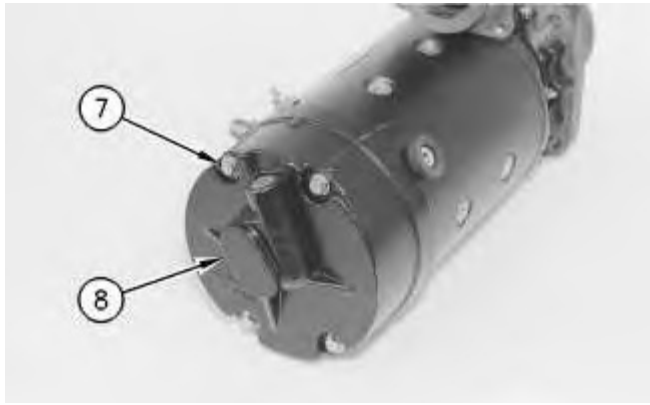

Illustration 4

g00810222



Illustration 5

g00810478

4. Mark the following components for correct assembly: rear housing (8), pinion drive, shift lever housing and starting motor housing. Remove four bolts (7) and rear housing (8). Remove washer (9) from the armature. Remove the O-ring seal from the starting motor housing, if necessary.



Illustration 6

g00810242

5. Remove bushing (10) from the rear housing, if necessary.

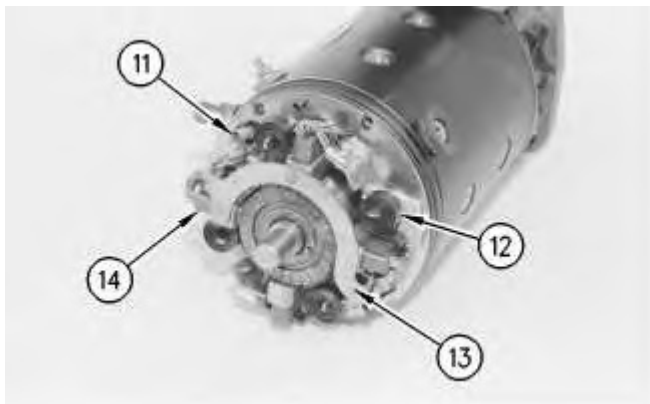

Illustration 7

g00810245

6. Lift each brush spring (12) and put the spring on the left side of the brush (14). Disconnect three leads (11) and remove brush holder (13) .
7. Remove brushes (14) from the brush holder.

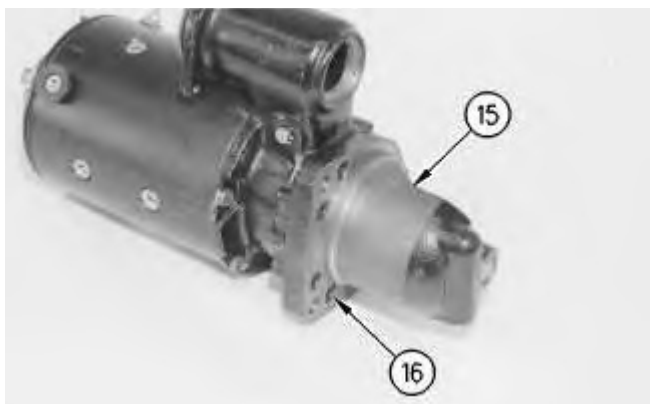

Illustration 8

g00810249

8. Remove six bolts (16) and pinion drive housing (15) .
-



Illustration 9

g00810257

9. Remove bushing (17) from the pinion drive housing, if necessary.

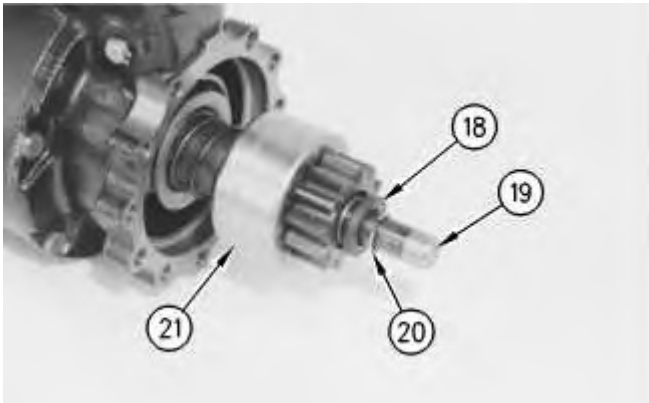

Illustration 10

g00810266

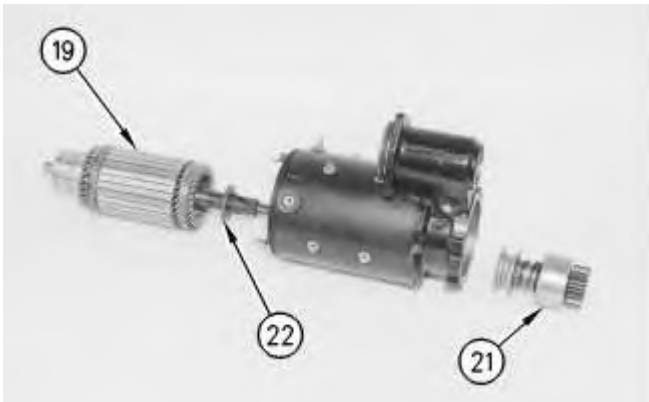

Illustration 11

g00810429

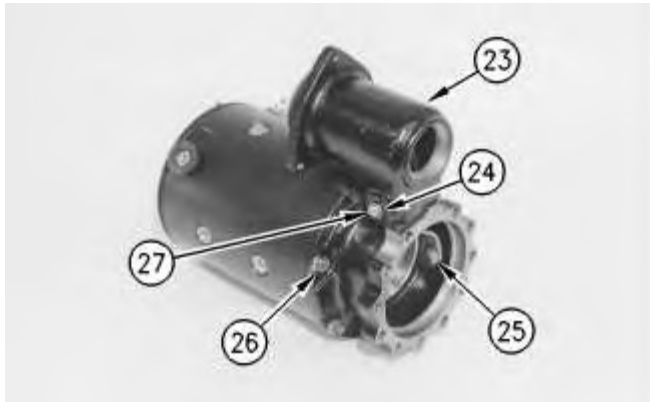

Illustration 12

g00810272

10. Drive retainer (18) backward away from ring (20) that is below the retainer. Remove the ring and the retainer. Remove armature (19) from pinion drive (21) and the starting motor and the shift lever housing (23). Remove the washer (22) from the armature (19) .

Note: The pinion drive that is on the 41-MT starting motor is not the same pinion drive that is shown. The pinion drive is similar to a 42-MT starting motor. Refer to Disassembly and Assembly, "Starting Motor - Disassemble".

11. Remove pinion drive (21) from the shift lever forks (25) .
12. Remove five bolts (26) and shift lever housing (23). Remove ring (24) with tool (A), pin (27) and shift lever (25). Remove the seals from the pin, if necessary.
13. Remove the O-ring seal from the shift lever housing, if necessary.



Illustration 13

g00810276

14. Remove seal (28) and bushing (29) from the shift lever housing, if necessary.



Illustration 14

g00810281

15. Remove eight screws (32), field winding coil (30), and pole shoes (31) from the starting motor housing. It may be necessary to use an impact driver to remove screws (32). One of the screws is the negative terminal.
16. Clean the armature, field winding coil, and pinion drive with mineral spirits and a brush.
Note: If the commutator is dirty, the commutator may be cleaned with Number 00 sandpaper. Do not use emery cloth.
17. Inspect all parts for wear and damage.

[Previous Screen](#)

Product: EXCAVATOR

Model: 245B EXCAVATOR 6MF

Configuration: 245B SERIES II EXCAVATOR 6MF00513-UP (MACHINE) POWERED BY 3406 ENGINE

Disassembly and Assembly 37-MT, 41-MT, and 42-MT Series Starting Motors

Media Number -SEN3581-04

Publication Date -01/10/2008

Date Updated -24/10/2008

i01560148

Starting Motor - Assemble - 42-MT

SMCS - 1453-016

Assemble the Starting Motor

Table 1

Required Tools			
Tool	Part Number	Part Description	Quantity
A	1P-1855	Retaining Ring Pliers	1
B	1P-0510	Driver Gp	1

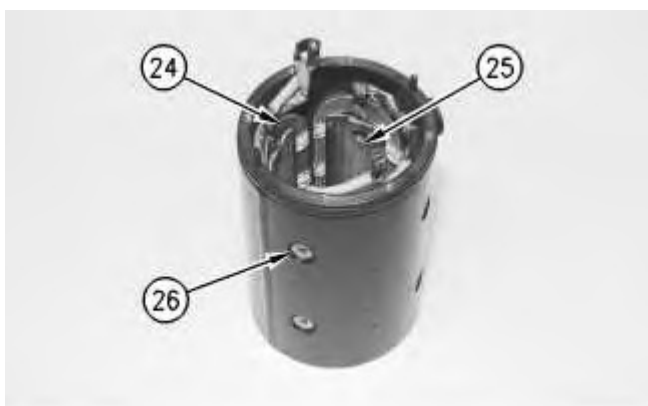

Illustration 1

g00810589

1. Put SAE 20W oil on all bushings, seals and oil wicks.

- Put field winding coil (24) and pole shoes (25) in position in the starting motor housing. Put **9s-3263** Thread Lock Compound on the threads of screws (26). Tighten screws (26) to a torque of 20.3 ± 2.3 N·m (179.7 ± 20.4 lb in).



Illustration 2

g00810588

- Put **5P-0960** Molybdenum Grease on the armature bushing areas. Do not put grease on the armature core or the commutator. Put armature (23) into the starting motor housing.

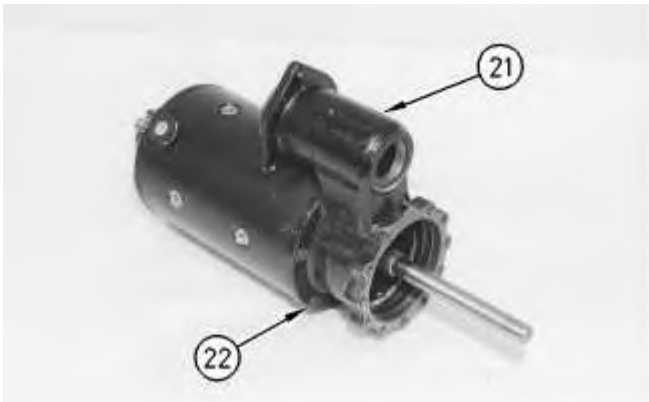

Illustration 3

g00810585

- Install the outside O-ring seals if it is necessary. Install the shift lever housing (21). Install five bolts (22). Install the brake disc on the armature shaft.
-

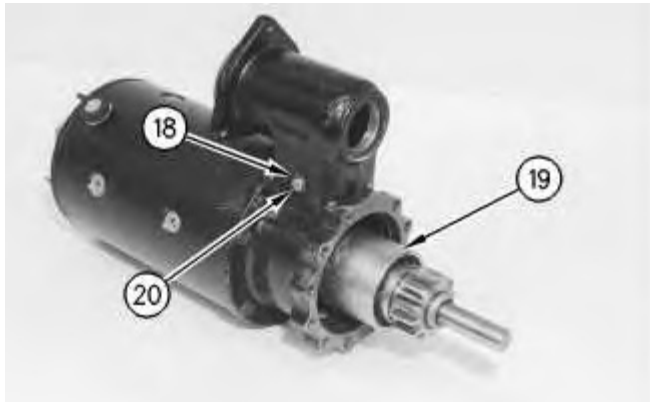

Illustration 4

g00810582

5. Install the pinion drive (19) and the shift lever. Install the O-ring seal if it is necessary. Install the shift lever pin (20). Install the retainer (18) with tool (A) .

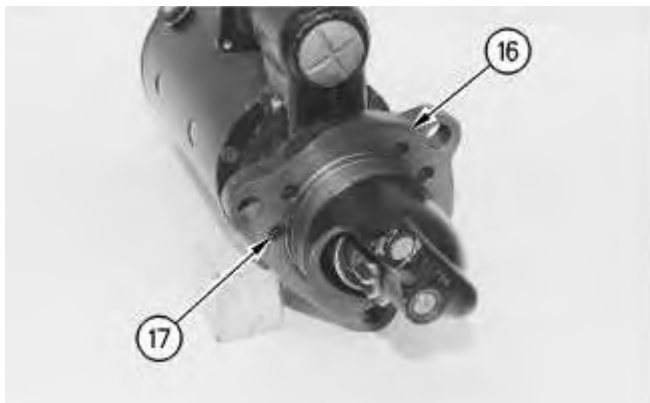

Illustration 5

g00810579

6. Align the pinion drive housing (16). Install six bolts (17) .

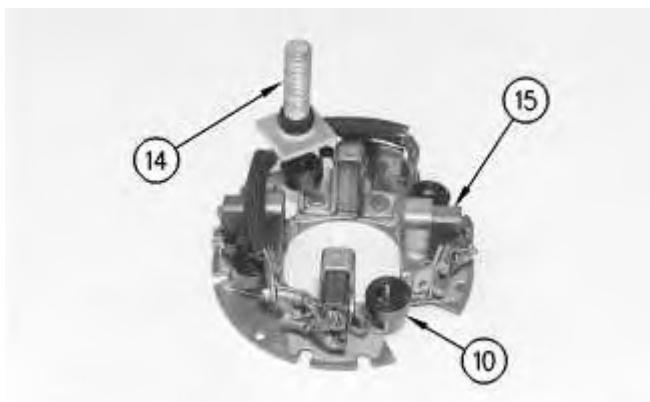

Illustration 6

g00818538

7. Install brushes (15) and negative "-"terminal (14) in the brush holders. Install brush spring (10) against the side of each brush.

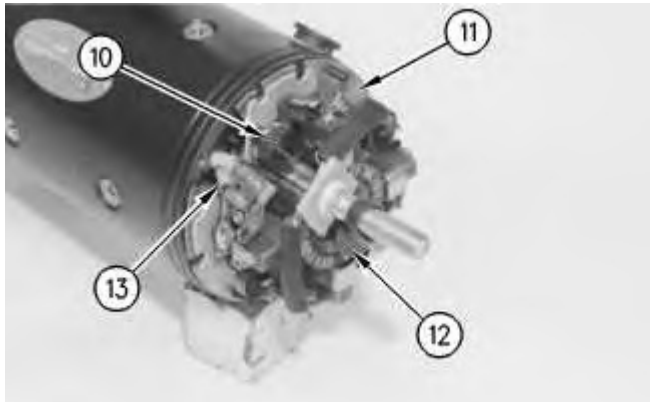

Illustration 7

g00810576

8. Install the brush holder. Connect the field winding leads (13) to the brush holder (11) .
9. Put the washer (12) onto the armature assembly. Push the brushes (10) into the holders so that the springs are on top of the brushes.



Illustration 8

g00818558

10. Install the bushing (9) into the rear housing if it is necessary.
-

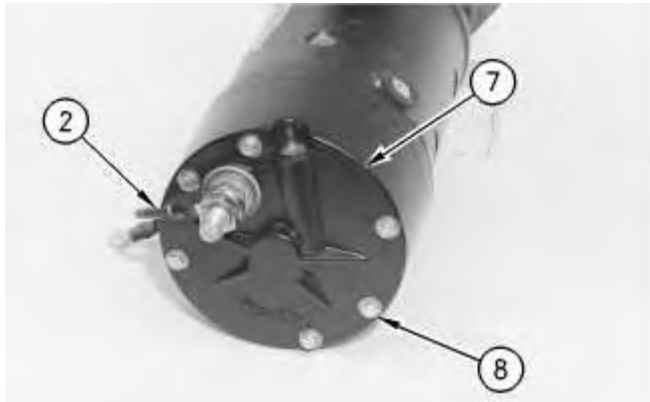

Illustration 9

g00810574

11. Install six bolts (8) and rear housing (7). Torque bolts (8) to $5.7 \pm 1.1 \text{ N}\cdot\text{m}$ ($50.4 \pm 9.7 \text{ lb in}$). Install wire assembly (2), washers, and negative terminal nuts "-".

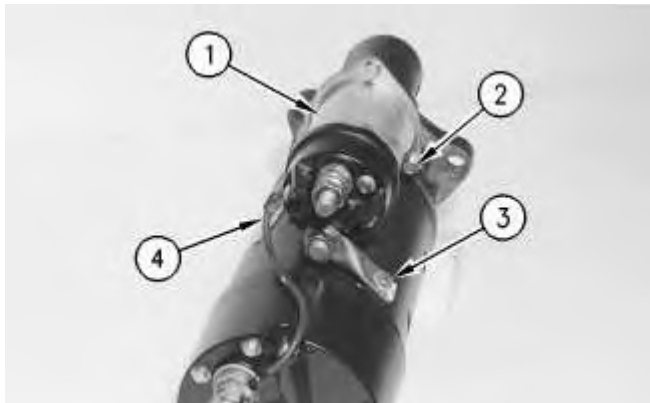
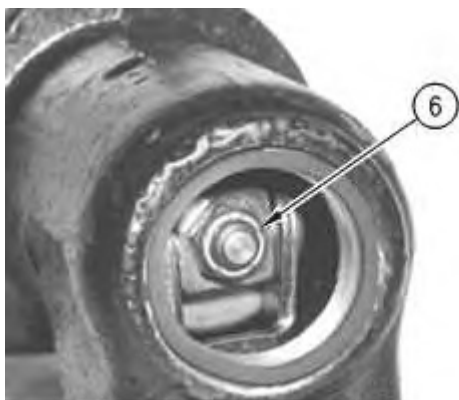

Illustration 10

g00810559

12. Install solenoid (1). Align the solenoid link with the hole in the shift lever. Install three bolts (2) in the shift lever housing. Torque bolts (2) to $17.8 \pm 3.7 \text{ N}\cdot\text{m}$ ($157.5 \pm 32.7 \text{ lb in}$).
13. Install wire assembly (4). Connect motor terminal "MTR" (3) to the starter motor housing.



14. Install pinion clearance adjustment nut (6) .
15. Adjust pinion clearance. Refer to Testing and Adjusting, "Pinion Clearance - Adjust" for pinion clearance adjustments.



Illustration 12

16. Install the O-ring seal and bushing (5) .

[Previous Screen](#)

Product: EXCAVATOR

Model: 245B EXCAVATOR 6MF

Configuration: 245B SERIES II EXCAVATOR 6MF00513-UP (MACHINE) POWERED BY 3406 ENGINE

Disassembly and Assembly 37-MT, 41-MT, and 42-MT Series Starting Motors

Media Number -SEN3581-04

Publication Date -01/10/2008

Date Updated -24/10/2008

i01559761

Starting Motor - Assemble - 37-MT and 41-MT

SMCS - 1453-016

Assemble the Starting Motor

Table 1

Required Tools			
Tool	Part Number	Description	Quantity
A	1P-1855	Retaining Ring Pliers	1
B	1P-0510	Driver Gp	1

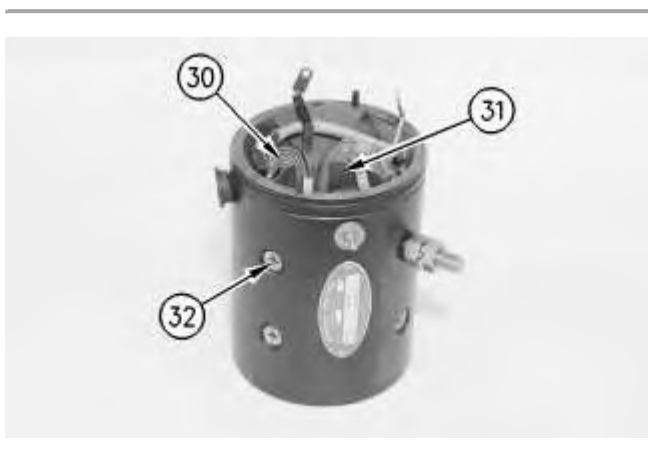

Illustration 1

g00810281

1. Put SAE 20W oil on all bushings, seals and oil wicks.

- Put field winding coil (29) and pole shoes (30) in position in the starting motor housing. Put **9s-3263** Thread Lock Compound on the threads of screws (31). Tighten to a torque of $20.3 \pm 2.3 \text{ N}\cdot\text{m}$ ($179.7 \pm 20.4 \text{ lb in}$).



Illustration 2

g00810276

- Install bushing (27) and seal (28) into the shift lever housing. Use tool group (B) .

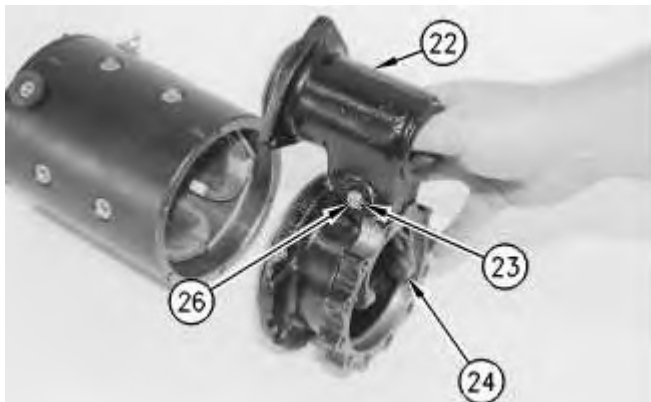

Illustration 3

g00810419

- Put the O-ring on the shift lever housing (22) .
 - Install the seals on pin (26). Hold shift lever (24) in shift lever housing (22) and install pin (19) through the housing and lever (24). Install ring (23) with tool (A) .
-



Suggest:

If the above button click is invalid.

Please download this document

first, and then click the above link

to download the complete manual.

Thank you so much for reading

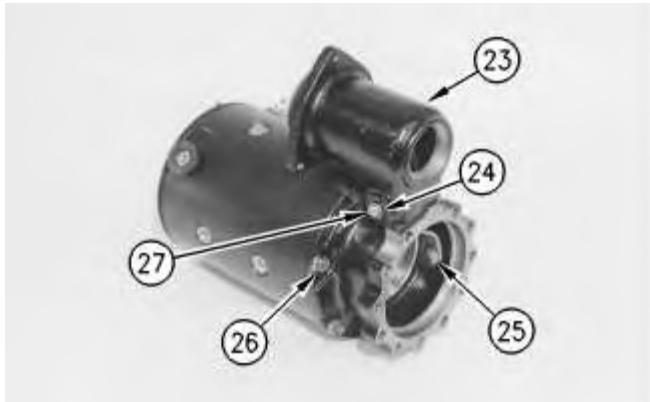

Illustration 4

g00810272

- Put shift lever housing (22) in position on the starting motor housing. Install bolts (25) and tighten bolts (25) to a torque of $18.9 \pm 2.6 \text{ N}\cdot\text{m}$ ($167.3 \pm 23.0 \text{ lb in}$).

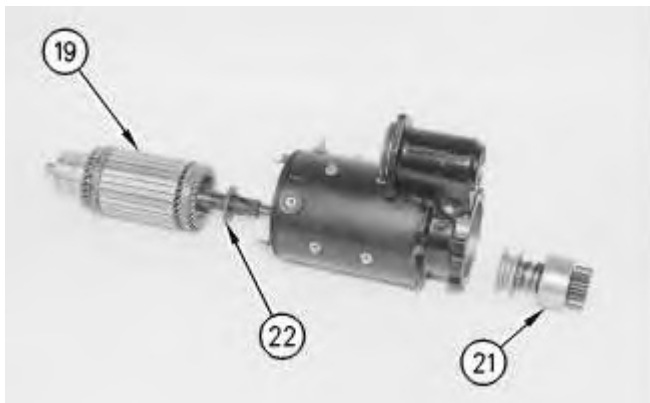

Illustration 5

g00810429

- Put **5P-0960** Molybdenum Grease on the armature bushing areas. Do not put grease on the armature core or the commutator. Install washer (21) on armature (18). Put armature (18) into the starting motor housing. Hold pinion drive (20) in the shift lever fork and insert armature (18) through the shift housing and pinion drive.

Note: The pinion drive that is on the 41-MT starting motor is not same pinion drive that is shown. The pinion drive is similar to a 42-MT starting motor. Refer to Disassembly and Assembly, "Starting Motor - Assemble".

<https://www.ebooklibonline.com>

Hello dear friend!

Thank you very much for reading.

Enter the link into your browser.

The full manual is available for immediate download.

<https://www.ebooklibonline.com>