



# Service Repair Manual

## **Model**

**235D EXCAVATOR**

---

[Previous Screen](#)

Product: EXCAVATOR

Model: 235D EXCAVATOR 8KJ

Configuration: 235D EXCAVATOR 8KJ00001-UP (MACHINE) POWERED BY 3306 ENGINE

## Disassembly and Assembly 3304B and 3306B Engines for Caterpillar Built Machines

Media Number -SEN5598-09

Publication Date -01/01/2013

Date Updated -25/01/2013

i00984196

# Fuel Priming Pump - Remove and Install

SMCS - 1258-010

## Removal Procedure

---

### NOTICE

**Keep all parts clean from contaminants.**

**Contaminants may cause rapid wear and shortened component life.**

---

---

### NOTICE

**Care must be taken to ensure that fluids are contained during performance of inspection, maintenance, testing, adjusting and repair of the machine. Be prepared to collect the fluid with suitable containers before opening any compartment or disassembling any component containing fluids.**

**Refer to Special Publication, NENG2500, "Caterpillar Tools and Shop Products Guide", for tools and supplies suitable to collect and contain fluids in Caterpillar machines.**

**Dispose of all fluids according to local regulations and mandates.**

---

---

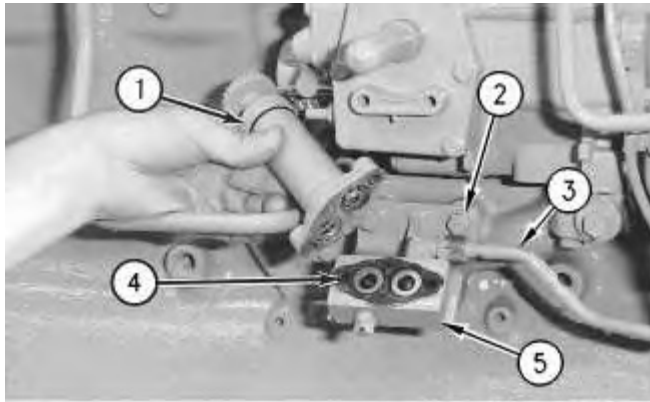

Illustration 1

g00500957

1. Turn the fuel supply line valve to the OFF position.
2. Remove the bolts and the washers that secure fuel priming pump (1) to base (5). Remove gasket (4) .
3. Disconnect tube assembly (3) .
4. Remove two bolts (2), the washers and base (5) from the cylinder block.

## Installation Procedure

---

### NOTICE

**Keep all parts clean from contaminants.**

**Contaminants may cause rapid wear and shortened component life.**

---

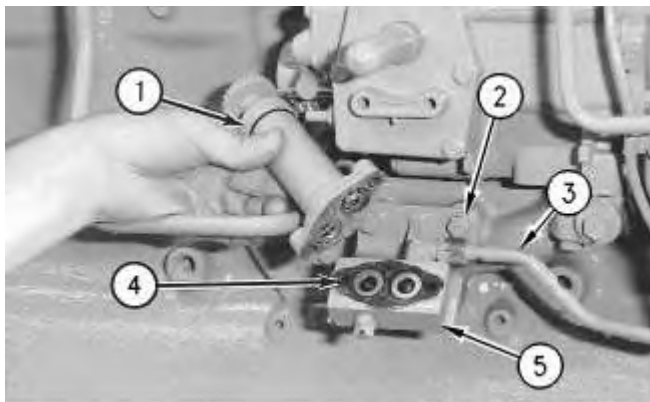

Illustration 2

g00500957

**<https://www.ebooklibonline.com>**

Hello dear friend!

Thank you very much for reading.

Enter the link into your browser.

The full manual is available for immediate download.

**<https://www.ebooklibonline.com>**

1. Install base (5), the washers and two bolts (2) .

2. Connect tube assembly (3) to base (5) .

**Note:** Check the condition of the gaskets. If the gaskets are worn or damaged, use new parts for replacement.

3. Install gasket (4). Install fuel priming pump (1) and the bolts that secure the fuel priming pump to base (5) .

4. Turn the fuel supply line valve to the ON position.

Previous Screen

Product: EXCAVATOR

Model: 235D EXCAVATOR 8KJ

Configuration: 235D EXCAVATOR 8KJ00001-UP (MACHINE) POWERED BY 3306 ENGINE

**Disassembly and Assembly  
3304B and 3306B Engines for Caterpillar Built Machines**

Media Number -SEN5598-09

Publication Date -01/01/2013

Date Updated -25/01/2013

i00917143

## Fuel Filter Base - Remove and Install

SMCS - 1262-010

### Removal Procedure

Table 1

Required Tools			
Tool	Part Number	Part Description	Qty
A	2P-8250	Strap Wrench Assembly	1

---

**NOTICE**

**Keep all parts clean from contaminants.**

**Contaminants may cause rapid wear and shortened component life.**

---

**NOTICE**

**Care must be taken to ensure that fluids are contained during performance of inspection, maintenance, testing, adjusting and repair of the machine. Be prepared to collect the fluid with suitable containers before opening any compartment or disassembling any component containing fluids.**

**Refer to Special Publication, NENG2500, "Caterpillar Tools and Shop Products Guide", for tools and supplies suitable to collect and contain fluids in Caterpillar machines.**

**Dispose of all fluids according to local regulations and mandates.**

---

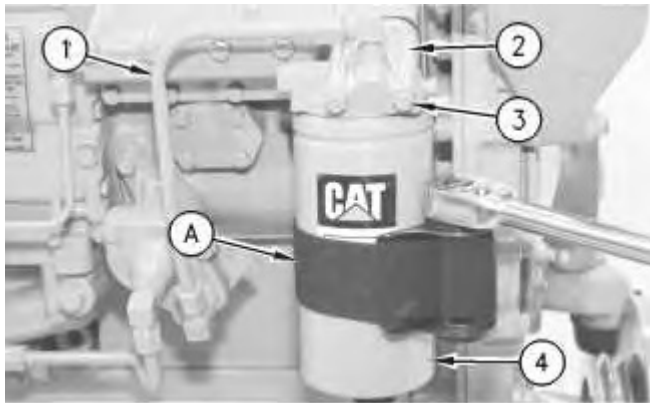

Illustration 1

g00468389

1. Use Tool (A) to remove fuel filter (4) .
2. Disconnect fuel line (1) from fuel filter base (2) .
3. Remove two bolts (3), the washers, fuel filter base (2) and the gasket from the fuel injection pump housing.

## Installation Procedure

Table 2

Required Tools			
Tool	Part Number	Part Description	Qty
A	2P-8250	Strap Wrench Assembly	1

---

### NOTICE

**Keep all parts clean from contaminants.**

**Contaminants may cause rapid wear and shortened component life.**

---

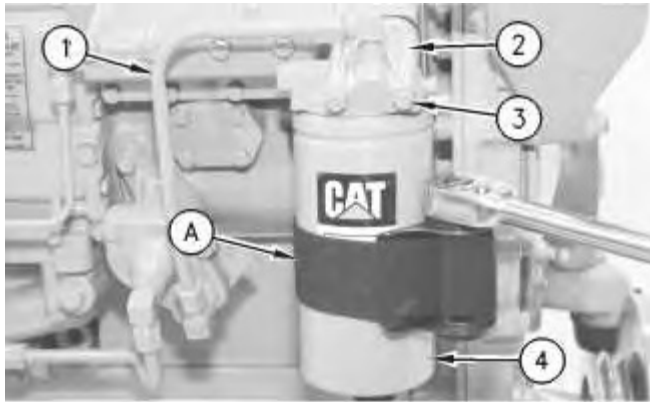

Illustration 2

g00468389

**Note:** Check the condition of the gaskets. If the gaskets are worn or damaged, use new parts for replacement.

1. Install the gasket, fuel filter base (2), the washers and two bolts (3) on the fuel injection pump housing.
2. Connect fuel line (1) to fuel filter base (2) .
3. Use Tool (A) to install fuel filter (4) .

[Previous Screen](#)

Product: EXCAVATOR

Model: 235D EXCAVATOR 8KJ

Configuration: 235D EXCAVATOR 8KJ00001-UP (MACHINE) POWERED BY 3306 ENGINE

## Disassembly and Assembly 3304B and 3306B Engines for Caterpillar Built Machines

Media Number -SEN5598-09

Publication Date -01/01/2013

Date Updated -25/01/2013

i00905874

# Fuel Transfer Pump - Remove

SMCS - 1256-011

## Removal Procedure

---

### NOTICE

**Keep all parts clean from contaminants.**

**Contaminants may cause rapid wear and shortened component life.**

---

---

### NOTICE

**Care must be taken to ensure that fluids are contained during performance of inspection, maintenance, testing, adjusting and repair of the machine. Be prepared to collect the fluid with suitable containers before opening any compartment or disassembling any component containing fluids.**

**Refer to Special Publication, NENG2500, "Caterpillar Tools and Shop Products Guide", for tools and supplies suitable to collect and contain fluids in Caterpillar machines.**

**Dispose of all fluids according to local regulations and mandates.**

---

---

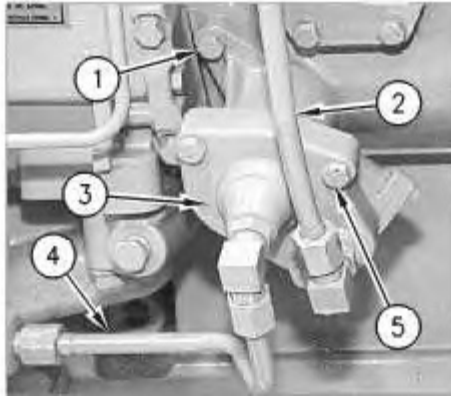

---

Illustration 1

g00462112

1. Turn the fuel supply line valve to the OFF position.
2. Remove tube assembly (2) and tube assembly (4) from fuel transfer pump (3) .
3. Remove bolts (1) and (5) from fuel transfer pump (3). Remove fuel transfer pump (3) and the O-ring seal.

[Previous Screen](#)

Product: EXCAVATOR

Model: 235D EXCAVATOR 8KJ

Configuration: 235D EXCAVATOR 8KJ00001-UP (MACHINE) POWERED BY 3306 ENGINE

## Disassembly and Assembly 3304B and 3306B Engines for Caterpillar Built Machines

Media Number -SEN5598-09

Publication Date -01/01/2013

Date Updated -25/01/2013

i01003268

# Fuel Transfer Pump - Disassemble

SMCS - 1256-015

## Disassembly Procedure

### Start By:

- A. Remove the fuel transfer pump. Refer to Disassembly and Assembly, "Fuel Transfer Pump - Remove".

---

### NOTICE

**Keep all parts clean from contaminants.**

**Contaminants may cause rapid wear and shortened component life.**

---

### NOTICE

**Care must be taken to ensure that fluids are contained during performance of inspection, maintenance, testing, adjusting and repair of the machine. Be prepared to collect the fluid with suitable containers before opening any compartment or disassembling any component containing fluids.**

**Refer to Special Publication, NENG2500, "Caterpillar Tools and Shop Products Guide", for tools and supplies suitable to collect and contain fluids in Caterpillar machines.**

**Dispose of all fluids according to local regulations and mandates.**

---

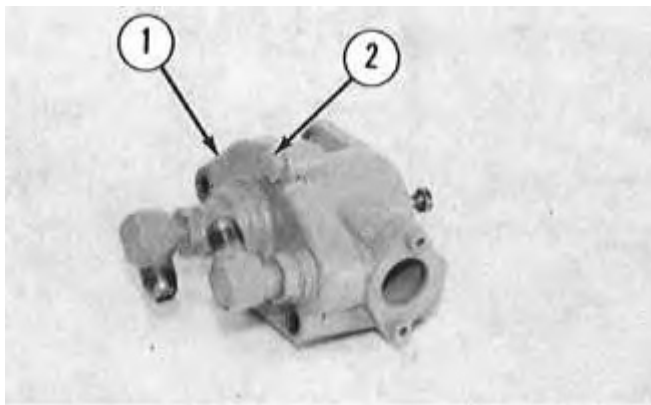

Illustration 1

g00498289

 **WARNING**

**Personal injury can result from parts and/or covers under spring pressure.**

**Spring force will be released when covers are removed.**

**Be prepared to hold spring loaded covers as the bolts are loosened.**

---

1. Remove bolts (2) and cover (1) from the fuel transfer pump housing.

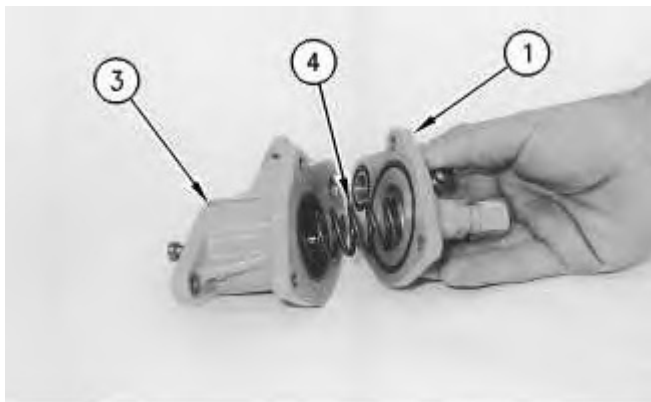

Illustration 2

g00499040

2. Remove spring (4) from housing (3) .
-

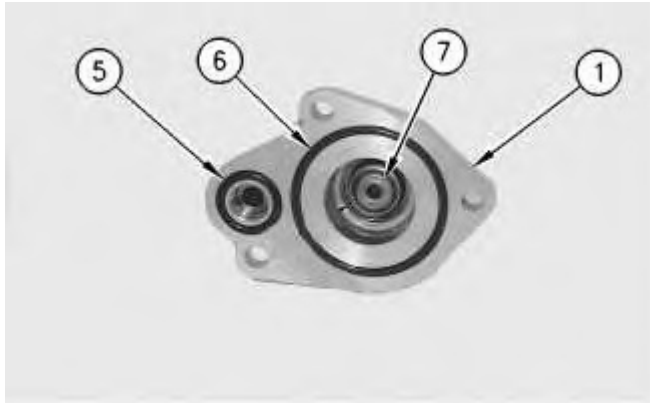

Illustration 3

g00498980

3. Remove O-ring seals (5) and (6) from cover (1) .
4. Remove valve assembly (7) from cover (1) .

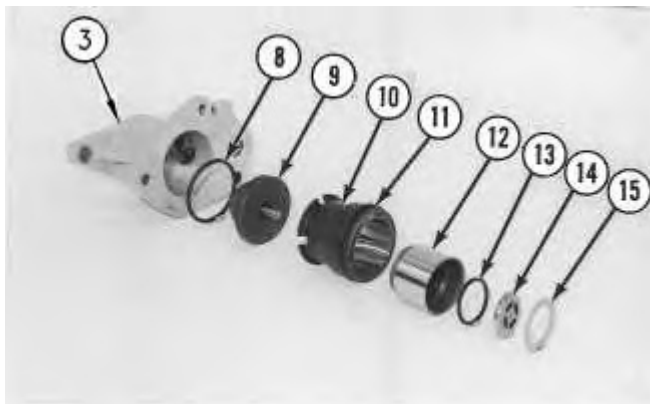

Illustration 4

g00498334

5. Remove piston (12) from sleeve (10). Remove washer (15), valve assembly (14) and seal (13) from piston (12) .
6. Remove sleeve (10) from housing (3). Remove O-ring seal (11) from sleeve (10) .
7. Remove guide and tappet assembly (9) and seal (8) from housing (3) .

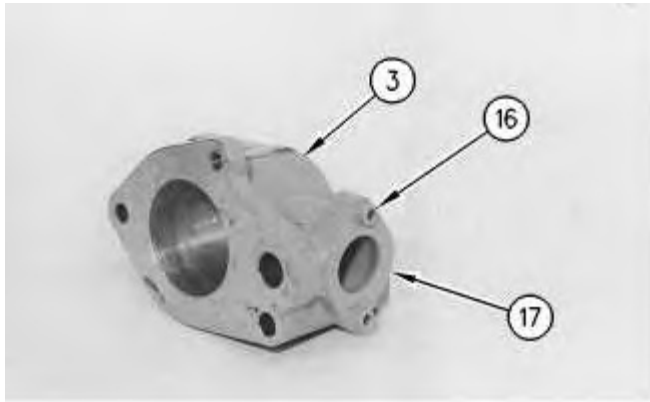

Illustration 5

g00498367

8. Remove two bolts (16), cover (17) and the seal from housing (3) .

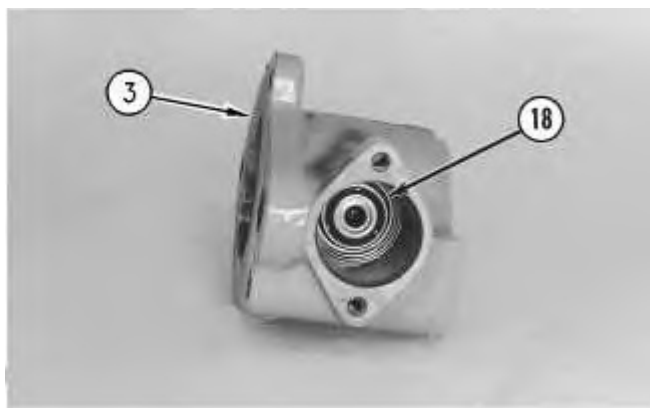

Illustration 6

g00498470

9. Remove valve assembly (18) from housing (3) .

[Previous Screen](#)

Product: EXCAVATOR

Model: 235D EXCAVATOR 8KJ

Configuration: 235D EXCAVATOR 8KJ00001-UP (MACHINE) POWERED BY 3306 ENGINE

## Disassembly and Assembly 3304B and 3306B Engines for Caterpillar Built Machines

Media Number -SEN5598-09

Publication Date -01/01/2013

Date Updated -25/01/2013

i01003269

# Fuel Transfer Pump - Assemble

SMCS - 1256-016

## Assembly Procedure

---

### NOTICE

Care must be taken to ensure that fluids are contained during performance of inspection, maintenance, testing, adjusting and repair of the machine. Be prepared to collect the fluid with suitable containers before opening any compartment or disassembling any component containing fluids.

Refer to Special Publication, NENG2500, "Caterpillar Tools and Shop Products Guide", for tools and supplies suitable to collect and contain fluids in Caterpillar machines.

Dispose of all fluids according to local regulations and mandates.

---

---

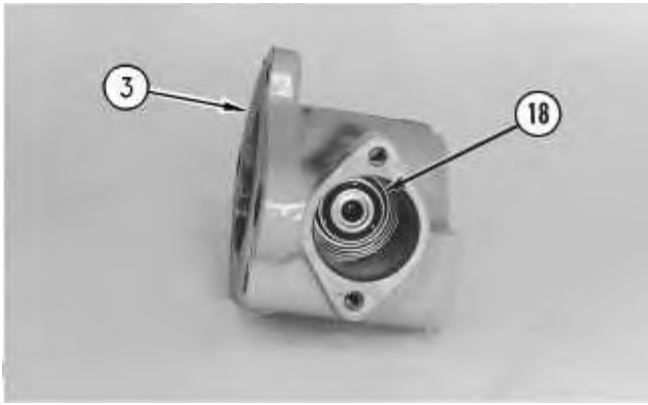

Illustration 1

g00498470

1. Install valve assembly (18) in housing (3) .

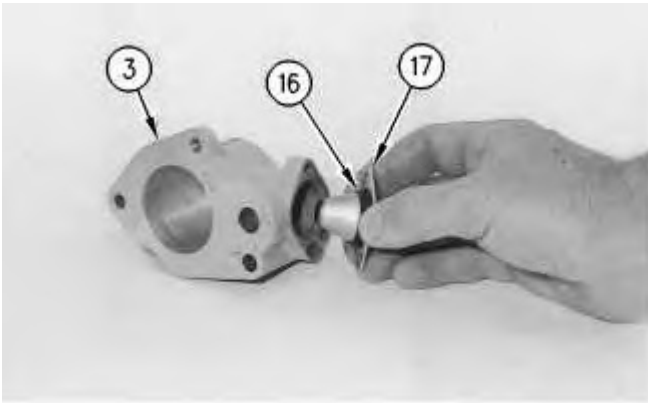

Illustration 2

g00498687

2. Put clean diesel fuel on seal (16). Install seal (16) on cover (17), as shown. Install the two bolts that hold cover (17) to housing (3) .

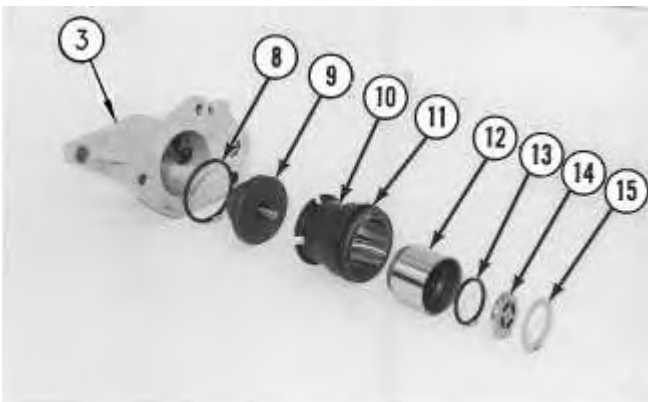

Illustration 3

g00498334

---

## NOTICE

**The tappet and guide assembly must be serviced as a unit.**

---

3. Put clean diesel fuel on seal (8). Install seal (8) on guide and tappet assembly (9). Install guide and tappet assembly (9) in housing (3) .
4. Put clean diesel fuel on O-ring seal (11). Put O-ring seal (11) in position on sleeve (10). Install sleeve (10) in housing (3) .
5. Install piston (12) in sleeve (10) .
6. Put clean diesel fuel on seal (13). Put seal (13), valve assembly (14) and washer (15) in position in piston (12) .

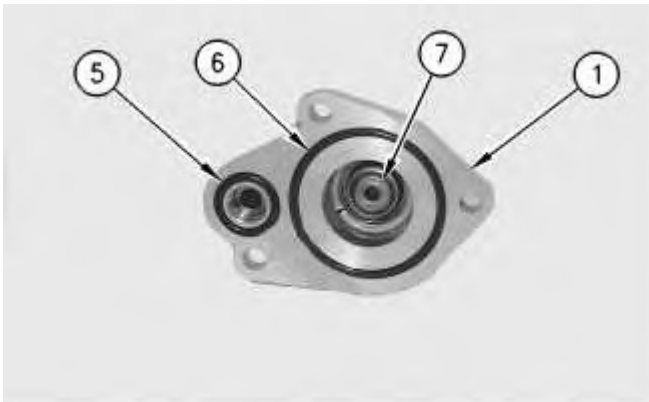
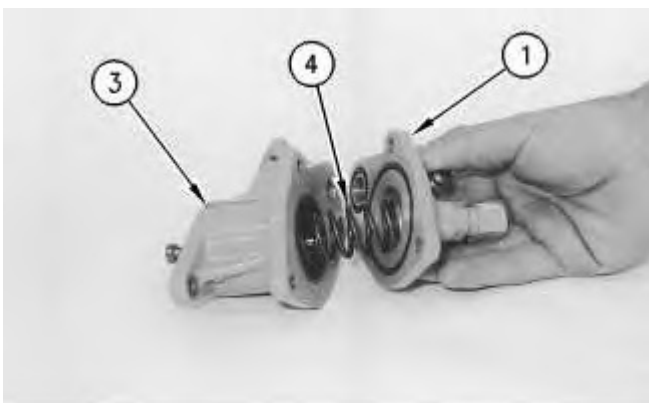

Illustration 4

g00498980

7. Put clean diesel fuel on O-ring seals (5) and (6). Install O-ring seals (5) and (6) in cover (1). Install valve assembly (7) in cover (1) .



8. Install spring (4) in housing (3) .

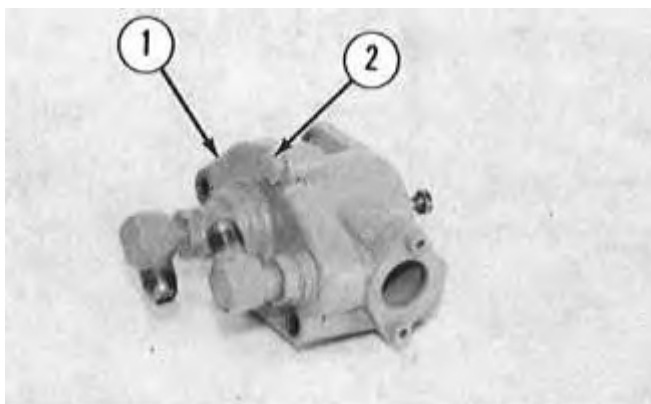

Illustration 6

g00498289

9. Put cover (1) in position on the housing and install bolts (2) that hold the cover in position.

**End By:** Install the fuel transfer pump. Refer to Disassembly and Assembly, "Fuel Transfer Pump - Install".

[Previous Screen](#)

Product: EXCAVATOR

Model: 235D EXCAVATOR 8KJ

Configuration: 235D EXCAVATOR 8KJ00001-UP (MACHINE) POWERED BY 3306 ENGINE

## Disassembly and Assembly 3304B and 3306B Engines for Caterpillar Built Machines

Media Number -SEN5598-09

Publication Date -01/01/2013

Date Updated -25/01/2013

i00906240

## Fuel Transfer Pump - Install

SMCS - 1256-012

### Installation Procedure

---

#### NOTICE

**Keep all parts clean from contaminants.**

**Contaminants may cause rapid wear and shortened component life.**

---

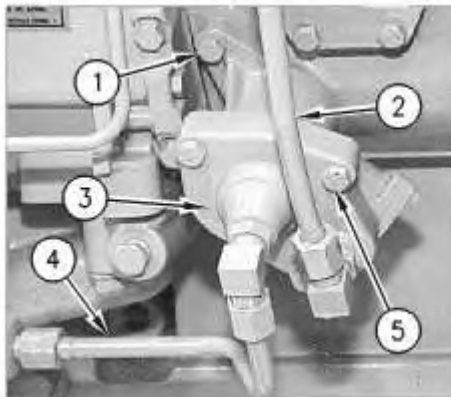

Illustration 1

g00462112

1. Install the O-ring seal and fuel transfer pump (3). Install bolts (1) and (5) .
2. Install tube assembly (2) and tube assembly (4) .

3. Turn the fuel supply line valve to the ON position.

---

[Copyright 1993 - 2019 Caterpillar Inc.](#)

Sat Sep 21 09:11:45 UTC+0800 2019

[All Rights Reserved.](#)

[Private Network For SIS Licensees.](#)

[Previous Screen](#)

Product: EXCAVATOR

Model: 235D EXCAVATOR 8KJ

Configuration: 235D EXCAVATOR 8KJ00001-UP (MACHINE) POWERED BY 3306 ENGINE

## Disassembly and Assembly 3304B and 3306B Engines for Caterpillar Built Machines

Media Number -SEN5598-09

Publication Date -01/01/2013

Date Updated -25/01/2013

i00880175

# Fuel Injection Lines - Remove and Install

SMCS - 1252-010

## Removal Procedure

---

### NOTICE

**Keep all parts clean from contaminants.**

**Contaminants may cause rapid wear and shortened component life.**

---

---

### NOTICE

**Care must be taken to ensure that fluids are contained during performance of inspection, maintenance, testing, adjusting and repair of the machine. Be prepared to collect the fluid with suitable containers before opening any compartment or disassembling any component containing fluids.**

**Refer to Special Publication, NENG2500, "Caterpillar Tools and Shop Products Guide", for tools and supplies suitable to collect and contain fluids in Caterpillar machines.**

**Dispose of all fluids according to local regulations and mandates.**

---

---

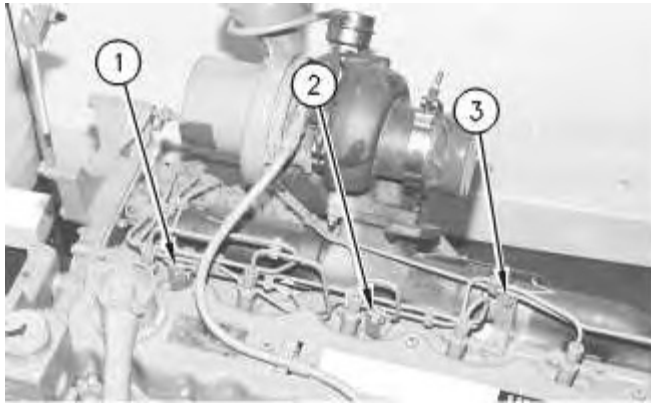

Illustration 1

g00448807

1. Remove three bolts (1), (2) and (3) and the brackets from the fuel injection lines.

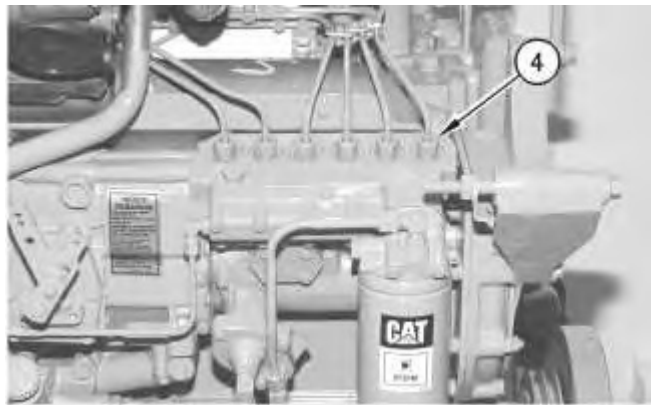

Illustration 2

g00448808

2. Disconnect six fuel injection line nuts (4) from the fuel injection pumps.

---

## NOTICE

**Do not allow the tops of the nozzles to turn while the fuel lines are loosened. The nozzles will be damaged if the top of the nozzle turns in the body. Defective fuel nozzles will damage the engine due to incorrect spray patterns.**

---



Illustration 3

g00448809

3. Hold the tops of fuel injector nozzles (5) with a wrench, as shown. Loosen the six fuel injection line nuts at fuel injector nozzles (4) .
4. Disconnect the fuel injection line nuts at the fuel injector nozzles and remove the fuel injection lines. Put caps and plugs on all openings immediately in order to prevent dirt from contaminating the fuel system.

## Installation Procedure

Table 1

Required Tools			
Tool	Part Number	Part Description	Qty
A	5P-0144	Fuel Line Socket	1

---

### NOTICE

**Keep all parts clean from contaminants.**

**Contaminants may cause rapid wear and shortened component life.**

---

### NOTICE

**Do not allow the tops of the nozzles to turn while the fuel lines are loosened. The nozzles will be damaged if the top of the nozzle turns in the body. Defective fuel nozzles will damage the engine due to incorrect spray patterns.**

---

1. Remove the protective covers from the fuel line connections. Place the fuel injection lines in position on the engine. Tighten the fuel injection line nuts on the fuel injection pump and the fuel injector nozzles finger tight.

**Note:** The nozzle assembly must be supported with a wrench.

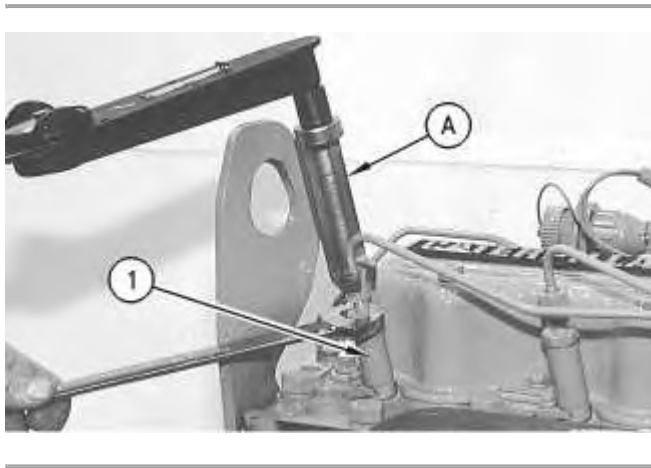

Illustration 4

g00448810

2. Hold the tops of fuel injector nozzles (1) and use Tool (A) in order to tighten the fuel injection line nuts to a torque of  $40 \pm 7 \text{ N}\cdot\text{m}$  ( $30 \pm 5 \text{ lb ft}$ ).

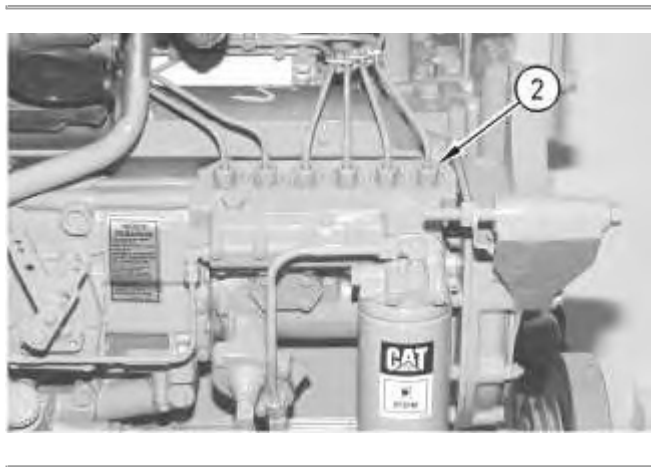
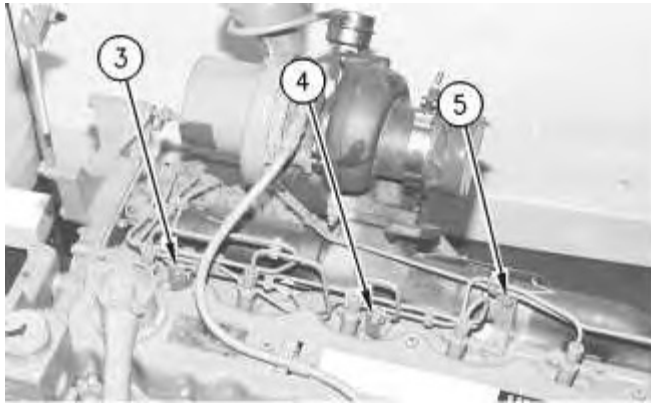

Illustration 5

g00475542

3. Tighten six fuel injection line nuts (2) at the fuel injection pumps to a torque of  $40 \pm 7 \text{ N}\cdot\text{m}$  ( $30 \pm 5 \text{ lb ft}$ ).
-



---

Illustration 6

g00475546

4. Install the brackets and three bolts (3), (4) and (5) that hold the fuel injection lines in position.
5. Prime the fuel system. Refer to the Operation and Maintenance Manual, "Fuel System - Prime" topic (Maintenance Section).

Previous Screen

Product: EXCAVATOR

Model: 235D EXCAVATOR 8KJ

Configuration: 235D EXCAVATOR 8KJ00001-UP (MACHINE) POWERED BY 3306 ENGINE

**Disassembly and Assembly  
3304B and 3306B Engines for Caterpillar Built Machines**

Media Number -SEN5598-09

Publication Date -01/01/2013

Date Updated -25/01/2013

i01048513

## Fuel Injection Nozzles - Remove

SMCS - 1254-011

### Removal Procedure

Table 1

Required Tools			
Tool	Part Number	Part Description	Qty
A	6V-6980	Fuel Nozzle Puller	1
B	FT-1533	Adapter	1
	1P-0074	Slide Hammer Puller	1

**Start By:**

- A. Remove the fuel injection lines. Refer to Disassembly and Assembly, "Fuel Injection Lines - Remove and Install".

---

**NOTICE**

**Keep all parts clean from contaminants.**

**Contaminants may cause rapid wear and shortened component life.**

---



---

**NOTICE**

**Do not allow the tops of the fuel injector nozzles to turn while the fuel lines are loosened. The fuel injector nozzles will be damaged if the tops of the fuel injector nozzle turns in the body. Defective fuel injector nozzles will damage the engine due to incorrect spray patterns.**

---

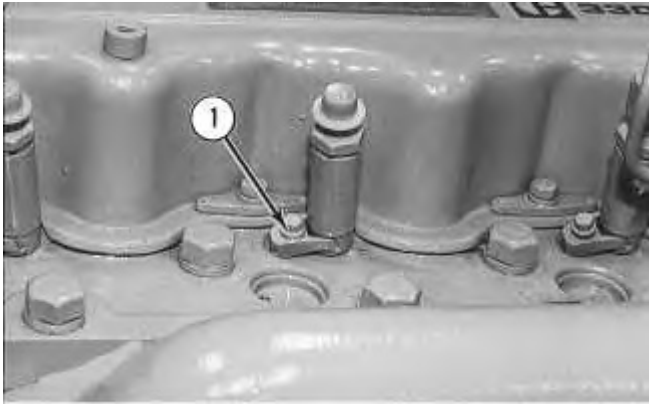

Illustration 1

g00448820

1. Remove bolt (1) and the clamp that secures the fuel injector nozzle.

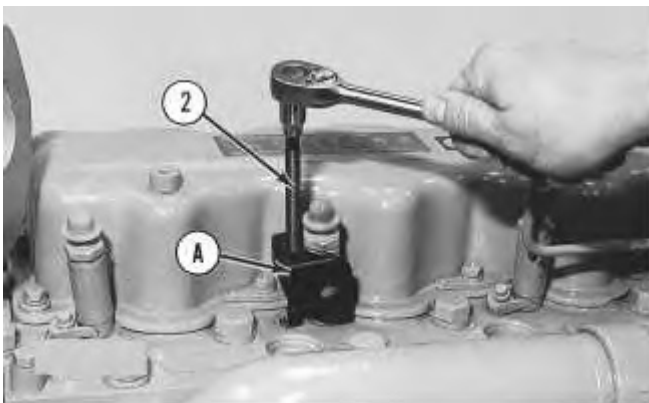

Illustration 2

g00448821

2. Install Tool (A) over the fuel injector nozzle. Turn screw (2) counterclockwise until the button on the end of the screw is just above the bolt hole for the clamp that holds down the fuel injector nozzle.
  3. Tilt Tool (A) upward so that the inside lip of the fuel nozzle puller is under the diameter of the fuel injector nozzle.
  4. Turn screw (2) clockwise until the button on Tool (A) goes into the bolt hole for the clamp that holds down the fuel injector nozzle.
-

## NOTICE

**Do not exceed the recommended torque on the screw of the 6V-6980 Fuel Nozzle Puller in order to remove the nozzle. The nozzle will bend or break if a torque greater than 17 N·m (13 lb ft) is applied.**

---

5. Turn screw (2) clockwise in order to lift the fuel injector nozzle out of the bore. After the fuel injector nozzle is loose in the bore of the cylinder head, move the fuel injector nozzle upward and move the fuel injector nozzle downward. Moving the fuel injector nozzle helps to loosen any carbon buildup and aids in the removal of the fuel injector nozzle.
6. When Tool (A) is used to remove the fuel injector nozzles, remove the carbon dam seal on the end of the fuel injector nozzle.

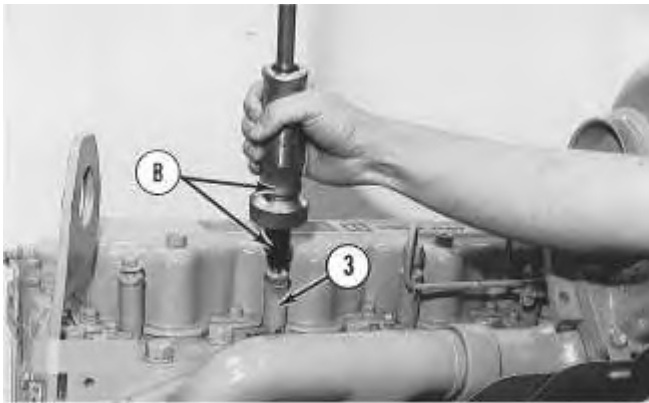

Illustration 3

g00448822

7. If the fuel injector nozzle cannot be removed with Tool (A), Tool (B) must be used.

**Note:** When Tool (B) is used, it is likely that the fuel injector nozzle cannot be used again. A new fuel injector nozzle will need to be installed as a replacement.

**Note:** Align the centerline of Tool (B) with the extended centerline of fuel injector nozzle (3). This procedure will help prevent distortion of the fuel injector nozzle which can cause the fuel injector nozzle to bend or break.

8. Remove the protective cap and install Tool (B) .
9. Use the slide hammer in order to remove fuel injector nozzle (3) .
10. Remove the compression seal from the fuel injector nozzle.

[Previous Screen](#)

Product: EXCAVATOR

Model: 235D EXCAVATOR 8KJ

Configuration: 235D EXCAVATOR 8KJ00001-UP (MACHINE) POWERED BY 3306 ENGINE

## Disassembly and Assembly 3304B and 3306B Engines for Caterpillar Built Machines

Media Number -SEN5598-09

Publication Date -01/01/2013

Date Updated -25/01/2013

i01048591

# Fuel Injection Nozzles - Install

SMCS - 1254-012

## Installation Procedure

Table 1

Required Tools			
Tool	Part Number	Part Description	Qty
A	6V-4979	Carbon Seal Installation Tool	1
B	8S-2245	Injector Cleaning Tool	1
C	6V-4089	Reamer	1

---

### NOTICE

**Keep all parts clean from contaminants.**

**Contaminants may cause rapid wear and shortened component life.**

---



**Suggest:**

**If the above button click is invalid.**

**Please download this document**

**first, and then click the above link**

**to download the complete manual.**

**Thank you so much for reading**

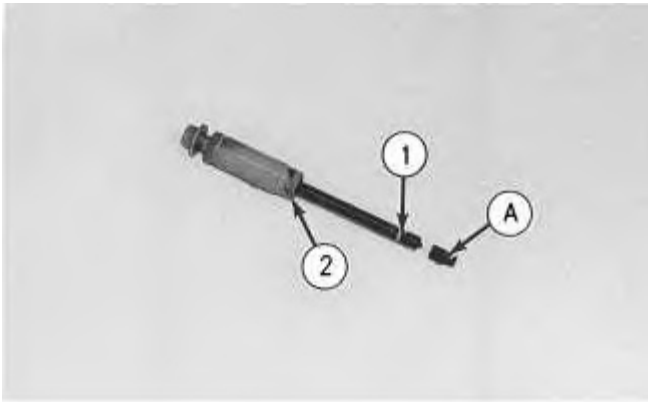

Illustration 1

g00448903

1. Put carbon dam seal (1) on the small end of Tool (A). Expand carbon dam seal (1) by sliding carbon dam seal (1) to the large end of Tool (A). Put Tool (A) against the fuel injector nozzle. Slide carbon dam seal (1) from Tool (A) to the fuel injector nozzle. Slide carbon dam seal (1) into position in the groove of the fuel injector nozzle, as shown. Use Tool (A) in order to install carbon dam seal (1).
2. To clean the fuel injector nozzles, refer to Special Instruction, SEHS7292 for the use of Tool (B) .
3. Install a new compression seal (2) on the fuel injector nozzle.



Illustration 2

g00448904

4. Use Tool (C) in order to clean the bore in the cylinder head for the fuel injector nozzle. Use a wrench in order to turn Tool (C) .

**<https://www.ebooklibonline.com>**

Hello dear friend!

Thank you very much for reading.

Enter the link into your browser.

The full manual is available for immediate download.

**<https://www.ebooklibonline.com>**