



Service Repair Manual

Models

120M Motor Grader

		Bolt M8 - 1.25 by 460mm	
M	8B-7548	Push-Puller Tool Gp	1
N	2P-8312	Retaining Ring Pliers	1
P	1P-2321	Combination Puller	1
	1P-0510	Driver Gp	1
R	189-0408	Shackle As	1
	3E-3882	Eyebolt	1
S	126-7175	Push-Puller Tool Gp	1
	4C-5653	Threaded Adapter	1
	1P-0510	Driver Gp	1

Start By:

- a. Remove the transmission.

NOTICE

Care must be taken to ensure that fluids are contained during performance of inspection, maintenance, testing, adjusting, and repair of the product. Be prepared to collect the fluid with suitable containers before opening any compartment or disassembling any component containing fluids.

Refer to Special Publication, NENG2500, "Dealer Service Tool Catalog" for tools and supplies suitable to collect and contain fluids on Cat[®] products.

Dispose of all fluids according to local regulations and mandates.

NOTICE

Keep all parts clean from contaminants.

Contaminants may cause rapid wear and shortened component life.

Note: Put identification marks on all harness assemblies for installation purposes.

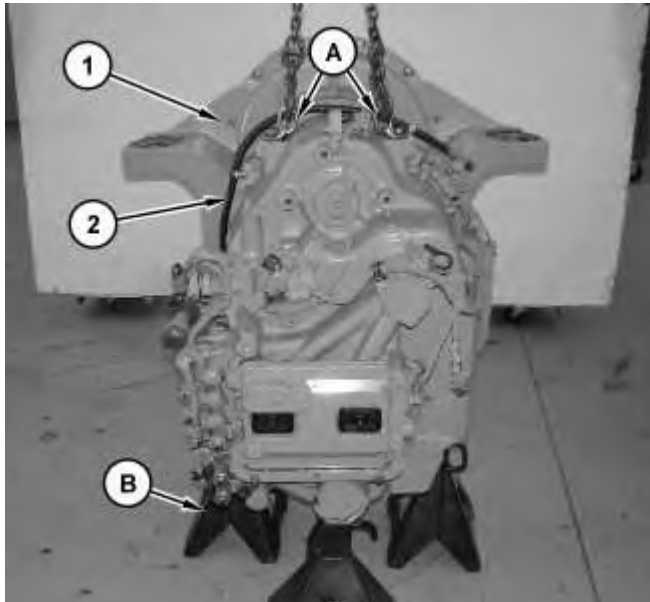

Illustration 1

g01386565

1. Attach Tooling (A) and a suitable lifting device to transmission (1). The weight of transmission (1) is approximately 862 kg (1900 lb). Use Tooling (A) and the suitable lifting device to position transmission (1) onto Tooling (B). Remove hose assembly (2).



Illustration 2

g01386568

2. Remove bolts (3) to remove control module (4) and spacers (5).

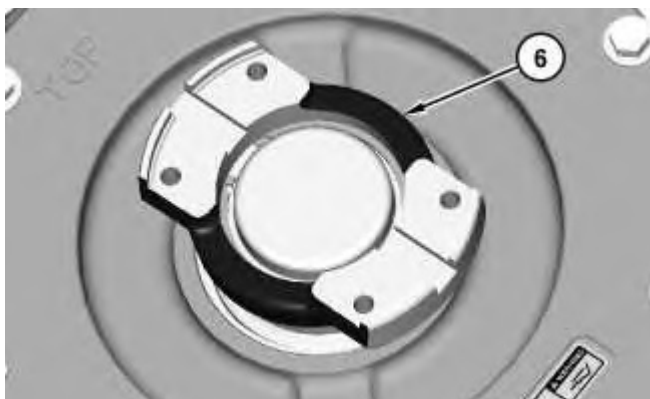

<https://www.ebooklibonline.com>

Hello dear friend!

Thank you very much for reading.

Enter the link into your browser.

The full manual is available for immediate download.

<https://www.ebooklibonline.com>

3. Remove yoke assembly (6).
-



4. Remove retaining ring (7).
 5. Remove cup (8). Remove O-ring seal (9).
-

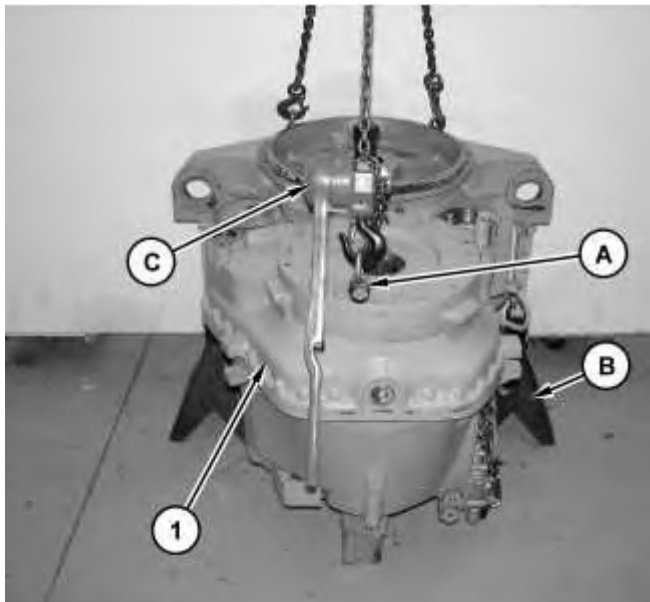

6. Attach Tooling (A), Tooling (C), and a suitable lifting device to transmission (1). Use Tooling (A), Tooling (C), and the suitable lifting device to position transmission (1) onto Tooling (B) and suitable cribbing. Position transmission (1) with the output shaft upward.
-

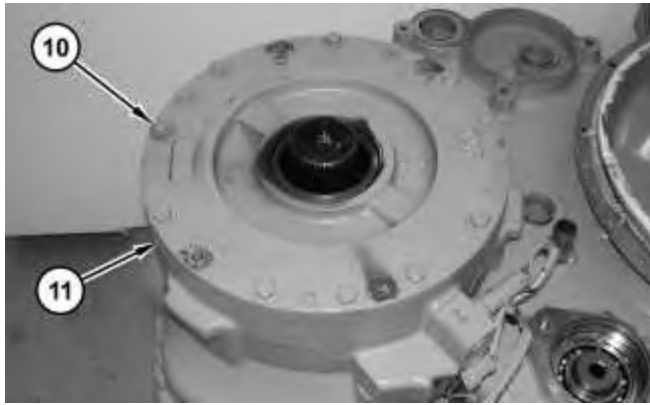

Illustration 6

g01386585

! WARNING

Personal injury can result from being struck by parts propelled by a released spring force.

Make sure to wear all necessary protective equipment.

Follow the recommended procedure and use all recommended tooling to release the spring force.

-
7. Remove bolts (10) to remove plate assembly (11).

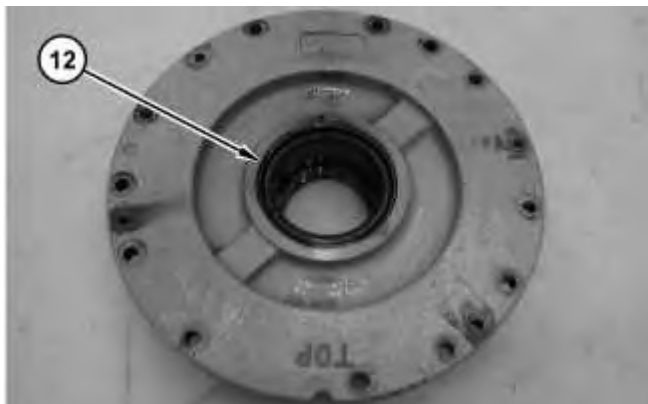

Illustration 7

g01386589

-
8. Remove lip seal (12).
-

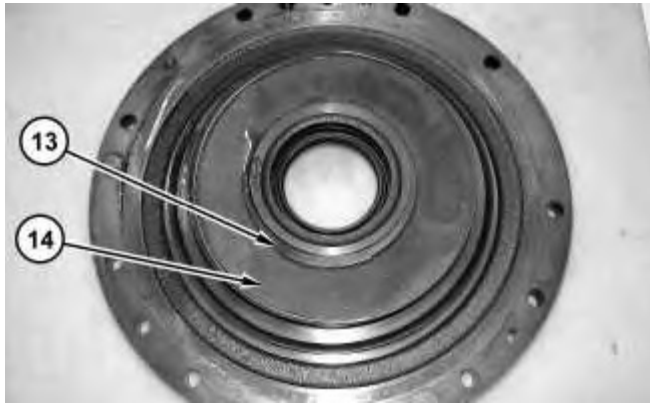

Illustration 8

g01386599

9. Use Tooling (D) to remove retaining ring (13). Remove coned disc springs (14).

Note: Note the orientation of coned disc springs (14) for assembly purposes.

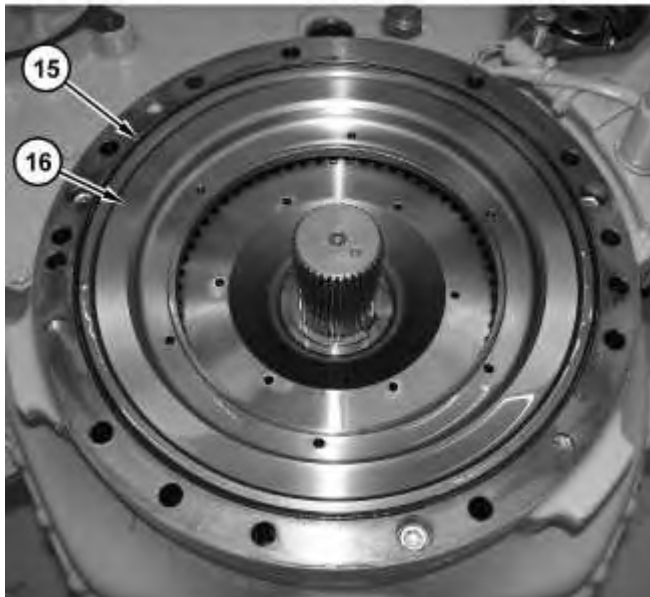

Illustration 9

g01386610

10. Remove O-ring seal (15) and piston (16).



Illustration 10

g01386621

11. Remove piston seal (17). Remove piston seal (18).
-

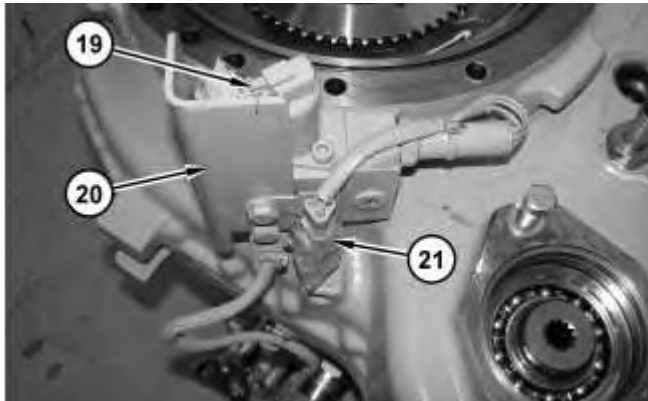

Illustration 11

g01386624

12. Disconnect harness assembly (19) and harness assembly (21). Remove guard (20).
-



Illustration 12

g01386632

13. Remove bolts (22). Use two people to remove housing (23). The weight of housing (23) is approximately 20 kg (45 lb).
-

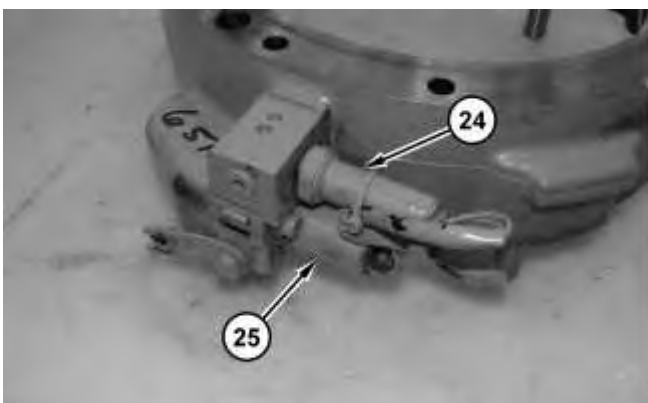

14. Remove pressure sensor (24) and the O-ring seal. Remove solenoid (25).



Illustration 14

15. Remove O-ring seal (26), O-ring seal (27), O-ring seal (28), O-ring seal (29), and O-ring seal (30).



Illustration 15

16. Remove seal (31).



Illustration 16

17. Remove friction discs (32) and clutch plates (33).

Note: Note the quantity and the order of friction discs (32) and clutch plates (33) for assembly purposes.

18. Remove O-ring seals (34) and dowels (35).

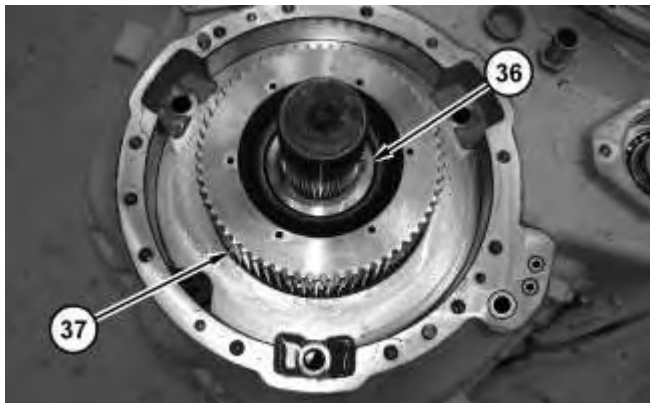

Illustration 17

g01386675

19. Remove retaining ring (36). Remove hub (37).

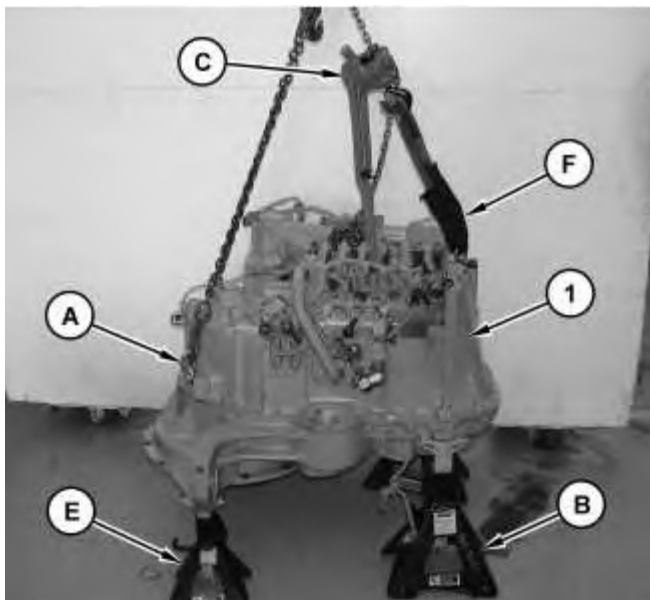

Illustration 18

g01386684

20. Attach Tooling (A), Tooling (C), Tooling F, and a suitable lifting device to transmission (1). Use Tooling (A), Tooling (C), Tooling (F), and the suitable lifting device to position transmission (1) onto Tooling (B) and Tooling (E) with the output shaft downward. The weight of transmission (1) is approximately 862 kg (1900 lb).
-

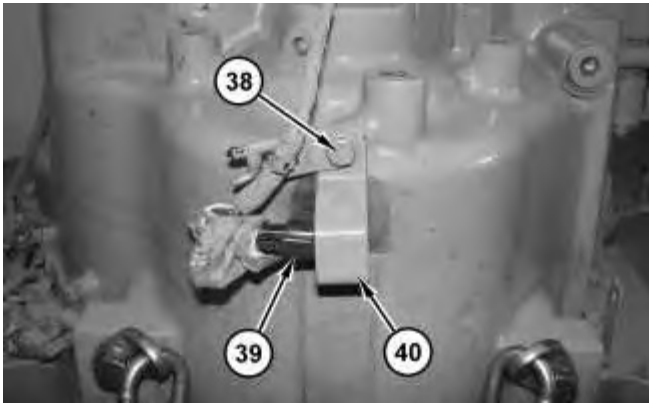

Illustration 19

g01386730

21. Remove bolt (38) to remove speed sensor (39) and guard (40).

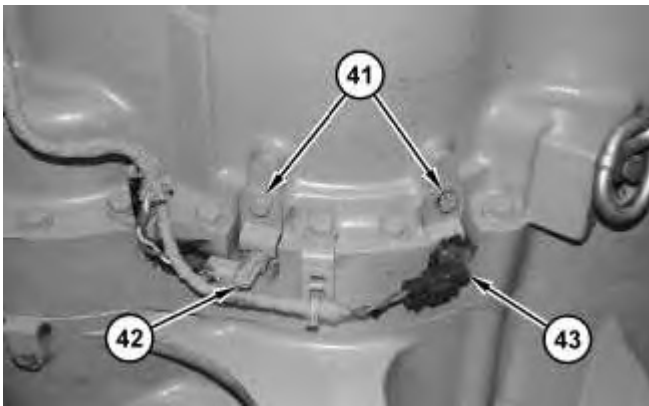

Illustration 20

g01386747

22. Remove bolts (41) to remove speed sensor (42) and speed sensor (43).

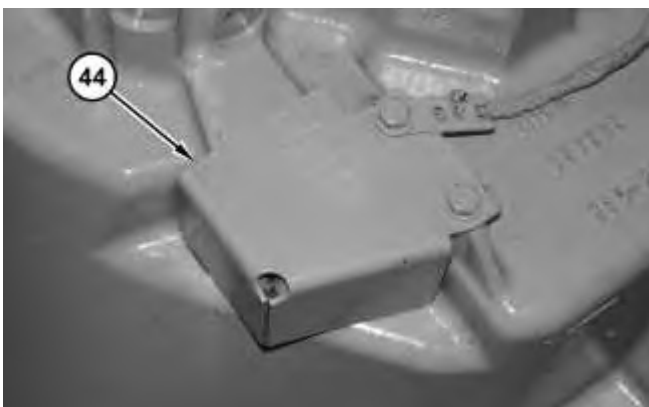

Illustration 21

g01386749

23. Remove cover (44).

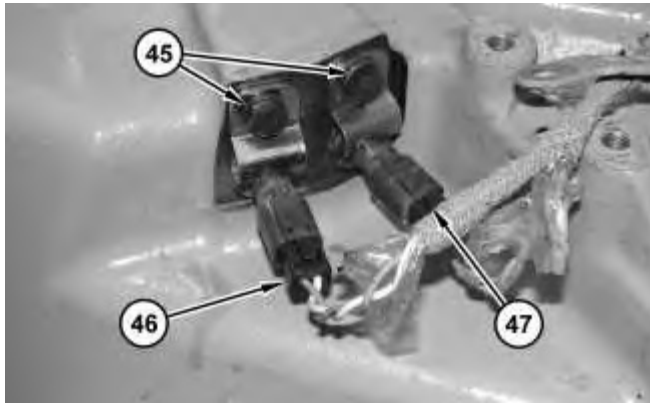

Illustration 22

g01386757

24. Remove bolts (45) to remove speed sensor (46) and speed sensor (47).

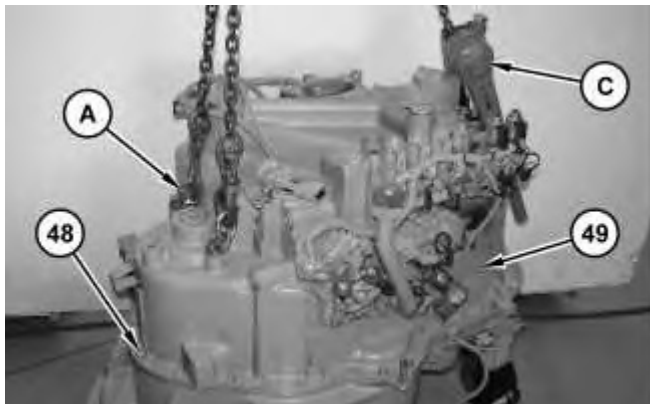

Illustration 23

g01386764

25. Attach Tooling (A), Tooling (C), and a suitable lifting device to housing (49). The weight of housing (49) is approximately 136 kg (300 lb). Remove bolts (48).
26. Use Tooling (A), Tooling (C), and the suitable lifting device to remove housing (49).

Note: If necessary, use Tooling (G) to assist in removal of housing (49).

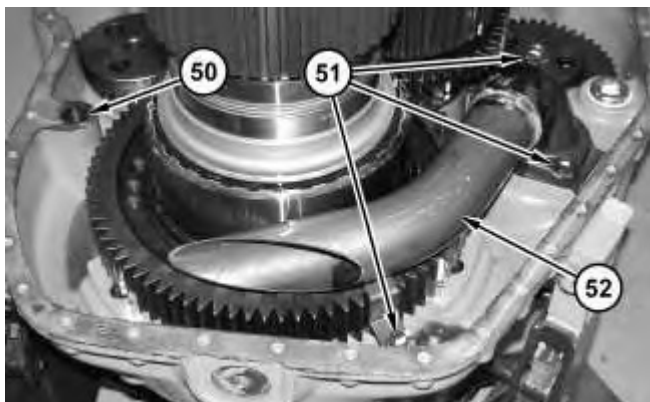

Illustration 24

g01386792

27. Remove O-ring seal (50). Remove bolts (51) and the locks. Remove tube assembly (52) and the O-ring seal.

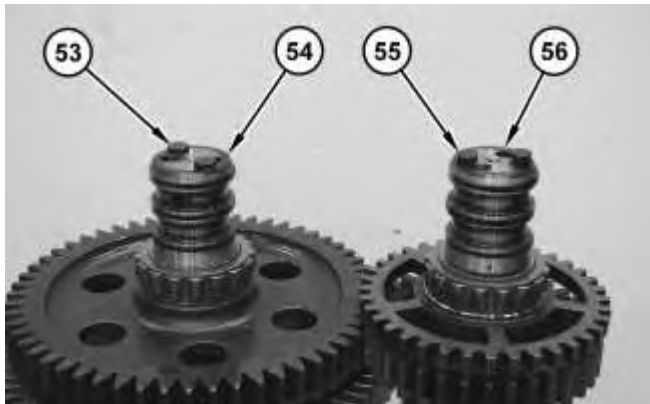

Illustration 25

g01386795

28. Remove bolts (53) to remove seal carrier (54). Remove bolts (55) to remove seal carrier (56).

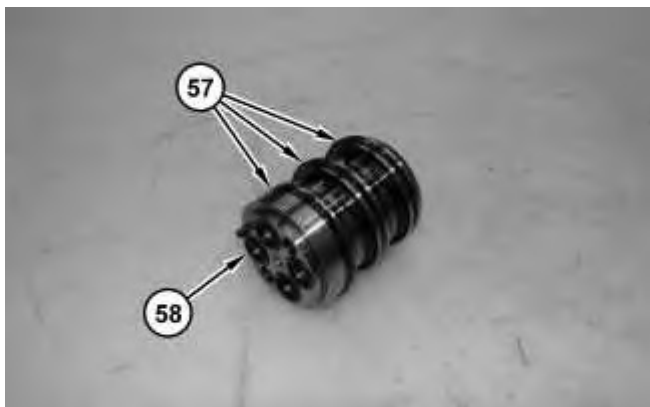

Illustration 26

g01386797

29. Remove seal rings (57). Remove O-ring seals (58). Repeat this step for the remaining seal carrier.

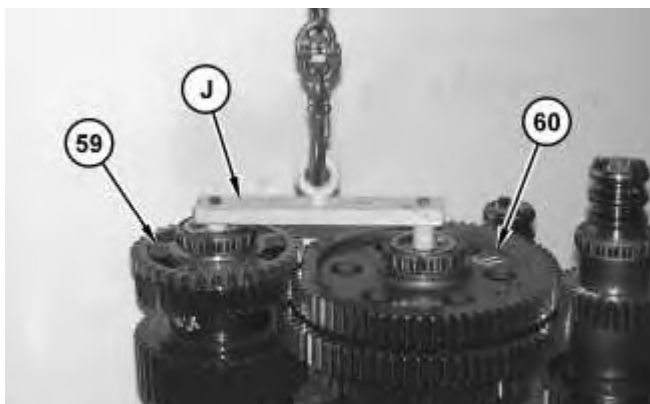

Illustration 27

g01386811

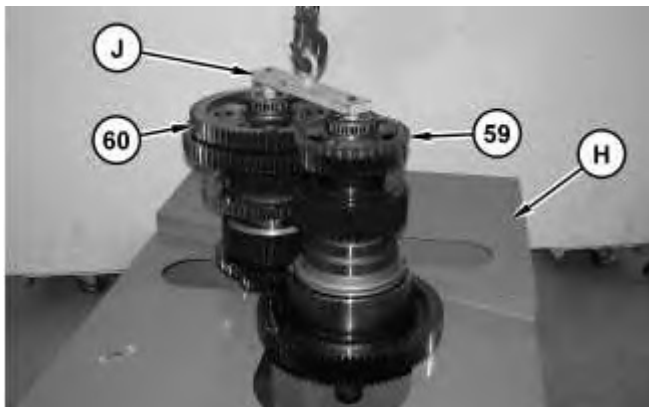

Illustration 28

g01386815

30. Use Tooling (J) and a suitable lifting device to remove clutch assembly (59) and clutch assembly (60). The combined weight of clutch assembly (59) and clutch assembly (60) is approximately 163 kg (360 lb).
31. Position clutch assembly (59) and clutch assembly (60) onto Tooling (H). If necessary, support clutch assembly (60) with suitable cribbing.
32. Remove Tooling (J) to separate clutch assembly (59) from clutch assembly (60).

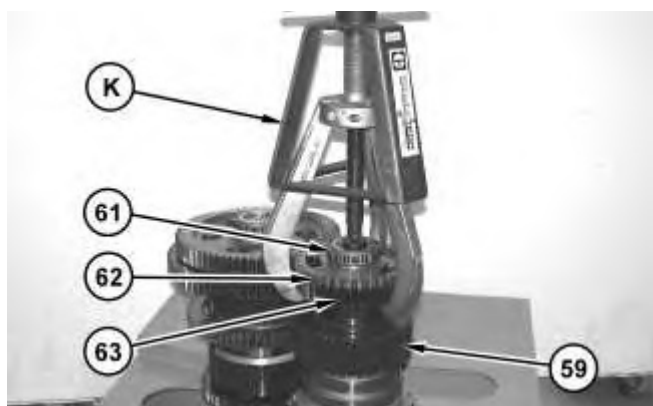

Illustration 29

g01386827

33. Use Tooling (K) to remove bearing (61) and rotor (62) from clutch assembly (59).

Note: Be sure to attach Tooling (K) to gear assembly (63) to prevent damage to rotor (62).

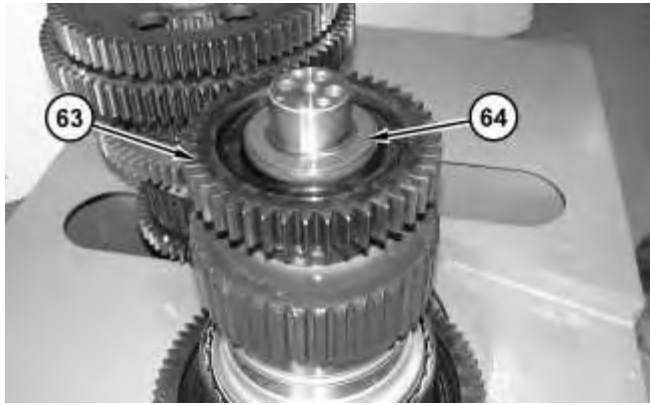

Illustration 30

g01386841

34. Remove thrust washer (64) and gear assembly (63).

Note: Note the orientation of thrust washer (64) for assembly purposes.



Illustration 31

g01386992

35. Remove bearing sleeves (65) from gear assembly (63).



Illustration 32

g01386993

36. Remove thrust washer (66).

Note: Note the orientation of thrust washer (66) for assembly purposes.

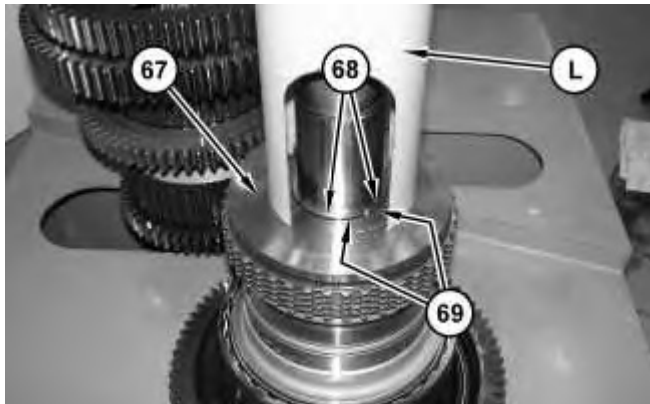

Illustration 33

g01386997

WARNING

Personal injury can result from being struck by parts propelled by a released spring force.

Make sure to wear all necessary protective equipment.

Follow the recommended procedure and use all recommended tooling to release the spring force.

37. Use Tooling (L) to compress hub assembly (67). Remove lock rings (68) and two half rings (69) (not shown).

Note: Note the orientation of lock rings (68) and two ring halves (69) for assembly purposes.

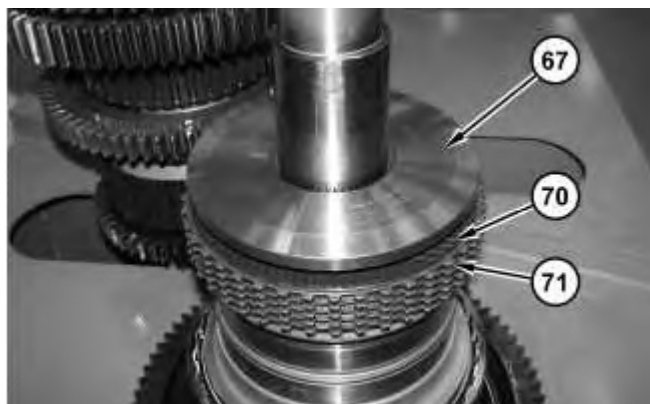

Illustration 34

g01387088

38. Remove hub assembly (67), friction discs (70), and clutch plates (71).

Note: Note the order of friction discs (70) and clutch plates (71) for assembly purposes.



Illustration 35

g01387093

39. Remove wave spring (72) and piston (73).



Illustration 36

g01387119

40. Remove seal rings (74) and (75) from piston (73).

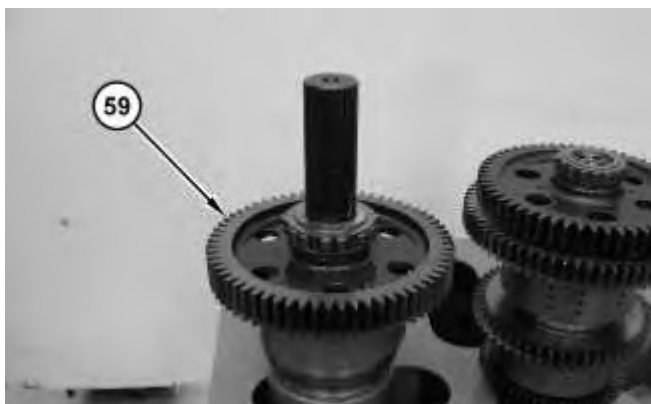

Illustration 37

g01387137

41. Use a suitable lifting device to turn over clutch assembly (59). The weight of clutch assembly (59) is approximately 59 kg (130 lb).

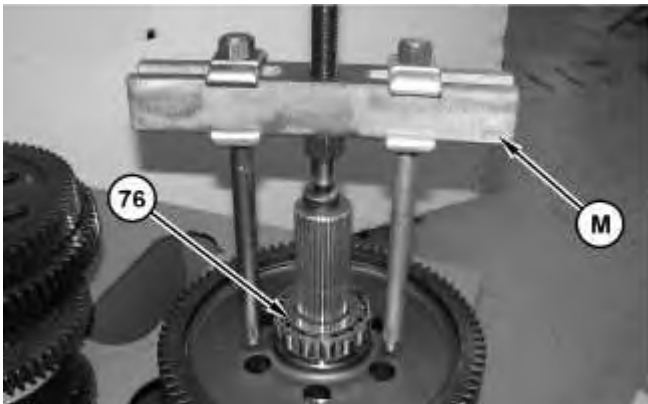

Illustration 38

g01387150



Illustration 39

g01387221

! WARNING

Personal injury can result from being struck by parts propelled by a released spring force.

Make sure to wear all necessary protective equipment.

Follow the recommended procedure and use all recommended tooling to release the spring force.

-
42. Use Tooling (M) to remove bearing (76). Remove thrust washer (77), thrust disc (78), and gear assembly (79).

Note: Note the orientation of thrust disc (78) for assembly purposes.

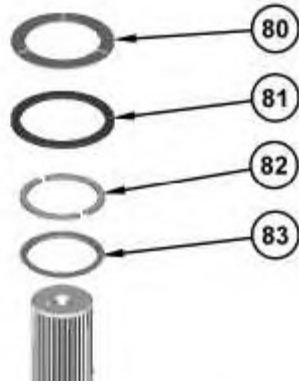

Illustration 40

g01387228

43. Remove thrust disc (80), washer (81), half rings (82), and lock rings (83).

Note: Note the orientation of thrust disc (80) for assembly purposes.

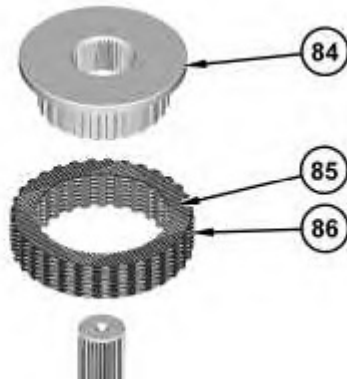
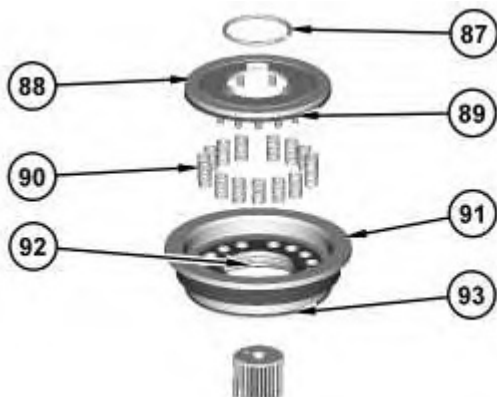

Illustration 41

g01387232

44. Remove hub assembly (84). Remove friction discs (85) and clutch plates (86).

Note: Note the orientation of friction discs (85) and clutch plates (86) for assembly purposes.



45. Use Tooling (N) to remove retaining ring (87).
46. Remove balance piston (88). Remove seal ring (89) from balance piston (88).
47. Remove springs (90).
48. Remove piston (91). Remove seal rings (92) and (93) from piston (91).



Illustration 43

49. Use Tooling (K) to remove inner bearing (94) from clutch assembly (60). Remove thrust disc (95) and gear (96).

Note: Note the orientation of thrust disc (95) for assembly purposes.



Illustration 44

50. Remove thrust disc (97) and gear assembly (98) from clutch assembly (60).

Note: Note the orientation of thrust disc (97) for assembly purposes.



Illustration 45

g01387526

51. Remove sleeve bearing (99) from gear assembly (98).
-

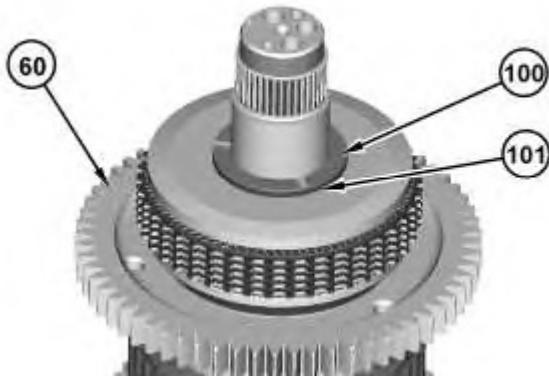

Illustration 46

g01387528

52. Remove thrust disc (100) and washer (101) from clutch assembly (60).

Note: Note the orientation of thrust disc (100) for assembly purposes.

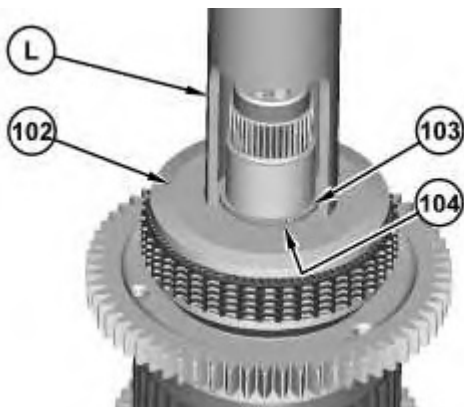

Illustration 47

g01387541

WARNING

Personal injury can result from being struck by parts propelled by a released spring force.

Make sure to wear all necessary protective equipment.

Follow the recommended procedure and use all recommended tooling to release the spring force.

53. Use Tooling (L) to compress hub assembly (102). Remove lock rings (103) and two half rings (104) (not shown).

Note: Note the orientation of lock rings (103) and two ring halves (104) for assembly purposes.



Illustration 48

g01387556

54. Remove hub assembly (102), friction discs (105), and clutch plates (106) from clutch assembly (60).

Note: Note the orientation of friction discs (105) and clutch plates (106) for assembly purposes.

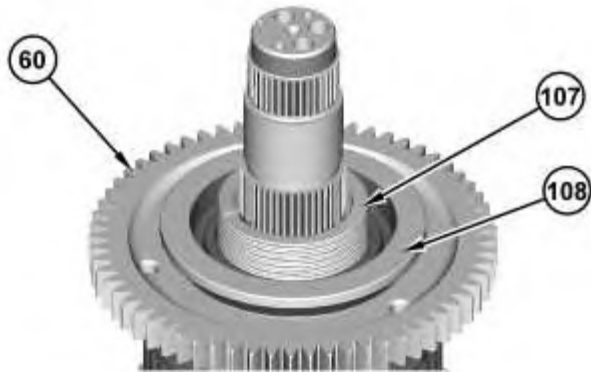

Illustration 49

g01387573

55. Remove wave spring (107) and piston (108) from clutch assembly (60).

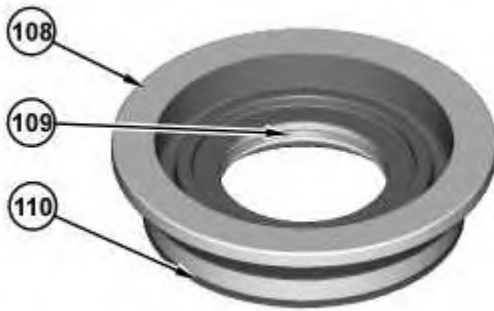

Illustration 50

g01387580

56. Remove seal rings (109) and (110) from piston (108).

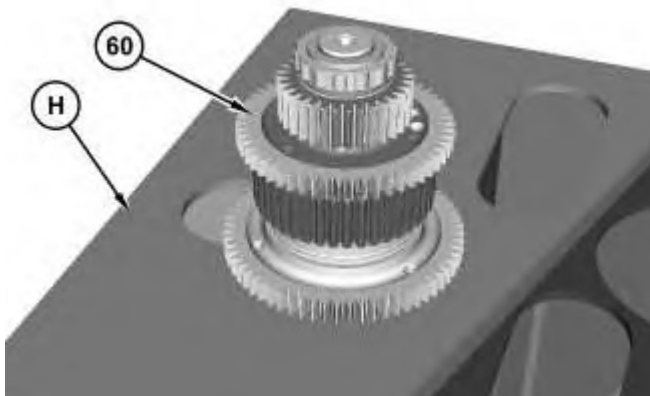

Illustration 51

g01387592

57. Use a suitable lifting device to turn over clutch assembly (60) onto Tooling (H). The weight of clutch assembly (60) is approximately 54 kg (120 lb).

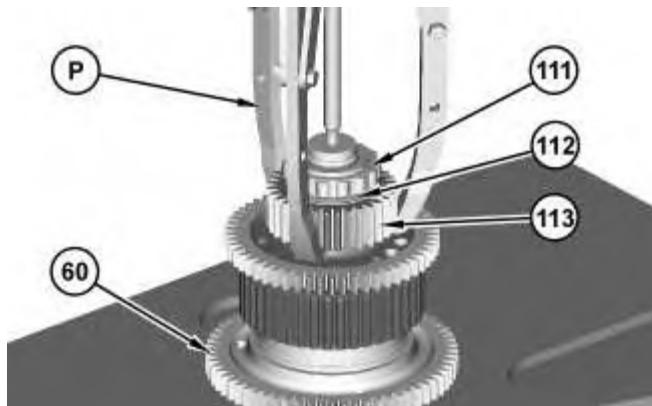

Illustration 52

g01387595

58. Use Tooling (P) to remove inner bearing (111), thrust disc (112), and gear (113) from clutch assembly (60).

Note: Note the orientation of thrust disc (112) for assembly purposes.

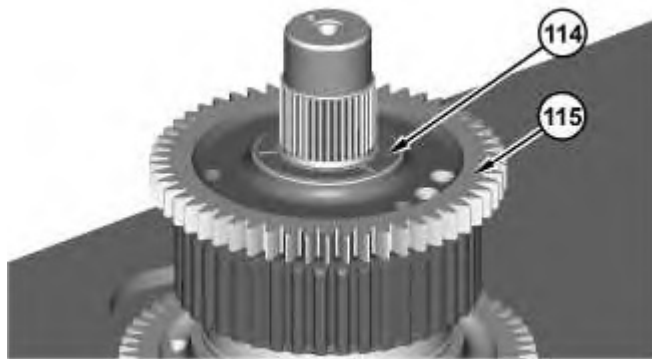

Illustration 53

g01387755

59. Remove thrust disc (114) and gear assembly (115).

Note: Note the orientation of thrust disc (114) for assembly purposes.



60. Remove bearing (116) from gear assembly (115).

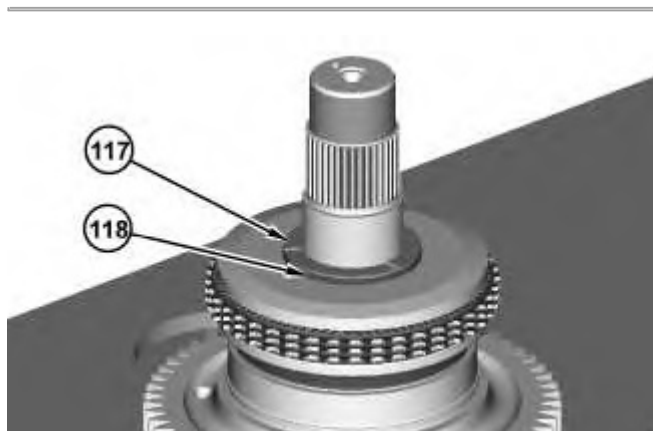

Illustration 55

61. Remove thrust disc (117) and washer (118).

Note: Note the orientation of thrust disc (117) for assembly purposes.

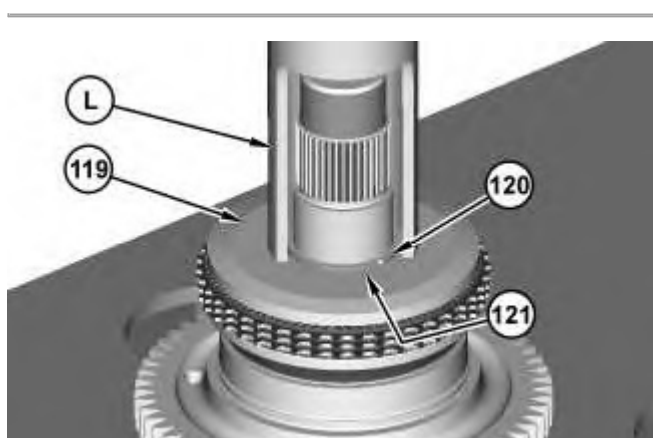

Illustration 56



Personal injury can result from being struck by parts propelled by a released spring force.

Make sure to wear all necessary protective equipment.

Follow the recommended procedure and use all recommended tooling to release the spring force.

62. Use Tooling (L) to compress hub assembly (119). Remove lock rings (120) and two half rings (121) (not shown).

Note: Note the orientation of lock rings (120) and two ring halves (121) for assembly purposes.

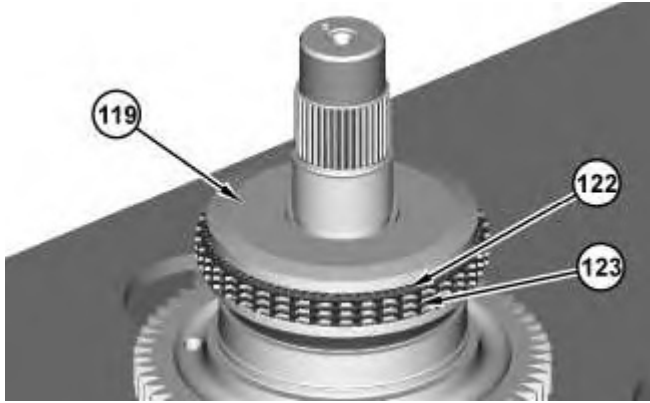

Illustration 57

g01387846

63. Remove hub assembly (119), friction discs (122), and clutch plates (123).

Note: Note the orientation of friction discs (122) and clutch plates (123) for assembly purposes.

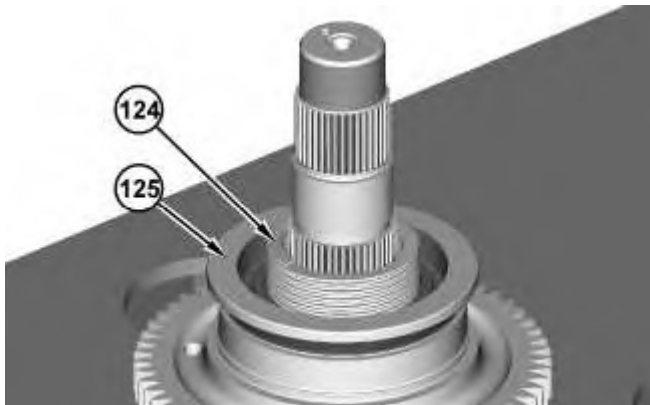

Illustration 58

g01387852

64. Remove wave spring (124) and piston (125).
-

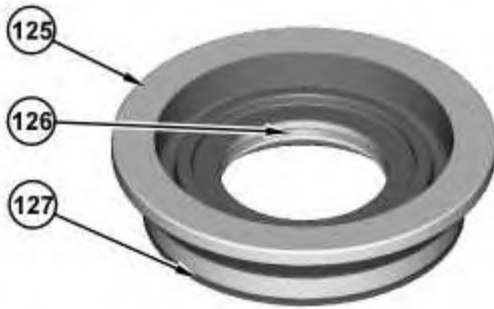

Illustration 59

g01387858

65. Remove seal rings (126) and (127) from piston (125).



Illustration 60

g01387876

66. Use Tooling (P) to remove inner bearing (128) and gear (129) from input shaft assembly (130). This is necessary at this time so that you can remove the remaining two clutch assemblies.

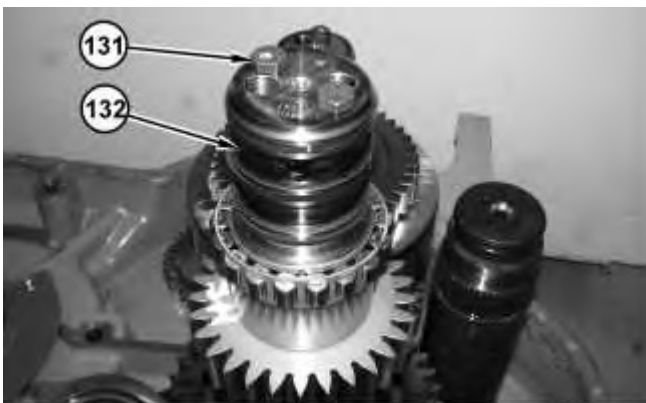

Illustration 61

g01387884

67. Remove bolts (131) to remove seal carrier (132).
-



Suggest:

If the above button click is invalid.

Please download this document first, and then click the above link to download the complete manual.

Thank you so much for reading



Illustration 62

g01387892

68. Remove seal rings (133). Remove O-ring seals (134).

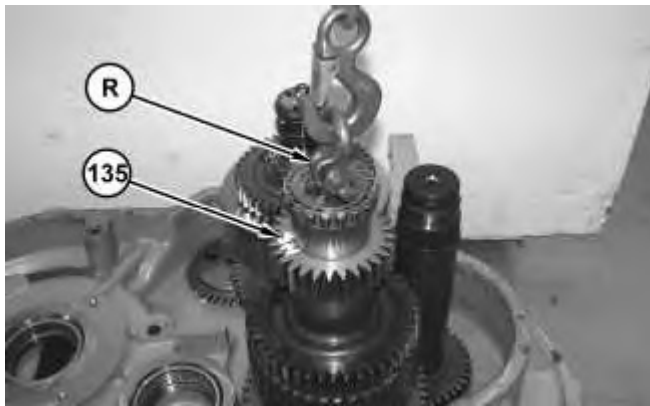

Illustration 63

g01387895

69. Attach Tooling (R) and a suitable lifting device to clutch assembly (135). The weight of clutch assembly (135) is approximately 61 kg (135 lb). Use Tooling (R) and the suitable lifting device to remove clutch assembly (135). Position clutch assembly (135) onto Tooling (H).

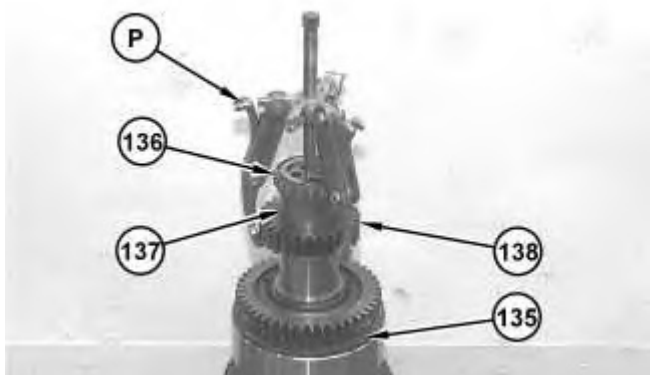

Illustration 64

g01387898

<https://www.ebooklibonline.com>

Hello dear friend!

Thank you very much for reading.

Enter the link into your browser.

The full manual is available for immediate download.

<https://www.ebooklibonline.com>