



# Service Repair Manual

## **Models**

D250E II Articulated Truck

---

[Previous Screen](#)

Product: ARTICULATED TRUCK

Model: D250E II ARTICULATED TRUCK 4PS

Configuration: D250E Series II Articulated Truck 4PS00001-UP (MACHINE) POWERED BY 3306 Engine

## Disassembly and Assembly

### D250E Series II and D300E Series II Articulated Trucks Machine Systems

Media Number -SEN9129-01

Publication Date -01/09/2004

Date Updated -21/09/2004

i01017349

## Piston Pump (Steering) - Disassemble

SMCS - 5070-015-ZH

### Disassembly Procedure

Table 1

Required Tools			
Tool	Part Number	Part Description	Qty
A	1P-0510	Driver Group	1
B	1P-1854	Pliers	1
C	1P-1857	Pliers	1

#### Start By:

- A. Remove the piston pump (steering). Refer to Disassembly and Assembly, "Piston Pump (Steering) - Remove". The information is in this manual.

---

### NOTICE

Care must be taken to ensure that fluids are contained during performance of inspection, maintenance, testing, adjusting and repair of the machine. Be prepared to collect the fluid with suitable containers before opening any compartment or disassembling any component containing fluids.

Refer to Special Publication, NENG2500, "Caterpillar Tools and Shop Products Guide", for tools and supplies suitable to collect and contain fluids in Caterpillar machines.

Dispose of all fluids according to local regulations and mandates.

- 
1. Apply alignment marks on all mating components for assembly purposes.

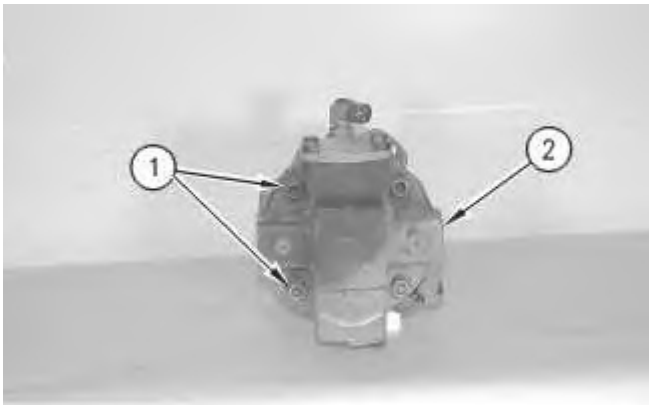

Illustration 1

g00521840

2. Remove four bolts (1) that secure pump head (2) to the pump assembly. The head is under spring tension. Remove the bolts slowly.

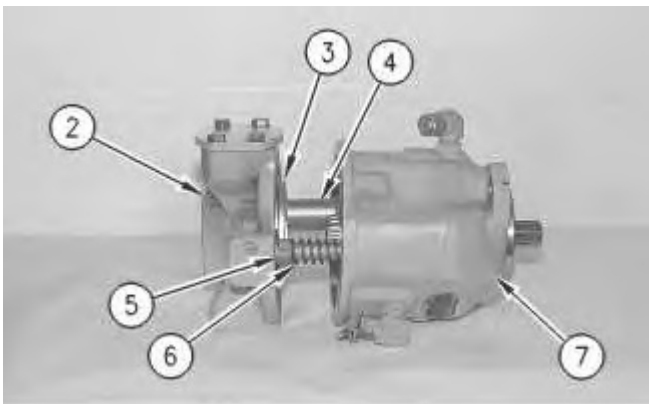

Illustration 2

g00521841

3. Remove pump head (2), plate (3), piston (4), plunger (5) and spring (6) as a unit from pump housing (7) .
-

**<https://www.ebooklibonline.com>**

Hello dear friend!

Thank you very much for reading.

Enter the link into your browser.

The full manual is available for immediate download.

**<https://www.ebooklibonline.com>**

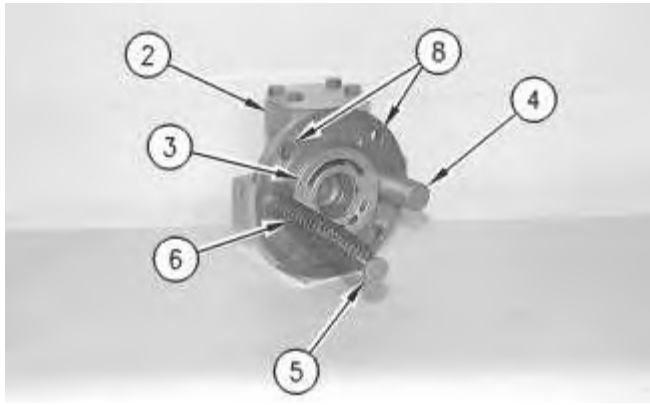

Illustration 3

g00521842

4. Remove plunger (5), spring (6), four O-ring seals (8), piston (4) and plate (3) from pump head (2) .

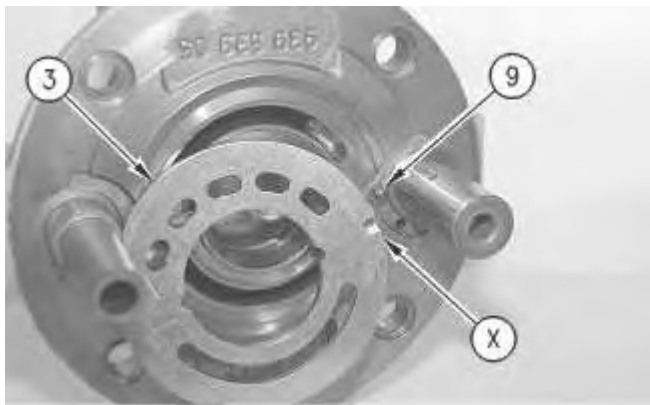
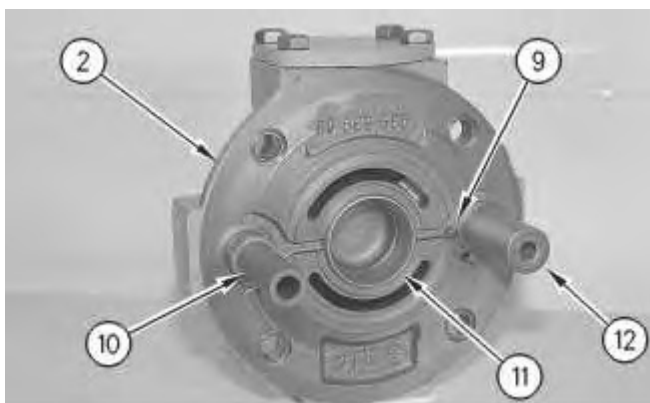

Illustration 4

g00521843

5. Plate (3) has been turned over by 180 degrees. Note the location of slot (X) that is in plate (3) for assembly purposes. Slot (X) will be positioned over locating pin (9) when plate (3) is installed to the pump head.



6. Cylinder (10) and guide (12) will not be removed from the head. If either cylinder (10) or guide (12) are damaged pump head (2) must be replaced. Remove pin (9) from pump head (2). Remove bearing cone (11) from pump head (2) .

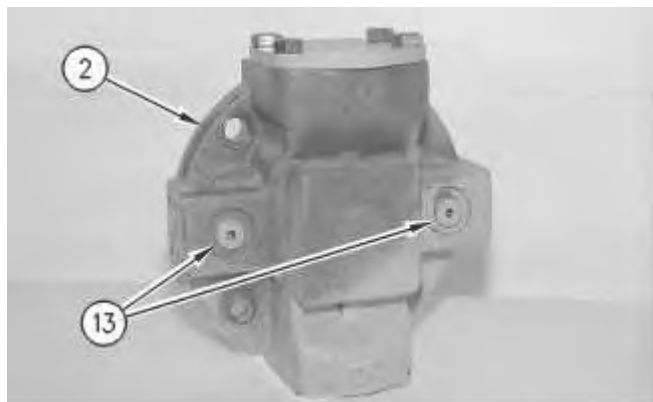

Illustration 6

7. Remove plugs (13) from pump head (2). Remove the O-ring seals from plugs (13) .

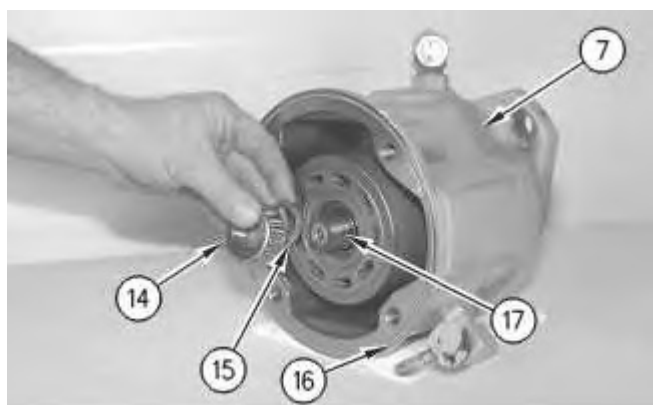

Illustration 7

8. Remove roller bearing (14) and spacer (15) from shaft (17). Remove O-ring seal (16) from pump housing (7) .
-

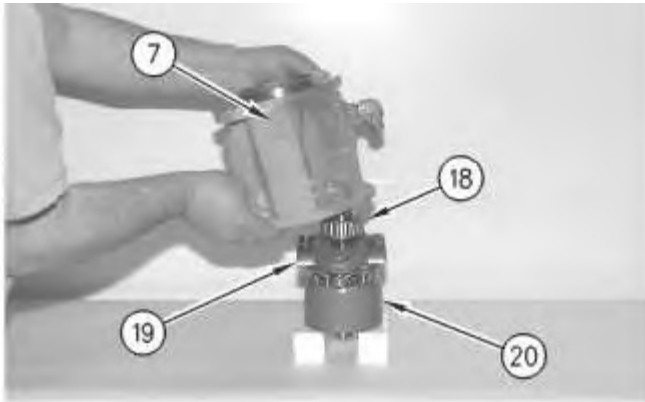

Illustration 8

g00521847

9. Turn the pump body over 180 degrees and hold the components in the pump body. Remove pump housing (7) from bearing (18), shaft (17), swashplate (19) and rotating group (20) .

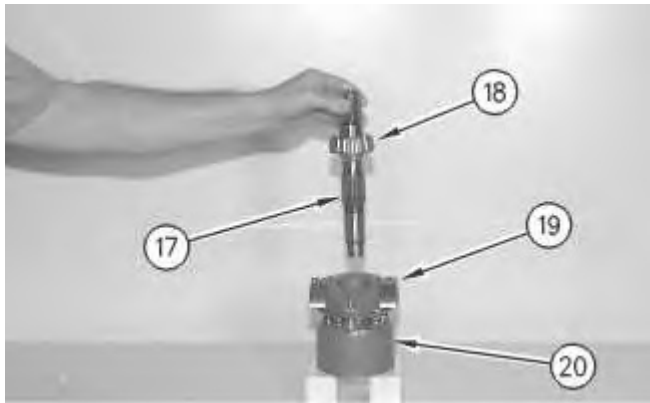

Illustration 9

g00521848

10. Remove shaft (17) and bearing (18) from swashplate (19) and rotating group (20) .

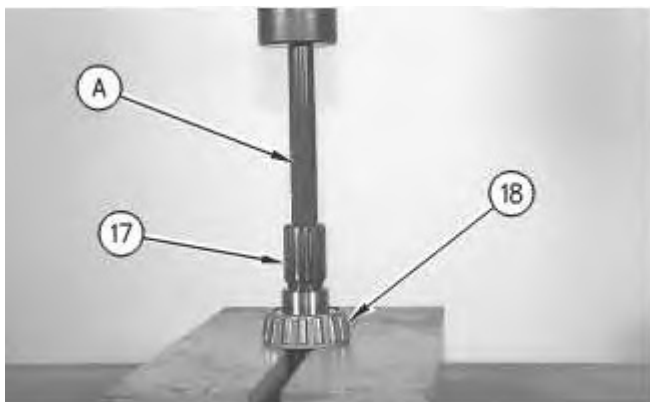

Illustration 10

g00521856

11. Use Tooling (A) and a hydraulic press in order to remove shaft (17) from roller bearing (18) .

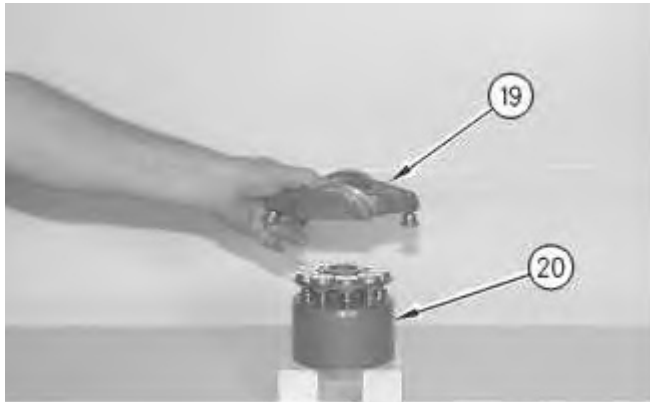

Illustration 11

g00521849

12. Remove swashplate (19) from rotating group (20) .

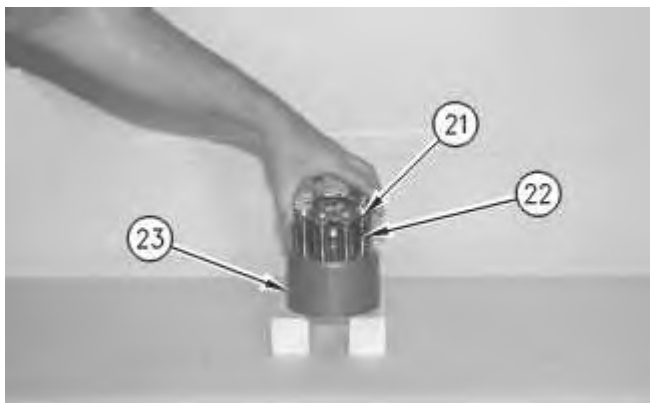

Illustration 12

g00521850

13. Apply identification marks to retraction plate (21), pistons (22) and body (23) for assembly purposes. The pistons must be installed in the original location in retraction plate (21) and in body (23). All three components must be assembled to the original alignment.
-

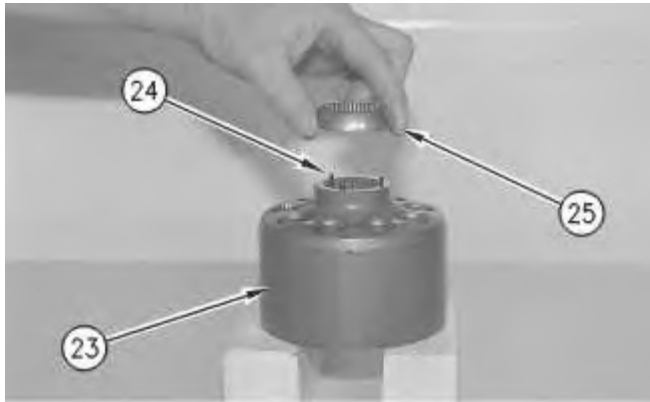

Illustration 13

g00521851

14. Remove collar bearing (25) from pins (24) and body (23) .

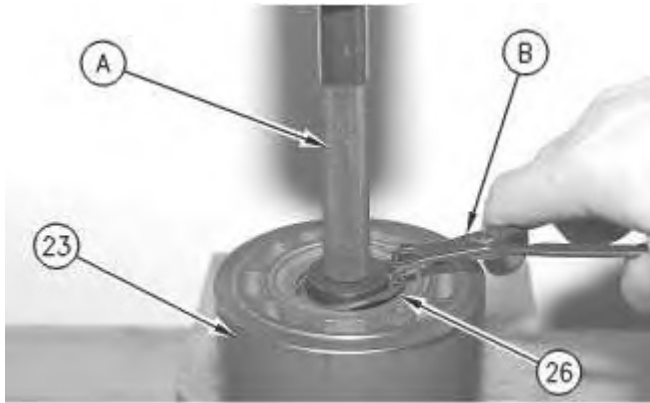

Illustration 14

g00521852

15. Place body (23) in a hydraulic press. Use Tooling (A) in order to depress the spring that is in body (23). Use Tooling (B) in order to remove retaining ring (26) that secures the spring in body (23). Slowly release the pressure from the spring and remove Tooling (A) from the assembly.



16. Remove retaining ring (26) and spring (27) from body (23) .

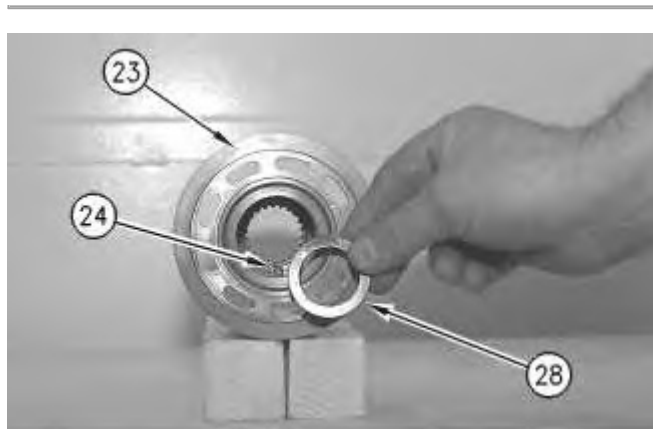

Illustration 16

17. Remove seat (28) that was under spring (27) from body (23). Remove pins (24) from body (23) .



Illustration 17

18. Remove brass bearings (29) from pump housing (7) .
-

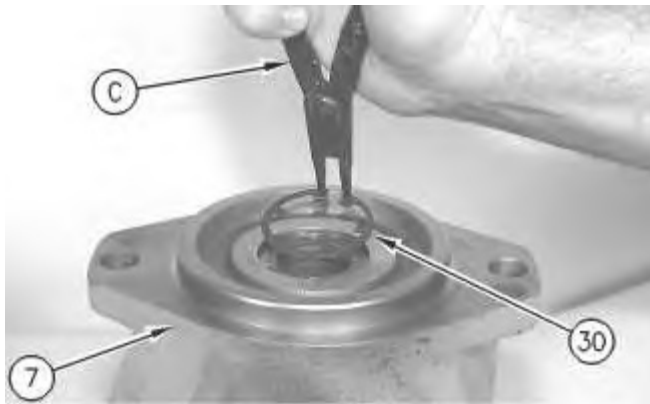

Illustration 18

g00521858

19. Use Tooling (C) in order to remove retaining ring (30) from pump housing (7) .

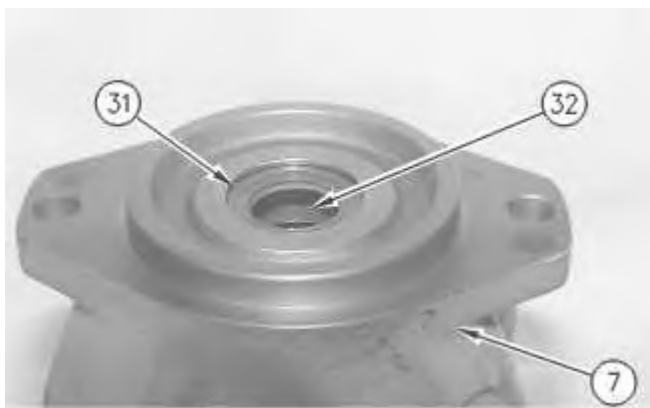

Illustration 19

g00521859



Illustration 20

g00521860

20. Lip seal (31) and bearing cone (32) will be removed from pump housing (7) together.

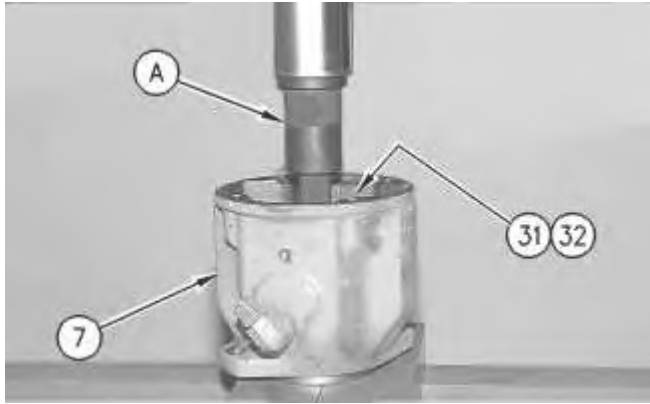

Illustration 21

g00521855

21. Use Tooling (A) in order to remove lip seal (31) and bearing cone (32) from pump housing (7) together.

[Previous Screen](#)

Product: ARTICULATED TRUCK

Model: D250E II ARTICULATED TRUCK 4PS

Configuration: D250E Series II Articulated Truck 4PS00001-UP (MACHINE) POWERED BY 3306 Engine

## Disassembly and Assembly

### D250E Series II and D300E Series II Articulated Trucks Machine Systems

Media Number -SEN9129-01

Publication Date -01/09/2004

Date Updated -21/09/2004

i07432494

## Piston Pump (Steering) - Assemble

SMCS - 5070-016-ZH

### Assembly Procedure

Table 1

Required Tools			
Tool	Part Number	Part Description	Qty
A	1P-0510	Driver Group	1
B	1P-1854	Pliers	1
C	1P-1857	Pliers	1
D	-	Loctite LB 8632 Silicone Lubricant <sup>(1)</sup>	-
	-	Loctite LB 8104 Silicone Lubricant <sup>(2)</sup>	-
	-	Loctite LB 8801 Silicone Lubricant <sup>(3)</sup>	-
	-	Loctite LB Superlube <sup>(4)</sup>	-

<sup>(1)</sup> North America

<sup>(2)</sup> EAME

<sup>(3)</sup> Asia Pacific Division

<sup>(4)</sup> South America

1. Inspect all parts and clean all parts. If any parts are worn or damaged, use new Caterpillar parts for replacement.
-

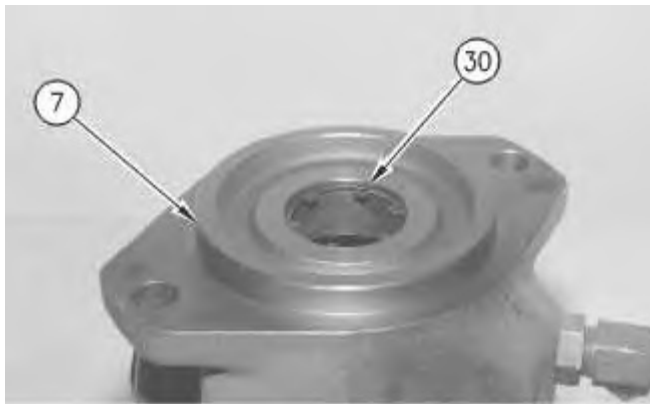

Illustration 1

g00521877

2. Use Tooling (C) to install retaining ring (30) to pump housing (7).

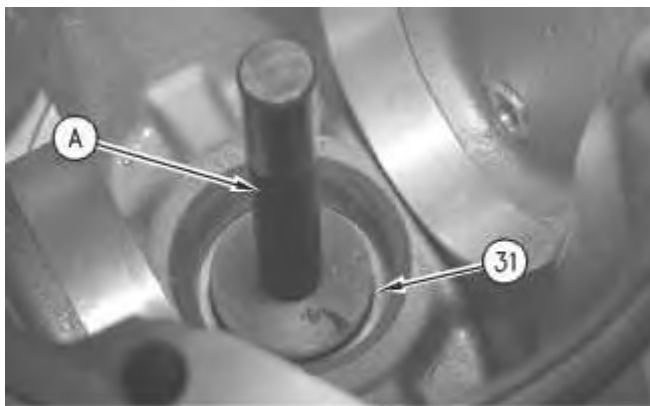

Illustration 2

g00521878

3. Use Tooling (A) to install lip seal (31) to the pump housing. The sealing lip of the lip seal should face toward the retaining ring. The lip seal must seat against the retaining ring.

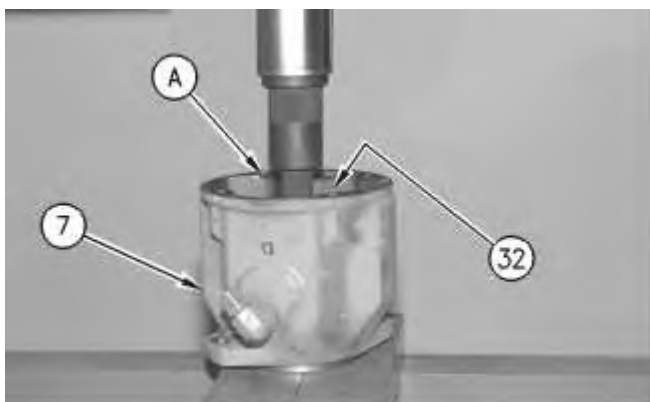

Illustration 3

g00521882

4. Lower the temperature of bearing cone (32). Use Tooling (A) to install bearing cone (32) to pump housing (7). Install bearing cone (32) until the bearing cone seats.



Illustration 4

g00521857

5. Install brass bearings (29) to pump housing (7).

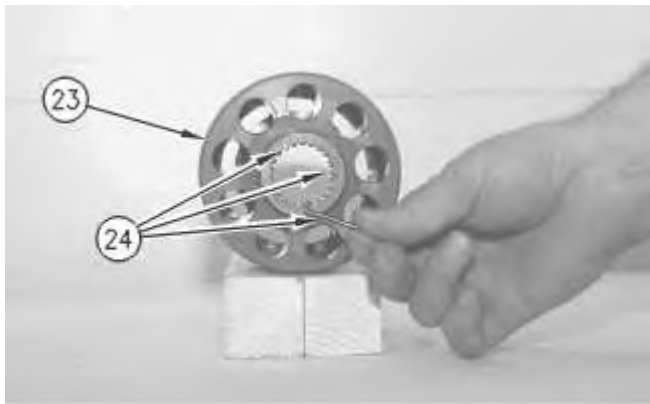

Illustration 5

g00521880

6. Install pins (24) to body (23).

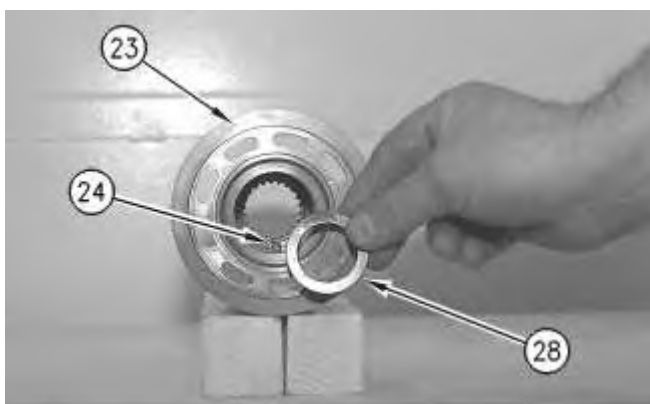

Illustration 6

g00521854

7. Install seat (28) to secure pins (24) in body (23).

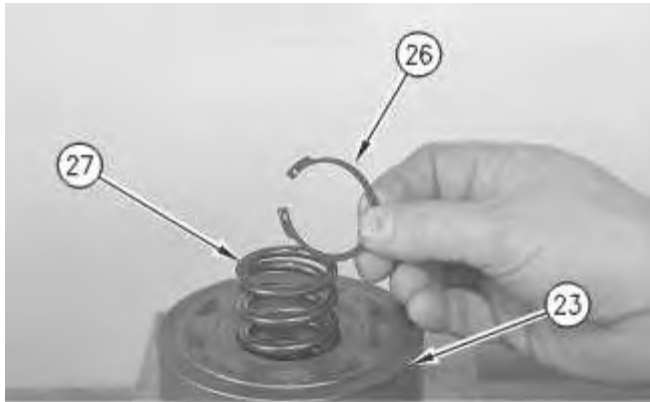

Illustration 7

g00521853

8. Position body (23) in a hydraulic press. Install spring (27) in body (23). Position retaining ring (26) on top of the spring.

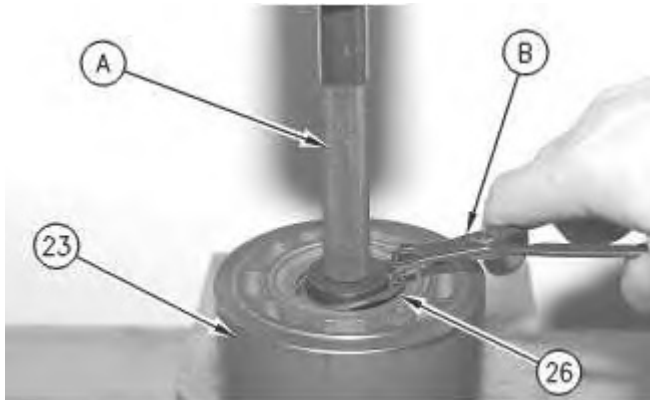

Illustration 8

g00521852

9. Position Tooling (A) and the hydraulic press on top of the spring and inside of retaining ring (26). Use Tooling (A) to depress the spring that is in body (23). Use Tooling (B) to install retaining ring (26) that secures the spring in body (23). Remove Tooling (A).

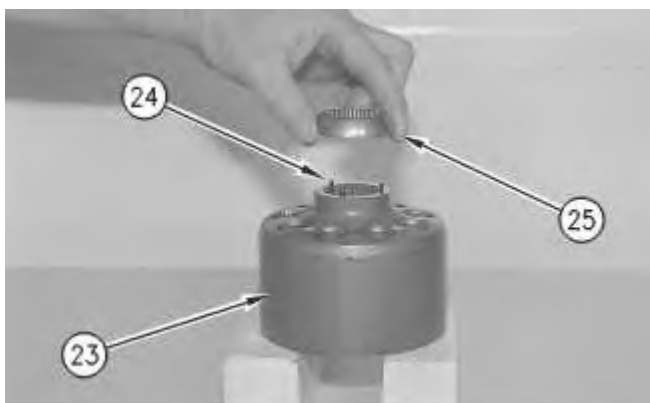

Illustration 9

g00521851

10. Install collar bearing (25) to pins (24) and body (23).

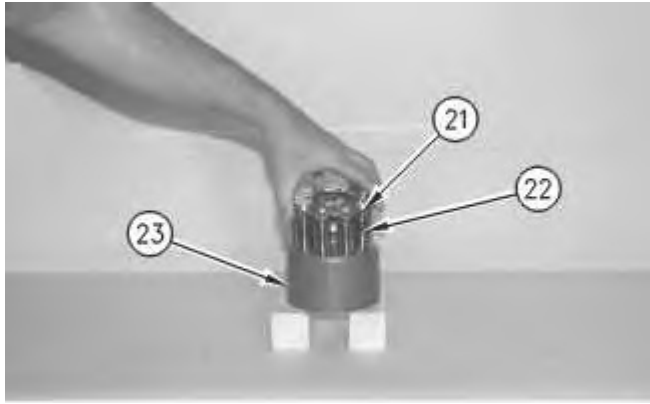

Illustration 10

g00521850

11. Install pistons (22) to the original positions in retraction plate (21). Install pistons (22) and retraction plate (21) to body (23). Pistons (22) must be installed to the original positions.

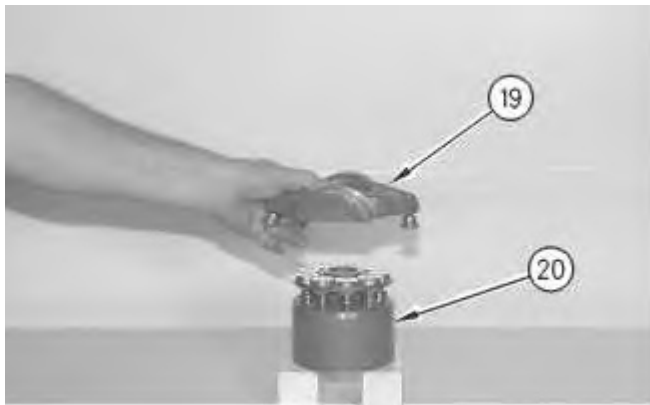

Illustration 11

g00521849

12. Position swashplate (19) to rotating group (20).

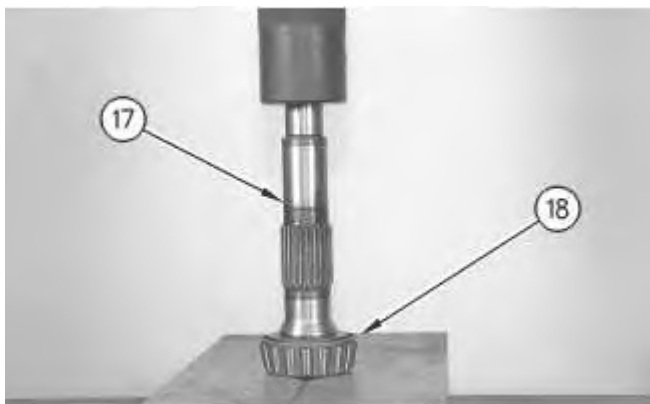

Illustration 12

g00521881

13. Lower the temperature of shaft (17). Use a hydraulic press to install shaft (17) in roller bearing (18). Install the shaft until the bearing is seated to the shaft.

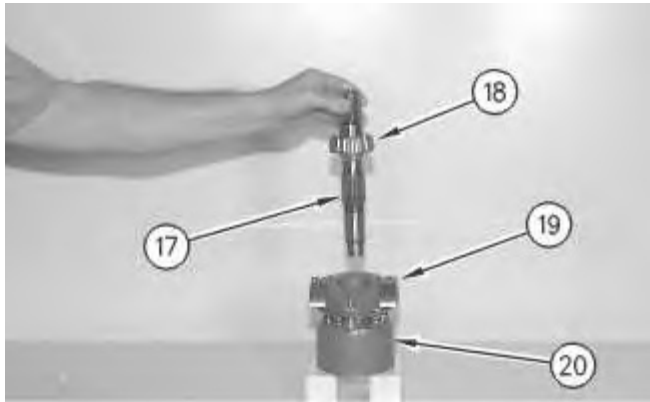

Illustration 13

g00521848

14. Install shaft (17) and bearing (18) to swashplate (19) and rotating group (20).
15. Apply clean hydraulic oil to the components of the pump.

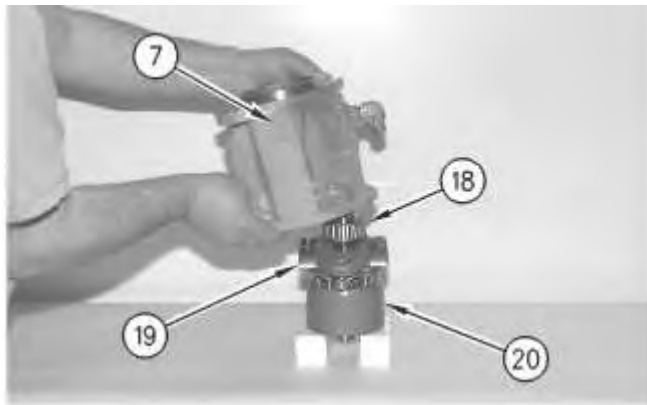

Illustration 14

g00521847

16. Install pump housing (7) to bearing (18), shaft (17), swashplate (19), and rotating group (20). Turn the pump body over 180 degrees and hold the components in the pump body.

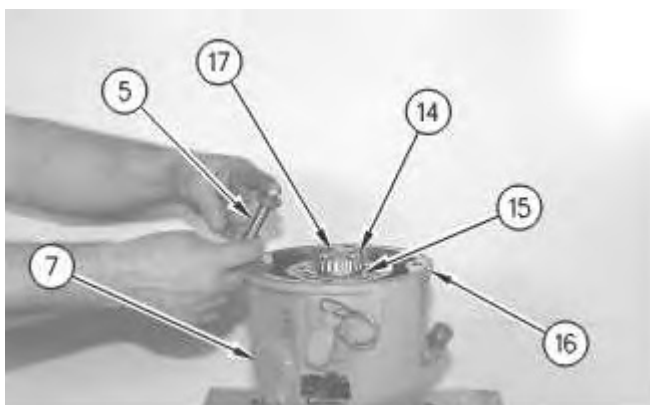

Illustration 15

g00521884

17. Position pump housing (7) on appropriate cribbing. Position shaft (17) between the two blocks of wood.
18. Install roller bearing (14) and spacer (15) to shaft (17). Apply clean hydraulic oil to the roller bearing. Install O-ring seal (16) to pump housing (7).
19. Apply Tooling (D) to plunger (5).

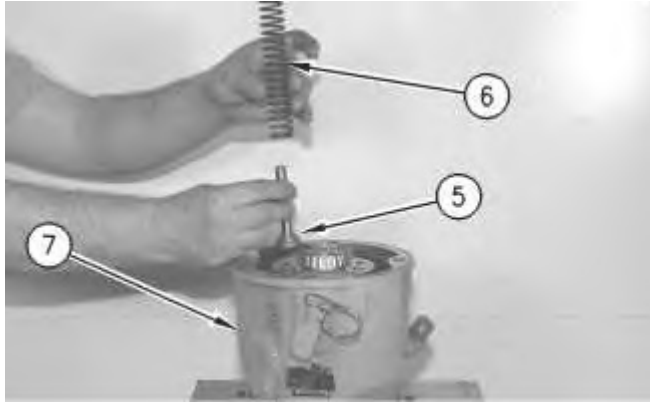

Illustration 16

g00521885

20. Position plunger (5) to the wear pad that is positioned on the swashplate. The silicone will hold the plunger in place. Install spring (6) on plunger (5).

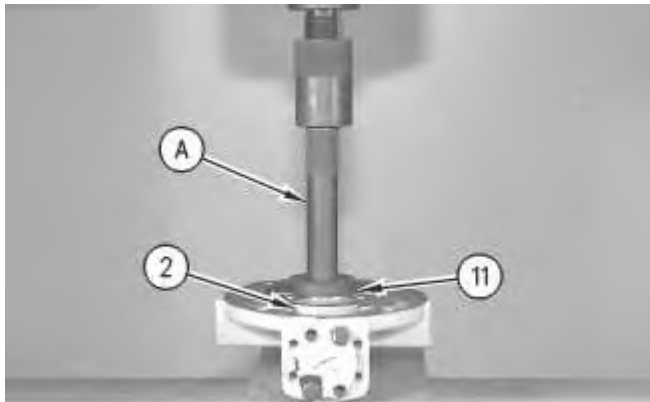

Illustration 17

g00521879

21. Lower the temperature of bearing cup (11). Use Tooling (A) and a hydraulic press to install bearing cone (11) in pump head (2). Install the bearing cone until the cone is seated.
-

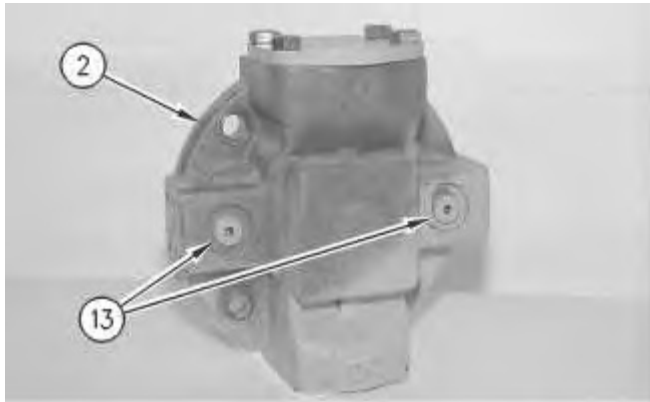

Illustration 18

g00521845

22. Install the O-ring seals to plugs (13). Install plugs (13) to pump head (2). Tighten the plugs to a torque of  $45 \pm 5 \text{ N}\cdot\text{m}$  ( $33 \pm 4 \text{ lb ft}$ ).

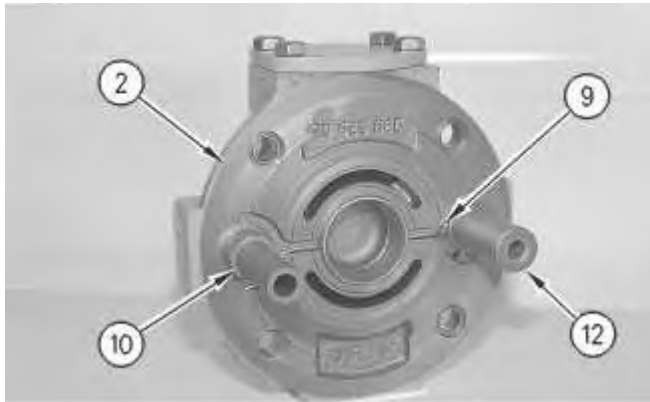

Illustration 19

g00521886

23. Install locating pin (9) to pump head (2). Check cylinder (10) and guide (12) for nicks or wear. Apply Tooling (D) to guide (12).

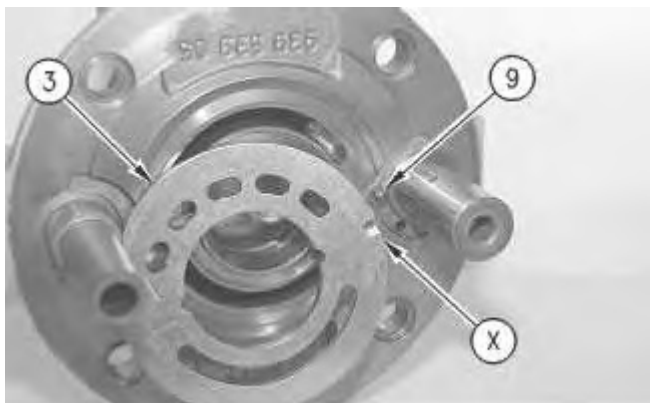

Illustration 20

g00521843

24. Apply Tooling (D) to the side of plate (3) that has slot (X). Slot (X) will be positioned over locating pin (9) when plate (3) is installed to the pump head.

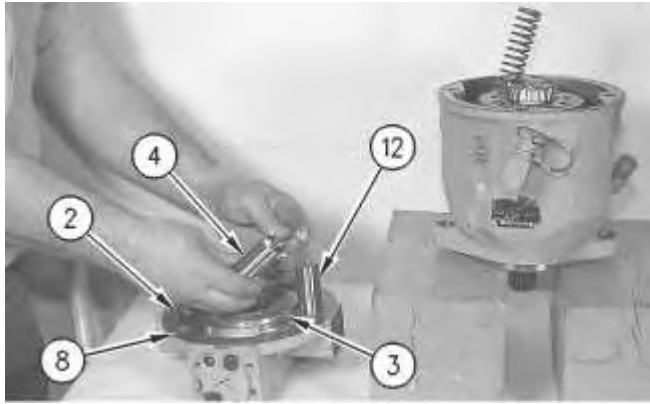

Illustration 21

g00521887

25. Install plate (3) to pump head (2). Install four O-ring seals (8) to pump head (2). Apply Tooling (D) to piston (4). Install piston (4) to guide (12).

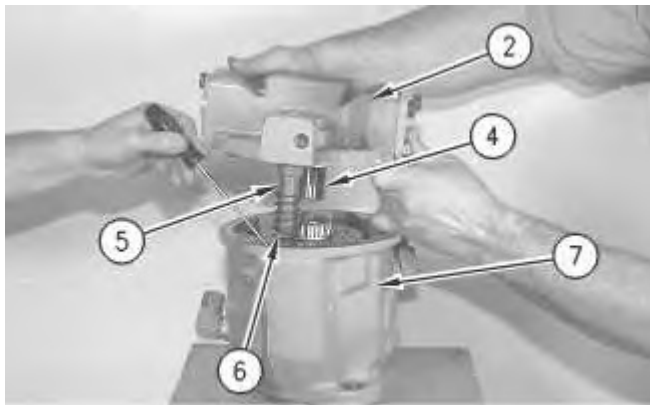
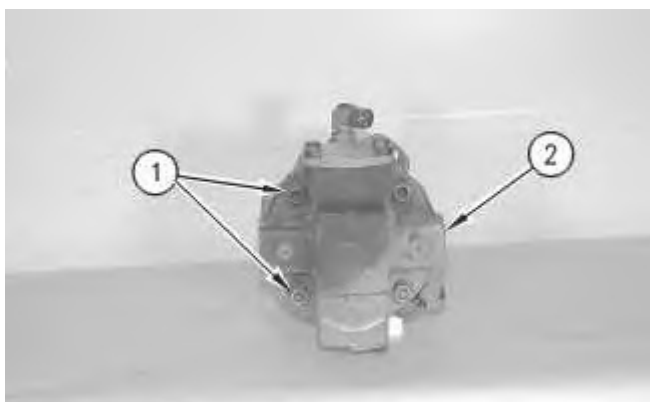

Illustration 22

g00521888

26. Install pump head (2), plate (3), piston (4), plunger (5), and spring (6) as a unit to pump housing (7). Remember to align the marks that were applied to the mating components.
27. Use two persons to maneuver plunger (5) into spring (6). Position piston (4) to the wear pad that is positioned on the swashplate. The silicone will hold the piston in place.
28. When all the components are aligned, pump head (2) should be positioned to pump housing (7).



29. Install four bolts (1) that secure pump head (2) to the pump assembly. The head is under spring tension. Install the bolts slowly. Tighten bolts (1) to a torque of  $165 \pm 30 \text{ N}\cdot\text{m}$  ( $122 \pm 22 \text{ lb ft}$ ).
30. Fill the pump with hydraulic oil before installing the pump to the machine.

**End By:**

- a. Install the piston pump (steering). Refer to Disassembly and Assembly, "Piston Pump (Steering) - Install"  
. The information is in this manual.



**Suggest:**

**If the above button click is invalid.**

**Please download this document**

**first, and then click the above link**

**to download the complete manual.**

**Thank you so much for reading**

[Previous Screen](#)

Product: ARTICULATED TRUCK

Model: D250E II ARTICULATED TRUCK 4PS

Configuration: D250E Series II Articulated Truck 4PS00001-UP (MACHINE) POWERED BY 3306 Engine

## Disassembly and Assembly

### D250E Series II and D300E Series II Articulated Trucks Machine Systems

Media Number -SEN9129-01

Publication Date -01/09/2004

Date Updated -21/09/2004

i01017329

## Piston Pump (Steering) - Install

SMCS - 5070-012-ZH

### Installation Procedure

1. Inspect all parts and clean all parts. If any parts are worn or damaged, use new Caterpillar parts for replacement.

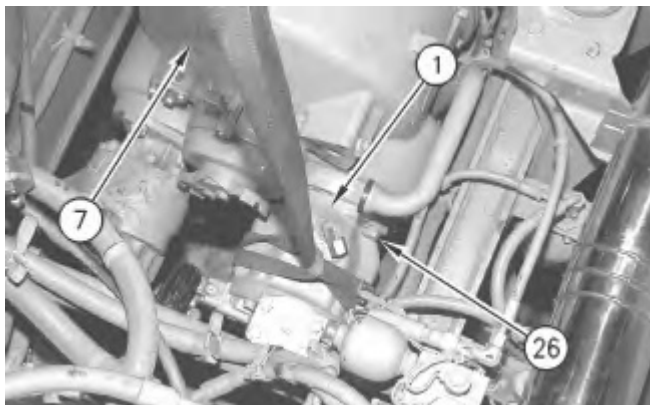

Illustration 1

g00521792

2. Install the O-ring seal to hydraulic steering pump (1). Attach a nylon lifting strap and a hoist to hydraulic steering pump (1). Use the hoist and move hydraulic steering pump (1) in torque converter (7). The weight of hydraulic steering pump (1) is 34 kg (75 lb).
3. Install two bolts (26) and the washers that secure hydraulic steering pump (1) to torque converter (7) .

**<https://www.ebooklibonline.com>**

Hello dear friend!

Thank you very much for reading.

Enter the link into your browser.

The full manual is available for immediate download.

**<https://www.ebooklibonline.com>**