



# Service Repair Manual

## **Models**

# 966F WHEEL LOADER

---

[Previous Screen](#)

Product: WHEEL LOADER

Model: 966F WHEEL LOADER 4YG

Configuration: 966F WHEEL LOADER 4YG00001-UP (MACHINE) POWERED BY 3306 ENGINE

## Disassembly and Assembly 966F WHEEL LOADER POWER TRAIN

Media Number -SEN4771-04

Publication Date -01/12/2005

Date Updated -18/02/2005

SEN47710017

### Differential (Limited Slip)

SMCS - 3263-016; 3263-015

### Disassemble Differential (Limited Slip)

Start By:

- a. remove differentials and pinion assemblies

**NOTE:** DO NOT use this procedure with limited slip differential Part Nos. **102-7507** and **142-0444**. Refer to "Disassemble & Assemble Differential (Limited Slip) (Part Nos. **102-7507** & **142-0444**)" in this module.

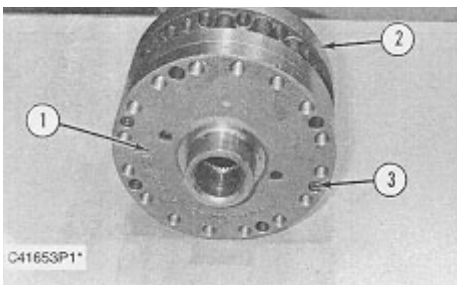

1. Remove two socket head bolts (3). Turn the differential up on differential housing cover (1), and remove differential housing (2).

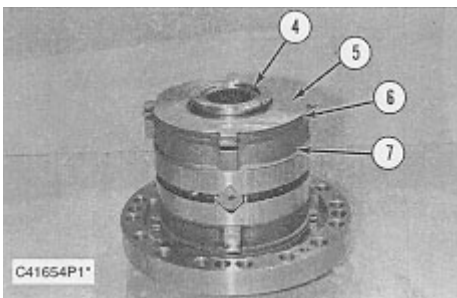

2. Remove thrust washer (4), two outer discs (5), two inner discs (6) and pressure ring (7).

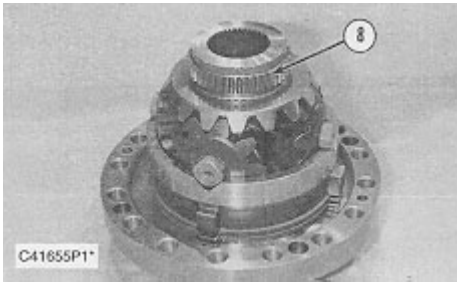

3. Remove bevel gear (8).

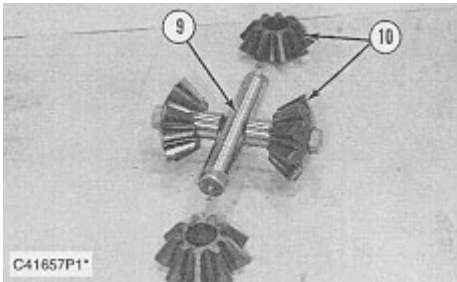
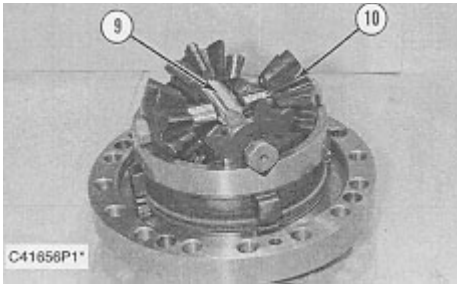

4. Remove four bevel pinions (10) and two pinion shafts (9).

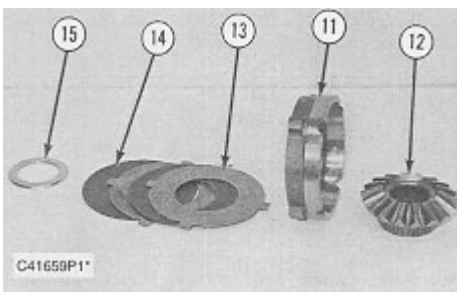
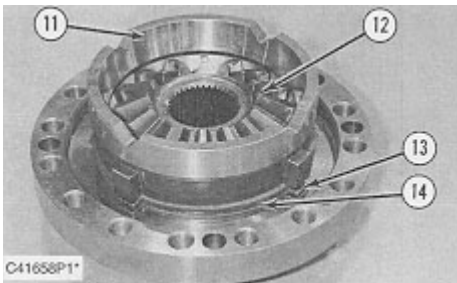

5. Remove bevel gear (12), pressure ring (11), two outer discs (13), two inner discs (14) and thrust washer (15).

**<https://www.ebooklibonline.com>**

Hello dear friend!

Thank you very much for reading.

Enter the link into your browser.

The full manual is available for immediate download.

**<https://www.ebooklibonline.com>**

## Assemble Differential (Limited Slip)

**NOTE:** DO NOT use this procedure with limited slip differential Part Nos. **102-7507** and **142-0444**. Refer to "Disassemble & Assemble Differential (Limited Slip) (Part Nos. **102-7507** & **142-0444**)" in this module.

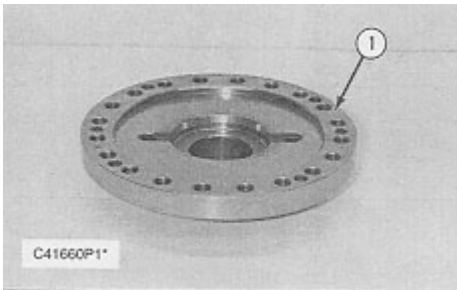

1. Put differential housing cover (1) in the position shown.

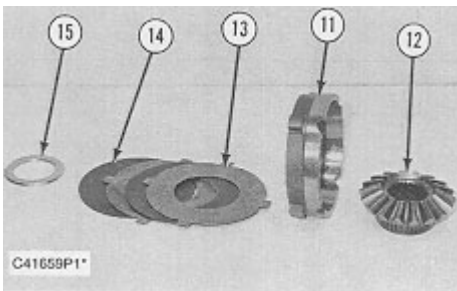
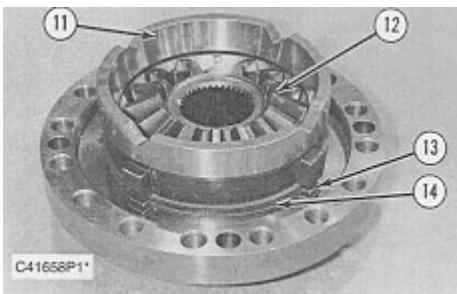

2. Install thrust washer (15), two inner discs (14), two outer discs (13), ring (11) and bevel gear (12) on differential housing cover (1).

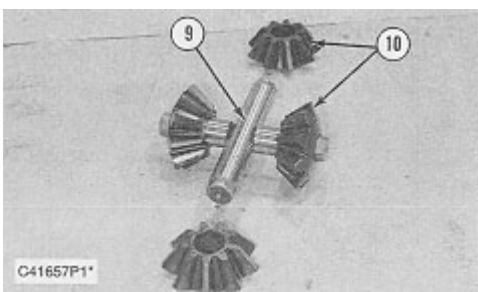

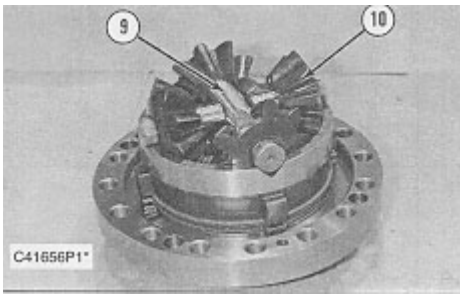

**3.** Install bevel gears (10) on pinion shafts (9). Install the bevel gears and pinion shafts on the pressure ring.

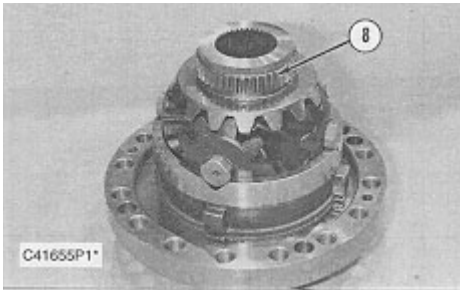

**4.** Install bevel gear (8).

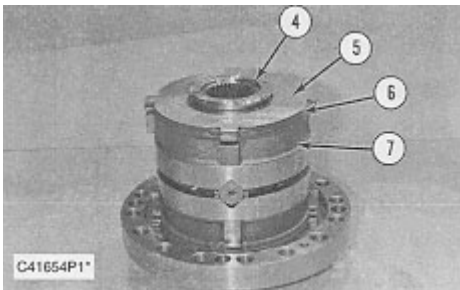

**5.** Install pressure ring (7), two inner discs (6), two outer discs (5) and thrust washer (4).

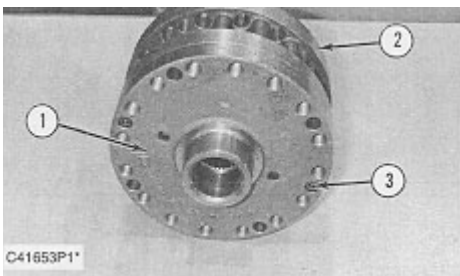

**6.** Install differential housing (2). Install two socket bolts (3). Tighten socket head bolts (3) to a torque of  $54 \pm 10$  N·m ( $40 \pm 7$  lb ft).

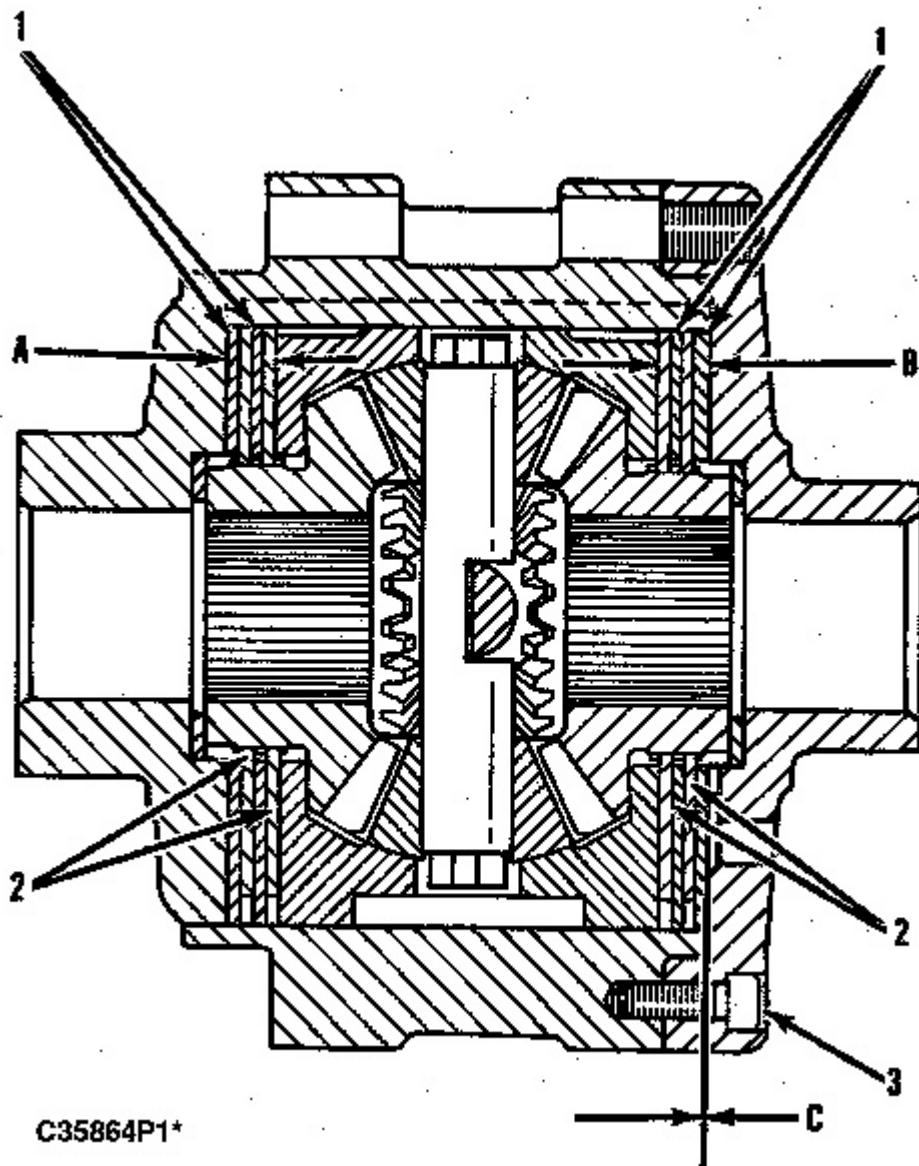

7. Check the end play. Replace the inner and outer discs, as necessary, to maintain an endplay of  $0.5 \pm 0.3$  mm (.020  $\pm$  .012 in) after assembly.

**NOTE:** The thickness of the **8R-8733** disc [outer (new)] is 3.90 mm (.154 in). The thickness of the **8R-8734** disc [outer (new)] is 4.0 mm (.157 in). The thickness of the **8R-8735** disc [outer (new)] is 4.1 mm (.161 in). The thickness of the **8R-8736** disc [inner (new)] is 4.1 mm (.161 in).

**NOTE:** Average the stack heights of (A) & (B). The difference must be within 0.10 mm (.004 in).

End By:

a. install differentials and pinion assemblies

**Disassemble Differential (Limited Slip) (Part Nos. 102-7507 & 142-0444)**

Tools Needed		A	B
1U-9895	Cross Block	1	
1U-5477	Ring	1	
1P-0526	Plate (Part of 1P-0520 Driver Gp.)	1	
7X-2556	Bolt (M16 X 2.0 X 100)	1	
9X-8257	Washer (M16)	1	
8T-4132	Nut (M16 X 2.0)	1	
7X-2546	Bolt (M12 X 1.75 X 180)	2	
8T-4121	Washer (M10)	2	
8T-4223	Washer (M12)	2	
9X-8257	Washer (M16)	2	
8T-5096	Dial Indicator Group		1

Start By:

a. remove differential

**NOTE:** Use this procedure with limited slip differential Part Nos. **102-7507** and **142-0444**. All others refer to "Disassemble & Assemble Differential (Limited Slip)" in this module.

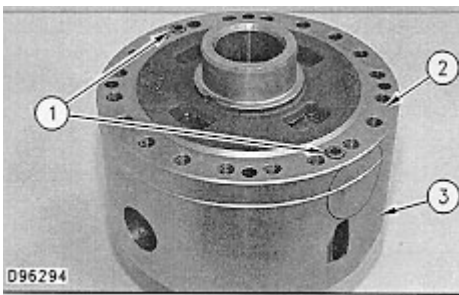

1. Remove two bolts (1).
2. Remove case cover (2) from case housing (3).

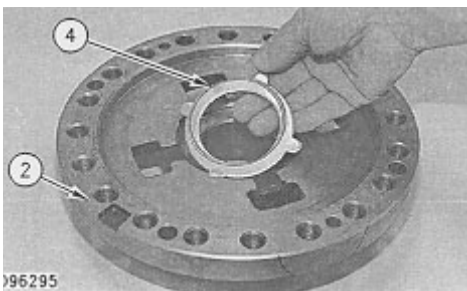

3. Invert case cover (2) and remove thrust washer (4).
4. Measure the end play gap, as follows:

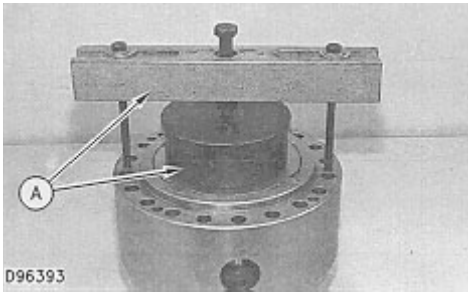

a. Install Tooling (A) on the differential assembly, as shown.

**NOTE:** The center pusher bolt of Tooling (A) must have M16 x 2.0 thread to apply the proper preload on the disc packs.

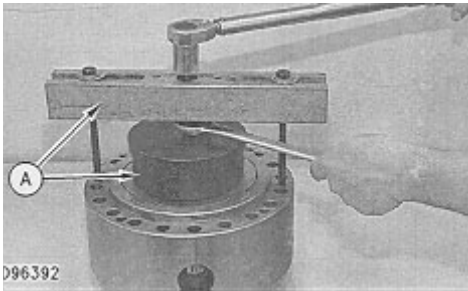

b. Tighten the center bolt of Tooling (A) to a torque of 27 N·m (20 lb ft) to apply 900 kg (2000 lb) of preload on the disc packs.

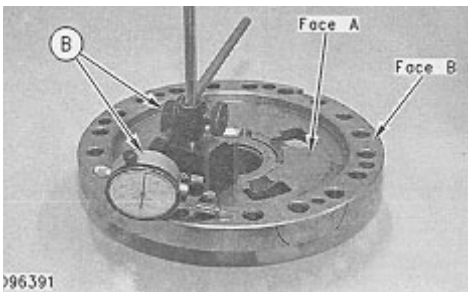

c. Mount the magnetic base of Tooling (B) on Face A of case cover (2).

d. Zero the dial indicator on Face B, as shown.

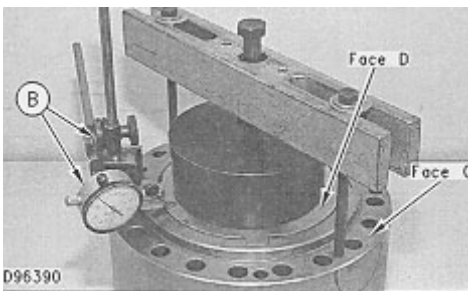

e. Carefully remove Tooling (B) from the case cover.

f. Mount the magnetic base of Tooling (B) on Face C of the differential case housing. Touch the dial indicator on the disc pack Face D.

g. Record the indicator reading.

- h.** Record two additional indicator readings from different areas of Face D.
- i.** Average the three indicator readings. This is the measured end play gap.
- j.** If the end play gap in Step 4i was greater than 0.81 mm (.032 in), replacement of the existing disc packs is necessary.

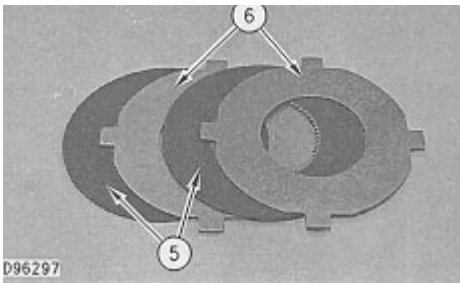
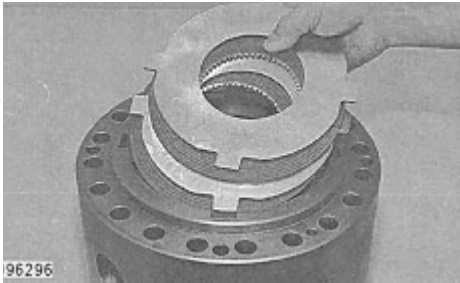

- 5.** Remove the disc pack from the case housing. The disc pack consists of two friction discs (5) and two plates (6).

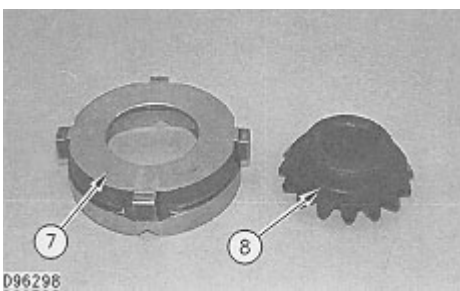
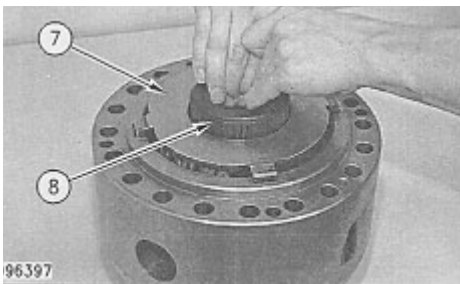

- 6.** Remove actuator housing (7) and gear (8) from the case housing, as shown.

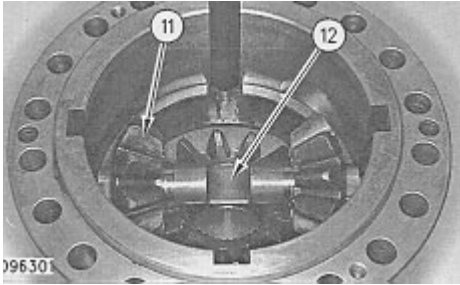
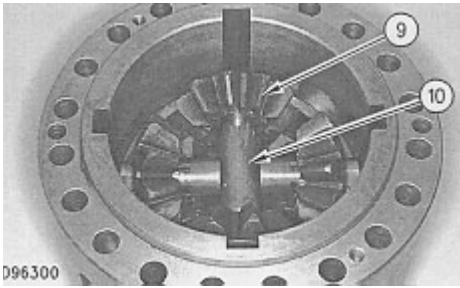

7. Remove pinion shaft (10) and two pinion gears (9).

8. Remove the remaining pinion shaft (12) and two pinion gears (11).

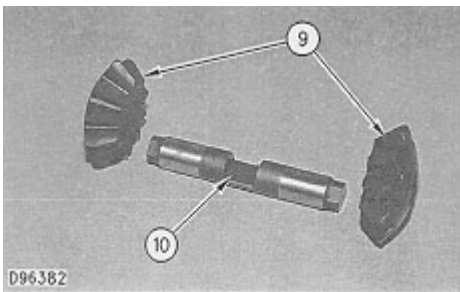

9. Remove two pinion gears (9) from pinion shaft (10). Repeat for the remaining pinion shaft (12) and pinion gears (11).

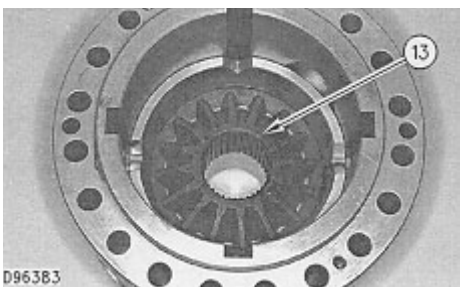

10. Remove gear (13) from the case housing.

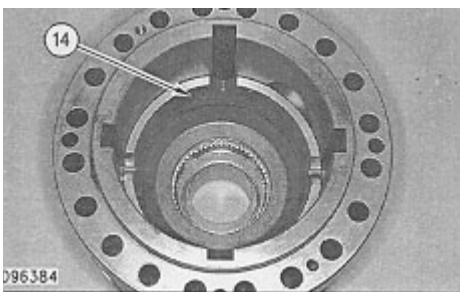

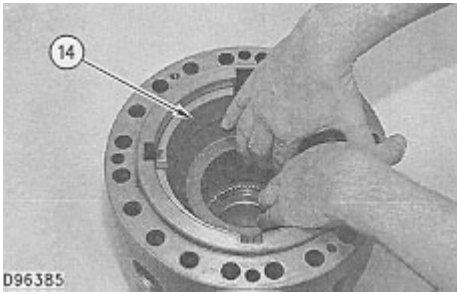

11. Remove actuator housing (14) from the case housing by lifting straight upward, as shown.

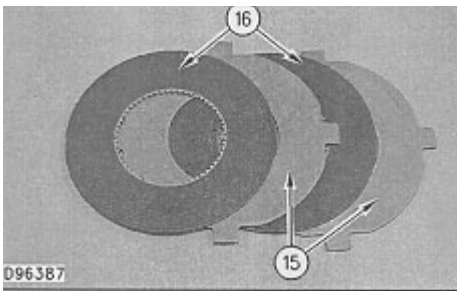
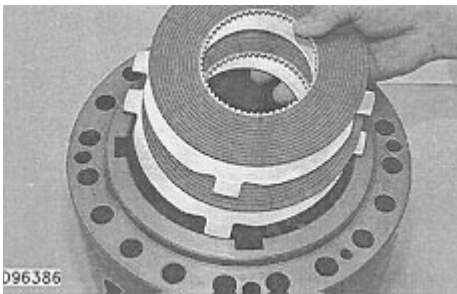

12. Remove the disc pack from the case housing. The disc pack consists of two friction discs (16) and two plates (15).

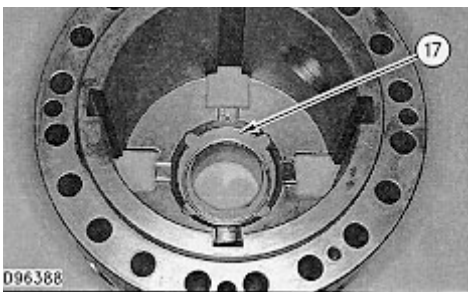

13. Remove thrust washer (17).

**Assemble Differential (Limited Slip) (Part Nos. 102-7507 & 142-0444)**

Tools Needed		A	B
1U-9895	Cross Block	1	
1U-5477	Ring	1	
1P-0526	Plate (Part of 1P-0520 Driver Gp.)	1	
7X-2556	Bolt (M16 X 2.0 X 100)	1	
9X-8257	Washer (M16)	1	
8T-4132	Nut (M16 X 2.0)	1	
7X-2546	Bolt (M12 X 1.75 X 180)	2	
8T-4121	Washer (M10)	2	
8T-4223	Washer (M12)	2	
9X-8257	Washer (M16)	2	
8T-5096	Dial Indicator Group		1

**NOTE:** Use this procedure with limited slip differential Part Nos. **102-7507** and **142-0444**. All others refer to "Disassemble & Assemble (Limited Slip)", in this module.

1. Clean and inspect all parts of the differential. If any of the parts are worn or damaged, use new parts for replacement.

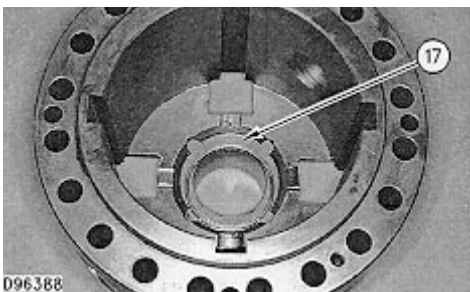

2. Install thrust washer (17) in the case housing. Lubricate the thrust washer face with clean axle oil.

3. Replace the disc packs if:

- a. The stack heights of the disc packs are NOT symmetrical within 0.10 mm (.004 in).
- b. The disc friction material is worn such that the discs, or areas of the discs, are running steel on steel.

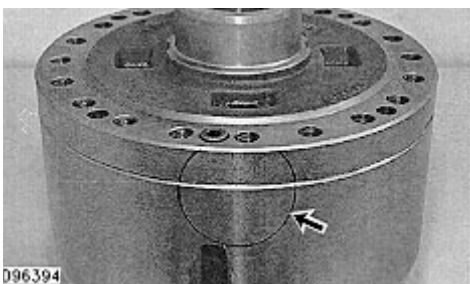

4. When replacement of the disc packs is required, replace with the disc packs of the same type. If THIN is marked on the case cover, replace with two new THIN disc packs. If THICK is marked on the case cover, replace with two new THICK disc packs. Do not mix disc packs. Use two THIN or two THICK. Do not use one of each.

**NOTE:** Use clean axle oil to thoroughly lubricate plates and friction discs, prior to assembly.

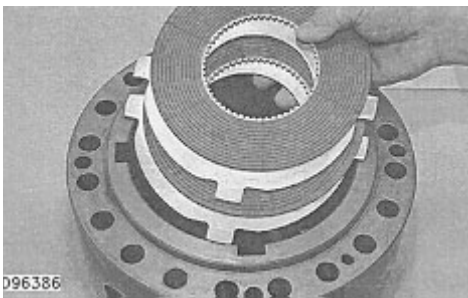
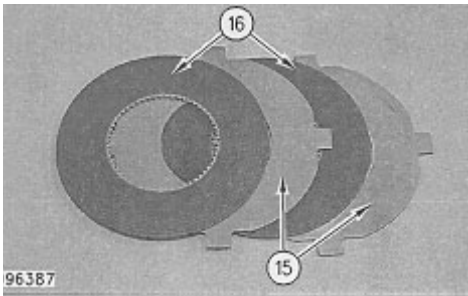

5. Install two friction discs (16) and two plates (15) in alternate order in the case housing starting with a plate and ending with a friction disc, as shown.

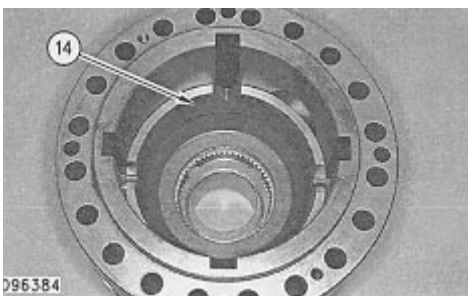
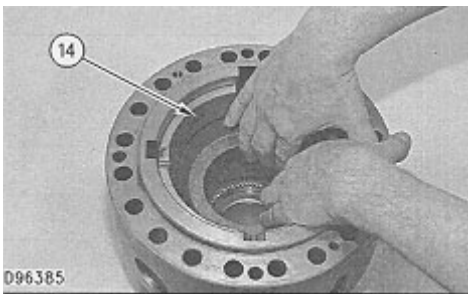

6. Align the keys of actuator housing (14) with the slots of the case housing and install, as shown.

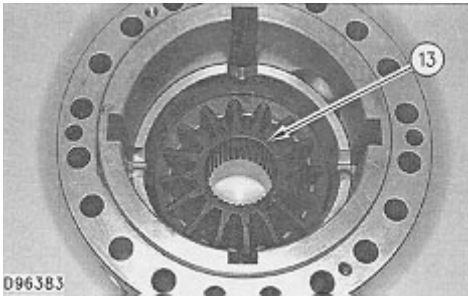

7. Install gear (13) in the case housing. Make sure the gear is fully seated.

**NOTE:** Turn the gear slowly until the spline engages with the two friction discs installed in Step 5.

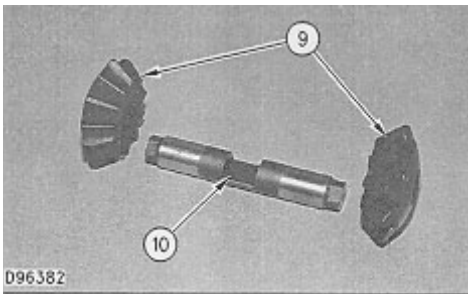

8. Install two pinion gears (9) on pinion shaft (10). Repeat for the remaining pinion shaft (12) and two pinion gears (11). Lubricate with clean axle oil.

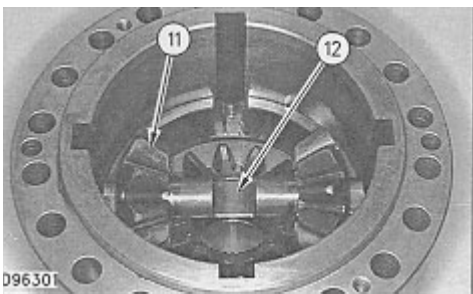

9. Install pinion shaft (12) and two pinion gears (11) in the case housing, as shown.

10. Rotate pinion gears (11) slightly until the pinion shaft rests in the V-slots of the actuator housing.

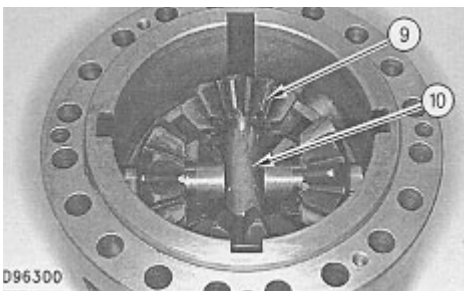

11. Install the remaining pinion shaft (10) and two pinion gears (9) in the case housing, as shown.

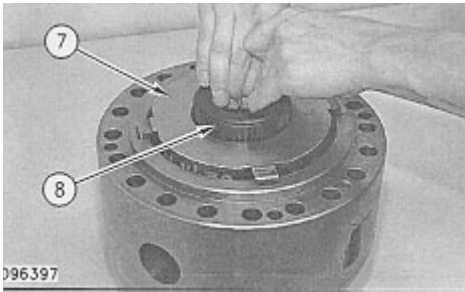
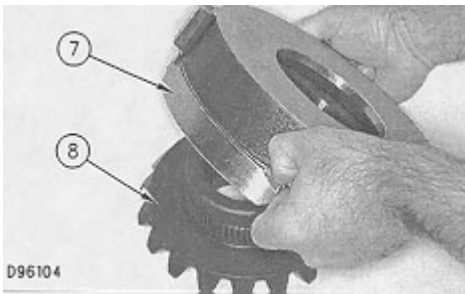

**12.** Assemble gear (8) and actuator housing (7) on bench, as shown. Align the keys of the actuator housing with the slots in the case housing and install, as shown.

**NOTE:** Use clean axle oil to thoroughly lubricate plates and friction discs, prior to assembly.

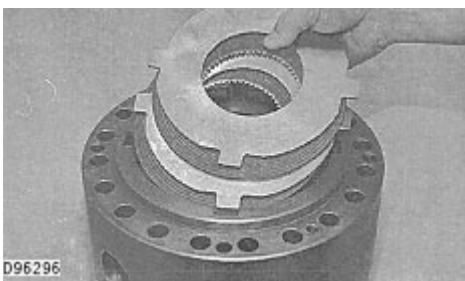
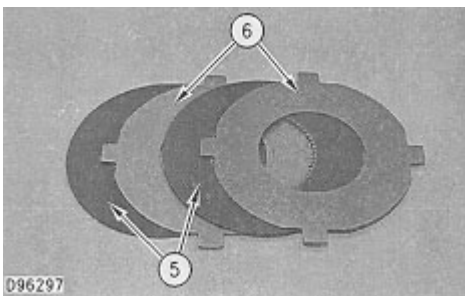

**13.** Install two friction discs (5) and two plates (6) in alternate order in the case housing starting with a friction disc and ending with a plate.

**NOTE:** Steps 14 through 22 describe the proper procedure for measuring end play gap.

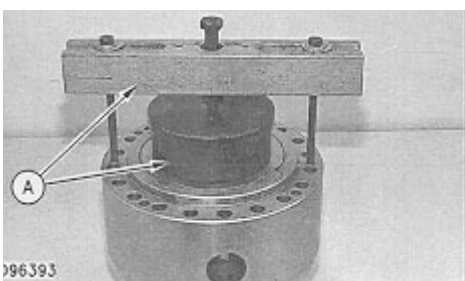

14. Install Tooling (A) on the differential assembly, as shown.

**NOTE:** The center pusher bolt of Tooling (A) must have M16 x 2.0 thread to apply the proper preload on the disc packs.

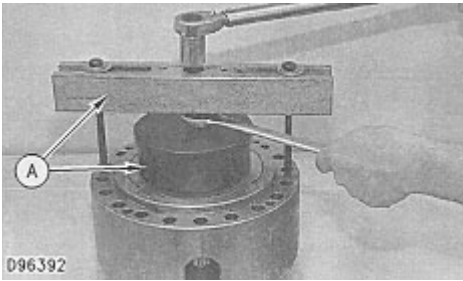

15. Tighten the center bolt of Tooling (A) to a torque of 27 N·m (20 lb ft) to apply 900 kg (2000 lb) of preload on the disc packs.

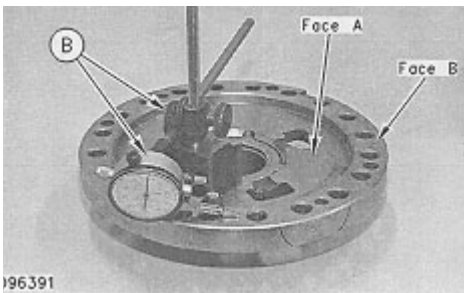

16. Mount the magnetic base of Tooling (B) on Face A of case cover (2).

17. Zero the dial indicator on Face B, as shown.

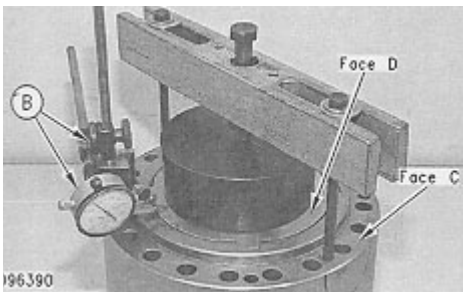

18. Carefully remove Tooling (B) from the case cover.

19. Mount the magnetic base of Tooling (B) on Face C on the differential case housing. Touch the dial indicator on the disc pack Face D.

20. Record the indicator reading.

21. Record two additional indicator readings from different areas of Face D.

22. Average the three indicator readings. This is the measured end play gap.

**NOTE:** If the existing disc packs were installed in Step 4, continue with Step 23. If new disc packs were installed in Step 4, continue with Step 24.

23. If the end play gap in Step 22 was greater than 0.81 mm (.032 in), replacement of the existing disc packs is necessary.

**NOTE:** Steps 24 through 28 are for new replacement disc packs.

**24.** When replacement of the disc packs is required, replace with disc packs of the same type. If THIN is marked on the case cover, replace with two new THIN disc packs. If THICK is marked on the case cover, replace with two new THICK disc packs. Do not mix disc packs. Use two THIN or two THICK. Do not use one of each.

**25.** With new disc packs installed in the limited slip differential, measure the end play gap as described in Steps 14 through 22. The measured end play gap must fall between 0.203 and 0.508 mm (.0080 and .0200 in).

**26.** If the measured end play gap is greater than 0.508 mm (.0200 in) and two THIN disc packs were installed, remove two THIN disc packs and install two THICK disc packs. Measure the end play gap again to determine if it falls between 0.203 and 0.508 mm (.0200 in) to meet specifications.

**27.** If the measured end play gap still does not meet specifications, replace the pinion shafts and or both actuator housings. Install either two THIN or two THICK disc packs to obtain an end play gap that falls between 0.203 and 0.508 mm (.0080 and .0200 in) to meet specifications.

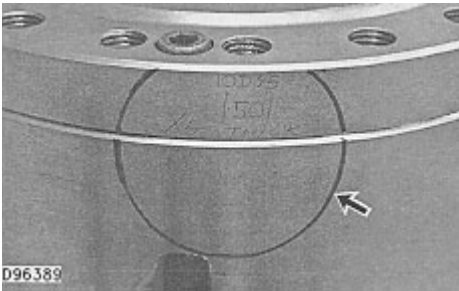

**28.** If the disc packs were changed from the kind marked on the outside surface of the case cover, replace the existing mark with either THICK or THIN for future reference.

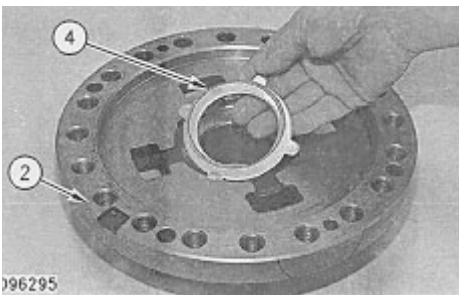

**29.** Install thrust washer (4) in case cover (2). Lubricate the thrust washer face with clean axle oil.

**NOTE:** Apply a small amount of grease to the back side of the thrust washer prior to installing. This will retain the thrust washer in place when the case cover is installed.

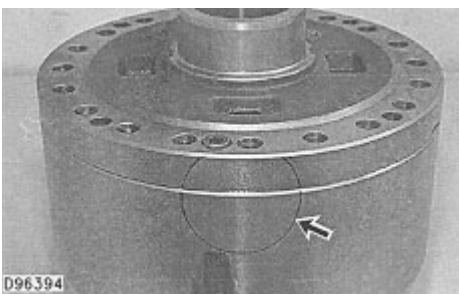

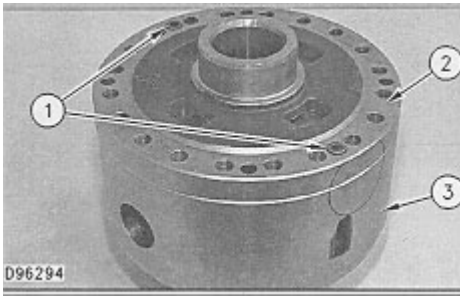

**30.** Align case housing and cover stamp marks. Install case cover (2) on case housing (3).

**31.** Install two bolts (1). Tighten bolts (1) to a torque of  $61 \pm 7$  N·m ( $45 \pm 5$  lb ft).

End By:

**a.** install differential

[Previous Screen](#)

Product: WHEEL LOADER

Model: 966F WHEEL LOADER 4YG

Configuration: 966F WHEEL LOADER 4YG00001-UP (MACHINE) POWERED BY 3306 ENGINE

## Disassembly and Assembly 966F WHEEL LOADER POWER TRAIN

Media Number -SEN4771-04

Publication Date -01/12/2005

Date Updated -18/02/2005

SEN47710018

### Differential (NoSPIN)

SMCS - 3265-015; 3265-016

### Disassemble Differential (NoSPIN)

Start By:

- a. remove differentials and pinion assemblies

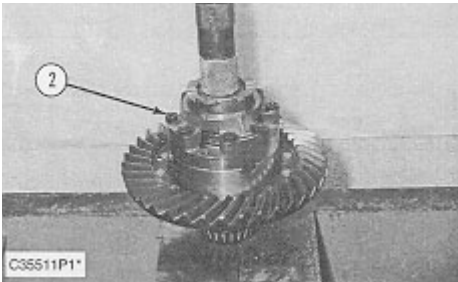

Typical Example

1. Put alignment marks on the differential case halves.



**There is spring force against the differential case half. When bolts (2) are removed, the spring force will be released. To prevent possible personal injury, removal of the case half should be performed in a press in order to retain the case half.**

2. Put the differential in a press, and remove bolts (2). Slowly release the spring compression.

3. Remove the differential case half.

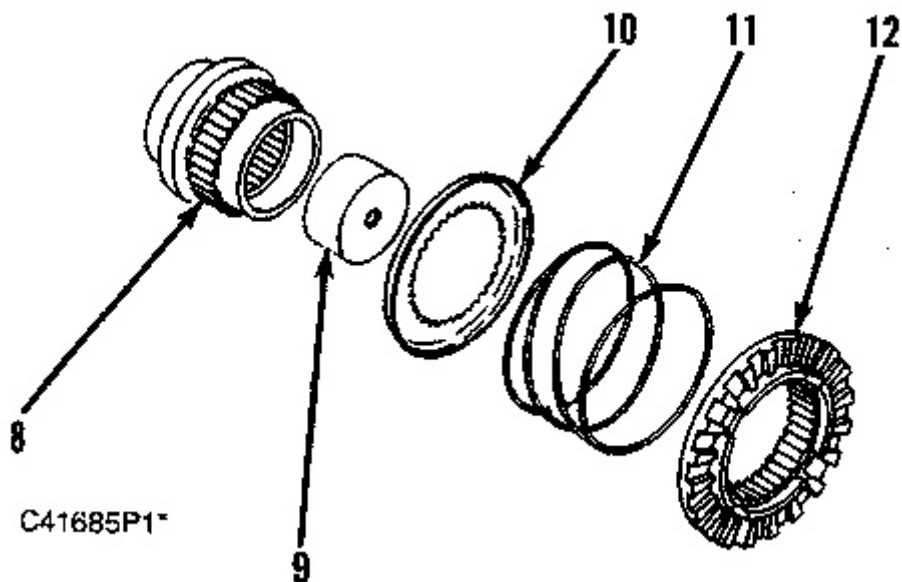

4. Remove side gear (8), spacer block (9), retainer (10), spring (11) and holdout ring and clutch assembly (12).

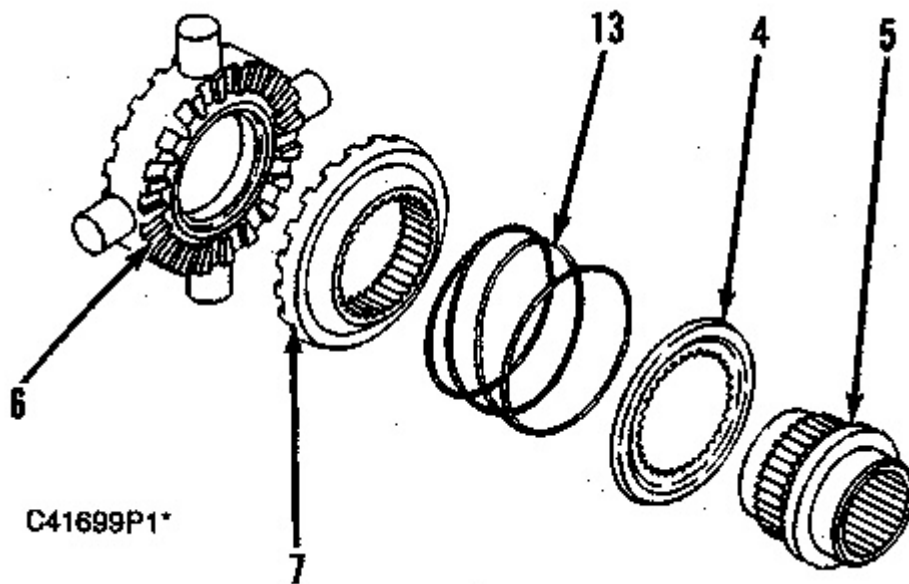

5. Remove spider cam assembly (6), holdout ring and clutch assembly (7), spring (13), retainer (4), and side gear (5).

### Assemble Differential (NoSPIN)

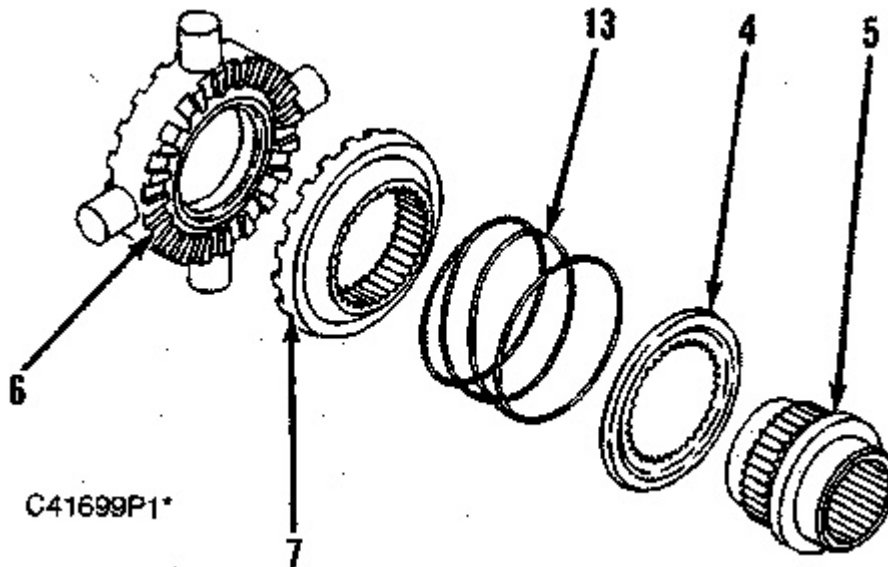

 **WARNING**

**Personal injury can result from being struck by parts propelled by a released spring force.**

**Make sure to wear all necessary protective equipment.**

**Follow the recommended procedure and use all recommended tooling to release the spring force.**

- 
1. Put one of the case halves in a press.
  2. Install side gear (5), retainer (4), spring (13), holdout ring and clutch assembly (7) and spider cam assembly (6).

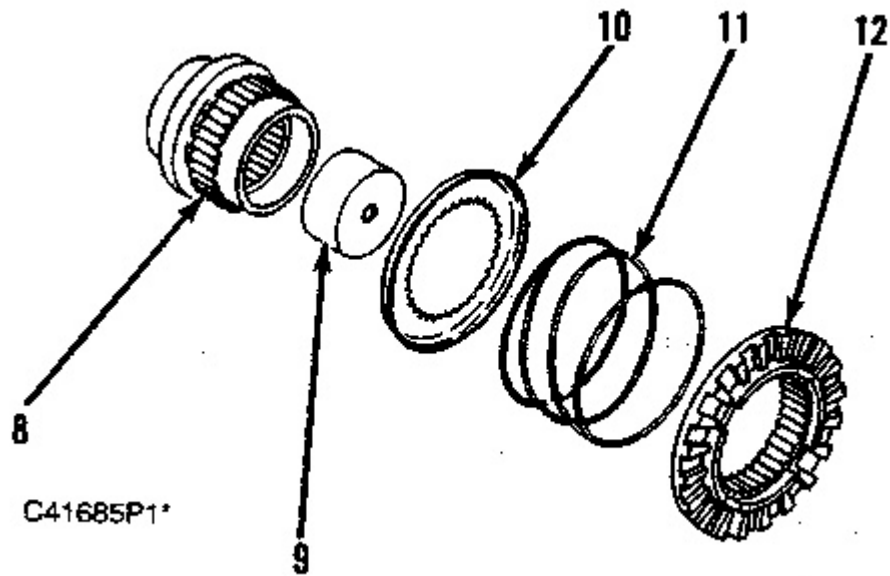

3. Install holdout ring and clutch assembly (12), spring (11), retainer (10), spacer block (9) and side gear (8).

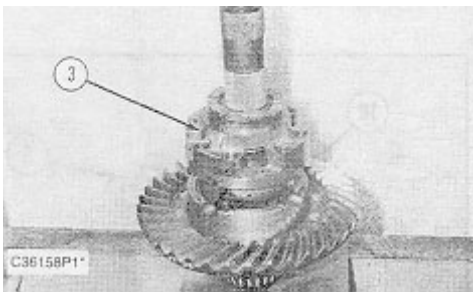

Typical Example

4. Install case half (3). Use press to compress the springs in the differential.

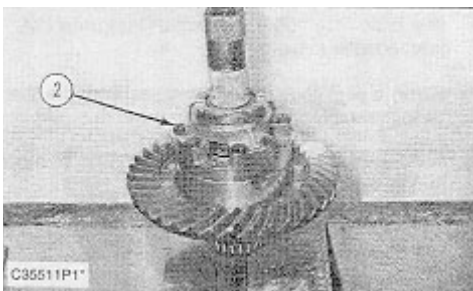

Typical Example

---

## NOTICE

**A new differential group or a new case assembly will be equipped with four bolts and washers that are used for shipping, assembly and storage purposes only. Remove and discard these four bolts and**

**washers after the bevel gear has been installed. These four bolts and washers should not be used for final assembly.**

---

**5.** Install bolts (2) that hold the differential case halves together.

End By:

**a.** install differential and pinion assemblies

---

[Copyright 1993 - 2020 Caterpillar Inc.](#)

Sat Mar 21 16:09:38 UTC+0800 2020

[All Rights Reserved.](#)

[Private Network For SIS Licensees.](#)

Previous Screen

Product: WHEEL LOADER

Model: 966F WHEEL LOADER 4YG

Configuration: 966F WHEEL LOADER 4YG00001-UP (MACHINE) POWERED BY 3306 ENGINE

**Disassembly and Assembly  
966F WHEEL LOADER POWER TRAIN**

Media Number -SEN4771-04

Publication Date -01/12/2005

Date Updated -18/02/2005

SEN47710019

## Transmission Oil Filter

SMCS - 3179-010; 3179-017

### Remove & Install Transmission Oil Filter

Tools Needed		A
2P-8250	Strap Wrench Assembly	1

**NOTE:** If only the transmission oil filter element is to be serviced, see the Operation & Maintenance Manual.

---

#### NOTICE

**Do not remove or install the transmission oil filter housing with an air wrench. See the Operation & Maintenance Manual for the correct service intervals for the transmission oil filter.**

---

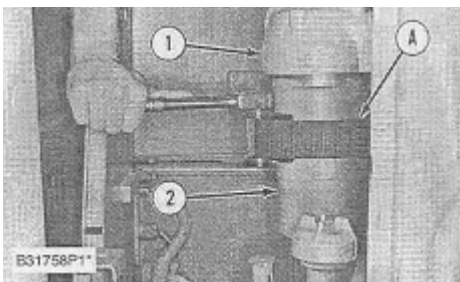

Typical Example

**1.** Using Tooling (A), remove filter housing (2) from filter base (1). Remove the filter element from the filter housing.

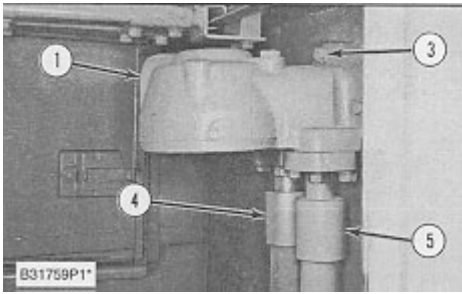

2. Disconnect hose assemblies (4) and (5) from filter base (1).
3. Remove three bolts (3) and the washers. Remove filter base (1) from its mounting base.

**NOTE:** The following steps are for the installation of the transmission oil filter.

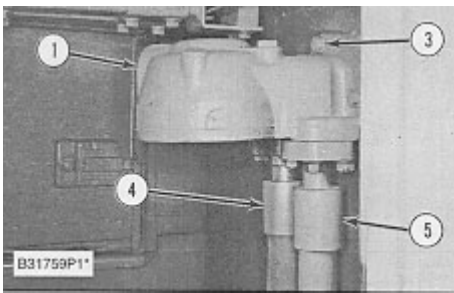

4. Check the condition of the O-ring seal in filter base (1). If the seal is worn or damaged, use a new part for replacement. Put filter base (1) in position on its mounting base, and install three bolts (3) and the washers which hold it.
5. Check the condition of the O-ring seals in the ends of hoses (4) and (5). If the seals are worn or damaged, use new parts for replacement.
6. Connect hose assemblies (4) and (5) to filter base (1).
7. Install a new filter element in the filter housing on the filter base. Be sure the filter housing is seated against the filter base.
8. Check the fluid level of the transmission. See the Operation & Maintenance Manual for the correct filling procedure.

## Disassemble & Assemble Transmission Oil Filter

Start By:

- a. remove transmission oil filter

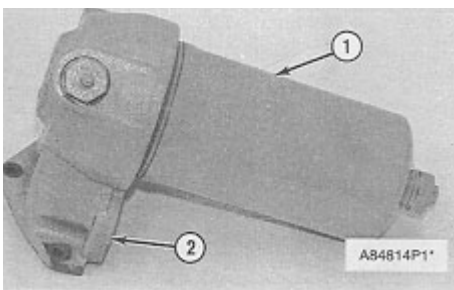



**Suggest:**

**If the above button click is invalid.**

**Please download this document**

**first, and then click the above link**

**to download the complete manual.**

**Thank you so much for reading**

1. Remove filter housing (1) from filter base (2).

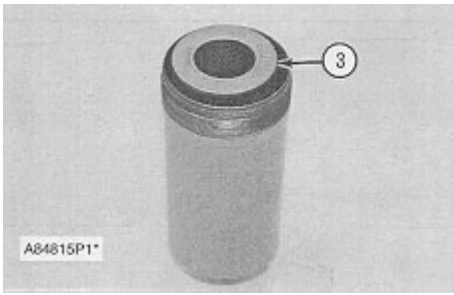

2. Remove filter element (3) from the filter housing. Remove the O-ring seal from the filter base.

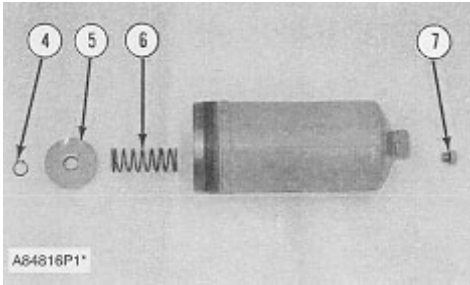

3. Remove plug (7) from the bottom of the filter housing. Remove the O-ring seal from plug (7).



**There is spring force against retaining ring (4) and retainer (5). When retaining ring (4) is removed, the spring force will be released. To prevent possible personal injury, retainer (5) must be held in position when retaining ring (4) is removed.**

4. While holding retainer (5) in position, remove retaining ring (4). Remove retainer (5) and spring (6) from the filter housing.

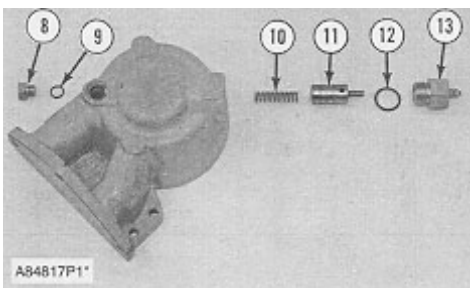

5. Remove plug (8) from the filter base. Remove O-ring seal (9) from plug.

6. Remove switch (13), spool (11) and spring (10) from the filter base. Remove O-ring seal (12) from the switch.

**NOTE:** The following steps are for the assembly of the transmission oil filter.

**<https://www.ebooklibonline.com>**

Hello dear friend!

Thank you very much for reading.

Enter the link into your browser.

The full manual is available for immediate download.

**<https://www.ebooklibonline.com>**