



Service Repair Manual

Models

903C COMPACT WHEEL LOADER

[Previous Screen](#)

Product: COMPACT WHEEL LOADER

Model: 903C COMPACT WHEEL LOADER W6T

Configuration: 903C Compact Wheel Loader W6T00001-UP (MACHINE) POWERED BY C2.4 Engine

Disassembly and Assembly

C1.7, C1.8 and C2.4 Tier 4 Interim and EU Stage 3A Engines for Caterpillar Built Machines

Media Number -UENR0128-11

Publication Date -01/08/2015

Date Updated -09/06/2016

i05243152

Fuel Injection Lines - Remove and Install

SMCS - 1252-010

Removal Procedure

NOTICE

Keep all parts clean from contaminants.

Contaminants may cause rapid wear and shortened component life.

NOTICE

Care must be taken to ensure that fluids are contained during performance of inspection, maintenance, testing, adjusting and repair of the product. Be prepared to collect the fluid with suitable containers before opening any compartment or disassembling any component containing fluids.

Dispose of all fluids according to local regulations and mandates.

Note: Place identification marks on all tube assemblies for installation. Plug all lines and tube assemblies in order to prevent contamination.

1. Turn the fuel supply to the OFF position.
-

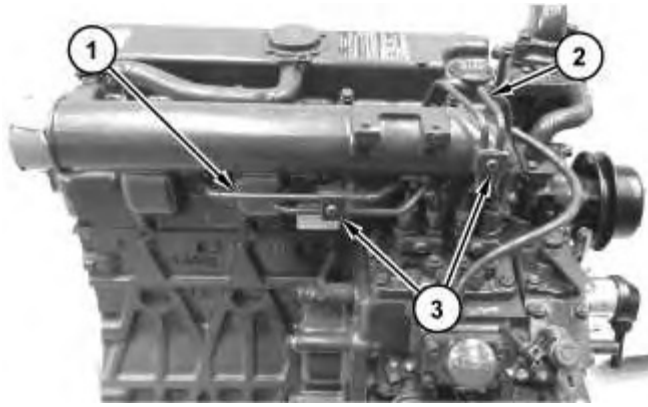

Illustration 1

g02719969

2. If necessary, remove clamp assemblies (3).
3. Remove fuel injection lines (1) and (2) from the engine and the fuel injection pump.
4. Use suitable caps in order to plug the open ports of the fuel injection pump immediately.

Installation Procedure

1. Install fuel injection lines in the reverse order of removal.
 - a. Tighten fuel injection line retaining nut to a torque of 15-24 N·m (11-18 lb ft).

<https://www.ebooklibonline.com>

Hello dear friend!

Thank you very much for reading.

Enter the link into your browser.

The full manual is available for immediate download.

<https://www.ebooklibonline.com>

[Previous Screen](#)

Product: COMPACT WHEEL LOADER

Model: 903C COMPACT WHEEL LOADER W6T

Configuration: 903C Compact Wheel Loader W6T00001-UP (MACHINE) POWERED BY C2.4 Engine

Disassembly and Assembly

C1.7, C1.8 and C2.4 Tier 4 Interim and EU Stage 3A Engines for Caterpillar Built Machines

Media Number -UENR0128-11

Publication Date -01/08/2015

Date Updated -09/06/2016

i05243155

Fuel Injection Nozzles - Remove

SMCS - 1254-011

Removal Procedure

Start By:

- a. Remove the fuel injection lines.

NOTICE

Keep all parts clean from contaminants.

Contaminants may cause rapid wear and shortened component life.

NOTICE

Care must be taken to ensure that fluids are contained during performance of inspection, maintenance, testing, adjusting, and repair of the product. Be prepared to collect the fluid with suitable containers before opening any compartment or disassembling any component containing fluids.

Refer to Special Publication, NENG2500, "Dealer Service Tool Catalog" for tools and supplies suitable to collect and contain fluids on Cat products.

Dispose of all fluids according to local regulations and mandates.

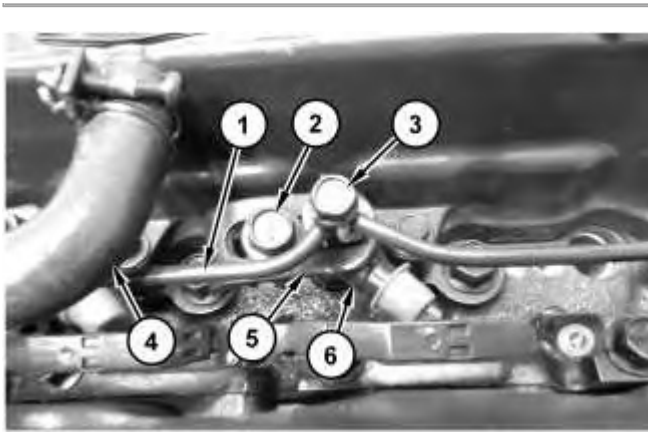

Illustration 1

g02724062

1. If necessary, remove hose assembly (4) and relocate.
2. Remove four bolts (3) and remove tube assembly (1).
3. Remove bolt (2) and hold down clamp (5).
4. Remove fuel injection nozzle (6) from the cylinder head.



Illustration 2

g02724143

5. Remove seat washer (8) from fuel injection nozzle (6). Remove O-ring seal (7). Cap all openings or plug all openings immediately after removal.

Note: Do not reuse seat washer (8) and O-ring seal (7) after removal. Replace the seat washer and the O-ring seal with a new part during installation.

[Previous Screen](#)

Product: COMPACT WHEEL LOADER

Model: 903C COMPACT WHEEL LOADER W6T

Configuration: 903C Compact Wheel Loader W6T00001-UP (MACHINE) POWERED BY C2.4 Engine

Disassembly and Assembly

C1.7, C1.8 and C2.4 Tier 4 Interim and EU Stage 3A Engines for Caterpillar Built Machines

Media Number -UENR0128-11

Publication Date -01/08/2015

Date Updated -09/06/2016

i05243188

Fuel Injection Nozzles - Install

SMCS - 1254-012

Installation Procedure

NOTICE

Keep all parts clean from contaminants.

Contaminants may cause rapid wear and shortened component life.



Illustration 1

g02724143

Note: Do not reuse seat washer (8) and O-ring seal (7) after removal. Replace the seat washer and the O-ring seal with a new part before installation.

1. Install seat washer (8) and O-ring seal (7) onto fuel injector nozzle (6).

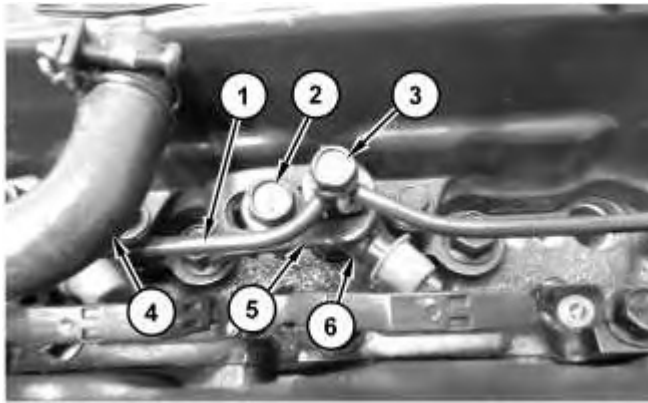

Illustration 2

g02724062

2. Install fuel injection nozzle (6) into the cylinder head.
3. Install hold down clamp (5) and install bolt (2). Tighten the bolts (2) to a torque of 26 to 29 N·m (19 to 21 lb ft).
4. Position tube assembly (1) and install four bolts (3). Tighten the bolts (3) to a torque of 9.8 to 11.2 N·m (86.74 to 99.13 lb in).
5. If necessary, install hose assembly (4).

End By:

- a. Install the fuel injection lines.

[Previous Screen](#)

Product: COMPACT WHEEL LOADER

Model: 903C COMPACT WHEEL LOADER W6T

Configuration: 903C Compact Wheel Loader W6T00001-UP (MACHINE) POWERED BY C2.4 Engine

Disassembly and Assembly

C1.7, C1.8 and C2.4 Tier 4 Interim and EU Stage 3A Engines for Caterpillar Built Machines

Media Number -UENR0128-11

Publication Date -01/08/2015

Date Updated -09/06/2016

i05243376

Governor and Camshaft - Remove

SMCS - 1264-011; 1265-011; 1716-011

Removal Procedure

Start By:

- a. Remove the idler gear.
- b. Remove the fuel injection pump.

NOTICE

Keep all parts clean from contaminants.

Contaminants may cause rapid wear and shortened component life.

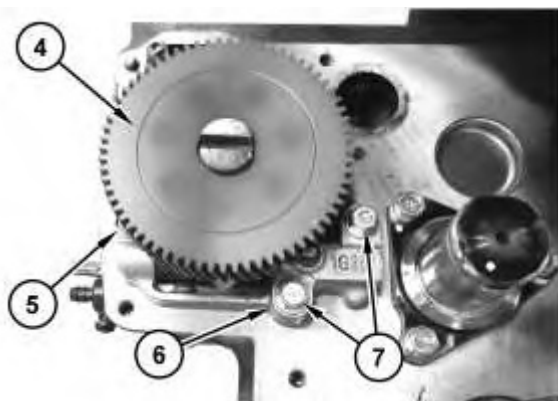

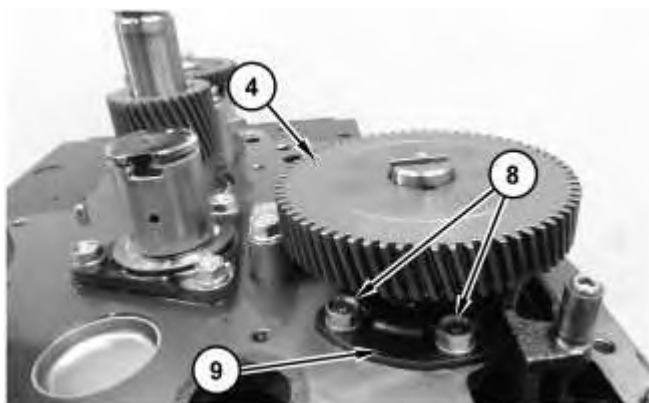

Illustration 2

1. Remove bolts (7) and loosen bolt (5) from bracket (6) from camshaft (4).
2. Remove bolts (8) and bracket (9) that hold the camshaft (4) in the cylinder block.

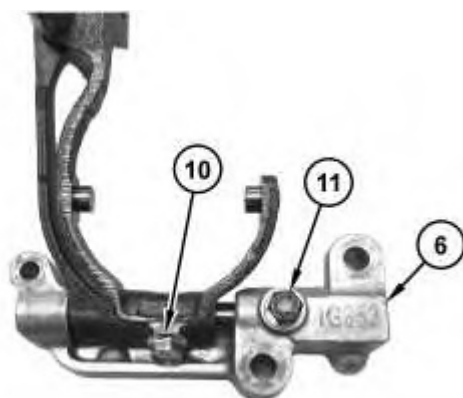

Illustration 3



Illustration 4

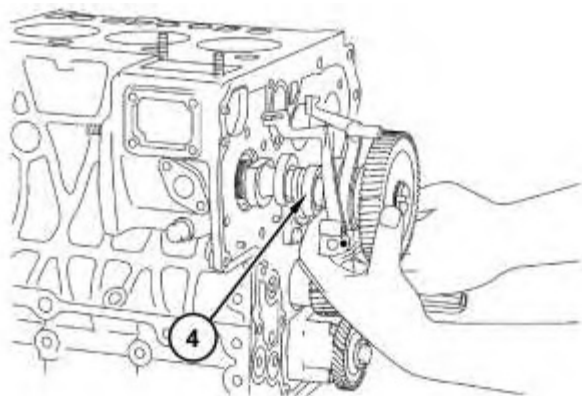

Illustration 5

g02840060

3. Lift camshaft (4) and bracket (6) as one unit.
4. Remove camshaft (4).
5. Remove bolt (10) and the washer. Remove bolt (11) from bracket (6).

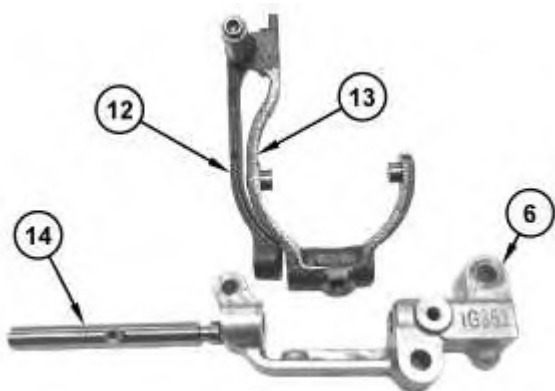

Illustration 6

g02729574

6. Remove shaft (14) from brackets (6), (12), and (13).

[Previous Screen](#)

Product: COMPACT WHEEL LOADER

Model: 903C COMPACT WHEEL LOADER W6T

Configuration: 903C Compact Wheel Loader W6T00001-UP (MACHINE) POWERED BY C2.4 Engine

Disassembly and Assembly

C1.7, C1.8 and C2.4 Tier 4 Interim and EU Stage 3A Engines for Caterpillar Built Machines

Media Number -UENR0128-11

Publication Date -01/08/2015

Date Updated -09/06/2016

i05243388

Governor and Camshaft - Install

SMCS - 1264-012; 1265-012; 1716-012

Installation Procedure

NOTICE

Keep all parts clean from contaminants.

Contaminants may cause rapid wear and shortened component life.

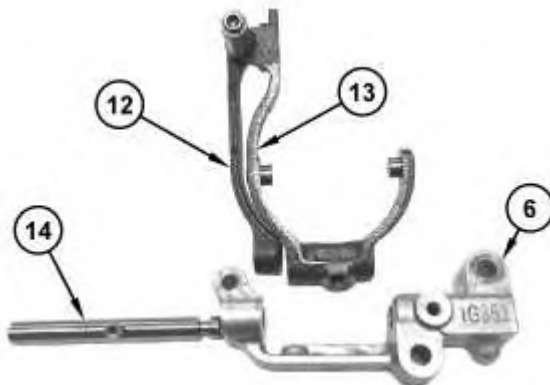

Illustration 1

g02729574

1. Position brackets (13) and (12) in line with bracket (6) and install shaft (14).
-



Illustration 2

g02729844

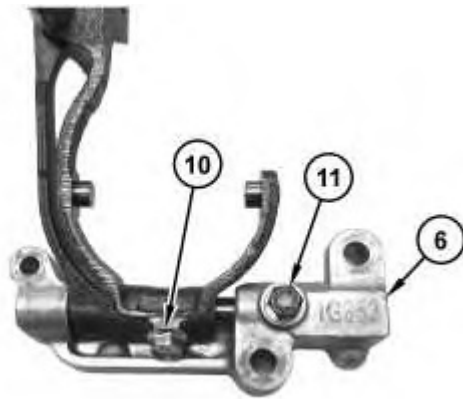

Illustration 3

g02729573

2. Install bolt (11) into bracket (6). Install the washer and bolt (10).
3. Install camshaft (4).
4. Lift camshaft (4) and install bracket (6) as a unit.

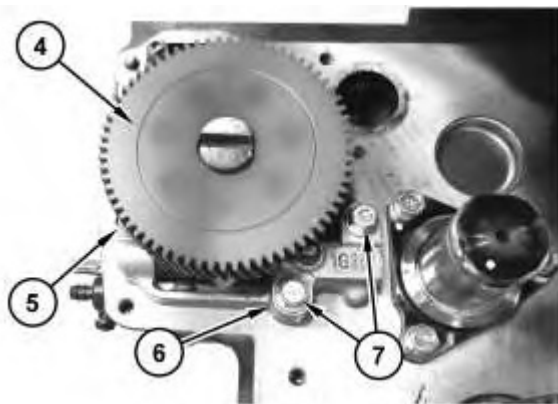

Illustration 4

g02729570

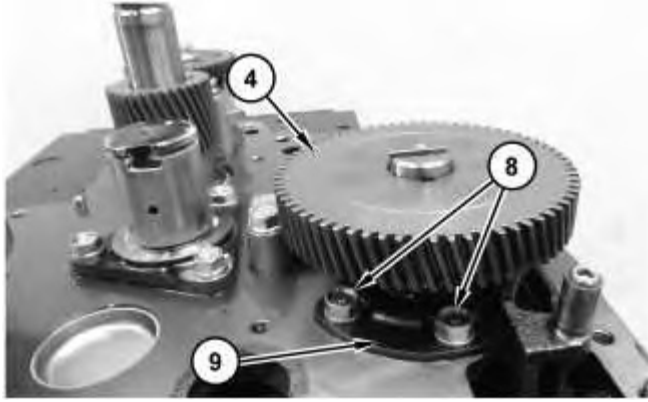

Illustration 5

g02729685

5. Lift camshaft (4). Position bracket (6) and bolt (5).
6. Install bracket (9) and bolts (8).
7. Install bolts (7) and tighten bolt (5) to secure camshaft (4).

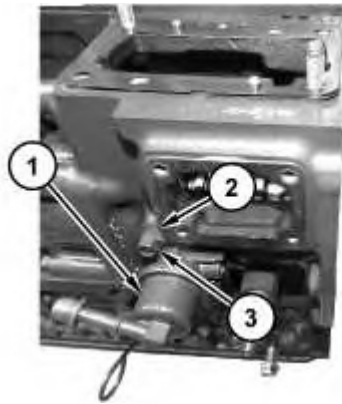

Illustration 6

g02729569

8. Install a new gasket (2) and position supply pump (1). Install bolts (2).

End By:

- a. Install the fuel injection pump.
- b. Install the idler gear.

Previous Screen

Product: COMPACT WHEEL LOADER

Model: 903C COMPACT WHEEL LOADER W6T

Configuration: 903C Compact Wheel Loader W6T00001-UP (MACHINE) POWERED BY C2.4 Engine

Disassembly and Assembly

C1.7, C1.8 and C2.4 Tier 4 Interim and EU Stage 3A Engines for Caterpillar Built Machines

Media Number -UENR0128-11

Publication Date -01/08/2015

Date Updated -09/06/2016

i05243381

Governor and Camshaft - Disassemble

SMCS - 1264-015; 1265-015; 1716-015

Disassembly Procedure

Table 1

Required Tools			
Tool	Part Number	Part Description	Qty
A	8H-0663	Bearing Puller	1

Start By:

- a. Remove governor and camshaft.

NOTICE

Keep all parts clean from contaminants.

Contaminants may cause rapid wear and shortened component life.

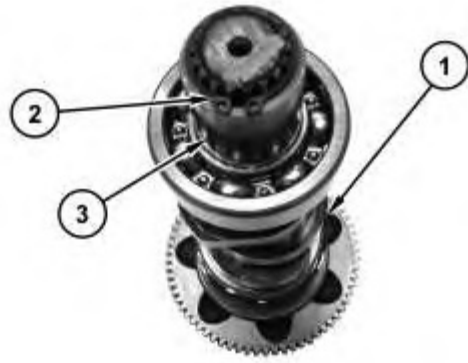

Illustration 1

g02730000

1. Remove retaining ring (2) and sleeve (3) from camshaft (1).
-

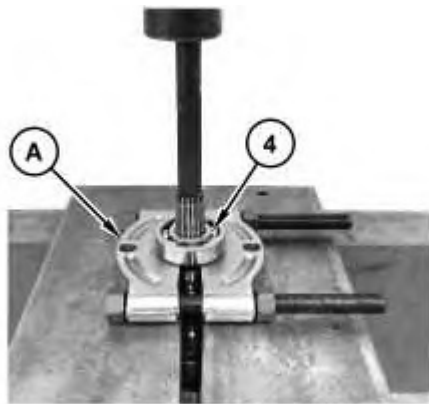

Illustration 2

g02730288

2. Use a suitable press and Tooling (A) to remove bearing (4) from the camshaft.
-

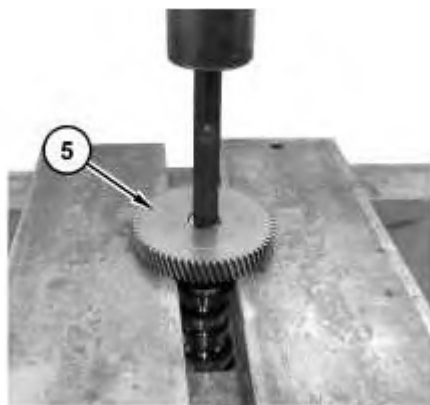

Illustration 3

g02730296

3. Use a suitable press to remove gear (5) from the camshaft.
-



Illustration 4

g02730303

4. Remove key (6) from the camshaft (1).
-

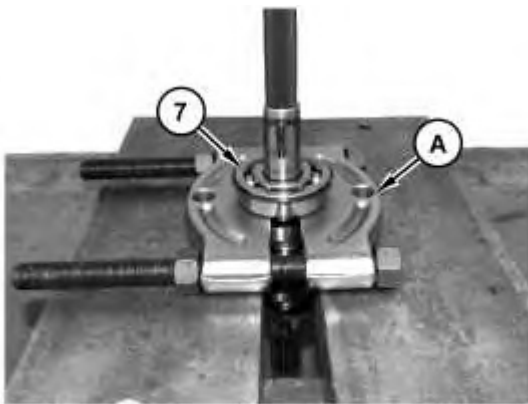

Illustration 5

g02730311

5. Use a suitable press and Tooling (A) to remove bearing (7).
-

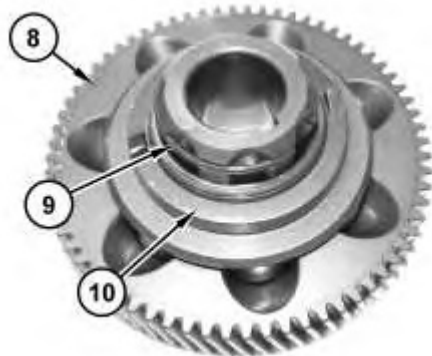

Illustration 6

g02730316

6. Remove retaining ring (9) and remove bearing assembly (10) from gear (8).
-



Illustration 7

g02730320

7. Remove retaining ring (12) from the bearing assembly and remove collier (11).
-

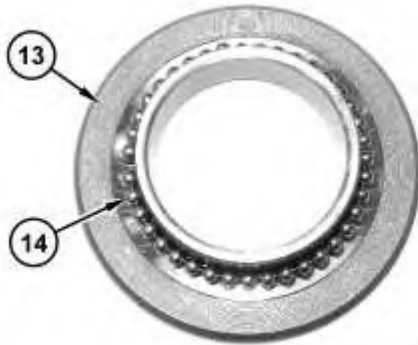

Illustration 8

g02730325

8. Remove bearings (14) from race (13).
-

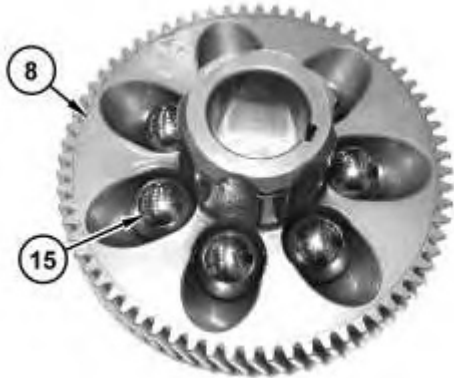

Illustration 9

g02730329

9. Remove ball bearings (15) from gear (8).
-

[Previous Screen](#)

Product: COMPACT WHEEL LOADER

Model: 903C COMPACT WHEEL LOADER W6T

Configuration: 903C Compact Wheel Loader W6T00001-UP (MACHINE) POWERED BY C2.4 Engine

Disassembly and Assembly

C1.7, C1.8 and C2.4 Tier 4 Interim and EU Stage 3A Engines for Caterpillar Built Machines

Media Number -UENR0128-11

Publication Date -01/08/2015

Date Updated -09/06/2016

i05243386

Governor and Camshaft - Assemble

SMCS - 1264-016; 1265-016; 1716-016

Assembly Procedure

Table 1

Required Tools			
Tool	Part Number	Part Description	Qty
A	8H-0663	Bearing Puller	1

NOTICE

Keep all parts clean from contaminants.

Contaminants may cause rapid wear and shortened component life.

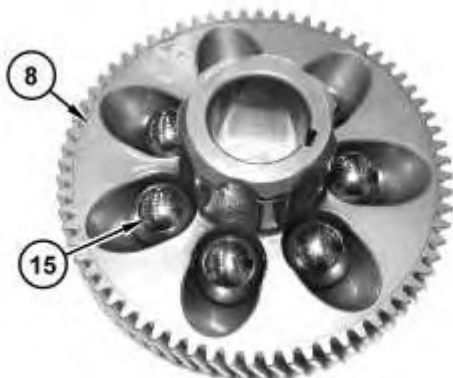

Illustration 1

g02730329

1. Install ball bearings (15) in gear (8).
-

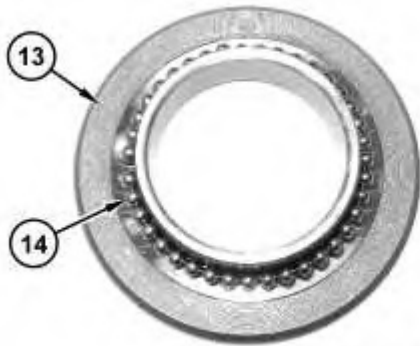

Illustration 2

g02730325

2. Install bearings (14) onto race (13).
-



Illustration 3

g02730320

3. Position collier (11) on the bearing assembly and install retaining ring (12).
-



Illustration 4

g02730316

4. Position bearings assembly (10) onto gear (8) and install retaining ring (9).

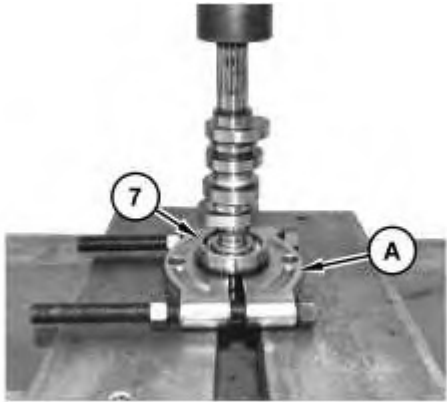

Illustration 5

g02730808

5. Use a suitable press and Tooling (A) to install the bearing (7) on the camshaft.



Illustration 6

g02730303

6. Install key (6) into camshaft (1).

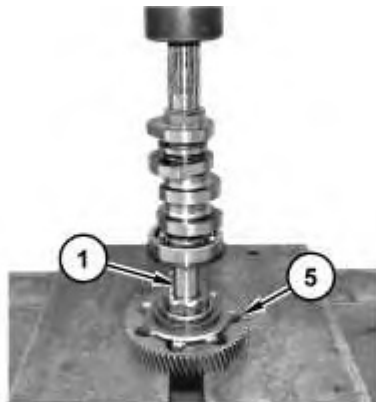

Illustration 7

g02730809

7. Use a suitable press to install gear (5) onto the camshaft.



Illustration 8

g02730810

8. Use a suitable press and Tooling (A) to install the bearing (4) on the camshaft.

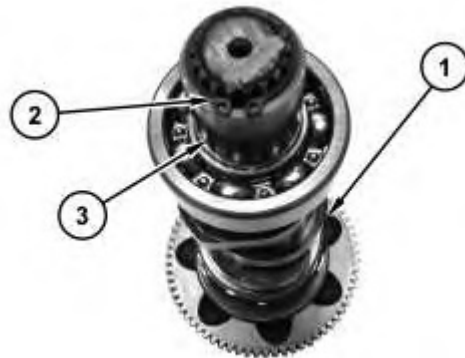

Illustration 9

g02730000

9. Position sleeve (3) on camshaft (1) and install retaining ring (2).

End By:

- a. Install governor and camshaft.

[Previous Screen](#)

Product: COMPACT WHEEL LOADER

Model: 903C COMPACT WHEEL LOADER W6T

Configuration: 903C Compact Wheel Loader W6T00001-UP (MACHINE) POWERED BY C2.4 Engine

Disassembly and Assembly

C1.7, C1.8 and C2.4 Tier 4 Interim and EU Stage 3A Engines for Caterpillar Built Machines

Media Number -UENR0128-11

Publication Date -01/08/2015

Date Updated -09/06/2016

i05243393

Fuel Injection Pump - Remove

SMCS - 1251-011; 1290-011

Removal Procedure

Start By:

- a. Remove inlet manifold.
- b. Remove fuel injection line.

NOTICE

Refer to System Operation, Testing and Adjusting, "Cleanliness of Fuel System Components" for detailed information on the standards of cleanliness that must be observed during ALL work on the fuel system.

1. Turn the fuel supply to the OFF position.
 2. Turn the battery disconnect switch to the OFF position.
-

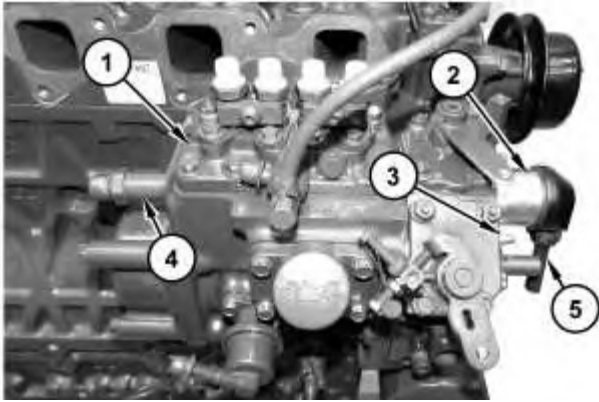

Illustration 1

g02728627

3. Disconnect harness assembly (5) from shut off solenoid (2).
4. Remove nuts (3) and remove shut off solenoid (2) and the O-ring seal from fuel injection pump (1).
5. Remove high idle body (4).

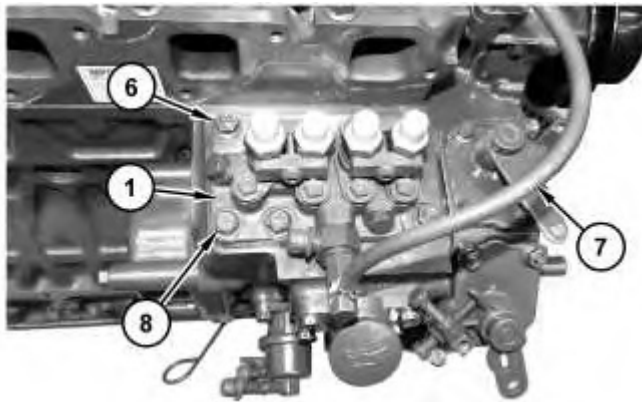

Illustration 2

g02728629

6. Remove two nuts (6) and four bolts (8) from fuel injection pump (1).
 7. Disconnect hose assembly (7) and relocate.
 8. Carefully remove fuel injection pump (1) from the cylinder block housing.
-

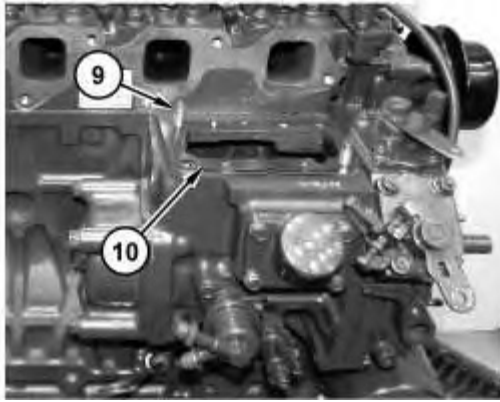

Illustration 3

g02728818

9. Remove gasket shims (10).
10. If necessary, remove studs (9) from the cylinder block housing.
11. Clean fuel injection pump (1) and the area around the fuel injection pump. Ensure that the area is free from contamination before beginning installation.

[Previous Screen](#)

Product: COMPACT WHEEL LOADER

Model: 903C COMPACT WHEEL LOADER W6T

Configuration: 903C Compact Wheel Loader W6T00001-UP (MACHINE) POWERED BY C2.4 Engine

Disassembly and Assembly

C1.7, C1.8 and C2.4 Tier 4 Interim and EU Stage 3A Engines for Caterpillar Built Machines

Media Number -UENR0128-11

Publication Date -01/08/2015

Date Updated -09/06/2016

i05921756

Fuel Injection Pump - Remove

SMCS - 1251-011; 1290-011

Removal Procedure

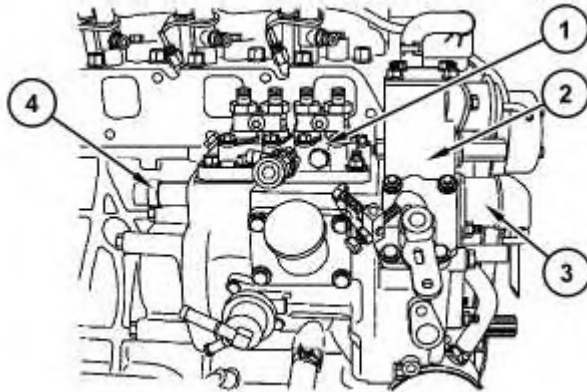
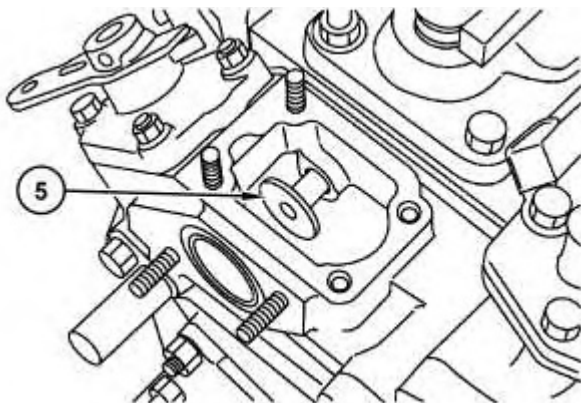

Illustration 1

g03727040



1. Remove boost compensator assembly (2) and high-idling body (4).
2. Remove solenoid guide (5) and injection pump assembly (1).

[Previous Screen](#)

Product: COMPACT WHEEL LOADER

Model: 903C COMPACT WHEEL LOADER W6T

Configuration: 903C Compact Wheel Loader W6T00001-UP (MACHINE) POWERED BY C2.4 Engine

Disassembly and Assembly

C1.7, C1.8 and C2.4 Tier 4 Interim and EU Stage 3A Engines for Caterpillar Built Machines

Media Number -UENR0128-11

Publication Date -01/08/2015

Date Updated -09/06/2016

i05243394

Fuel Injection Pump - Install

SMCS - 1251-012; 1290-012

Installation Procedure

NOTICE

Refer to System Operation, Testing and Adjusting, "Cleanliness of Fuel System Components" for detailed information on the standards of cleanliness that must be observed during ALL work on the fuel system.

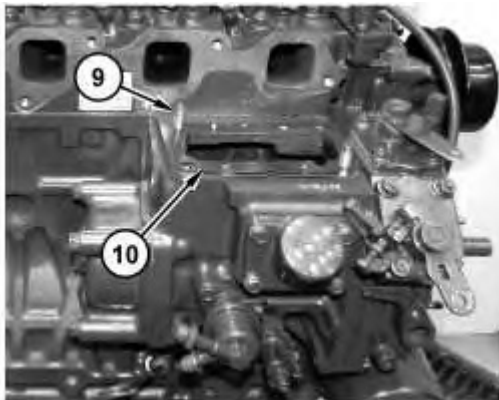

Illustration 1

g02728818

1. If necessary, install studs (9) into the cylinder block housing.
2. Position gasket shims (10) onto the cylinder block housing.

Note: When you disassemble or replace, make sure that you use the same number of new gasket shims with the same thickness.

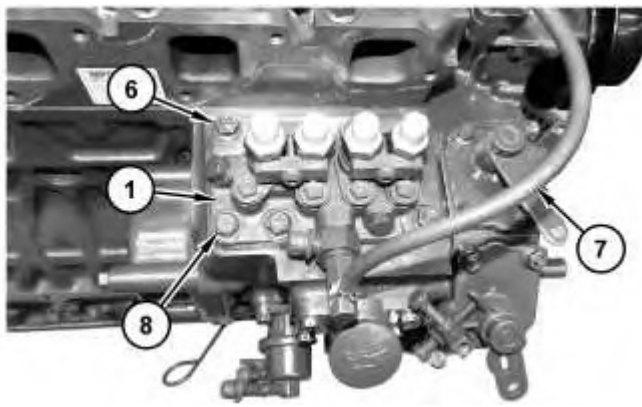

Illustration 2

g02728629

3. Carefully install fuel injection pump (1) into the cylinder block housing .
4. Connect hose assembly (7).
5. Install four new bolts (8) into fuel injection pump (1). Install two nuts (6) into fuel injection pump (13).

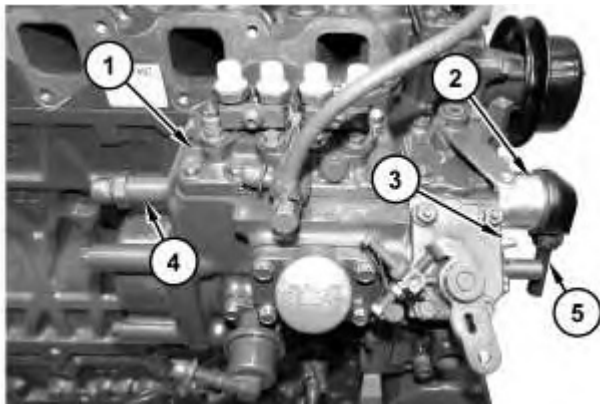

Illustration 3

g02728627

6. Install high idle body (4) with new gasket into the cylinder block housing and fuel injection pump (1). Tighten high idle body (4) to a torque of 45 to 49 N·m (33 to 36 lb ft).
7. Install a new O-ring seal on shut off solenoid (2). Position shut off solenoid (2) and install nuts (3).
8. Connected harness assembly (5) to shut off solenoid (2).
9. Turn the fuel supply to the ON position.
10. Turn the battery disconnect switch to the ON position.



Suggest:

If the above button click is invalid.

Please download this document

first, and then click the above link

to download the complete manual.

Thank you so much for reading

11. After replacement of the fuel injection pump, the fuel injection pump must be calibrated. Refer to System Operation, Testing and Adjusting, "Fuel Injection Timing - Check".

End By:

- a. Install fuel injection lines.
- b. Install inlet manifold.

Copyright 1993 - 2019 Caterpillar Inc.

Sat Aug 31 11:29:24 UTC+0800 2019

All Rights Reserved.

Private Network For SIS Licensees.

<https://www.ebooklibonline.com>

Hello dear friend!

Thank you very much for reading.

Enter the link into your browser.

The full manual is available for immediate download.

<https://www.ebooklibonline.com>