



# Service Repair Manual

## **Models**

385B and 385B L Excavator

---

[Previous Screen](#)

Product: EXCAVATOR

Model: 385B EXCAVATOR BKF

Configuration: 385B &amp; 385B L Excavators BKF00001-UP (MACHINE) POWERED BY 3456 Engine

## Disassembly and Assembly 385B and 5090B Excavators Excavator Systems

Media Number -REN5407-06

Publication Date -01/02/2016

Date Updated -12/02/2016

i01674800

# Final Drive - Disassemble

SMCS - 4050-015

## Disassembly Procedure

Table 1

Required Tools			
Tool	Part Number	Part Description	Qty
A	1P-2420	Transmission Repair Stand	1
B	138-7575	Link Bracket	3
C	138-7576	Link Bracket	2
D	132-8119	Hydraulic Wrench	1
	132-8223	Hydraulic Pump and Motor Gp	1
	9U-7418	Hex Bit Socket	1
E	176-6536	Forcing Bolt	2

### Start By:

- a. Remove the final drive. Refer to Disassembly and Assembly, "Final Drive - Remove".
    1. Thoroughly clean the outside of the final drive prior to disassembly.
-



Illustration 1

g00865168

2. Fasten the final drive to Tooling (A). Put an alignment mark across the sections of the final drive for assembly purposes. All parts must be reinstalled in the original locations. The weight of the final drive is approximately 1020 kg (2250 lb).

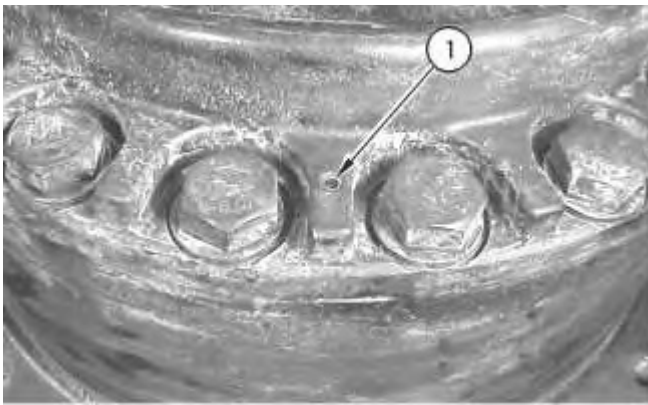

Illustration 2

g00865172

3. Remove socket head bolts (1) from the final drive cover.



Illustration 3

g00865173

4. Fasten Tooling (B) and a suitable lifting device to cover (2).

**<https://www.ebooklibonline.com>**

Hello dear friend!

Thank you very much for reading.

Enter the link into your browser.

The full manual is available for immediate download.

**<https://www.ebooklibonline.com>**

- Remove bolts (3). Use a soft faced hammer to break the seal between the cover and the ring gear. Remove cover (2). The weight of the cover is approximately 95 kg (210 lb).

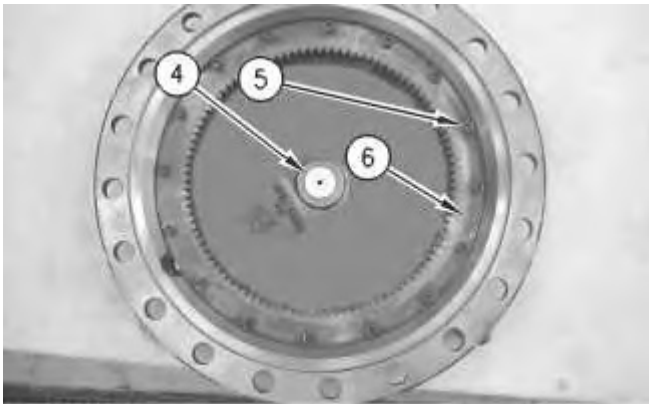

Illustration 4

g00865183

- Remove spacer (4) and the shims from the cover.
- Remove socket head bolts (5) and ring gear (6) from the cover.

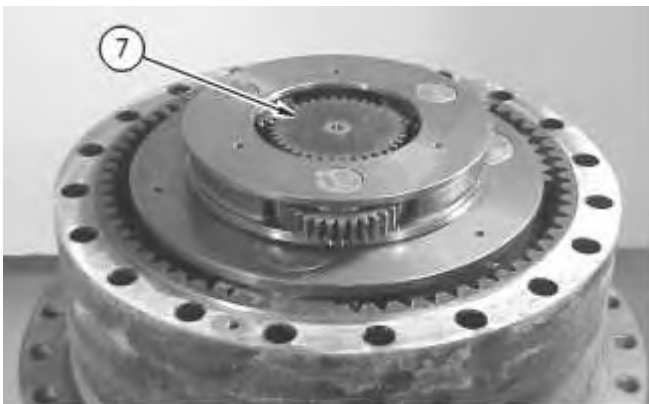

Illustration 5

g00865487

- Remove sun gear (7).



Illustration 6

g00865501

9. Use a hoist and Tooling (B) to remove carrier assembly (8). The weight of the carrier assembly is approximately 43 kg (95 lb).



Illustration 7

g00865534

10. Remove retaining ring (9), spacer (10), and sun gear (11).

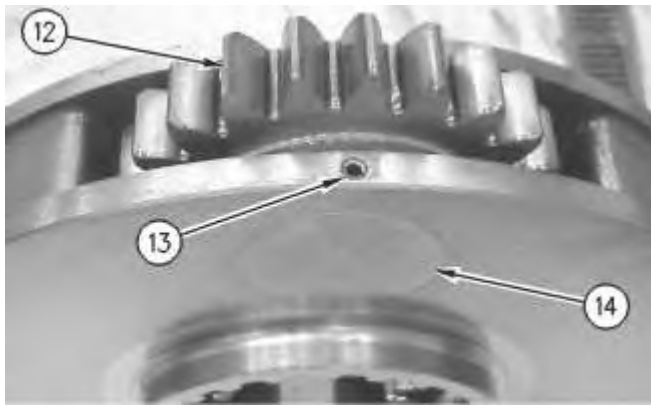

Illustration 8

g00865551

11. Drive spring pin (13) into shaft (14). Remove shaft (14) and gear assembly (12).

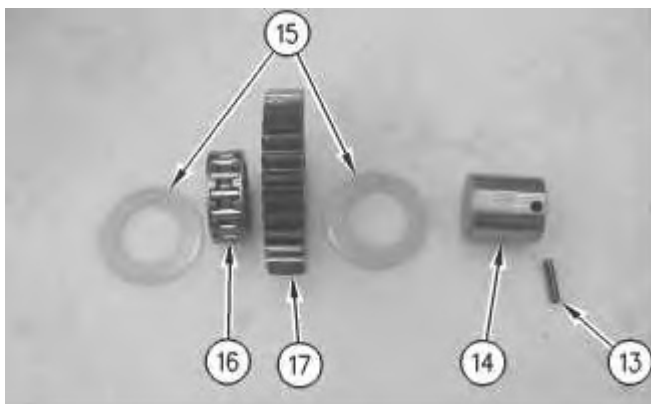

Illustration 9

g00865614

12. Remove washers (15) and bearing (16) from gear (17). Remove spring pin (13) from shaft (14).
13. Repeat Steps 11 and 12 for the remaining gear assemblies.



Illustration 10

g00865671

14. Use a hoist and Tooling (B) to remove carrier assembly (18). The weight of the carrier assembly is approximately 95 kg (210 lb).

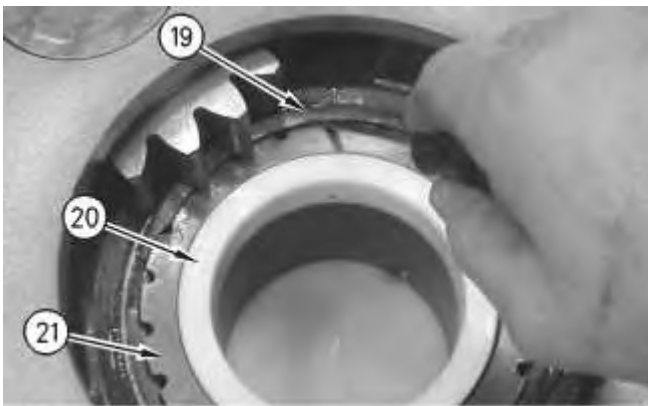
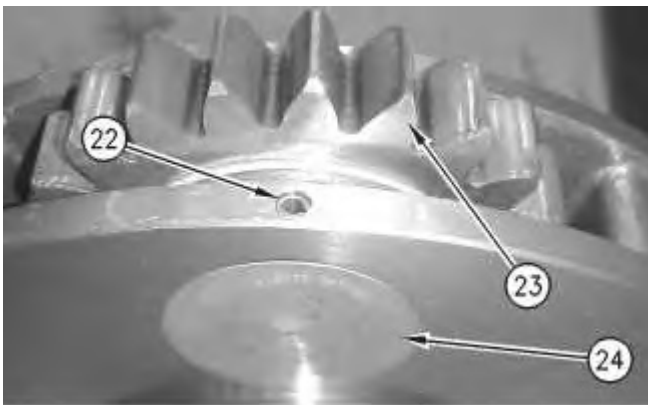

Illustration 11

g00865717

15. Remove retaining ring (19), spacer (20), and gear assembly (21).



16. Drive spring pin (22) into planetary shaft (24). Remove planetary shaft (24) and gear assembly (23).

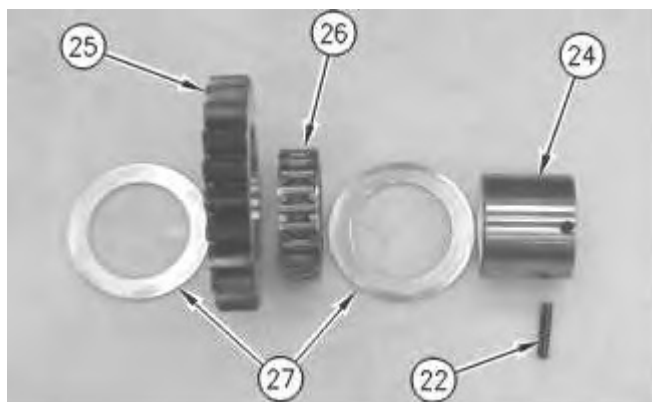

Illustration 13

17. Remove thrust washers (27) and bearing (26) from planetary gear (25). Remove spring pin (22) from shaft (24).
18. Repeat Steps 16 and 17 for the remaining gear assemblies.

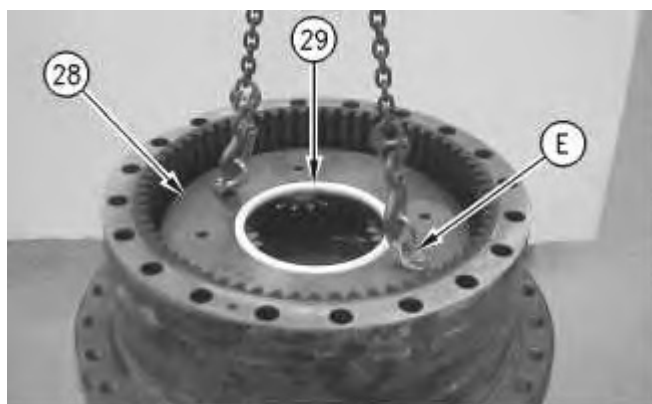

Illustration 14

19. Use a hoist and Tooling (B) to remove carrier assembly (28). The weight of the carrier assembly is approximately 132 kg (290 lb). Remove spacer (29).
-

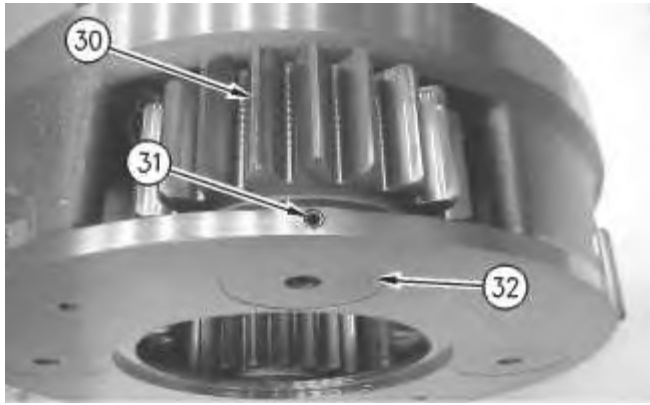

Illustration 15

g00865872

20. Drive spring pin (31) into shaft (32). Remove planetary shaft (32) and gear assembly (30).

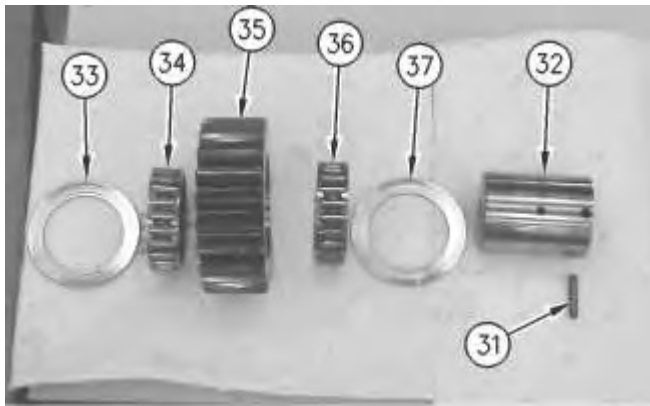

Illustration 16

g00865884

21. Remove thrust washers (33) and (37), and bearings (34) and (36) from planetary gear (35). Remove spring pin (31) from shaft (32).
22. Repeat Steps 20 and 21 for the remaining gear assemblies.



Illustration 17

g00865931

23. Use a hoist and Tooling (B) to remove ring gear (38) from housing (39). The weight of the ring gear is approximately 155 kg (340 lb).



Illustration 18

g00865939

24. Remove O-ring seal (40) from the main housing.



Illustration 19

g00865955

25. Place wood blocks under the final drive in order to support the motor housing.

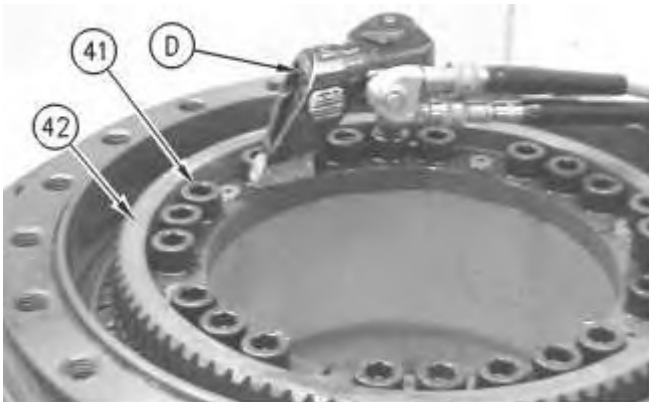

Illustration 20

g00866047

---

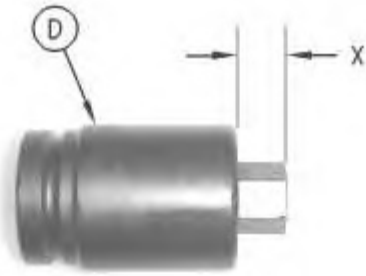

Illustration 21

g00865969

26. Use Tooling (D) to remove bolts (41) from gear (42).

**Note:** A part of Tooling (D) must be modified. Cut Length (X) on a **9U-7418** Hex Bit Socket to a length of 14 mm (0.55 inch).

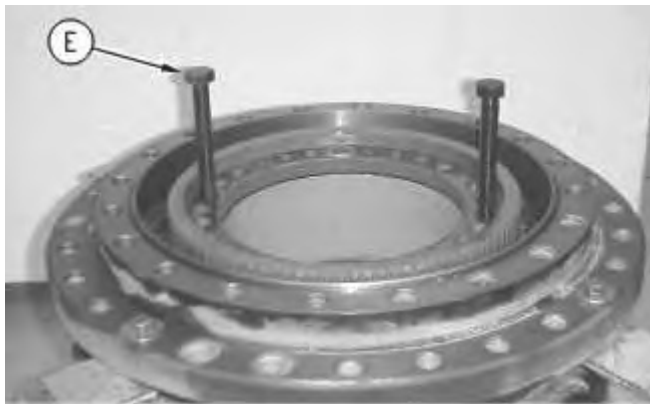

Illustration 22

g00866066

27. Install Tooling (E) in the gear, as shown. Tighten Tooling (E) evenly in order to loosen the gear. Remove the gear from the motor housing.



Illustration 23

g00866072

28. Remove shims (43) from the motor housing.



Illustration 24

g00866085

29. Remove bolts (44). Use Tooling (C) and a hoist to separate main housing (45) from motor housing (39). The motor housing will rest on the wood blocks. The weight of the main housing is approximately 250 kg (550 lb).



Illustration 25

g00866095

30. Remove bearing (46) from the main housing.



Illustration 26

g00866100

31. Remove Duo-Cone seal (47), and bearing cups (48) and (49) from the main housing.



Illustration 27

g00866156

32. Remove pins (50), if necessary.

33. Remove bearing (51).

34. Remove Duo-Cone seal (52) from the motor housing.

[Previous Screen](#)

Product: EXCAVATOR

Model: 385B EXCAVATOR BKF

Configuration: 385B &amp; 385B L Excavators BKF00001-UP (MACHINE) POWERED BY 3456 Engine

## Disassembly and Assembly 385B and 5090B Excavators Excavator Systems

Media Number -REN5407-06

Publication Date -01/02/2016

Date Updated -12/02/2016

i01678933

## Final Drive - Assemble

SMCS - 4050-016

## Assembly Procedure

Table 1

Required Tools			
Tool	Part Number	Part Description	Qty
A	1P-2420	Transmission Repair Stand	1
B	138-7576	Link Bracket	3
C	205-8241	Installer	1
D	132-8119	Hydraulic Wrench	1
	132-8223	Hydraulic Pump and Motor Gp	1
	9U-7418	Hex Bit Socket	1
E	138-7575	Link Bracket	3
F	6V-3175	Double Acting Cylinder	1
	3S-6224	Electric Hydraulic Pump Gp	1
	1U-9889	Crossblock	1
	9S-7338	Crossblock	1
	150-1961	Washer	2
	150-1786	Plate	2
	4C-9634	Puller Stud	1
	9U-6832	Nut	1

	2K-7468	Locknut	1
	4K-0684	Locknut	2
	6V-2078	Stud	2
	5P-4807	Cap	2
G	138-7575	Link Bracket	2

1. Make sure that all parts of the final drive are thoroughly clean and free of dirt and debris prior to assembly.

**Note:** Check the condition of all the O-ring seals that are used in the final drive. If any of the seals are worn or damaged, use new parts for replacement.

2. Reassemble the final drive on wood blocks and Tooling (A).



Illustration 1

g00875656

3. Apply **5P-3931** Anti-Seize Compound to the surfaces that contact the bearing cones. Install the bearing cone with a press. Raise the temperature of bearing (51) and install the bearing.
4. Apply **5P-3931** Anti-Seize Compound to the surfaces that contact pins (50). Install the pins.

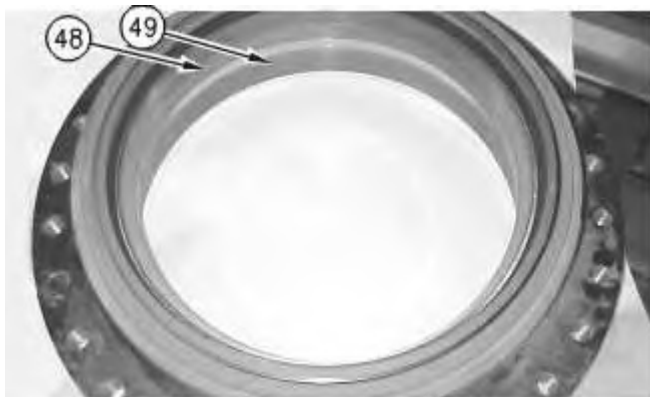

Illustration 2

g00875674

5. Apply **5P-3931** Anti-Seize Compound to the surfaces that contact the two bearing cups. Install bearing cups (48) and (49).



Illustration 3

g00875677

6. Use Tooling (B) and a suitable lifting device to install main housing (45) on motor housing (39). The weight of the main housing is approximately 250 kg (550 lb).



Illustration 4

g00875859

7. Install bearing (46) and the bearing cone.
8. Use the following procedure to determine the bearing preload and the correct number of shims.

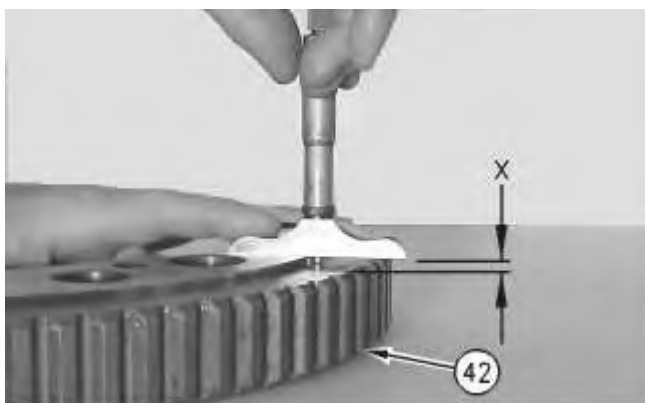

- a. Use a depth micrometer in order to measure the step length of the coupling gear (42). Take measurements at several different locations around the gear. Compute the average of the measured dimensions and record the number. Call this Dimension (X).

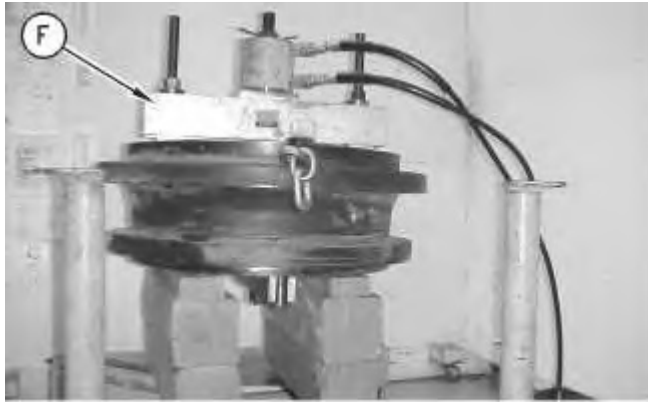

Illustration 6

g00876170

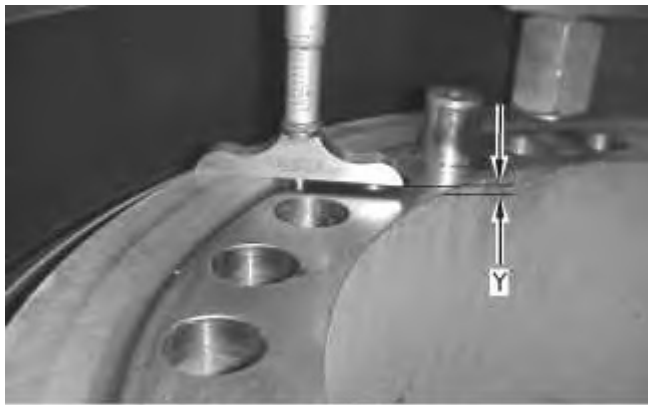

Illustration 7

g00876133

- b. Use Tooling (F) to apply a load of 10700 kPa (1550 psi) in order to seat the bearings. A pressure of 10700 kPa (1550 psi) on the **3S-6224** Electric Hydraulic Pump Gp will result in a pressure of 10000 kg (22050 lb) on the bearings. Rotate the housing in order to seat the bearing. Reduce the load on the **3S-6224** Electric Hydraulic Pump Gp to 4825 kPa (700 psi).
- c. Rotate Tooling (F) by 90° and repeat Step 8.b.
- d. Maintain the load on the bearings. Use a depth micrometer and measure the distance between the top face of motor housing and the bearing cone. Take this measurement in several locations around the bearing. Compute the average of the measured dimensions and record the number. Call this Dimension (Y).
- e. Determine the correct thickness of the shim pack that will be installed between the bearing cone and the coupling gear. The shim pack thickness is equal to Dimension (Y) minus Dimension (X). Tolerance for the shim pack is 0.1 mm (0.003 inch).

**Note:** If two shims are required, install the thinner shim next to the coupling gear when the coupling gear is installed.

9. Use Tooling (B) and a suitable lifting device to remove the main housing from the motor housing. The weight of the main housing is approximately 250 kg (550 lb).

**Note:** Refer to Disassembly and Assembly, "Duo-Cone Conventional Seals - Install".

**Note:** The rubber seals and all surfaces that contact the seals must be clean and dry. After installation of the seals, apply clean SAE 30 oil on the contact surfaces of the metal seals.



---

Illustration 8

g00876775

10. Use Tooling (C) to install Duo-Cone seal (47) in the main housing.



---

Illustration 9

g00876788

11. Use Tooling (C) to install Duo-Cone seal (52) in the motor housing.

**Note:** Make sure that the Duo-Cone seals are not scratched or damaged during the assembly of the main housing or during the assembly of the motor housing. After installation of the main housing on the motor housing, there will be a small gap between the components. The gap is caused by the Duo-Cone seals. The gap will be eliminated during installation of the gear.

---



Illustration 10

g00875677

12. Fasten Tooling (B) and a hoist to main housing (45). Place the main housing in position on motor housing (39). Make sure that the Duo-Cone seals are not scratched or damaged during installation. The weight of the main housing is approximately 250 kg (550 lb).

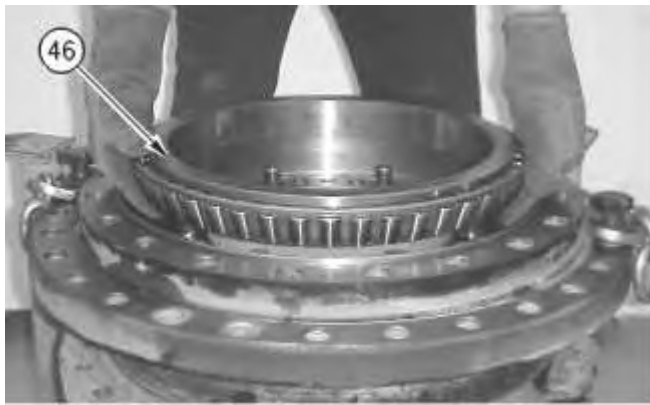

Illustration 11

g00876801

13. Install bearing (46) and the bearing cone.



Illustration 12

g00866072

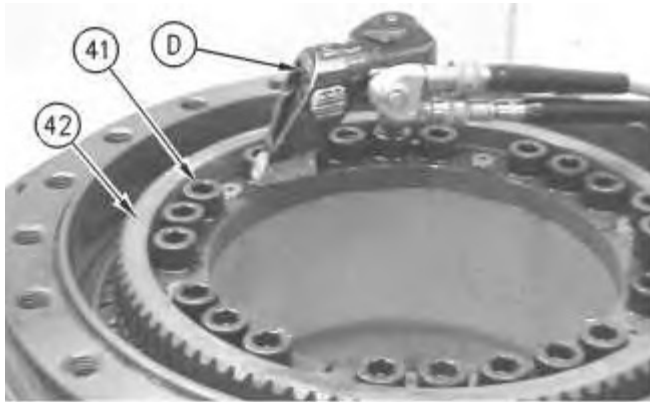

Illustration 13

g00866047

14. Place shims (43) in the correct position on the motor housing. If two shims were required, put the thinner shim in contact with coupling gear (42). Make sure that all of the holes in the components are in alignment with each other. Put coupling gear (42) in the original position on the motor housing.
15. Apply **9S-3263** Thread Lock Compound on the threads of bolts (41). Install the bolts to secure coupling gear (42) in place. Tighten the bolts evenly and tighten the bolts in diagonally opposite pairs. Tighten bolts to a torque of  $900 \pm 100$  N·m ( $665 \pm 75$  lb ft).



Illustration 14

g00865939

16. Install O-ring seal (40) in the main housing.



17. Use Tooling (B) and a hoist to position housings (39) and (45) on Tooling (A). Remove the wood blocks. The weight of both housings is approximately 430 kg (950 lb).



Illustration 16

18. Thoroughly clean the mating surface of main housing (39) that contacts ring gear (38). Apply a bead of **1U-8846** Gasket Sealant on the mating surface of ring gear (38). Use Tooling (E) and a suitable lifting device. Place the ring gear in position on the main housing. Make sure that the alignment mark on the main housing and the ring gear line up with each other. It may be necessary to use a soft faced hammer to seat the ring gear on the main housing.
19. Assemble carrier assembly (28), as follows:

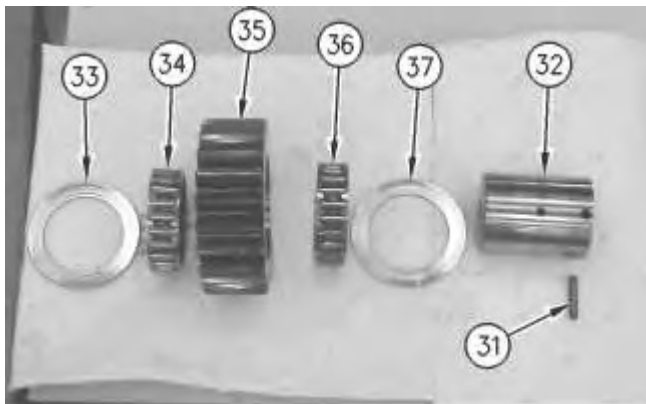

Illustration 17

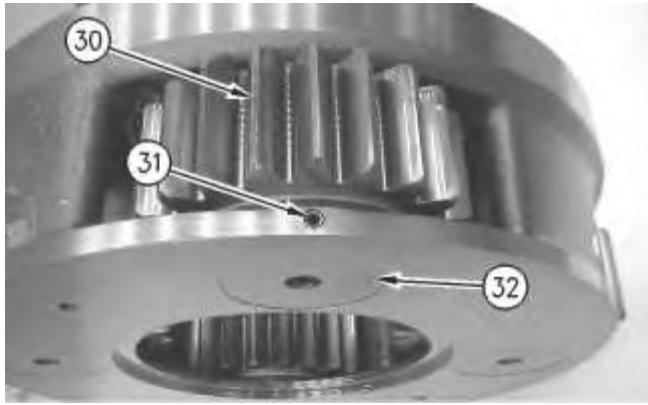

Illustration 18

g00865872

- a. Apply clean SAE 30 oil on bearings (34) and (36). Install two bearings (34) and (36) in planetary gear (35).
- b. Install thrust washers (33) and (37) on each side of the planetary gear.
- c. Install the planetary gear and thrust washers in carrier assembly (28).
- d. Install planetary shaft (32) in carrier assembly (28) and through planetary gear assembly (30). Make sure that the spring pin hole in the planetary shaft is in alignment with the spring pin hole in the carrier.

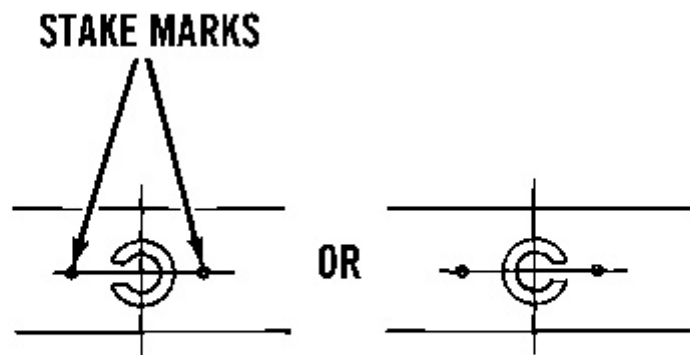

Illustration 19

g00513451

- e. Install spring pin (31) in the carrier and into the planetary shaft. Make sure that the spring pin hole in the planetary shaft is in alignment with the spring pin hole in the carrier.
- f. Orient the split in spring pin (31) horizontally to the carrier. Align the split in the spring pin to the left or to the right. Make a stake mark on each side of the spring pin hole in the carrier. This will prevent the spring pin from falling out of the spring pin

hole. Each stake mark should be approximately 1.5 mm (0.06 inch) to 3.00 mm (0.118 inch) from the outside diameter of the spring pin hole.

- g. Repeat Steps 19.a through 19.f in order to install the other three planetary gears in carrier assembly (28).

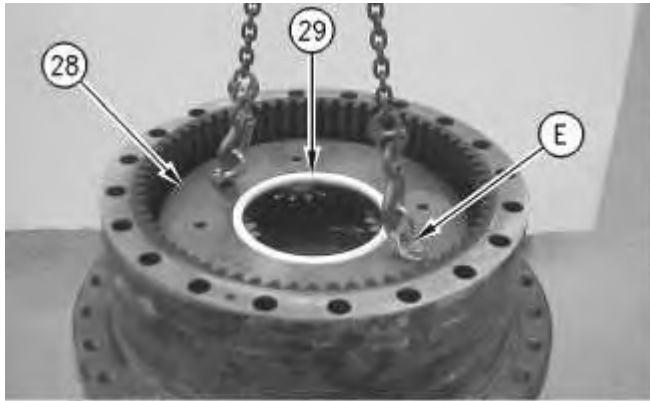

Illustration 20

g00865862

20. Fasten Tooling (E) and a hoist to carrier assembly (28). Put the carrier assembly in position in the ring gear. It may be necessary to move the carrier assembly back and forth during installation in order to ensure that all gears engage properly.
21. Install spacer (29).
22. Assemble carrier assembly (21), as follows:

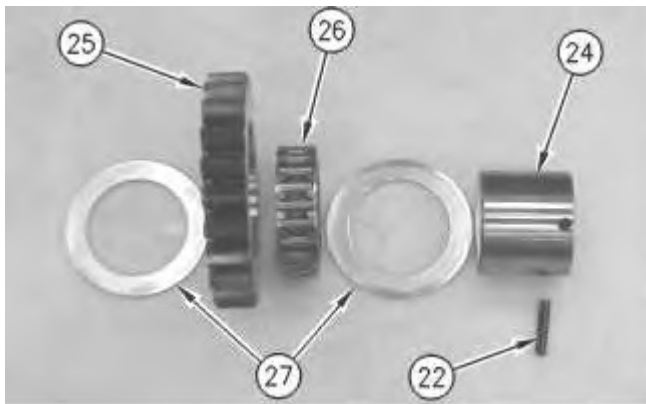

Illustration 21

g00865753

- a. Apply clean SAE 30 oil on bearing (26). Install bearing (26) in planetary gear (25).
  - b. Install thrust washers (27) on each side of the planetary gear.
  - c. Install the thrust washers and the planetary gear in carrier assembly (28).
-

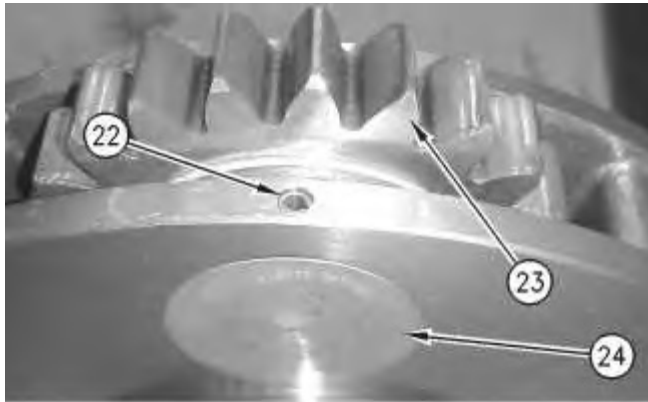

Illustration 22

g00865736

- d. Install planetary shaft (24) in carrier assembly (28) and through the planetary gear assembly. Make sure that the spring pin hole in the planetary shaft is in alignment with the spring pin hole in the carrier.

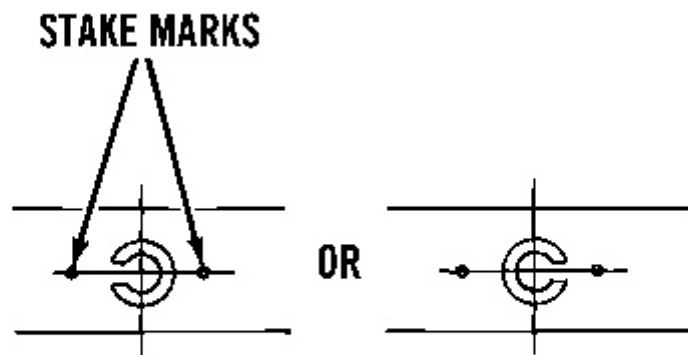

Illustration 23

g00513451

- e. Orient the split in the spring pin (22) horizontally to the carrier. Align the split in the spring pin to the left or to the right. Make a stake mark on each side of the spring pin hole in the carrier. This will prevent the spring pin from falling out of the spring pin hole. Each stake mark should be approximately 1.5 mm (0.06 inch) to 3.00 mm (0.118 inch) from the outside diameter of the spring pin hole.
- f. Repeat Steps 22.a through 22.e in order to install the other two planetary gears in carrier assembly (28).

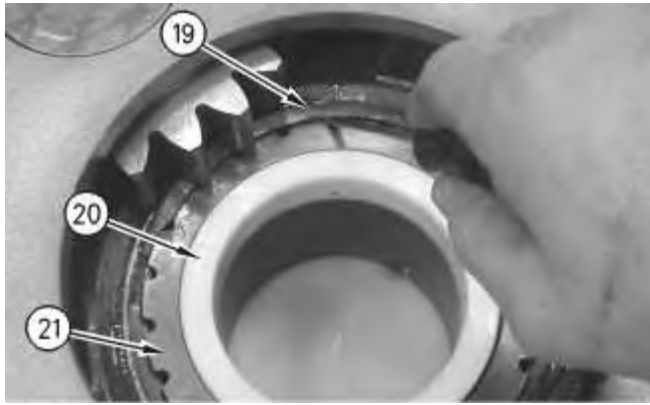

Illustration 24

g00865717

23. Install gear assembly (21), spacer (20), and retaining ring (19).



Illustration 25

g00865671

24. Use a hoist and Tooling (B) to install carrier assembly (18). The weight of the carrier assembly is approximately 95 kg (210 lb).

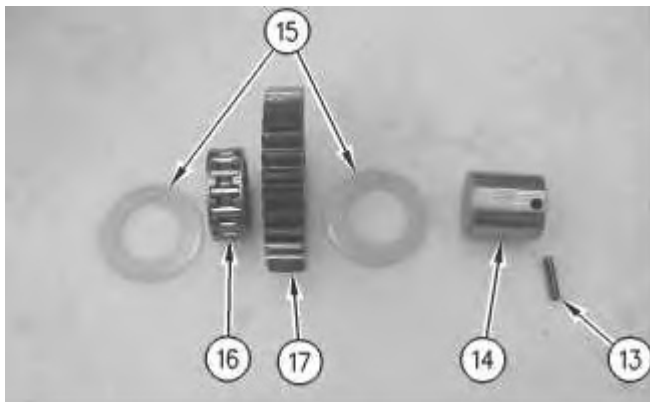

Illustration 26

g00865614

25. Apply clean SAE 30 oil on bearing (16). Install washers (15) and bearing (16) in gear (17).

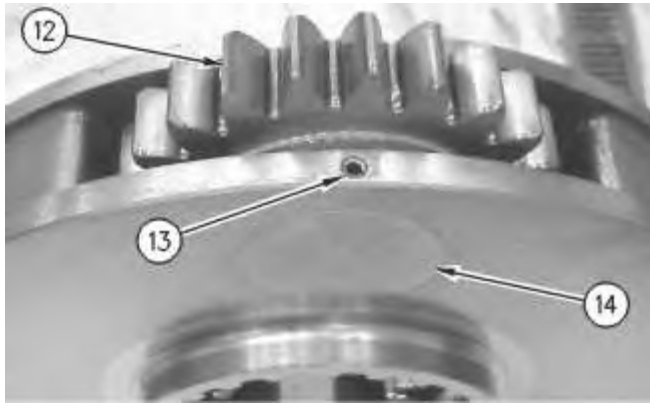

Illustration 27

g00865551

26. Install gear assembly (12), shaft (14), and drive spring pin (13) into shaft (14).
27. Repeat Steps 25 and 26 for the remaining gear assemblies.



Illustration 28

g00865534

28. Install sun gear (11), spacer (10), and retaining ring (9).



Illustration 29

g00865501

29. Use a hoist and Tooling (B) to install carrier assembly (8). The weight of the carrier assembly is approximately 43 kg (95 lb).



**Suggest:**

**If the above button click is invalid.**

**Please download this document**

**first, and then click the above link**

**to download the complete manual.**

**Thank you so much for reading**

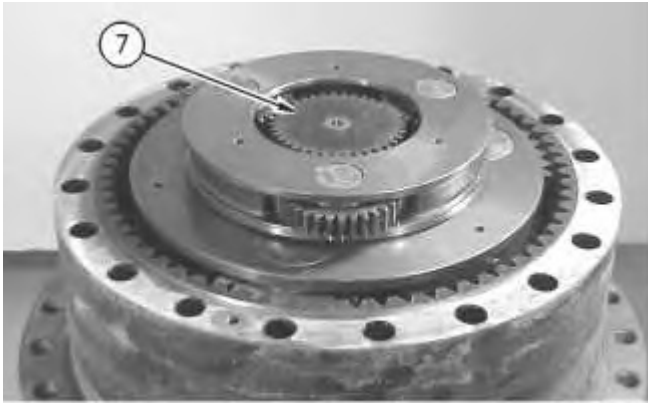

Illustration 30

g00865487

30. Install sun gear (7).

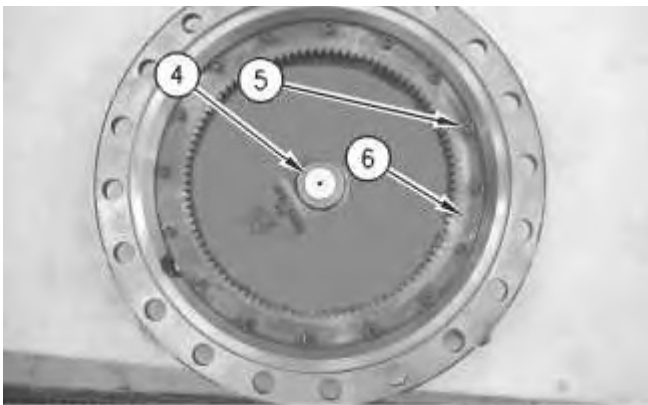

Illustration 31

g00865183

31. Install the shims and spacer (4) in the cover.
32. Install ring gear (6) and socket head bolts (5) in the cover.



Illustration 32

g00865173

33. Use Tooling (B) and a suitable lifting device to position cover (2). Install bolts (3). The weight of the cover is approximately 95 kg (210 lb).

**<https://www.ebooklibonline.com>**

Hello dear friend!

Thank you very much for reading.

Enter the link into your browser.

The full manual is available for immediate download.

**<https://www.ebooklibonline.com>**