



Service Repair Manual

Models

365C and 365C L Excavator

[Previous Screen](#)

Product: EXCAVATOR

Model: 365C EXCAVATOR MCS

Configuration: 365C L Excavator MCS00001-UP (MACHINE) POWERED BY C-15 Engine

Disassembly and Assembly 365C Excavator Machine Systems

Media Number -REN8616-03

Publication Date -01/08/2012

Date Updated -24/08/2012

i02388153

Final Drive - Disassemble

SMCS - 4050-015

Disassembly Procedure

Table 1

Required Tools			
Tool	Part Number	Part Description	Qty
A	1P-2420	Transmission Repair Stand	1
B	138-7575	Link Bracket	3
C	138-7576	Link Bracket	2
D	132-8119	Hydraulic Wrench	1
	132-8223	Hydraulic Pump and Motor Gp	1
	9U-7418	⁽¹⁾ Hex Bit Socket	1
E	176-6536	Forcing Bolt	2

⁽¹⁾ Cut the tool to length (X). Length (X) is equal to 14 mm (0.55 inch). Refer to Step 27 for the correct modification.

Start By:

- A. Remove the final drive. Refer to Disassembly and Assembly, "Final Drive - Remove".
 1. Thoroughly clean the outside of the final drive prior to disassembly.
-



Illustration 1

g00865168

2. Fasten the final drive to Tooling (A). Put an alignment mark across the sections of the final drive for assembly purposes. All parts must be reinstalled in the original locations. The weight of the final drive is approximately 817 kg (1800 lb).

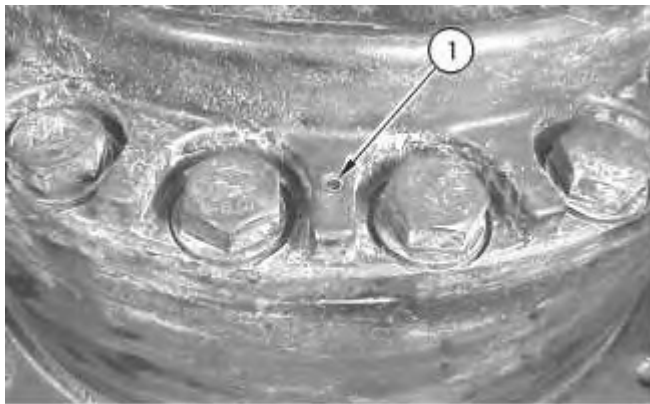

Illustration 2

g00865172

3. Remove socket head bolts (1) from the final drive cover.

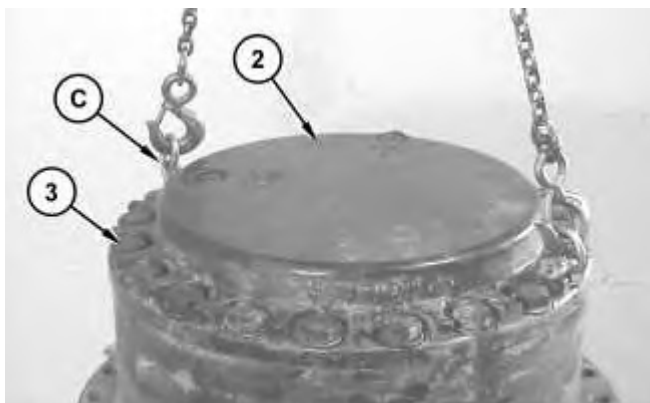

Illustration 3

g01192344

<https://www.ebooklibonline.com>

Hello dear friend!

Thank you very much for reading.

Enter the link into your browser.

The full manual is available for immediate download.

<https://www.ebooklibonline.com>

4. Attach Tooling (C) and a suitable lifting device to cover (2). The weight of cover (2) is approximately 66 kg (145 lb).
5. Remove bolts (3). Use a suitable hammer to break the seal between cover (2) and the ring gear. Remove cover (2).

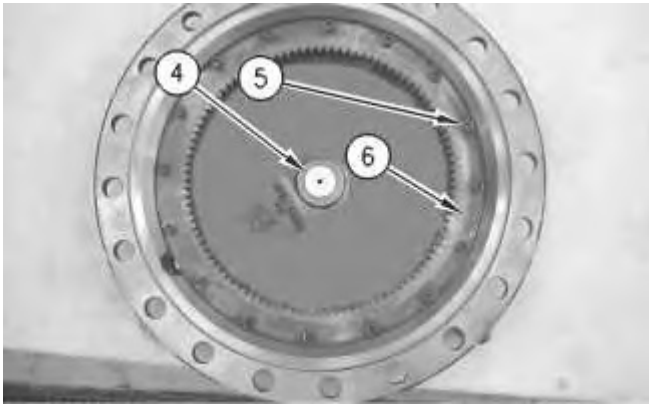

Illustration 4

g00865183

6. Remove spacer (4) and the shims from the cover.
7. Remove socket head bolts (5) and ring gear (6) from the cover.



Illustration 5

g00865487

8. Remove sun gear (7) .
-



Illustration 6

g00865501

9. Use Tooling (B) and a suitable lifting device to remove carrier assembly (8). The weight of carrier assembly (8) is approximately 30 kg (55 lb).

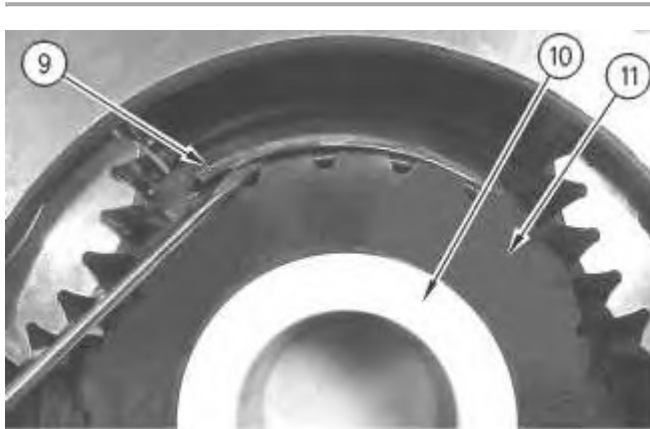

Illustration 7

g00865534

10. Remove retaining ring (9), spacer (10), and sun gear (11) .

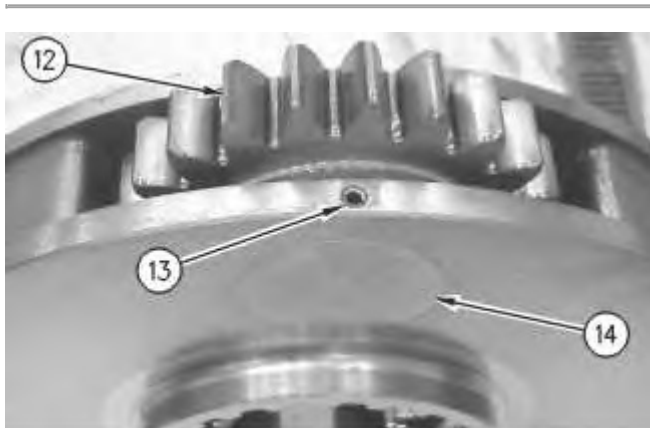

Illustration 8

g00865551

11. Drive spring pin (13) into shaft (14). Remove shaft (14) and gear assembly (12) .

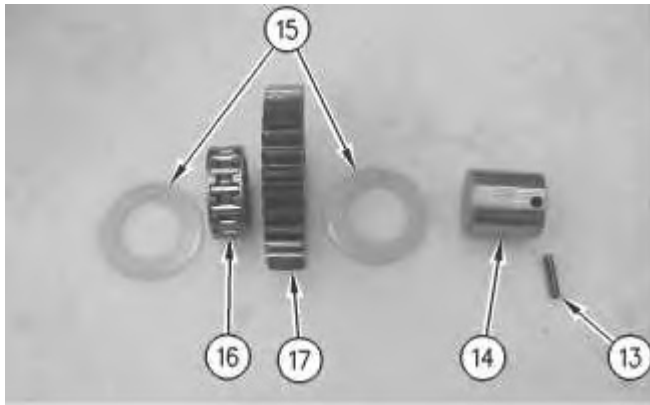

Illustration 9

g00865614

12. Remove washers (15) and bearing (16) from gear (17). Remove spring pin (13) from shaft (14) .
13. Repeat Steps 11 and 12 for the remaining gear assemblies.



Illustration 10

g00865671

14. Use Tooling (B) and a suitable lifting device to remove carrier assembly (18). The weight of carrier assembly (18) is approximately 68 kg (150 lb).
-

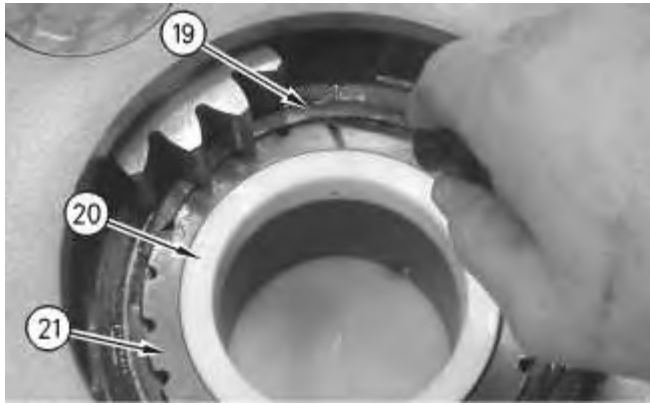

Illustration 11

g00865717

15. Remove retaining ring (19), spacer (20), and gear assembly (21) .

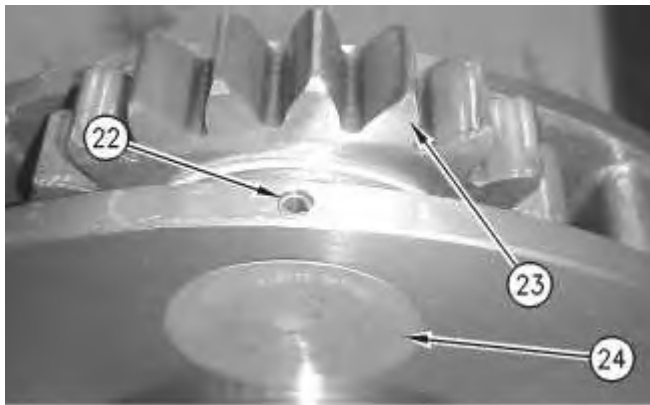

Illustration 12

g00865736

16. Drive spring pin (22) into planetary shaft (24). Remove planetary shaft (24) and gear assembly (23) .

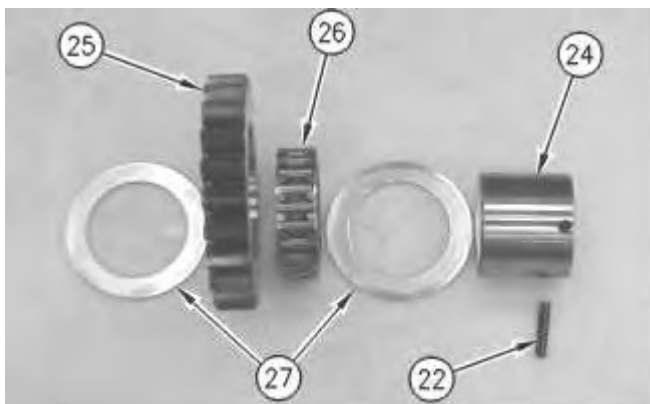

Illustration 13

g00865753

17. Remove thrust washers (27) and bearing (26) from planetary gear (25). Remove spring pin (22) from shaft (24) .
18. Repeat Steps 16 and 17 for the remaining gear assemblies.

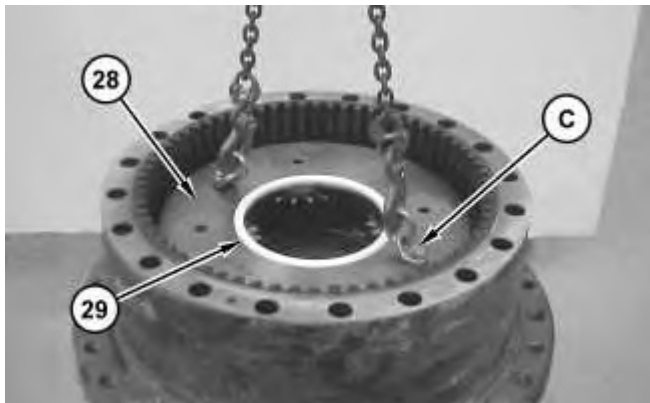

Illustration 14

g01192348

19. Use Tooling (C) and a suitable lifting device to remove carrier assembly (28). The weight of carrier assembly (28) is approximately 107 kg (235 lb).
20. Remove spacer (29) .

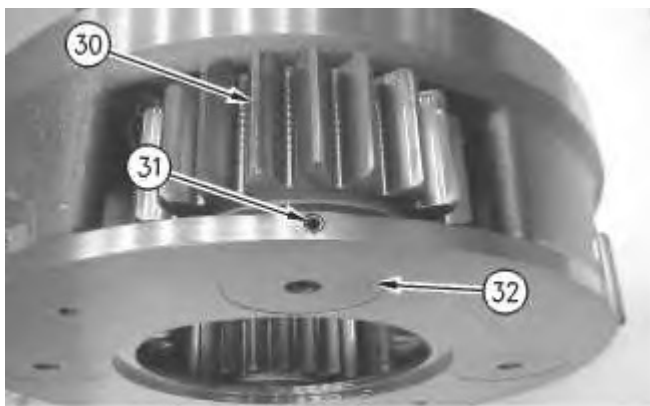

Illustration 15

g00865872

21. Drive spring pin (31) into shaft (32). Remove planetary shaft (32) and gear assembly (30) .
-

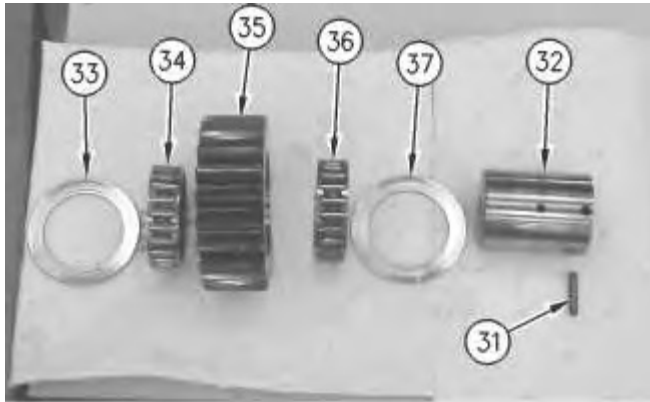

Illustration 16

g00865884

22. Remove thrust washers (33) and (37), and bearings (34) and (36) from planetary gear (35). Remove spring pin (31) from shaft (32) .
23. Repeat Steps 21 and 22 for the remaining gear assemblies.

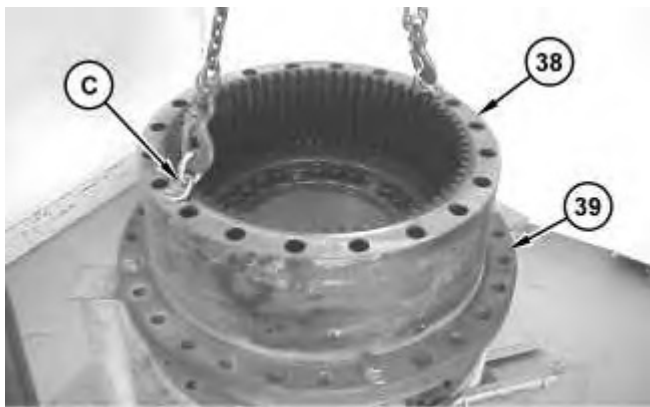

Illustration 17

g01192382

24. Use Tooling (C) and a suitable lifting device to remove ring gear (38) from housing (39). The weight of ring gear (38) is approximately 125 kg (275 lb).



25. Remove O-ring seal (40) from the main housing.



Illustration 19

26. Place suitable cribbing under the final drive in order to support the motor housing.

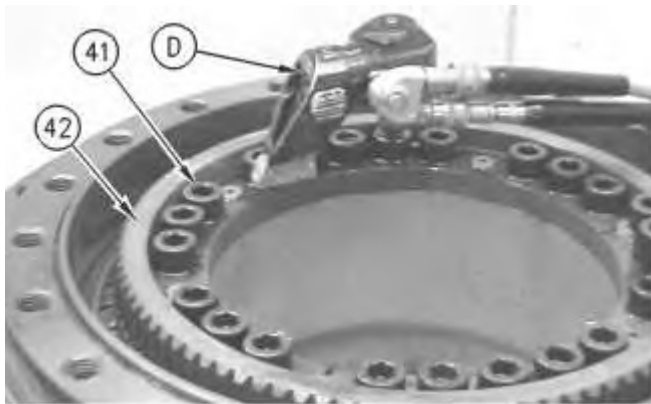

Illustration 20

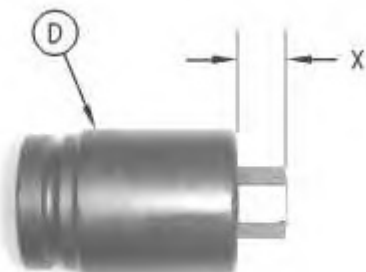

Illustration 21

g00865969

Dimension (X) is equal to 14.0 mm (0.55 inch).

27. Use Tooling (D) to remove bolts (41) from gear (42) .



Illustration 22

g00866066

28. Install Tooling (E) in the gear, as shown. Tighten Tooling (E) evenly in order to loosen the gear. Remove the gear from the motor housing.



Illustration 23

g00866072

29. Remove shims (43) from the motor housing.
-



Illustration 24

g00866085

30. Attach Tooling (C) and a suitable lifting device to main housing (45). The weight of main housing (45) is approximately 191 kg (420 lb).
31. Remove bolts (44) .
32. Use the suitable lifting device to separate main housing (45) from motor housing (39) .

Note: Motor housing (39) will rest on the suitable cribbing.



Illustration 25

g00866095

33. Remove bearing cone (46) from the main housing.

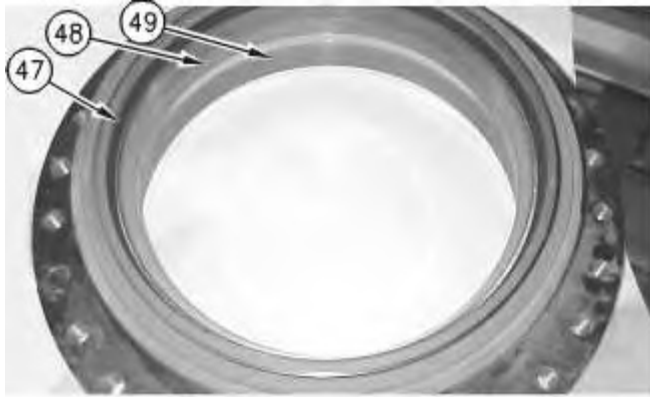

Illustration 26

g00866100

34. Remove Duo-Cone seal (47), and bearing cups (48) and (49) from the main housing.



Illustration 27

g00866156

35. Remove pins (50), if necessary.
36. Remove bearing cone (51) .
37. Remove Duo-Cone seal (52) from the motor housing.

[Previous Screen](#)

Product: EXCAVATOR

Model: 365C EXCAVATOR MCS

Configuration: 365C L Excavator MCS00001-UP (MACHINE) POWERED BY C-15 Engine

Disassembly and Assembly 365C Excavator Machine Systems

Media Number -REN8616-03

Publication Date -01/08/2012

Date Updated -24/08/2012

i07188314

Final Drive - Assemble

SMCS - 4050-016

Assembly Procedure

Table 1

Required Tools			
Tool	Part Number	Part Description	Qty
A	1P-2420	Transmission Repair Stand	1
B	439-3941	Link Bracket	3
C	439-3940	Link Bracket	2
D	385-7874	Hydraulic Torque Wrench	1
	385-8479	Hydraulic Pump and Motor Gp	1
	9U-7418	Hex Bit Socket	1
F	6V-3175	Double Acting Cylinder	1
	350-7768	Electric Hydraulic Pump Gp	1
	150-1784	Crossblock	1
	1U-9889	Crossblock	1
	150-1961	Washer	2
	150-1786	Plate	2
	4C-9634	Puller Stud	1
	9U-6832	Nut	1
	2K-7468	Locknut	1

	4K-0684	Locknut	2
	6V-2078	Stud	2
	5P-4807	Cap	2
H	140-7642	Duo-Cone Seal Installer As	1
J	-	Loctite	1
K	9S-3263	Thread Lock Compound	1
L	-	Loctite	1

1. Make sure that all parts of the final drive are thoroughly clean and free of dirt and debris prior to assembly.

Note: Check the condition of all the O-ring seals that are used in the final drive. If any of the seals are worn or damaged, use new parts for replacement.

2. Reassemble the final drive on wood blocks and Tooling (A).



Illustration 1

g00875656

3. Apply Tooling (J) to the surfaces that contact the bearing cones. Install the bearing cone with a press. Raise the temperature of bearing cone (51) and install the bearing cone.
4. Apply Tooling (J) to the surfaces that contact pins (50) and install contact pins (50).

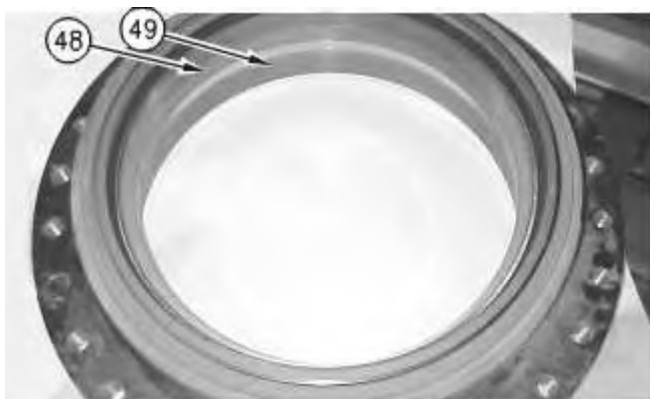

5. Apply Tooling (J) to the surfaces that contact the bearing cups. Install bearing cups (48) and (49).



Illustration 3

6. Attach Tooling (C) and a suitable lifting device to main housing (45). Install main housing (45) on motor housing (39). The weight of main housing (45) is approximately 191 kg (420 lb).



Illustration 4

7. Install bearing cone (46) and the bearing cone.
 8. Use the following procedure to determine the bearing preload and the correct number of shims.
-

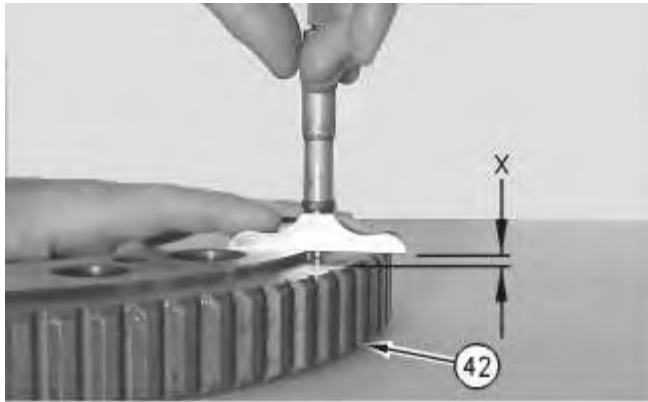

Illustration 5

g00603328

- a. Use a depth micrometer to measure the step length of the coupling gear (42). Take measurements at several different locations around the gear. Compute the average of the measured dimensions and record the number. Call this Dimension (X).

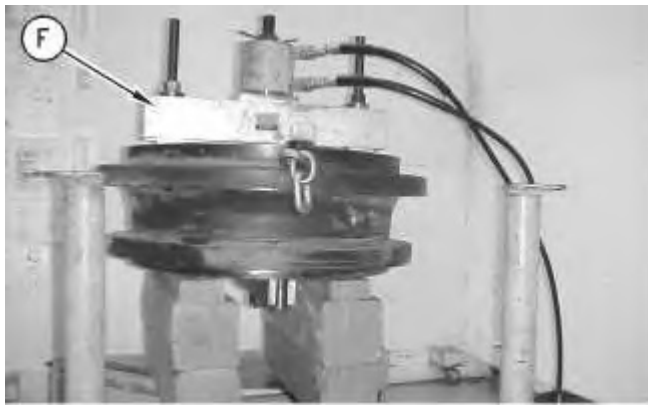

Illustration 6

g00876170

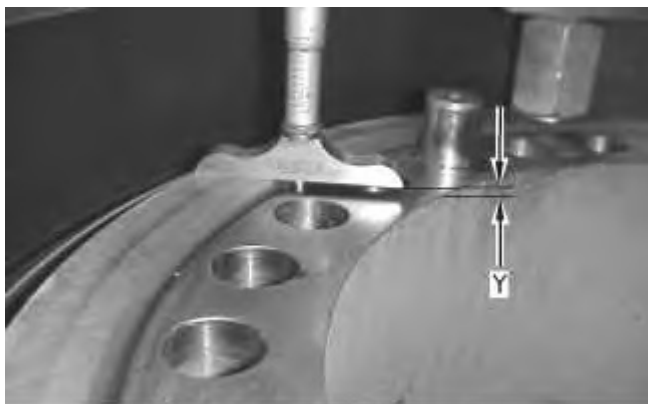

Illustration 7

g00876133

- b. Use Tooling (F) to apply a load of 10700 kPa (1550 psi) to seat the bearings. A pressure of 10700 kPa (1550 psi) is the equivalent of 10000 kg (22050 lb) on a suitable press. Rotate the housing to seat the bearing. Reduce the load to 4825 kPa (700 psi).

- c. Rotate Tooling (F) by 90° and repeat Step 8.b.
- d. Maintain the load on the bearings. Use a depth micrometer and measure the distance between the top face of motor housing and the bearing cone. Take this measurement in several locations around the bearing. Compute the average of the measured dimensions and record the number. Call this Dimension (Y).
- e. Determine the correct thickness of the shim pack that will be installed between the bearing cone and the coupling gear. The shim pack thickness is equal to Dimension (X) minus Dimension (Y). Tolerance for the shim pack is 0.10 mm (0.003 inch).

Note: If two shims are required, install the thinner shim next to the coupling gear when the coupling gear is installed.

9. Use Tooling (C) and a suitable lifting device to remove the main housing from the motor housing. The weight of the main housing is approximately 191 kg (420 lb).

Note: Refer to Disassembly and Assembly, "Duo-Cone Conventional Seals - Install"

Note: The rubber seals and all surfaces that contact the seals must be clean and dry. After installation of the seals, apply clean oil on the contact surfaces of the metal seals.



Illustration 8

g01192416

10. Use Tooling (H) to install Duo-Cone seal (47) in the main housing.



11. Use Tooling (H) to install Duo-Cone seal (52) in the motor housing.

Note: Make sure that the Duo-Cone seals are not scratched or damaged during the assembly of the main housing or during the assembly of the motor housing. After installation of the main housing on the motor housing, there will be a small gap between the components. The gap is caused by the Duo-Cone seals. The gap will be eliminated during installation of the gear.



Illustration 10

12. Use Tooling (C) and a suitable lifting device to position main housing (45) on motor housing (39). Make sure that the Duo-Cone seals are not scratched or damaged during installation. The weight of the main housing is approximately 191 kg (420 lb).



Illustration 11

13. Install bearing cone (46).
-



Illustration 12

g00866072



Illustration 13

g03671062

Typical Example

14. Place shims (43) in the correct position on the motor housing. If two shims were required, put the thinner shim in contact with coupling gear (42). Make sure that all the holes in the components are in alignment with each other. Put coupling gear (42) in the original position on the motor housing.
15. Apply Tooling (K) on the threads of bolts (41). Install the bolts to secure coupling gear (42) in place. Tighten bolts (41) evenly in a crisscross pattern to a torque of $1800 \pm 200 \text{ N}\cdot\text{m}$ ($1327 \pm 148 \text{ lb ft}$).



16. Install O-ring seal (40) in the main housing.



Illustration 15

g00866085

17. Use Tooling (C) and a suitable lifting device to position housings (39) and (45) on Tooling (A). The combined weight of housings (39) and (45) is approximately 363 kg (800 lb).
18. Install bolts (44) to secure the housings to Tooling (A).
19. Remove the suitable cribbing.

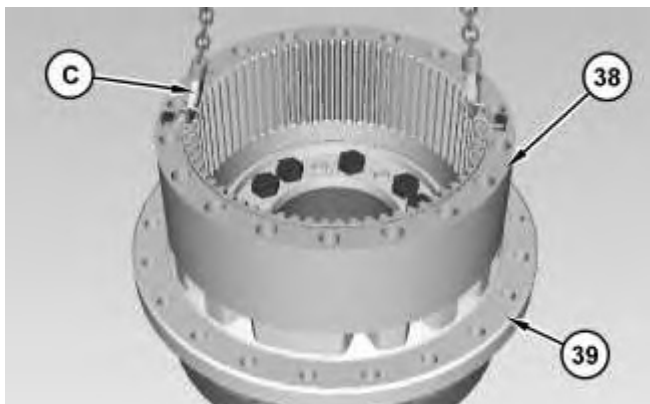

Illustration 16

g03671065

20. Thoroughly clean the mating surface of main housing (39) that contacts ring gear (38). Apply a bead of Tooling (L) on the mating surface of ring gear (38). Use Tooling (C) and a suitable lifting device to place ring gear (38) in position on main housing (39). Make sure that the alignment mark on main housing (39) and ring gear (38) line up with each other. It may be necessary to use a suitable hammer to seat ring gear (38) on main housing (39).
 21. Assemble the carrier assembly, as follows:
-

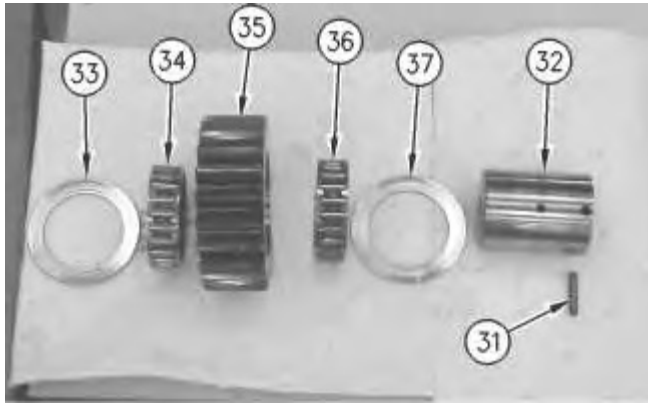

Illustration 17

g00865884

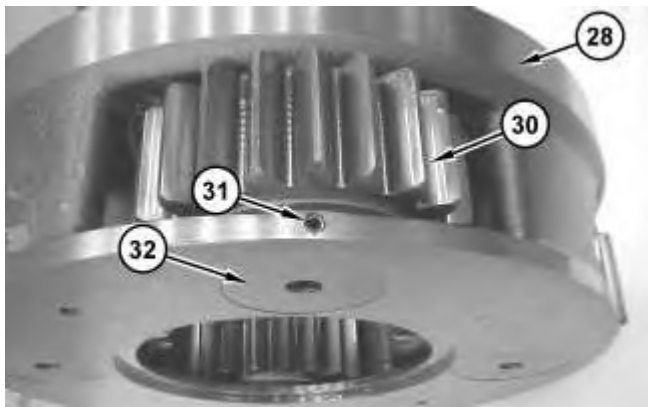

Illustration 18

g01192432

- a. Apply clean oil on bearings (34) and (36). Install bearings (34) and (36) in planetary gear (35).
 - b. Install thrust washers (33) and (37) on each side of planetary gear (35).
 - c. Install planetary gear (35) and thrust washers (33) in carrier assembly (28).
 - d. Install planetary shaft (32) in carrier assembly (28) and through planetary gear assembly (30). Make sure that the spring pin hole in planetary shaft (32) is in alignment with the spring pin hole in carrier assembly (28).
 - e. Install spring pin (31) in carrier assembly (28) and into planetary shaft (32). Make sure that the spring pin hole in planetary shaft (32) is in alignment with the spring pin hole in carrier assembly (28).
-

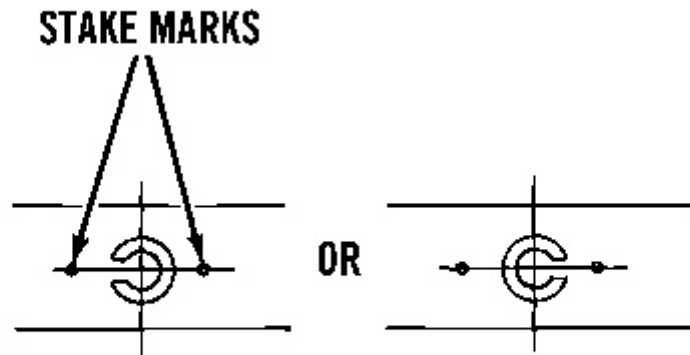

Illustration 19

g00513451

- f. Orient the split in spring pin (31) horizontally to the carrier. Align the split in the spring pin to the left or to the right. Make a stake mark on each side of the spring pin hole in the carrier. This will prevent the spring pin from falling out of the spring pin hole. Each stake mark should be approximately 1.5 to 3.00 mm (0.06 to 0.118 inch) from the outside diameter of the spring pin hole.
- g. Repeat Steps 21.a through 21.f to install the other three planetary gears in carrier assembly (28).

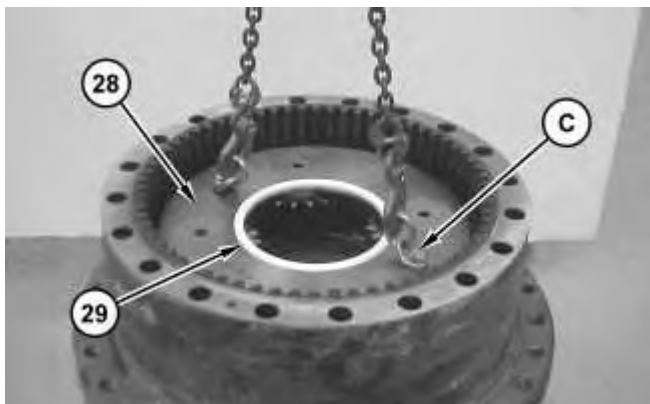

Illustration 20

g01192348

22. Use Tooling (C) and a suitable lifting device to install carrier assembly (28) in the ring gear. The weight of carrier assembly (28) is approximately 125 kg (275 lb).
23. Install spacer (29).
24. Assemble the carrier assembly, as follows:

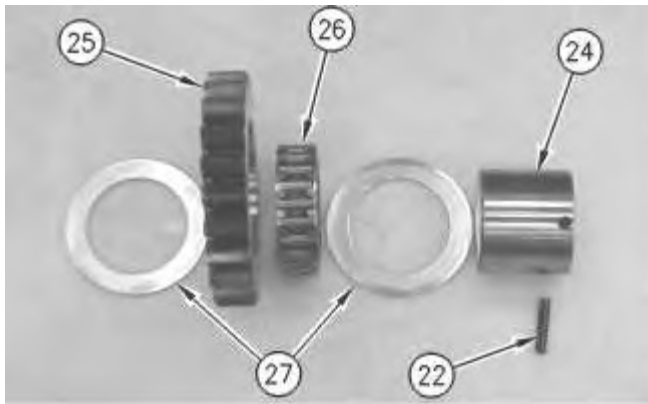

Illustration 21

g00865753

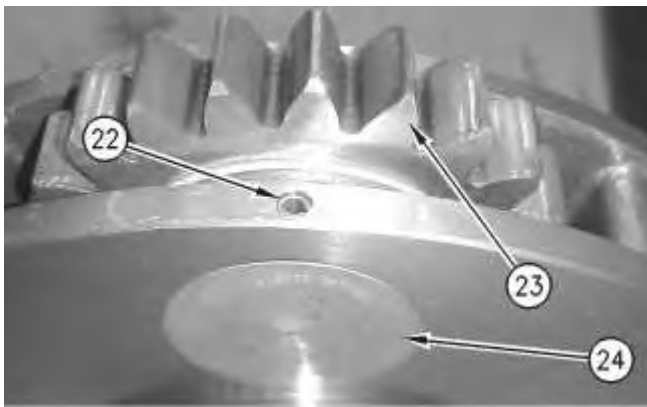

Illustration 22

g00865736

- a. Apply clean oil on bearing (26). Install bearing (26) in planetary gear (25).
- b. Install thrust washers (27) on each side of planetary gear (25).
- c. Install thrust washers (27) and planetary gear (25) in the carrier assembly.
- d. Install planetary shaft (24) in the carrier assembly and through planetary gear assembly (23). Make sure that the spring pin hole in planetary shaft (24) is in alignment with the spring pin hole in the carrier.

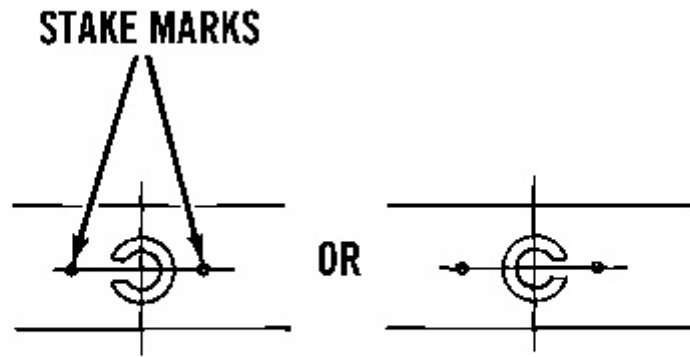

Illustration 23

g00513451

- e. Orient the split in the spring pin (22) horizontally to the carrier. Align the split in the spring pin to the left or to the right. Make a stake mark on each side of the spring pin hole in the carrier. This will prevent the spring pin from falling out of the spring pin hole. Each stake mark should be approximately 1.5 to 3.00 mm (0.06 to 0.118 inch) from the outside diameter of the spring pin hole.
- f. Repeat Steps 24.a through 24.e to install the other two planetary gears in the carrier assembly.

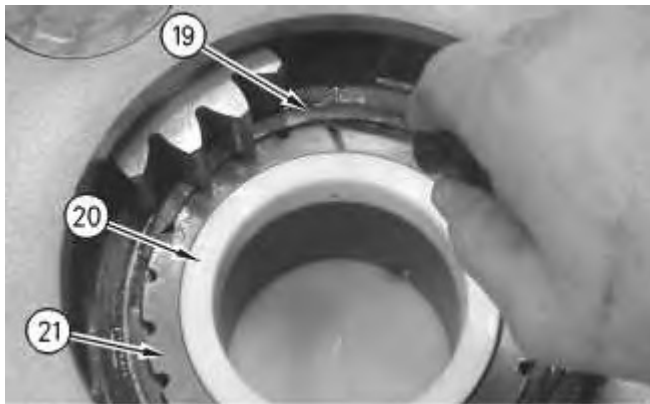

Illustration 24

g00865717

25. Install gear assembly (21), spacer (20), and retaining ring (19).



Suggest:

If the above button click is invalid.

Please download this document

first, and then click the above link

to download the complete manual.

Thank you so much for reading



Illustration 25

g00865671

26. Use Tooling (B) and a suitable lifting device to install carrier assembly (18). The weight of carrier assembly (18) is approximately 68 kg (150 lb).

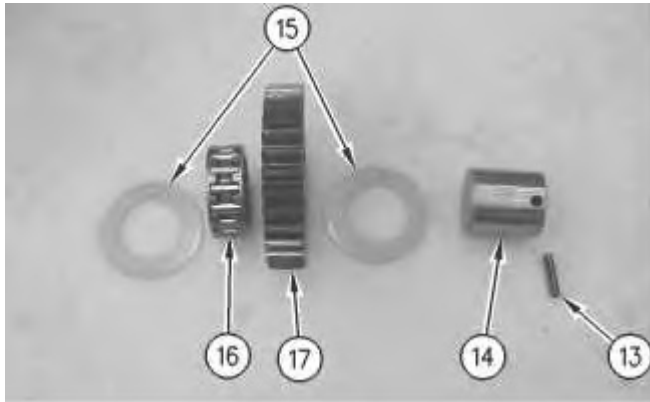

Illustration 26

g00865614

27. Apply clean oil on bearing (16). Install washers (15) and bearing (16) in gear (17).

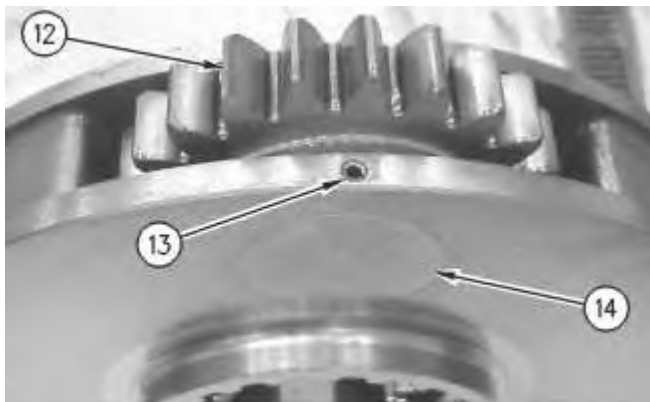

Illustration 27

g00865551

28. Install gear assembly (12) and shaft (14). Drive spring pin (13) into shaft (14).
29. Repeat Steps 27 and 28 for the remaining gear assemblies.

<https://www.ebooklibonline.com>

Hello dear friend!

Thank you very much for reading.

Enter the link into your browser.

The full manual is available for immediate download.

<https://www.ebooklibonline.com>