



Service Repair Manual

Models

345C L Excavator

[Previous Screen](#)

Product: EXCAVATOR

Model: 345C L EXCAVATOR FPC

Configuration: 345C L Hydraulic Excavator FPC00001-UP (MACHINE) POWERED BY C13 Engine

Disassembly and Assembly

345C Excavator and 345C MHPU

Mobile Hydraulic Power Unit Machine Systems

Media Number -REN8612-06

Publication Date -01/02/2013

Date Updated -21/02/2013

i05331566

Final Drive - Disassemble

SMCS - 4050-015

Disassembly Procedure

Table 1

| Required Tools | | | |
|----------------|-------------|--------------------------|-----|
| Tool | Part Number | Part Description | Qty |
| A | 1P-2420 | Transmission Stand Group | 1 |
| B | 138-7573 | Link Bracket | 2 |
| C | 1P-1860 | Retaining Ring Pliers | 1 |
| D | 4C-8359 | Eyebolt | 3 |
| E | 4C-8359 | Eyebolt | 2 |
| F | 138-7574 | Link Bracket | 2 |

Start By:

- A. Remove the final drive. Refer to Disassembly and Assembly, "Final Drive and Travel Motor - Remove" in this manual.
 1. Thoroughly clean the outside of the final drive and travel motor prior to disassembly.
-

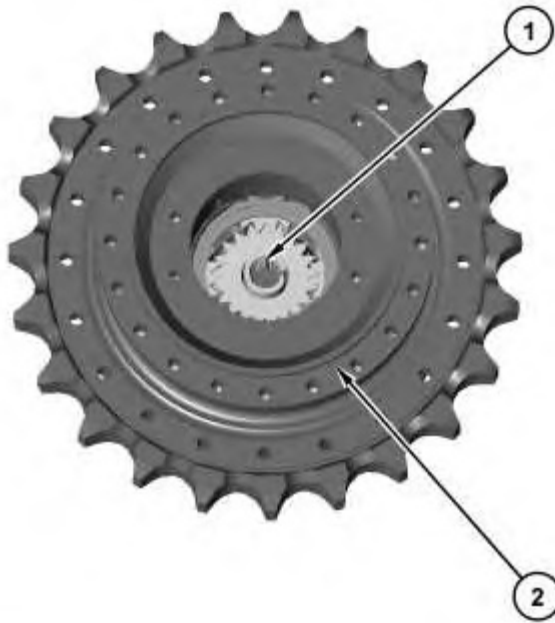

Illustration 1

g01207795

2. Remove coupling (1) from final drive (2) .
3. Attach a suitable lifting device to the final drive, and turn final drive (2) over 180 degrees. The weight of final drive (2) is approximately 590 kg (1300 lb).

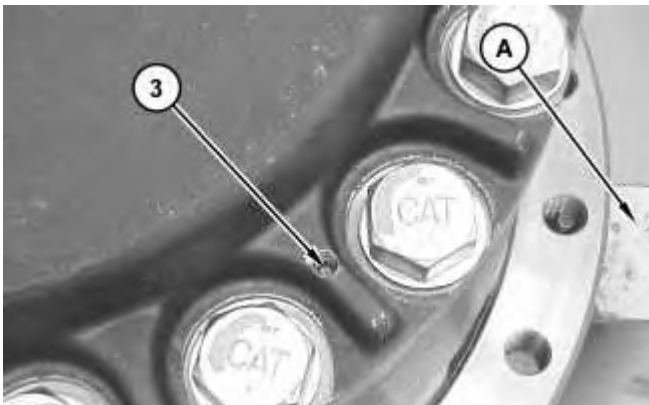

Illustration 2

g01207796

4. Attach the final drive to Tooling (A) . Put an alignment mark across the sections of the final drive for assembly purposes. All parts must be reinstalled in the original locations.
5. Remove socket head screws (3) from the final drive cover.

<https://www.ebooklibonline.com>

Hello dear friend!

Thank you very much for reading.

Enter the link into your browser.

The full manual is available for immediate download.

<https://www.ebooklibonline.com>



Illustration 3

g01207801

6. Attach Tooling (B) and a suitable lifting device to cover (5) , as shown. The weight of cover (5) is approximately 52 kg (115 lb).
7. Remove bolts (4) and the washers that hold the cover in place.
8. Use a soft faced hammer in order to break the seal between cover (5) and the ring gear. Remove cover (5) . The weight of cover (5) is 52 kg (115 lb).

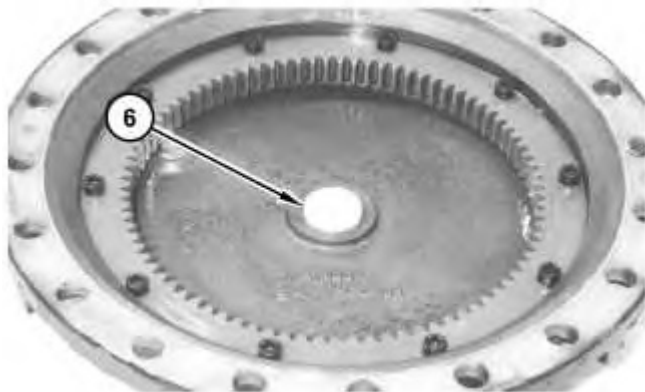

Illustration 4

g01207835

9. Remove spacer (6) from the cover.
-



Illustration 5

g01207845

10. Remove shims (7) from the cover.
11. Remove socket head bolts (8) and ring gear (9) from the cover.



Illustration 6

g01207864

12. Remove sun gear (10) from carrier assembly (11) . Remove carrier assembly (11) by lifting the carrier assembly straight up.
13. Disassemble carrier assembly (11) , as follows:

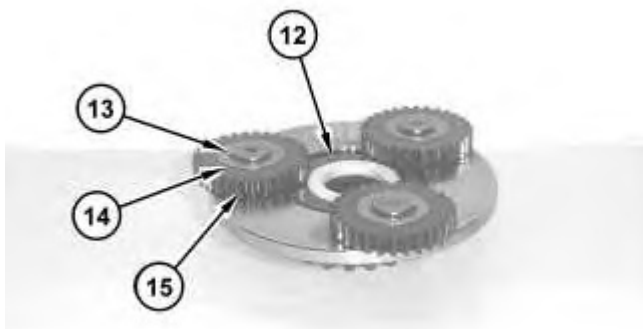

- a. Remove spacers (12) . A spacer is located on each side of the sun gear in carrier assembly (11) .

Note: Planetary gears (15) might be stamped with identification marks "L". Note the position of the identification marks in relation to the carrier for assembly purposes.

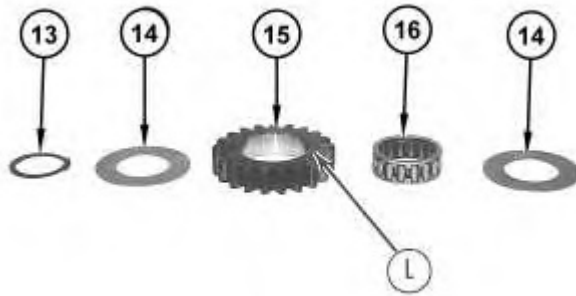

- b. Remove retaining ring (13) with Tooling (C) .
- c. Remove thrust washers (14) and planetary gear (15) from the carrier.
- d. Remove bearing (16) from the planetary gear.
- e. Repeat Steps 13.b through 13.d for the other two planetary gears.



- f. Use a screwdriver in order to remove retaining ring (17) from the carrier. Remove sun gear (18) from the carrier.



Illustration 10

g01208136

14. Attach Tooling (D) and a suitable lifting device to carrier assembly (19) , as shown. Remove carrier assembly (19) by pulling the carrier assembly straight up. The weight of carrier assembly (19) is approximately 45 kg (100 lb).
15. Disassemble carrier assembly (19) , as follows:

Note: Spacer (20) may remain with carrier assembly (19) , or the spacer may remain with carrier assembly (28) . Refer to Step 17.



Illustration 11

g01208162

- a. Remove spacer (20) from carrier assembly (19) .
-

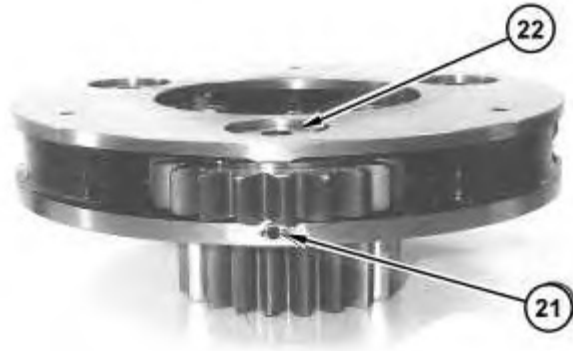

Illustration 12

g01208169

- b. Drive spring pin (21) into planetary shaft (22) with a hammer and a punch.

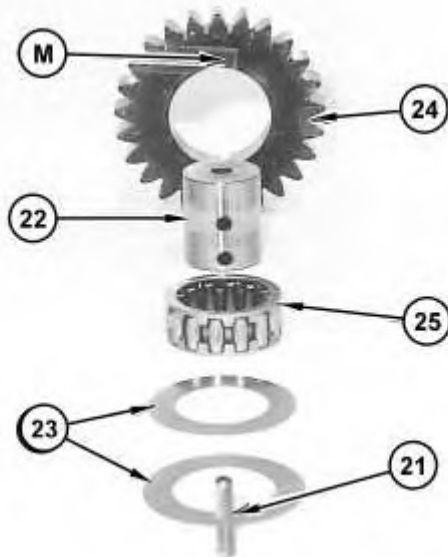

Illustration 13

g01208189

- c. Remove planetary shaft (22) , two thrust washers (23) and planetary gear (24) from the carrier.

Note: Planetary gears (24) might be stamped with identification marks "M". Note the position of the identification marks in relation to the carrier for assembly purposes.

- d. Remove bearing (25) from the planetary gear.
- e. Remove spring pin (21) from planetary shaft (22) with a hammer and a punch.
- f. Repeat Steps 15.b through 15.e in order to remove the other two planetary gears from the carrier.
-



Illustration 14

g01208245

- g. Use a screwdriver to remove retaining ring (26) . Remove sun gear (27) from the carrier.

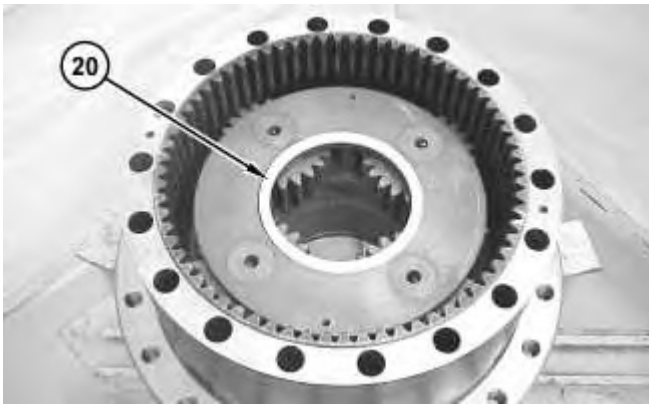

Illustration 15

g01208253

16. If spacer (20) was not removed in Step 15.a, remove the spacer from carrier assembly (28) at this time.

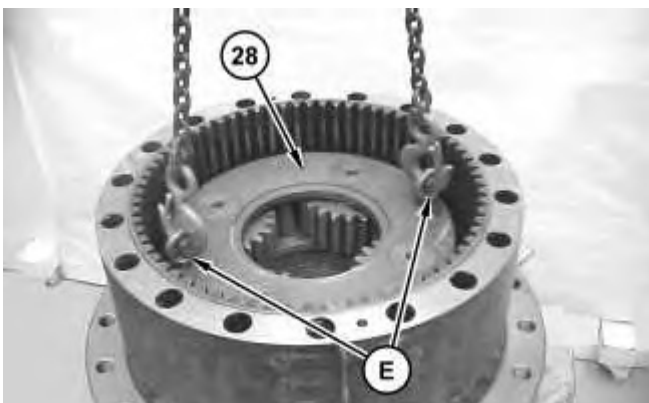

Illustration 16

g01208256

17. Attach Tooling (E) and a suitable lifting device to carrier assembly (28) , as shown. Remove carrier assembly (28) . The weight of carrier assembly (28) is approximately 64 kg (140 lb).
18. Disassemble carrier assembly (28) , as follows:

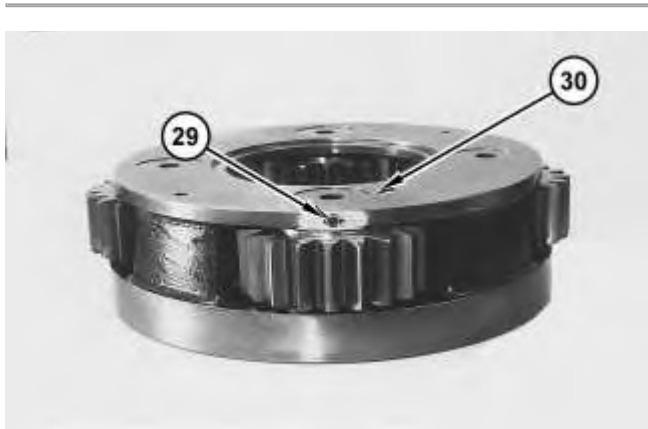

Illustration 17

g01208265

- a. Drive spring pin (29) into planetary shaft (30) with a hammer and a punch.

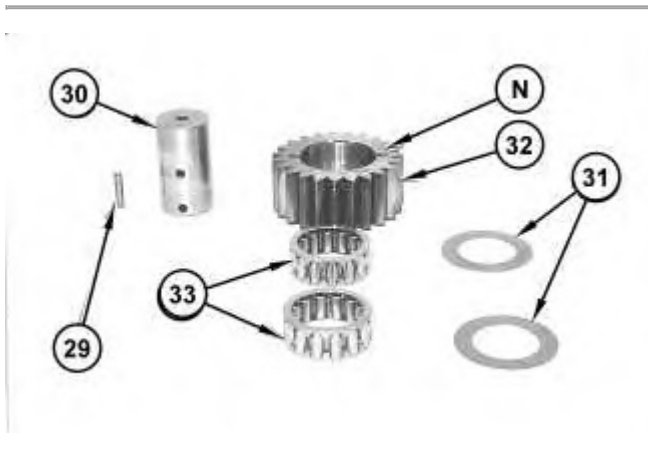

Illustration 18

g01208280

- b. Remove planetary shaft (30) , two thrust washers (31) , and planetary gear (32) from the carrier.

Note: Planetary gears (32) might be stamped with identification marks "N". Note the position of the identification marks in relation to the carrier for assembly purposes.

- c. Remove bearings (33) from the planetary gear.
- d. Drive spring pin (29) out of planetary shaft (30) with a hammer and a punch.
- e. Repeat Steps 18.a through 18.d in order to remove the other three planetary gears from the carrier.



Illustration 19

g01208300

19. Fasten Tooling (E) and a suitable lifting device to ring gear (34) , as shown. Remove ring gear (34) from sprocket housing (35) . The weight of ring gear (34) is approximately 82 kg (180 lb).



Illustration 20

g01208542

20. Remove O-ring seal (36) from sprocket housing (35) .

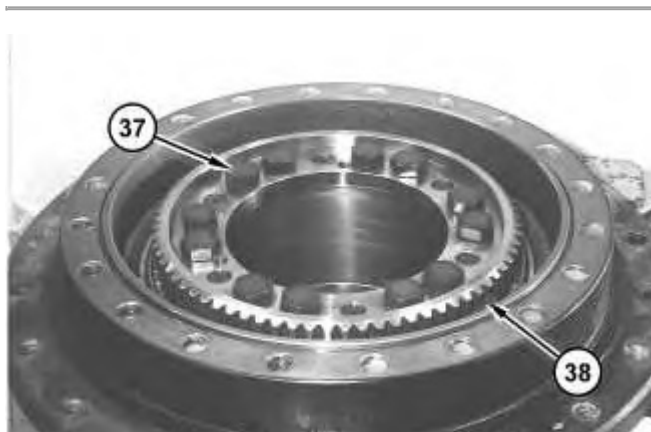

Note: Mark the orientation of coupling (38) for assembly purposes.

21. Remove bolts (37) from coupling gear (38) .

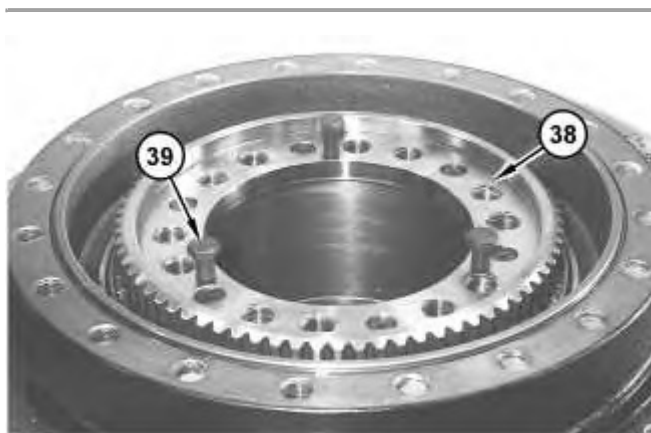

Illustration 22

22. Install suitable forcing bolts (39) in coupling gear (38) , as shown. Tighten the forcing bolts evenly in order to loosen coupling gear (38) . Remove the coupling gear from the motor housing.



Illustration 23



Illustration 24

g01208625

23. Remove shims (40) from the motor housing.

Note: Inner cones and outer bearing cones (42) are a slip fit on the motor housing. While you remove sprocket housing (35) from the motor housing, inner bearing cone (42) may stay with the sprocket housing or the inner bearing cone may stay on the motor housing.

24. Fasten Tooling (F) and a suitable lifting device to sprocket housing (35), as shown. Separate the sprocket housing from the motor housing. The weight of sprocket housing (35) is 127 kg (280 lb).



Illustration 25

g01208626

25. Remove the locating pins from the motor housing.
26. Remove duo-cone seal gp (41) from the motor housing.
27. If inner bearing cone (42) remained on the motor housing, then remove the inner bearing cone.
-



Illustration 26

g01208633

28. Remove duo-cone seal gp (43) from the sprocket housing.
29. If inner bearing cone (42) remained on the sprocket housing, then remove the inner bearing cone.
30. Remove the bearing cups from the sprocket housing.

[Previous Screen](#)

Product: EXCAVATOR

Model: 345C L EXCAVATOR FPC

Configuration: 345C L Hydraulic Excavator FPC00001-UP (MACHINE) POWERED BY C13 Engine

Disassembly and Assembly

345C Excavator and 345C MHPU

Mobile Hydraulic Power Unit Machine Systems

Media Number -REN8612-06

Publication Date -01/02/2013

Date Updated -21/02/2013

i05970668

Final Drive - Assemble

SMCS - 4050-016

Assembly Procedure

Table 1

| Required Tools | | | |
|----------------|-------------|----------------------------|-----|
| Tool | Part Number | Part Description | Qty |
| A | 1P-2420 | Transmission Repair Stand | 1 |
| B | 138-7573 | Link Bracket | 2 |
| C | 1P-1860 | Retaining Ring Pliers | 1 |
| D | 4C-8359 | Eyebolt | 3 |
| E | 4C-8359 | Eyebolt | 2 |
| F | 138-7574 | Link Bracket | 2 |
| G | 8T-0531 | Duo-Cone Seal Installer As | 1 |
| H | 4C-5599 | Anti-Seize Compound | 1 |
| J | 9S-3263 | Thread Lock Compound | 1 |
| K | 1U-8846 | Gasket Sealant | 1 |
| L | 6V-7059 | Micrometer | 1 |
| M | 1U-9895 | Crossblock | 1 |

1. Make sure that all parts of the final drive are thoroughly clean and free of dirt and debris prior to assembly. Check the condition of all O-ring seals that are used in the final drive. If

any of the seals are damaged, use new parts for replacement. Reassemble the final drive on Tooling (A) .



Illustration 1

g01208879

2. Apply Tooling (H) to the surfaces inside sprocket housing (35) that makes contact with the bearing cups. Install a bearing cup that is in each side of the sprocket housing with a press. Make sure that the bearing cups are properly seated.
3. Apply Tooling (H) to the surfaces inside the motor housing that makes contact with bearing cones (42) .
4. Install inner bearing cone (42) on the motor housing.



Illustration 2

g01208625

5. Apply Tooling (F) and a suitable lifting device to sprocket housing (35) , as shown. The weight of sprocket housing (35) is approximately 127 kg (280 lb). Install sprocket housing (35) on the motor housing. Carefully install outer bearing cone (42) on the sprocket housing.
-



Illustration 3

g01208578

6. Adjust the bearing preload of the final drive. Determine the correct number of shims (40) that are required for the proper bearing preload, as follows:

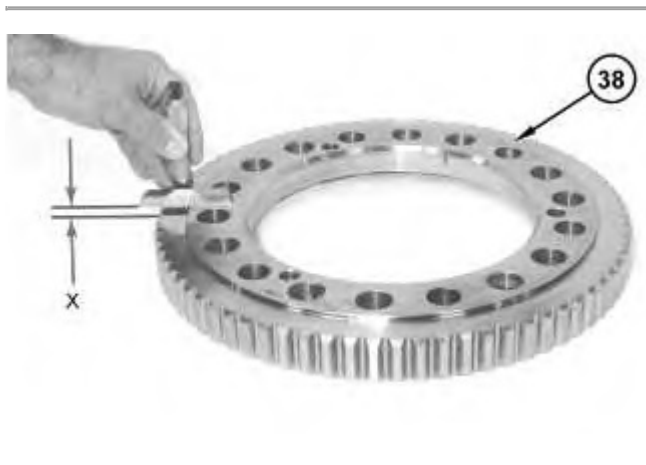

Illustration 4

g01208987

- a. Use a depth micrometer in order to measure the step height of coupling gear (38) at several locations around the gear. Find the average for the measured dimensions around the gear and record the dimension. Call this Dimension (X) .
- b. Apply a load of 10000 kg (22000 lb) to bearing cones (42) .
- c. Rotate sprocket housing (35) several times in order to seat the bearing cones.
- d. Reduce the load to 3500 ± 350 kg (7700 ± 770 lb).



Illustration 5

g00631001

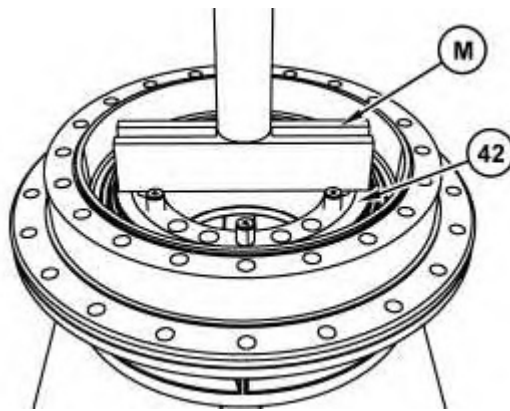

Illustration 6

g03742848

- e. While the load is still on the bearing cones, measure the distance between the top face of the motor housing and the top face of bearing cone (42) . Take measurements in several locations around the motor housing. Find the average of the measured dimensions, and record the dimensions. Call this Dimension (Y) .
- f. Determine the correct thickness of shims (40) which are used between bearing cone (42) and coupling gear (38) . Use the following equation in order to determine the shim pack thickness.

Shim pack thickness ... $(X) - (Y) \pm 0.05 \text{ mm (0.002 inch)}$

Note: If shims (40) are required, install the thinnest shim next to coupling gear (38) during final assembly.



Illustration 7

g01208625

7. Apply Tooling (F) and a suitable lifting device to sprocket housing (35) , as shown. Separate sprocket housing (35) from the motor housing.

Reference Refer to Disassembly and Assembly, "Duo-Cone Conventional Seals - Install".

Note: The rubber seals and all surfaces that makes contact with the seals must be clean and dry. After installation of the seals, put clean SAE 30 oil on the contact surfaces of the metal seals.



Illustration 8

g00631006



8. Install Duo-Cone seal kit (43) in the sprocket housing with Tooling (G) .



Illustration 10



Illustration 11



Illustration 12

9. Install Duo-Cone seal kit (41) in the motor housing with Tooling (G) .
10. Apply Tooling (H) in the bores for the locating pins that are in the motor housing. Reinstall the locating pins in the motor housing.
11. Make sure that inner bearing cone (42) is seated properly on the motor housing.

Note: Do not scratch Duo-Cone seal gp (41) or damage the Duo-Cone seal gp in the main housing, or the motor housing during assembly of the two components. After installation of the main housing on the motor housing, there will be a small gap between the components. The gap between the components is caused by the Duo-Cone seal kit. This will be eliminated during the installation of the coupling gear.

12. Attach Tooling (F) and a suitable lifting device to sprocket housing (35) , as shown. Carefully install the sprocket housing on the motor housing.
13. Install outer bearing cone (42) on the sprocket housing. Make sure that the outer bearing cone is properly seated.



Illustration 13

g01208578

14. Install shims (40) that were determined in Steps 6.a through 6.f on the end of the sprocket housing, as shown. If shims were required, make sure that the thinnest shim is installed on top.

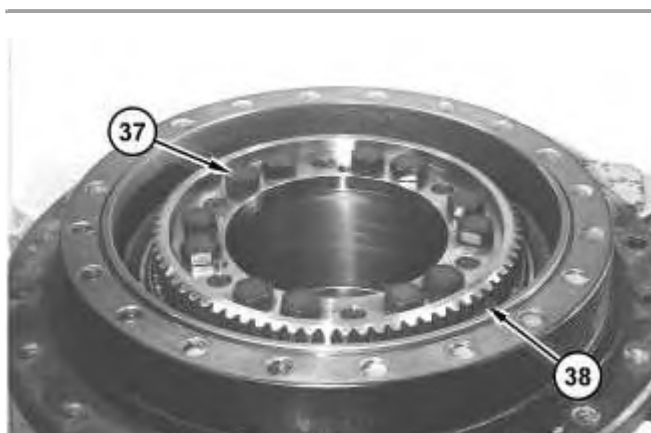

15. Put coupling gear (38) in the original position on the motor housing.
16. Apply Tooling (J) on the threads of bolts (37) that hold coupling gear (38) in position. Tighten bolts (37) evenly and tighten the bolts in diagonally opposite pairs.

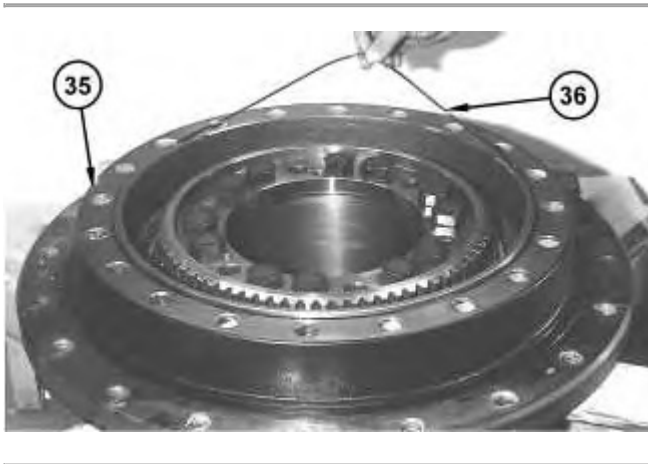

Illustration 15

17. Install O-ring seal (36) in sprocket housing (35) .



Illustration 16

18. Thoroughly clean the mating surface of sprocket housing (35) that will make contact with ring gear (34) .
19. Apply a bead of Tooling (K) on the mating surface of ring gear (34) .
20. Attach Tooling (E) and a suitable lifting device to ring gear (34) . Put ring gear (34) in position on the sprocket housing. The weight of ring gear (34) is approximately 82 kg (180 lb). Make sure that the alignment mark up on the sprocket housing and the ring gear line with each other.

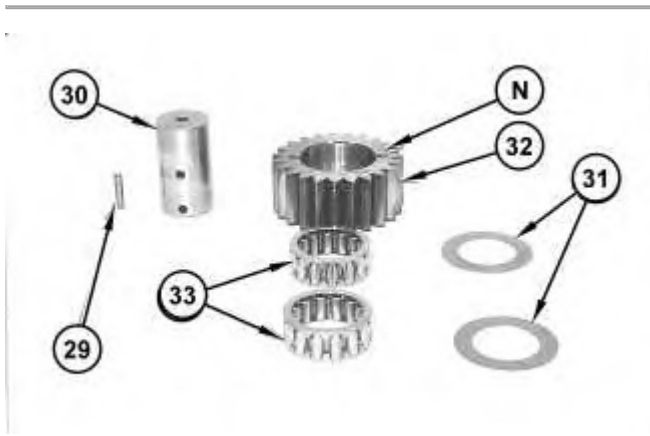

Illustration 17

g01208280

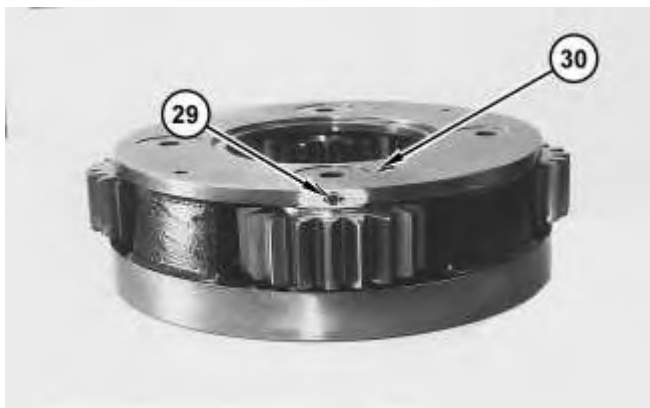
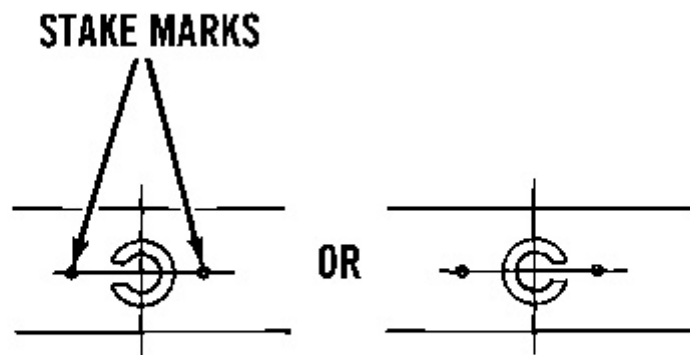

Illustration 18

g01208265



21. Assemble carrier assembly (28) , as follows:

Note: If planetary gear (32) is stamped with an "N", make sure that the planetary gear identification grooves are facing in the correct direction, which was noted during the disassembly of the carrier assembly (28) .

- a. Assemble carrier assembly (28) .
- b. Put clean SAE 30 oil on bearings (33) .
- c. Install bearings (33) in planetary gear (32) .
- d. Install a thrust washer (31) on each side of the planetary gear.
- e. Install the planetary gear and thrust washers in carrier (28) .
- f. Install planetary shaft (30) in carrier (28) and through planetary gear (32) . Make sure that the spring pin hole in the planetary shaft is in alignment with the spring pin hole in the carrier.
- g. Install spring pin (29) in the carrier and into the planetary shaft. Install the spring pin until the spring pin is even with the outside surface of the carrier. Orient the split in the spring pin horizontally to the carrier. Align the split in the spring pin to the left or to the right. Refer to Illustration 19.
- h. Make a stake mark on each side of the spring pin hole in the carrier. This will prevent the spring pin from falling out of the spring pin hole. Each stake mark should be approximately 1.5 to 3.00 mm (.59 to .118 inch) from the spring pin hole.
- i. Repeat Steps 21.a through 21.h in order to install the remaining three planetary gears in carrier (30) .

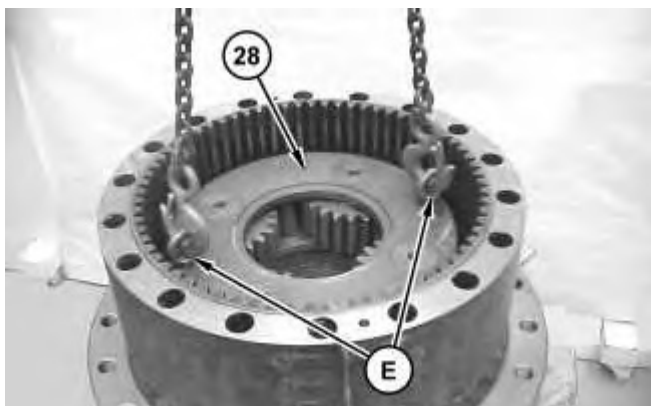

Illustration 20

g01208256

22. Attach Tooling (E) and a suitable lifting device to carrier assembly (28) . The weight of carrier assembly (28) is approximately 64 kg (140 lb). Put carrier assembly (28) in position

in the ring gear. It will be necessary to rotate carrier assembly (28) back and forth during installation in order to engage all the gears properly.



Illustration 21

g01208253

23. Install spacer (20) on carrier assembly (28) .
24. Assemble carrier assembly (19) , as follows:



Illustration 22

g01208245



Suggest:

If the above button click is invalid.

Please download this document

first, and then click the above link

to download the complete manual.

Thank you so much for reading

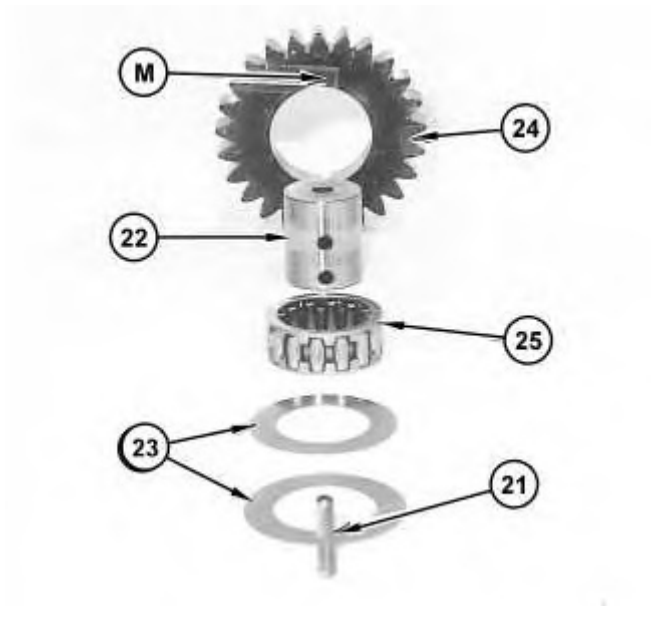

Illustration 23

g01208189

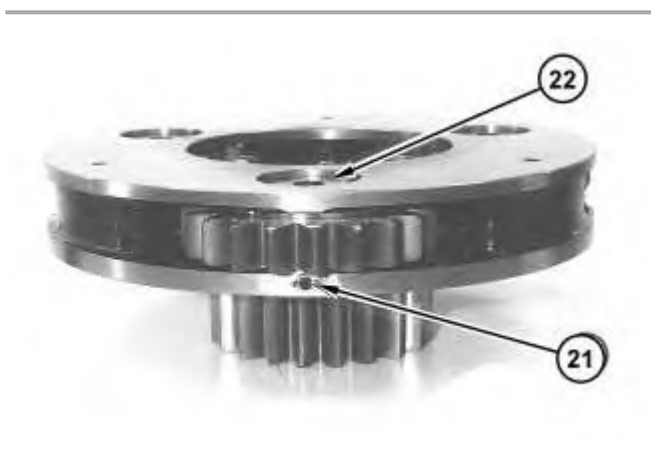

Illustration 24

g01208169

<https://www.ebooklibonline.com>

Hello dear friend!

Thank you very much for reading.

Enter the link into your browser.

The full manual is available for immediate download.

<https://www.ebooklibonline.com>