



# Service Repair Manual

## **Models**

# 345B Series II Excavator

---

[Previous Screen](#)

Product: EXCAVATOR

Model: 345B II EXCAVATOR CCC

Configuration: 345B Series II Excavator CCC00001-UP (MACHINE) POWERED BY 3176C Engine

## Disassembly and Assembly 3176C and 3196 Engines for Caterpillar Built Machines

Media Number -REN1223-15

Publication Date -01/08/2015

Date Updated -03/08/2015

i01604601

# Rocker Shaft and Pushrod - Remove

SMCS - 1102-011; 1208-011

## Removal Procedure

### Start By:

- A. Remove the valve mechanism cover. Refer to Disassembly and Assembly, "Valve Mechanism Cover - Remove and Install".

---

### NOTICE

**Keep all parts clean from contaminants.**

**Contaminants may cause rapid wear and shortened component life.**

---

---

### NOTICE

**Care must be taken to ensure that fluids are contained during performance of inspection, maintenance, testing, adjusting and repair of the product. Be prepared to collect the fluid with suitable containers before opening any compartment or disassembling any component containing fluids.**

**Refer to Special Publication, NENG2500, "Caterpillar Tools and Shop Products Guide" for tools and supplies suitable to collect and contain fluids on Caterpillar products.**

**Dispose of all fluids according to local regulations and mandates.**

---

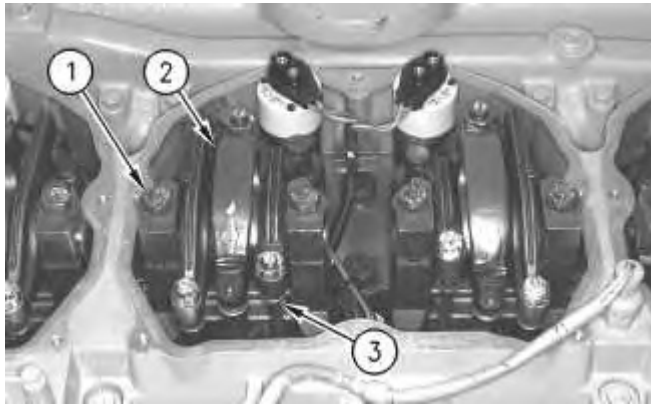

Illustration 1

g00515542

1. Place an identification mark on each rocker arm in order to identify the proper location in the engine for installation.
2. Remove bolts (1) and rocker arms (2) .
3. Remove push rods (3). Keep each push rod with the respective rocker arm.



Illustration 2

g00515374

4. Remove valve bridges (4) .

**<https://www.ebooklibonline.com>**

Hello dear friend!

Thank you very much for reading.

Enter the link into your browser.

The full manual is available for immediate download.

**<https://www.ebooklibonline.com>**

[Previous Screen](#)

Product: EXCAVATOR

Model: 345B II EXCAVATOR CCC

Configuration: 345B Series II Excavator CCC00001-UP (MACHINE) POWERED BY 3176C Engine

## Disassembly and Assembly 3176C and 3196 Engines for Caterpillar Built Machines

Media Number -REN1223-15

Publication Date -01/08/2015

Date Updated -03/08/2015

i07141366

# Rocker Shaft and Pushrod - Install

SMCS - 1102-012; 1208-012

## Installation Procedure

---

### NOTICE

**Keep all parts clean from contaminants.**

**Contaminants may cause rapid wear and shortened component life.**

---

1. Inspect the condition of the following items: rocker arms, valve bridges, and push rods. Replace the parts, if necessary.

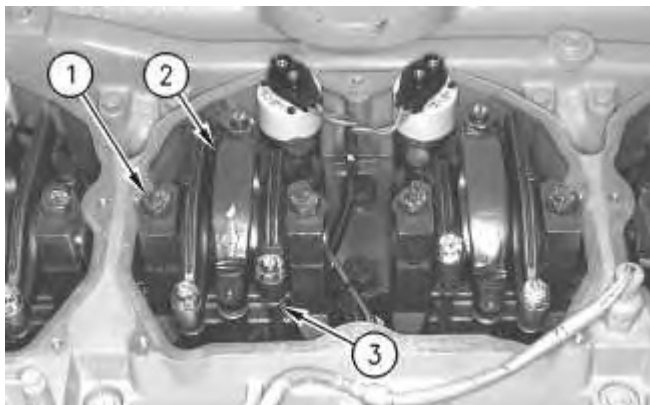

Illustration 1

g00515542

2. Install push rods (3) in the correct location in the engine.
-



Illustration 2

g00515374

3. Install valve bridges (4). Lubricate the top surface of the valve bridges with clean engine oil.
4. Place rocker arms (2) in the correct locations that were marked during removal. Install bolts (1) and tighten to a torque of  $100 \pm 20$  N·m ( $74 \pm 15$  lb ft).

**End By:**

- a. Install the valve mechanism cover. Refer to Disassembly and Assembly, "Valve Mechanism Cover - Remove and Install".

Previous Screen

Product: EXCAVATOR

Model: 345B II EXCAVATOR CCC

Configuration: 345B Series II Excavator CCC00001-UP (MACHINE) POWERED BY 3176C Engine

**Disassembly and Assembly  
3176C and 3196 Engines for Caterpillar Built Machines**

Media Number -REN1223-15

Publication Date -01/08/2015

Date Updated -03/08/2015

i01771996

## Cylinder Head - Remove

SMCS - 1100-011

### Removal Procedure

Table 1

| Required Tools |             |                       |     |
|----------------|-------------|-----------------------|-----|
| Tool           | Part Number | Part Description      | Qty |
| A              | 185-3630    | Strap Wrench Assembly | 1   |

**Start By:**

- A. Remove the base for the valve mechanism cover. Refer to Disassembly and Assembly, "Valve Mechanism Cover Base - Remove and Install".
- B. Remove the rocker shaft and the pushrods. Refer to Disassembly and Assembly, "Rocker Shaft and Pushrod - Remove".

---

**NOTICE**

**Keep all parts clean from contaminants.**

**Contaminants may cause rapid wear and shortened component life.**

---

**NOTICE**

**Care must be taken to ensure that fluids are contained during performance of inspection, maintenance, testing, adjusting and repair of the product. Be prepared to collect the fluid with suitable containers**

**before opening any compartment or disassembling any component containing fluids.**

**Refer to Special Publication, NENG2500, "Caterpillar Tools and Shop Products Guide" for tools and supplies suitable to collect and contain fluids on Caterpillar products.**

**Dispose of all fluids according to local regulations and mandates.**

---

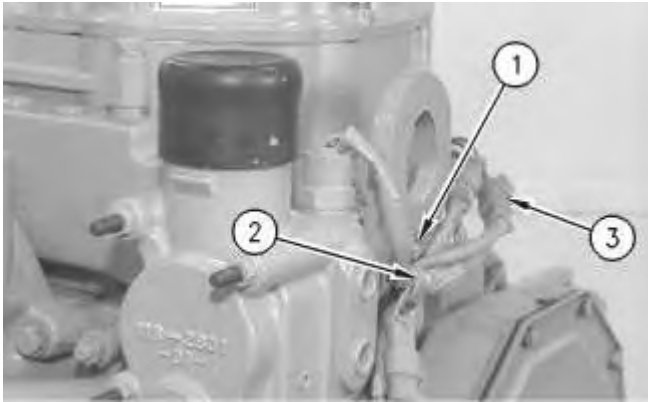

Illustration 1

g00517348

1. Remove bolt (1). Remove clip (2) .
2. Disconnect sensors from engine wiring harness (3) .
3. Remove the sensors.

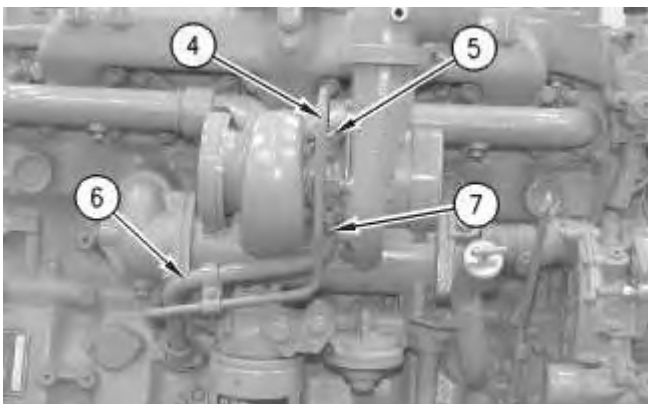

Illustration 2

g00517351

4. Remove bolts (5). Disconnect tube assembly (4) and remove the O-ring seal.
5. Remove bolts (7). Disconnect tube assembly (6) and remove the O-ring seals.

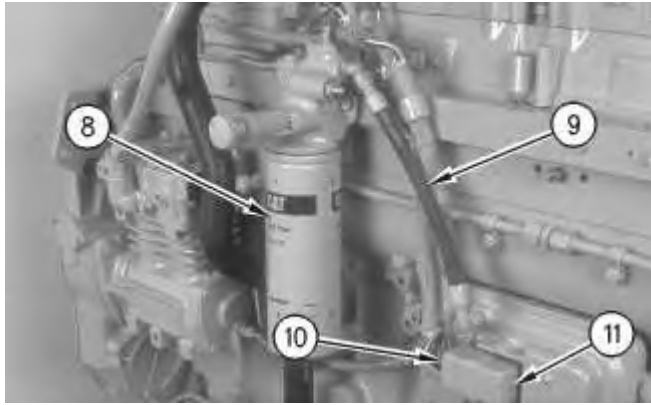

Illustration 3

g00517354

Typical example

6. Use Tooling (A) in order to remove fuel filter (8). Disconnect hose (9). Plug all openings immediately.
7. Loosen bolt (11). Disconnect wiring harness (10) .

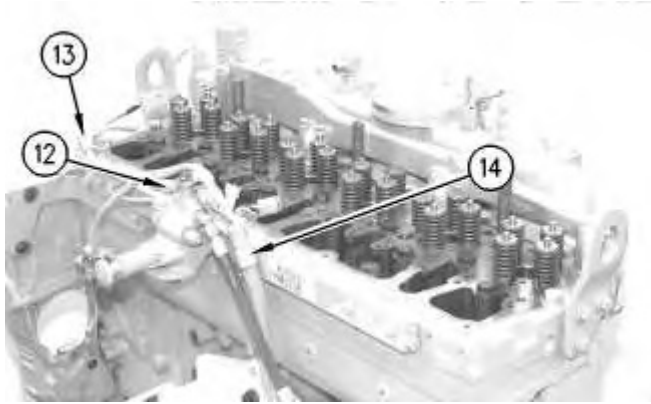
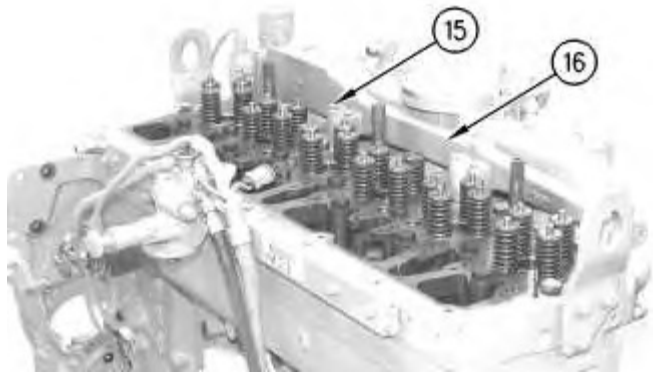

Illustration 4

g00517355

Typical example

8. Disconnect sensor connector (13) and clips (12). Remove clip (14) and the bolt.
-



---

Illustration 5

g00517356

Typical example

9. Remove bolts (15) .
10. Remove water outlet manifold (16) .

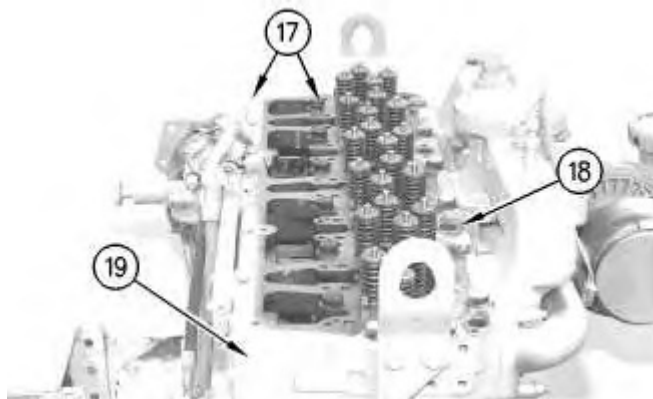

---

Illustration 6

g00517359

11. Remove head bolts (17) .
  12. Remove water outlet manifold gaskets (18) from cylinder head (19) .
-



Illustration 7

g00517361

13. Attach a suitable lifting device to cylinder head (19). Remove cylinder head (19) from the cylinder block. The weight of cylinder head (19) is 135 kg (300 lb).
14. Remove cylinder head gasket (20) and O-ring seals (21) from the cylinder block.

[Previous Screen](#)

Product: EXCAVATOR

Model: 345B II EXCAVATOR CCC

Configuration: 345B Series II Excavator CCC00001-UP (MACHINE) POWERED BY 3176C Engine

## Disassembly and Assembly 3176C and 3196 Engines for Caterpillar Built Machines

Media Number -REN1223-15

Publication Date -01/08/2015

Date Updated -03/08/2015

i01792874

# Cylinder Head - Install

SMCS - 1100-012

## Installation Procedure

Table 1

| Required Tools |                        |  |     |
|----------------|------------------------|--|-----|
| Tool           | Part Number            | Part Description                             | Qty |
| A              | 185-3630               | Strap Wrench Assembly                        | 1   |
| B              | 1U-5686 <sup>(1)</sup> | 21/32 inch Drill Bit                         | 1   |
| C              | 4C-9732 <sup>(1)</sup> | M16x2.0-D7 Plug Tap                          | 1   |
| D              | 9U-5604                | M16x2.0 32mm Heli-Coil Insert <sup>(2)</sup> | 1   |
| E              | 8T-2799 <sup>(1)</sup> | Heli-Coil Installation Tool                  | 1   |
| F              | 8T-3096                | Plug Tap                                     | 1   |
| G              | 6V-4876                | Lubricant                                    | 1   |

<sup>(1)</sup> Part of 4C-8367 Thread Repair Kit

<sup>(2)</sup> This is a special length.

---

### NOTICE

**Keep all parts clean from contaminants.**

**Contaminants may cause rapid wear and shortened component life.**

---

**Note:** For more information, refer to Video Tape, LEVN5101, "C-10 and C-12 Head Gasket Repair Procedure".

1. Thoroughly clean the mating surfaces of the cylinder head and the cylinder block.

2. Clean all 26 head bolt holes on the cylinder block with Tooling (F) .
3. After cleaning the threads, remove any debris from the head bolt holes on the cylinder block with a vacuum line.
4. Visually inspect the head bolt holes on the cylinder block for thread damage.
5. If a damaged head bolt thread is observed, repair the damaged head bolt thread with a Heli-Coil thread repair kit.
6. Inspect the cylinder head and the cylinder block for flatness. Refer to Guideline for Reusable Parts and Salvage Operations, SEBF8162, "Procedure to Measure and Salvage Cylinder Head Assemblies and Related Components".

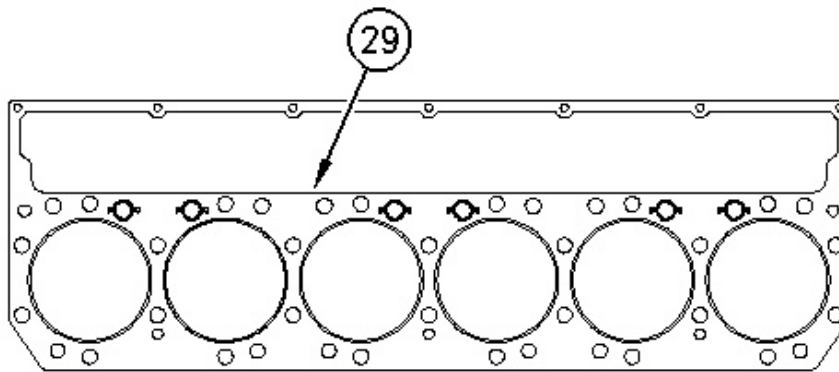

---

Illustration 1

g00810396

Cylinder Head Gasket

(29) Straight Edge

---

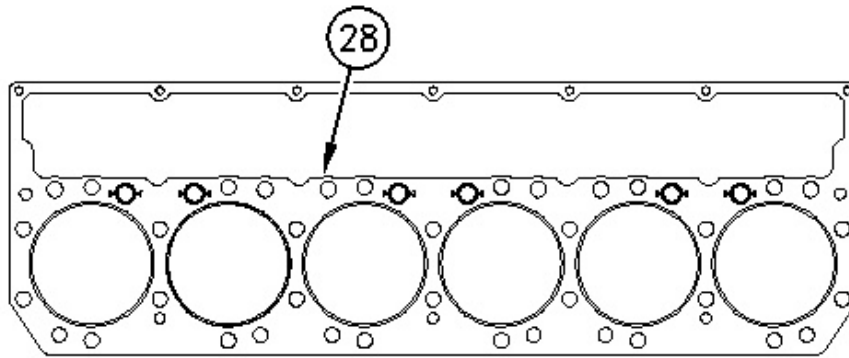

---

Illustration 2

g00810399

Cylinder Head Gasket

(28) Scalloped Edge

7. Determine the correct cylinder head gasket to use. Refer to Illustration 1 and Illustration 2.

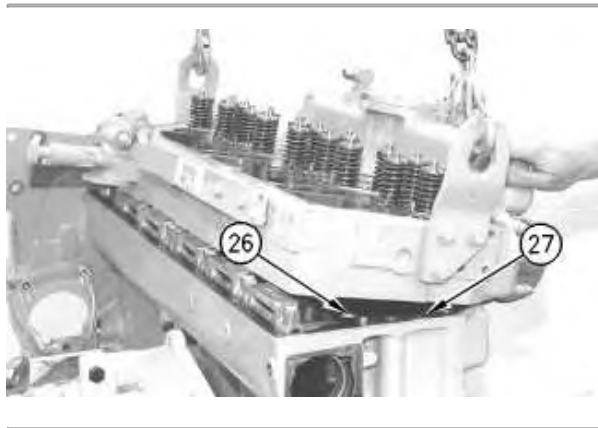

---

Illustration 3

g00525775

8. Install the correct cylinder head gasket (26) and new O-ring seals (27) on the cylinder block. Inspect the condition of the remaining gaskets. Replace the gaskets, if necessary.

**Note:** To avoid damage to the cylinder head gasket, use guide bolts of an appropriate size to install the cylinder head.

9. Use a suitable lifting device to install the cylinder head on the cylinder block.
-

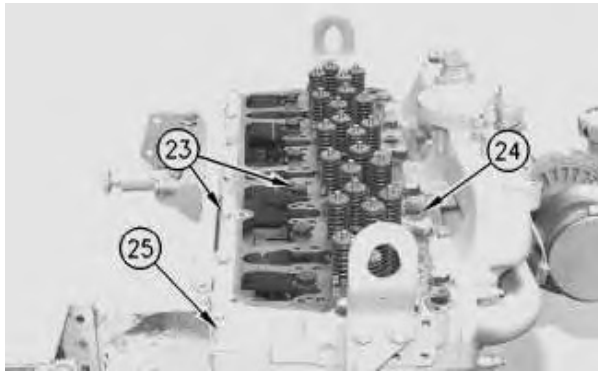

Illustration 4

g00525534

10. Install four gaskets (24) on cylinder head (25) .
11. Install new cylinder head bolts (23). If the engine is equipped with a compression brake, then also install new head bolt studs.
12. Lubricate the following components with Tooling (G) : the bolt threads, the underside of the bolt heads and the washers. Follow Step 13 for the correct tightening procedure.

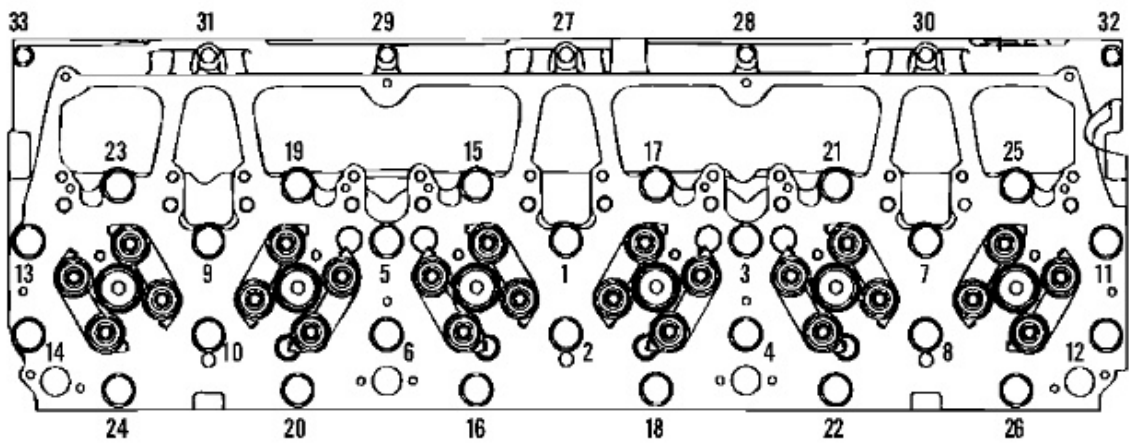

Illustration 5

g00517501

**Note:** Engines that are equipped with a compression brake will have three head bolt studs. Install the head bolt studs in positions (2), (8), and (10). Tighten the head bolt studs in sequence with the cylinder head bolts.

13. Tighten the cylinder head bolts according to the following procedure:
  - a. Tighten bolt (1) through bolt (26) in a numerical sequence to a torque of  $160 \pm 15 \text{ N}\cdot\text{m}$  ( $120 \pm 11 \text{ lb ft}$ ).
  - b. Tighten bolt (1) through bolt (26) again in a numerical sequence to a torque of  $160 \pm 15 \text{ N}\cdot\text{m}$  ( $120 \pm 11 \text{ lb ft}$ ).
  - c. Place an index mark on each bolt head. Turn bolt (1) through bolt (26) in a numerical sequence for an additional 90 degrees ( $1/4$  turn).

- d. **Loosen bolt (1) through bolt (26) until the washers are loose under the bolt heads.**
- e. Tighten bolt (1) through bolt (26) in a numerical sequence to a torque of  $160 \pm 15 \text{ N}\cdot\text{m}$  ( $120 \pm 11 \text{ lb ft}$ ).
- f. Tighten bolt (1) through bolt (26) again in a numerical sequence to a torque of  $160 \pm 15 \text{ N}\cdot\text{m}$  ( $120 \pm 11 \text{ lb ft}$ ).
- g. Place an index mark on each bolt head. Turn bolt (1) through bolt (26) in a numerical sequence for an additional 90 degrees ( $1/4$  turn).
- h. Tighten bolt (27) through bolt (33) in a numerical sequence to a torque of  $28 \pm 7 \text{ N}\cdot\text{m}$  ( $20 \pm 5 \text{ lb ft}$ ).

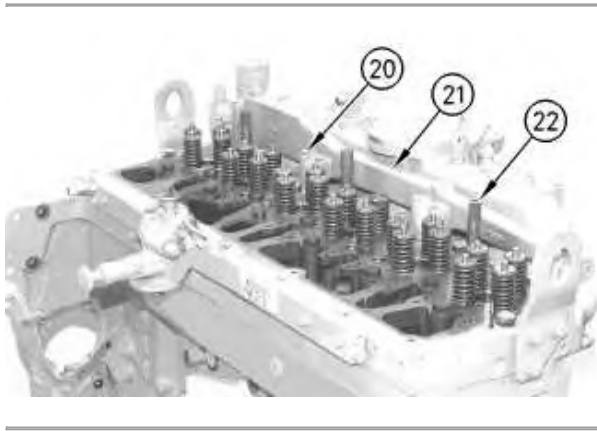

Illustration 6

g00525468

14. Install head bolt spacers (22) on the three head bolt studs. Tighten head bolt spacers (22) to a torque of  $100 \pm 20 \text{ N}\cdot\text{m}$  ( $75 \pm 15 \text{ lb ft}$ ).
15. Install water outlet manifold (21) and bolts (20) .

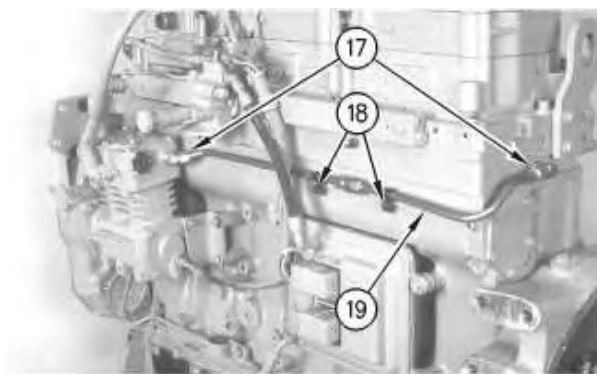

Illustration 7

g00814600

16. Hold line (19) in position and connect fittings (17). Install bolts (18) .
-

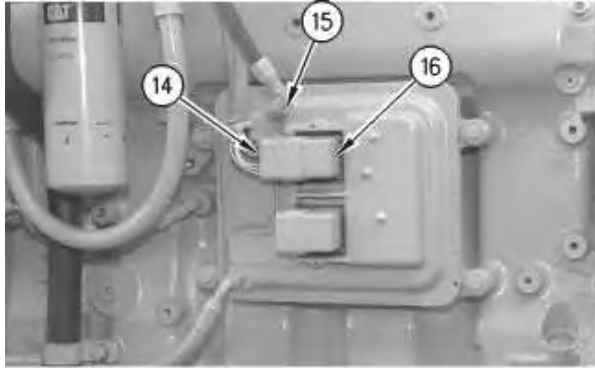

Illustration 8

g00676967

17. Connect wiring harness (14). Tighten bolt (16) to a torque of  $6 \pm 1 \text{ N}\cdot\text{m}$  ( $53 \pm 9 \text{ lb in}$ ).
18. Connect hose (15) .

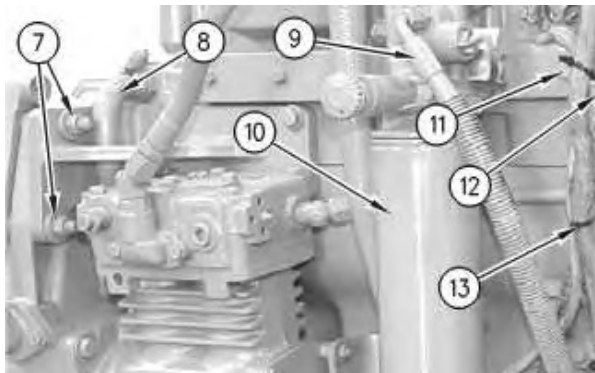

Illustration 9

g00676971

19. Connect sensor connector (12). Install the clip, the washer, and bolt (11). Secure the wiring harness with tie straps (13) .
20. Install fuel filter (10) with Tool (A). Follow the instructions on the fuel filter.
21. Connect hose (9) .
22. Install hose (8) .
23. Install the bolts, the washers, and two nuts (7) .

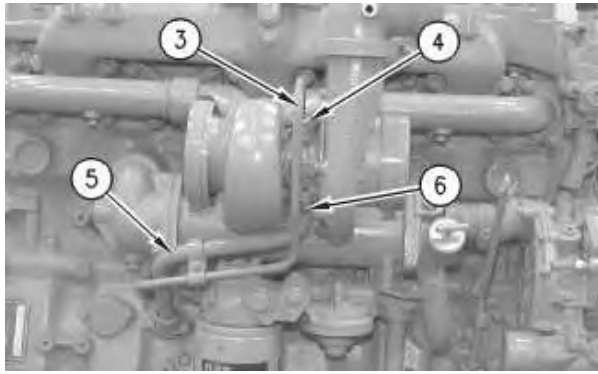

Illustration 10

g00525386

24. Install tube assembly (5) with the O-ring seals, two bolts (6), and the washers.
25. Install tube assembly (3) with the O-ring seal, two bolts (4), and the washers. Install the clip and the bolt to tube assembly (5) and (3) .



Illustration 11

g00524436

26. Route wiring harness (1) accordingly and connect sensor connector (2) .
27. Fill the cooling system with coolant to the correct level. Refer to the Operation and Maintenance Manual for the correct filling procedure.

**End By:**

- a. Install the rocker shaft and the pushrods. Refer to Disassembly and Assembly, "Rocker Shaft and Pushrods - Install".
- b. Install the valve cover base. Refer to Disassembly and Assembly, "Valve Mechanism Cover Base - Remove and Install".

[Previous Screen](#)

Product: EXCAVATOR

Model: 345B II EXCAVATOR CCC

Configuration: 345B Series II Excavator CCC00001-UP (MACHINE) POWERED BY 3176C Engine

## Disassembly and Assembly 3176C and 3196 Engines for Caterpillar Built Machines

Media Number -REN1223-15

Publication Date -01/08/2015

Date Updated -03/08/2015

i02087499

# Lifter Group - Remove and Install

SMCS - 1209-010

## Removal Procedure

### Start By:

- A. Remove the cylinder head. Refer to Disassembly and Assembly, "Cylinder Head - Remove".

---

### NOTICE

**Keep all parts clean from contaminants.**

**Contaminants may cause rapid wear and shortened component life.**

---

---

### NOTICE

**Care must be taken to ensure that fluids are contained during performance of inspection, maintenance, testing, adjusting and repair of the product. Be prepared to collect the fluid with suitable containers before opening any compartment or disassembling any component containing fluids.**

**Refer to Special Publication, NENG2500, "Caterpillar Tools and Shop Products Guide" for tools and supplies suitable to collect and contain fluids on Caterpillar products.**

**Dispose of all fluids according to local regulations and mandates.**

---

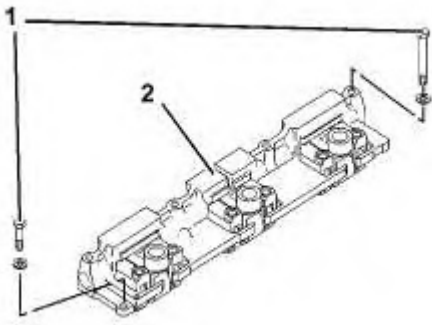

Illustration 1

g01022184

1. Remove bolts (1) and lifter assembly (2). The lifter assembly can be removed in two sections.

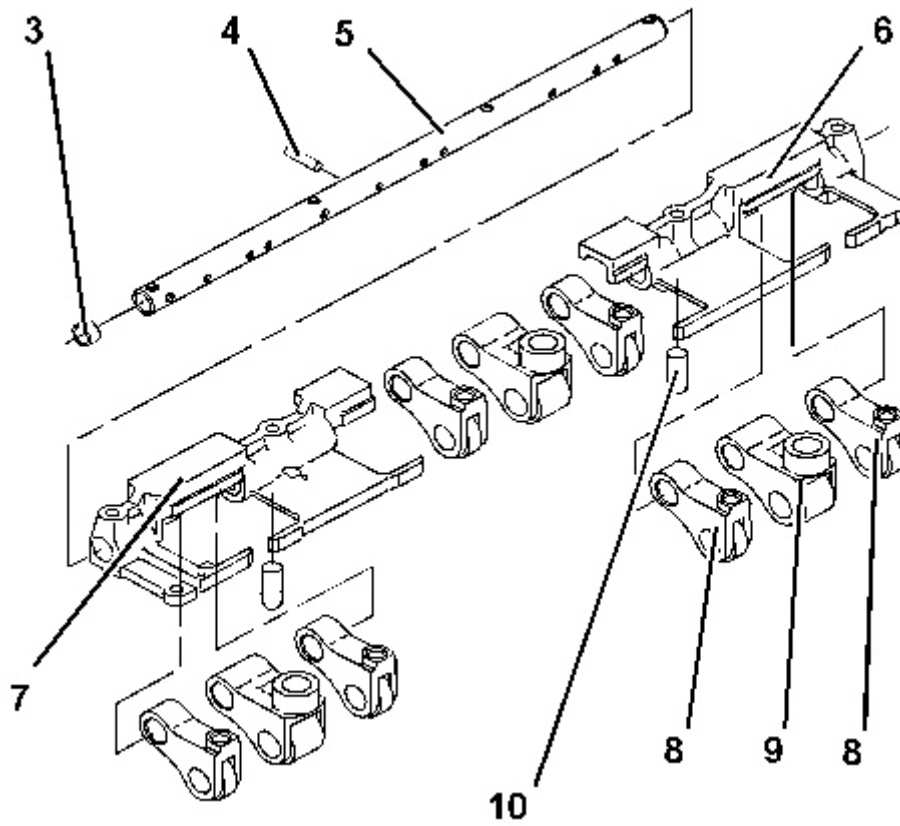

Illustration 2

g01022187

2. Remove the following items from the right end of lifter shaft (5) : bracket assembly (6), valve lifters (8) and unit injector lifter (9) .
3. Remove the following items from the middle of lifter shaft (5) : valve lifters (8) and unit injector lifter (9) .
4. Remove the following items from the left end of lifter shaft (5) : bracket assembly (7), valve lifters (8) and unit injector lifter (9) .
5. Remove dowel (4) and cap plug (3) from lifter shaft (5) .
6. Remove the spring pin from bracket assembly (7), if necessary.
7. Remove dowel (10) from bracket assembly (6), if necessary.

## **Installation Procedure**

---

### **NOTICE**

**Keep all parts clean from contaminants.**

**Contaminants may cause rapid wear and shortened component life.**

---

---

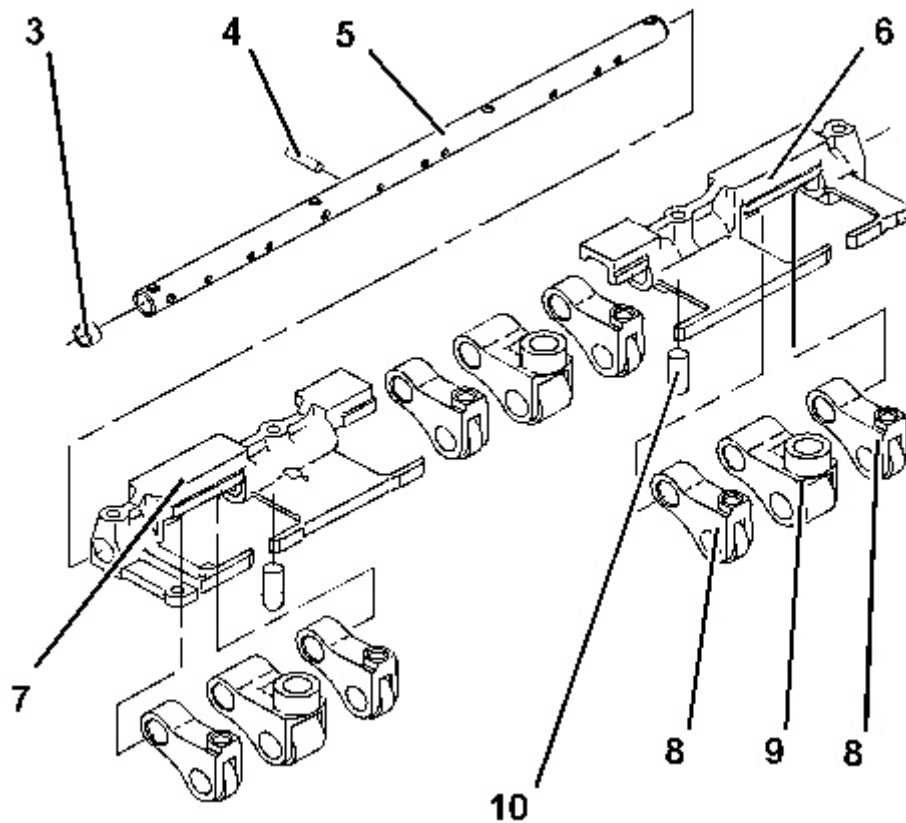

---

Illustration 3

g01022187

1. Install the spring pin and dowel (10) in bracket assembly (6). Install the spring pin and the dowel in bracket assembly (7) .
  2. Install dowel (4) and cap plug (3) in lifter shaft (5). Lubricate the lifter shaft with clean engine oil prior to assembly.
  3. Install the following items on the left end of lifter shaft (5) : bracket assembly (7), valve lifters (8) and unit injector lifter (9) .
  4. Install the following items on the middle of lifter shaft (5) : valve lifters (8) and unit injector lifter (9) .
  5. Install the following items on the right end of lifter shaft (5) : bracket assembly (6), valve lifters (8) and unit injector lifter (9) .
-

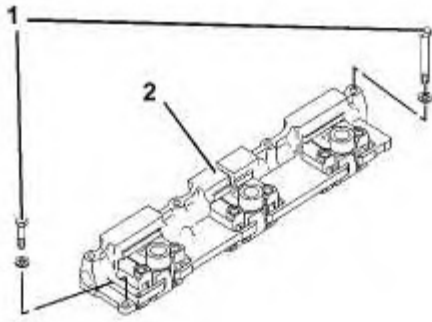

---

Illustration 4

g01022184

**Note:** Immerse the entire lifter assembly in clean engine oil prior to installation on the engine.

6. Place the lifter assembly (2) on the engine and install bolts (1). Tighten the bolts to a torque of  $30 \pm 3 \text{ N}\cdot\text{m}$  ( $22 \pm 2 \text{ lb ft}$ ).

**End By:** Install the cylinder head. Refer to Disassembly and Assembly, "Cylinder Head - Install".

Previous Screen

Product: EXCAVATOR

Model: 345B II EXCAVATOR CCC

Configuration: 345B Series II Excavator CCC00001-UP (MACHINE) POWERED BY 3176C Engine

**Disassembly and Assembly  
3176C and 3196 Engines for Caterpillar Built Machines**

Media Number -REN1223-15

Publication Date -01/08/2015

Date Updated -03/08/2015

i02363444

## Camshaft - Remove

SMCS - 1210-011

### Removal Procedure

Table 1

| Required Tools |             |                  |     |
|----------------|-------------|------------------|-----|
| Tool           | Part Number | Part Description | Qty |
| A              | 131-1525    | Camshaft Pilot   | 1   |

**Start By:**

- A. Remove the rocker shaft and the pushrods. Refer to Disassembly and Assembly, "Rocker Shaft and Pushrod - Remove".
- B. Remove the front cover. Refer to Disassembly and Assembly, "Front Cover - Remove".
- C. Remove the camshaft position sensor. Refer to Disassembly and Assembly, "Camshaft Position Sensor - Remove and Install".

---

**NOTICE**

**Keep all parts clean from contaminants.**

**Contaminants may cause rapid wear and shortened component life.**

---

**NOTICE**

**Care must be taken to ensure that fluids are contained during performance of inspection, maintenance, testing, adjusting and repair**

**of the product. Be prepared to collect the fluid with suitable containers before opening any compartment or disassembling any component containing fluids.**

**Refer to Special Publication, NENG2500, "Caterpillar Dealer Service Tool Catalog" for tools and supplies suitable to collect and contain fluids on Caterpillar products.**

**Dispose of all fluids according to local regulations and mandates.**

---

1. Turn the crankshaft to top center compression stroke for the No. 1 piston. Install the timing bolt in the flywheel. Refer to Testing and Adjusting, "Finding Top Center Position for No. 1 Piston".
2. Ensure that the timing marks on the following gears are aligned: the camshaft drive gear, the idler gear and the crankshaft gear.



---

Illustration 1

g00529917

**Note:** It is not necessary to remove the cylinder head for removal of the camshaft.

3. Wire the valve lifters away from the camshaft. See Illustration 1.
-



**Suggest:**

**If the above button click is invalid.**

**Please download this document first, and then click the above link to download the complete manual.**

**Thank you so much for reading**

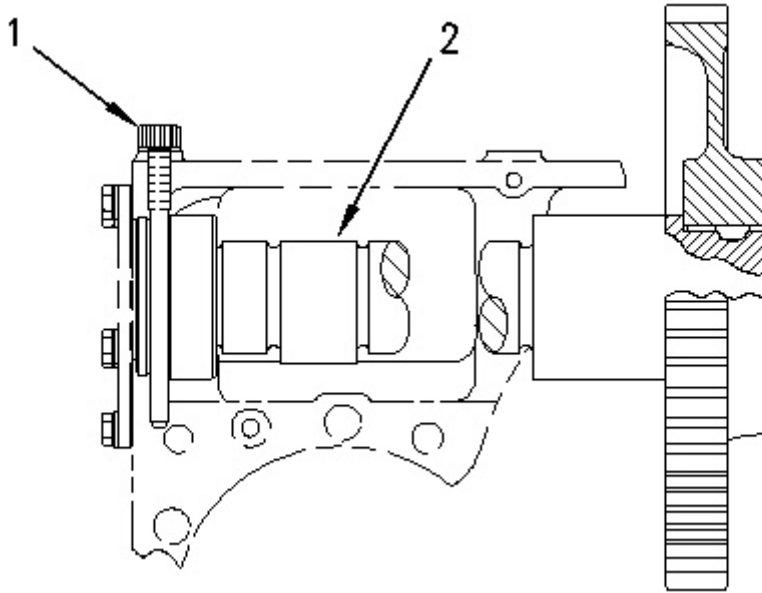

---

Illustration 2

g00813405

4. Remove thrust pin (1) .
5. Install Tooling (A) into camshaft (2) .

**Note:** Lubricate Tooling (A) for easier removal of the camshaft. Lubrication also prevents damaging the camshaft lobes and the camshaft bearings.

6. Carefully remove camshaft (2) from the engine.

**<https://www.ebooklibonline.com>**

Hello dear friend!

Thank you very much for reading.

Enter the link into your browser.

The full manual is available for immediate download.

**<https://www.ebooklibonline.com>**