



# Service Repair Manual

## **Models**

340F L LRE Excavator

---

[Previous Screen](#)

Product: EXCAVATOR

Model: 340F L LRE EXCAVATOR YBF

Configuration: 340F Excavators YBF00001-UP (MACHINE) POWERED BY C9.3 Engine

## Disassembly and Assembly 340F Excavator Machine Systems

Media Number -UENR6797-01

Publication Date -01/09/2015

Date Updated -21/12/2016

i06263999

## Travel Motor - Disassemble

SMCS - 4351-015

S/N - EAR1-UP

S/N - SGH1-UP

S/N - YBF1-UP

## Disassembly Procedure

Table 1

Required Tools			
Tool	Part Number	Part Description	Qty
A	1U-7506	Adapter	1
	8T-4244	Nut	6
	8T-4223	Hard Washer	6
	-	M12 x 1.75 by 250 mm (10 inch) Threaded Rod	1
B	8T-0651	Bolt	1
	8T-4167	Hard Washer	1
C	3E-3882	Eyebolt	1
D	1P-0510	Driver Gp	1
	9S-9152	Bearing Puller Gp	1

### Start By:

- a. Remove the travel motor.



Illustration 1

g00887295

1. Fasten the travel motor in Tooling (A) in a vertical position. The weight of the travel motor is approximately 146 kg (322 lb).
2. Put an alignment mark across the head and the body of the travel motor for assembly purposes. The head must be reinstalled in the head's original position on the body of the travel motor.

 **WARNING**

**Personal injury can result from being struck by parts propelled by a released spring force.**

**Make sure to wear all necessary protective equipment.**

**Follow the recommended procedure and use all recommended tooling to release the spring force.**

---

**Note:** During the removal of head (2) from the travel motor, be careful not to damage the mating surfaces of the components.

3. Remove bolts (1).
  4. Remove head (2) from the body of the travel motor.
-

**<https://www.ebooklibonline.com>**

Hello dear friend!

Thank you very much for reading.

Enter the link into your browser.

The full manual is available for immediate download.

**<https://www.ebooklibonline.com>**

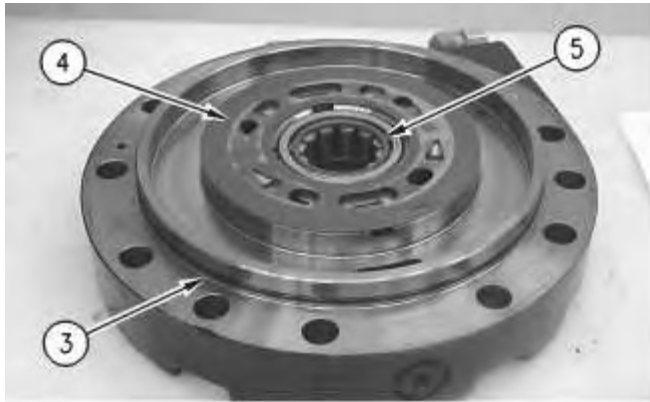

Illustration 2

g00887302

5. Remove O-ring seal (3), port plate (4), and bearing (5).

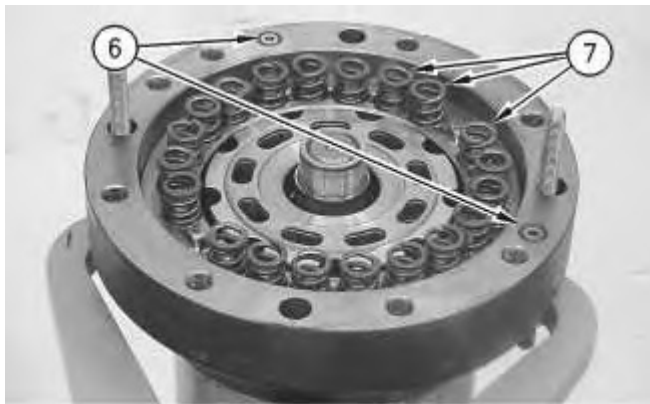

Illustration 3

g00887311

6. Remove O-ring seals (6). Remove springs (7).

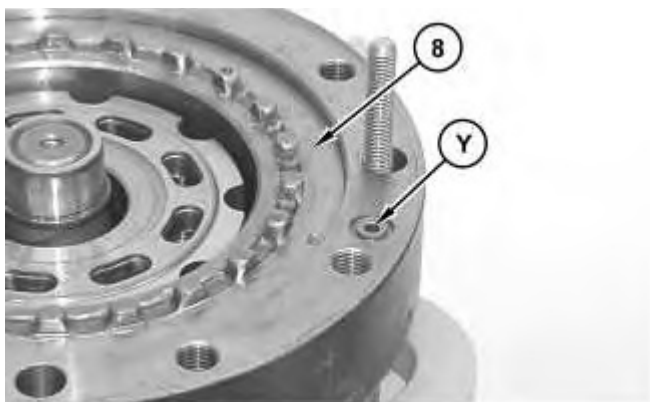

Illustration 4

g03882593

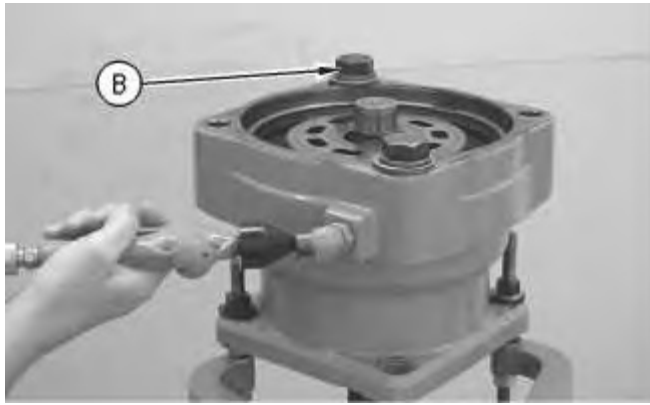

Illustration 5

g00890074

This is an example of the use of Tooling (B).

7. Place a shop towel over brake piston (8). Retain brake piston (8) with Tooling (B). Apply approximately 525 kPa (75 psi) of shop air pressure to brake release Port (Y). Make sure that the shop air pressure is free of water. Brake piston (8) will move up the piston guide, and out of the piston guide. Remove brake piston (8) from the body of the travel motor.



Illustration 6

g00887336

8. Remove seal (9) and backup ring (10) from the brake piston.
9. Remove seal (11) and backup ring (12) from the brake piston.



10. Remove plates (13) and friction discs (14).

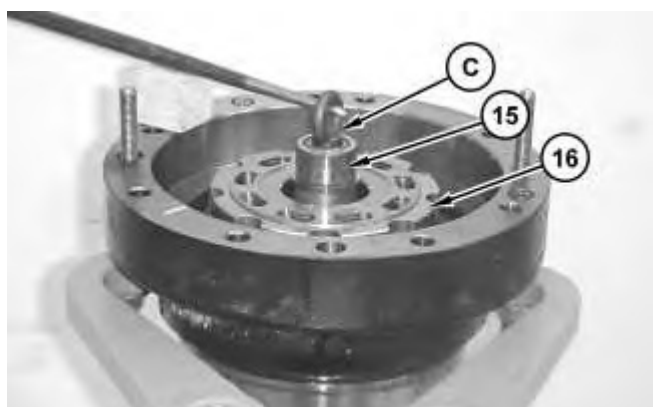

Illustration 8

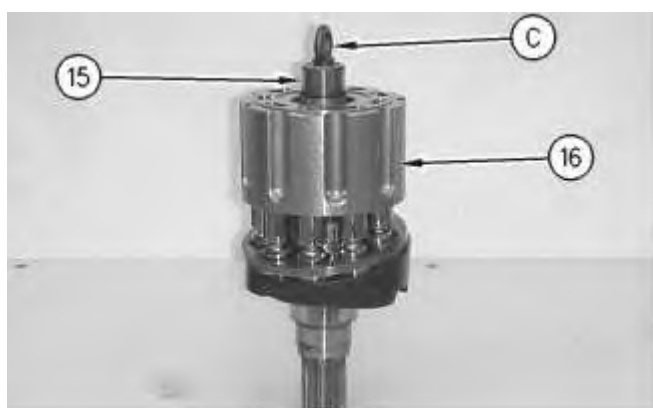

Illustration 9

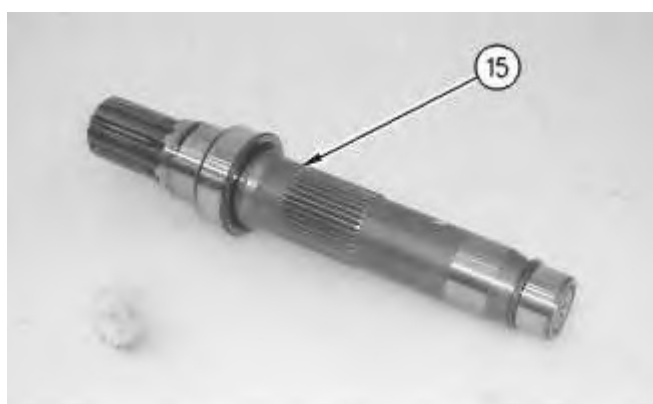

Illustration 10

11. Install Tooling (C) into shaft (15). Use a prybar to remove the rotating assembly (16) from the housing.
12. Remove Tooling (C) from shaft (15).

13. Remove shaft (15) from rotating assembly (16).

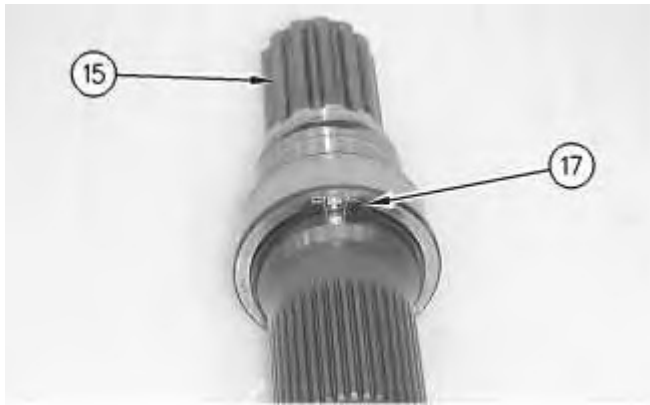

Illustration 11

g00887426

14. Remove retaining ring (17) from shaft (15).

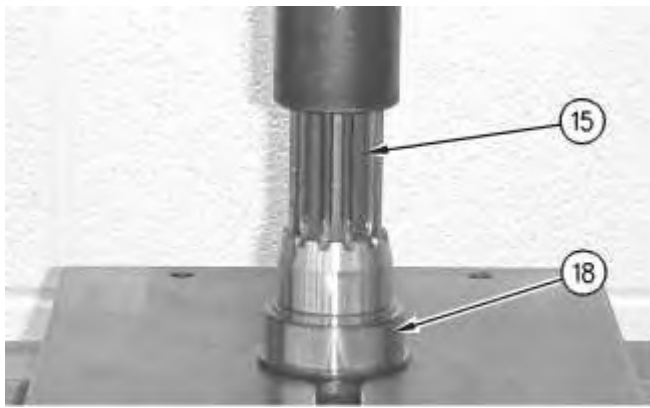

Illustration 12

g00887445

15. Use a suitable press in order to remove bearing race (18) from shaft (15).

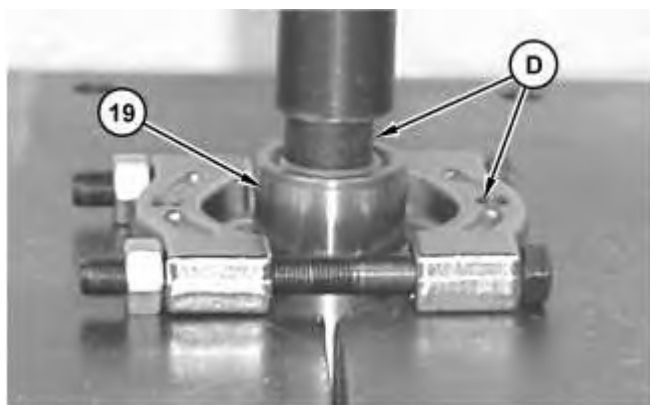

Illustration 13

g03882594

16. Rotate shaft (15). Use a suitable press and Tooling (D) to remove bearing race (19) from shaft (15).

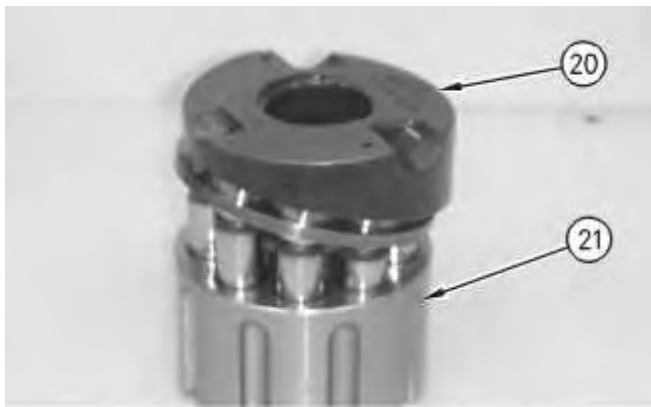

Illustration 14

g00887501

17. Remove cam plate (20) from barrel assembly (21).

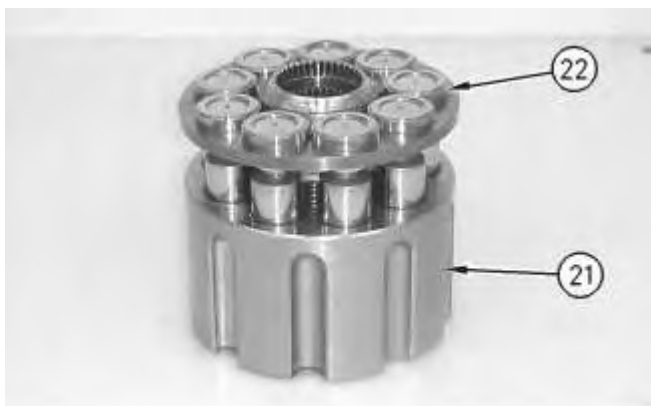

Illustration 15

g00887520

18. Remove piston assemblies and retainer plate (22) from barrel assembly (21).

**Note:** Place marks on the pistons and the barrel assembly. The pistons must be returned to the original position.



Illustration 16

g00887558

## **WARNING**

**Personal injury can result from being struck by parts propelled by a released spring force.**

**Make sure to wear all necessary protective equipment.**

**Follow the recommended procedure and use all recommended tooling to release the spring force.**

---

19. Remove ball (23) and springs (24).

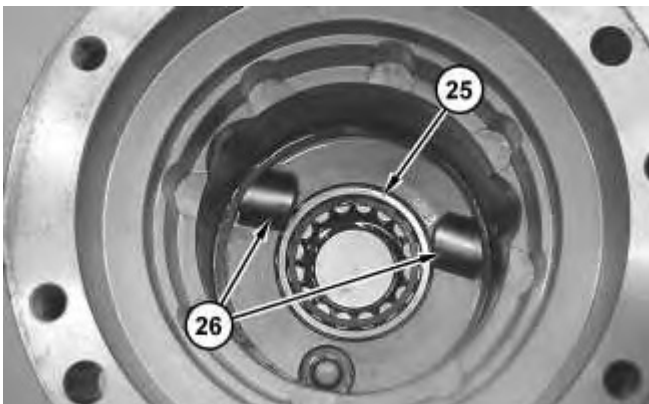

Illustration 17

g02107975

20. Remove bearing (25).
21. Remove keys (26) and locating pins (not shown) from the body of the travel motor.
- 



Illustration 18

g00887589

22. Rotate the housing and remove retaining ring (27).
23. Remove lip seal (28).
-

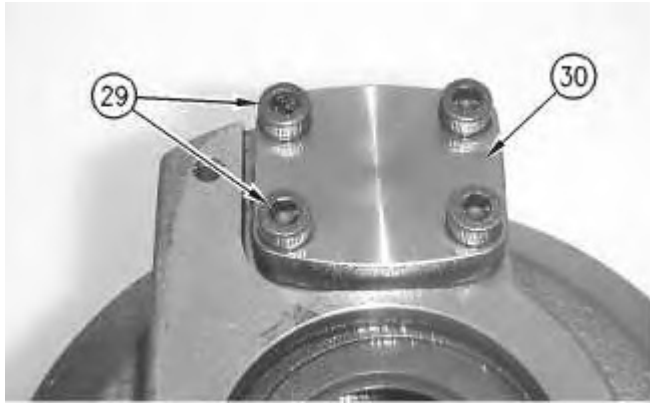

Illustration 19

g00887619

24. Remove bolts (29) and cover (30).



Illustration 20

g00887729

25. Remove seal (31) and backup ring (32).



Illustration 21

g00887754

26. Remove piston actuator (33) and seal (34).



---

Illustration 22

g00887762

27. Remove O-ring seal (35) from the housing of the travel motor.

[Previous Screen](#)

Product: EXCAVATOR

Model: 340F L LRE EXCAVATOR YBF

Configuration: 340F Excavators YBF00001-UP (MACHINE) POWERED BY C9.3 Engine

## Disassembly and Assembly 340F Excavator Machine Systems

Media Number -UENR6797-01

Publication Date -01/09/2015

Date Updated -21/12/2016

i06264026

## Travel Motor - Assemble

SMCS - 4351-016

S/N - EAR1-UP

S/N - SGH1-UP

S/N - YBF1-UP

## Assembly Procedure

Table 1

Required Tools			
Tool	Part Number	Part Description	Qty
A	1U-7506	Adapter	1
	8T-4244	Nut	6
	8T-4223	Hard Washer	6
	-	M12 x 1.75 X 250 mm (10 inch) Threaded Rod	1
C	3E-3882	Eyebolt	1
D	1P-0510	Driver Gp	1
	9S-9152	Bearing Puller Gp	1
E	-	Loctite 243	-



Illustration 1

g00887762

1. Install O-ring seal (35) onto the housing of the travel motor.



Illustration 2

g00887754

2. Install seal (34) and piston actuator (33). Lubricate the surfaces of piston actuator (33) with lubricant that is being sealed.



Illustration 3

g00887729

3. Install backup ring (32) and seal (31).

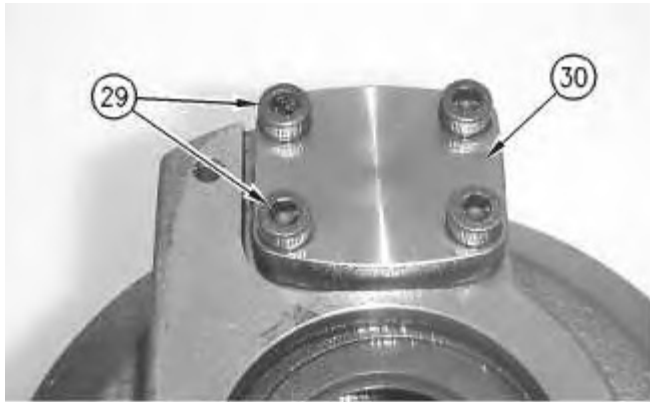

Illustration 4

g00887619

4. Install cover (30) and bolts (29). Tighten bolts (29) to a torque of  $28 \pm 7$  N·m ( $21 \pm 5$  lb ft).



Illustration 5

g00887589

5. Apply Tooling (E) to the mating surface of lip seal (28). Use Tooling (E) to install lip seal (28). Lubricate the sealing lip of lip seal (28) with lubricant that is being sealed.
6. Install retaining ring (27).

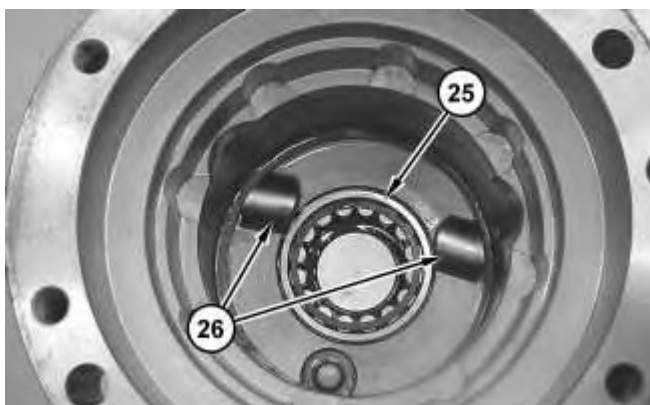

Illustration 6

g02107975

7. Rotate the housing.

8. Install keys (26) and locating pins (not shown) into the body of the travel motor.
9. Install bearing (25).



Illustration 7

g00887558

 **WARNING**

**Improper assembly of parts that are spring loaded can cause bodily injury.**

**To prevent possible injury, follow the established assembly procedure and wear protective equipment.**

---

10. Install springs (24) into the barrel assembly. Install ball (23) onto springs (24). Lubricate ball (23) with lubricant that is being sealed.

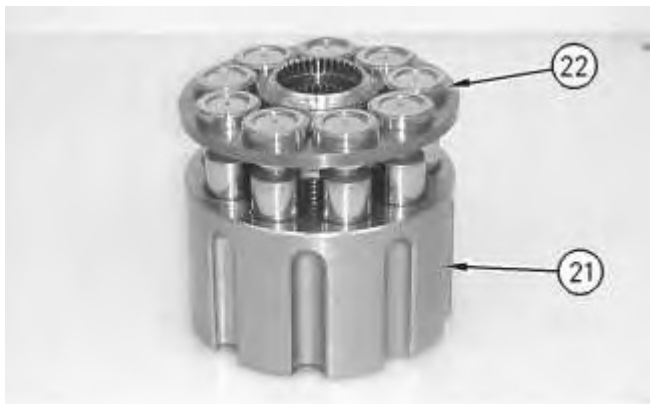

Illustration 8

g00887520

11. Lubricate the piston assemblies with lubricant that is being sealed. Install piston assemblies and retainer plate (22) into barrel assembly (21).

**Note:** Take note of the mark on the piston assembly and the barrel assembly. The pistons must be returned to the same position.

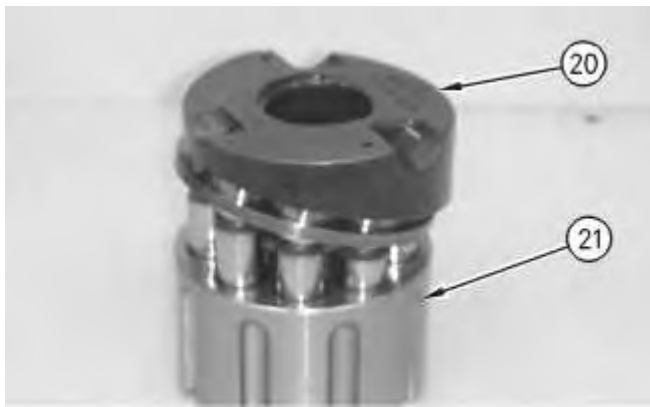

Illustration 9

g00887501

12. Lubricate cam plate (20) with lubricant that is being sealed. Install cam plate (20) onto barrel assembly (21).

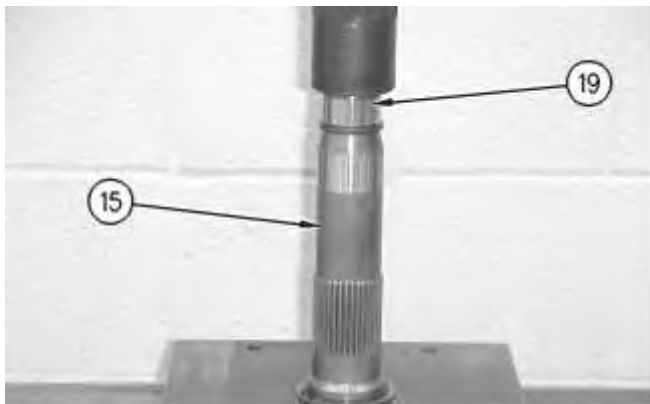

Illustration 10

g00888697

13. Install shaft (15) into a suitable press. Install bearing race (17) onto shaft (15).

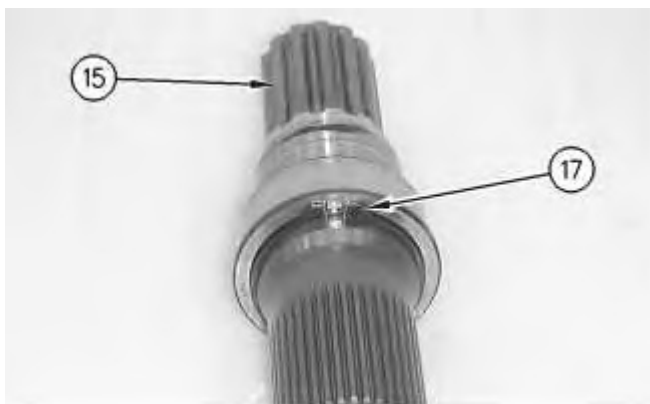

Illustration 11

g00887426

14. Rotate shaft (15) in the suitable press. Install retaining ring (17) onto shaft (15).

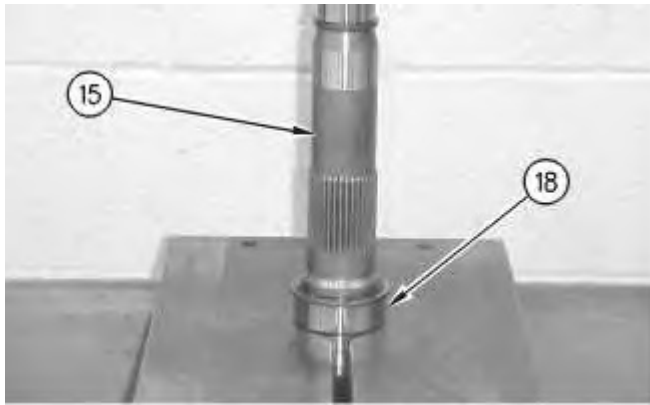

Illustration 12

g00888710

15. Install bearing race (18) onto shaft (15).

**Note:** Bearing race (18) must contact retaining ring (17).

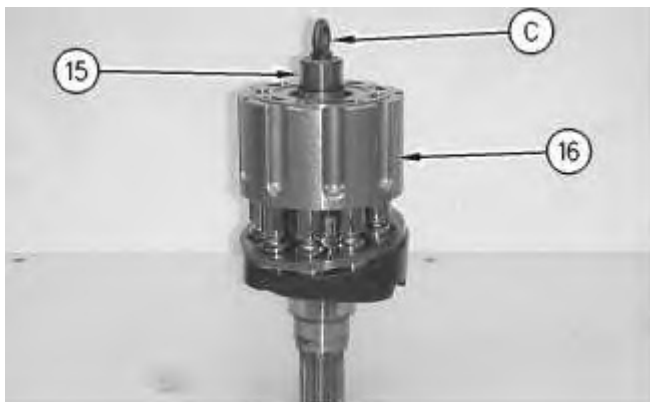
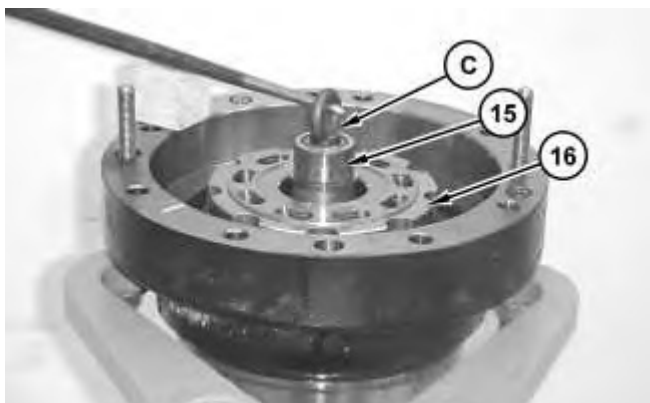

Illustration 13

g00887405

16. Install Tooling (C) into shaft (15). Install shaft (15) into rotating assembly (16).

17. Place the pump housing into Tooling (A).



18. Use Tooling (C) to install rotating assembly (16) into the housing.



Illustration 15

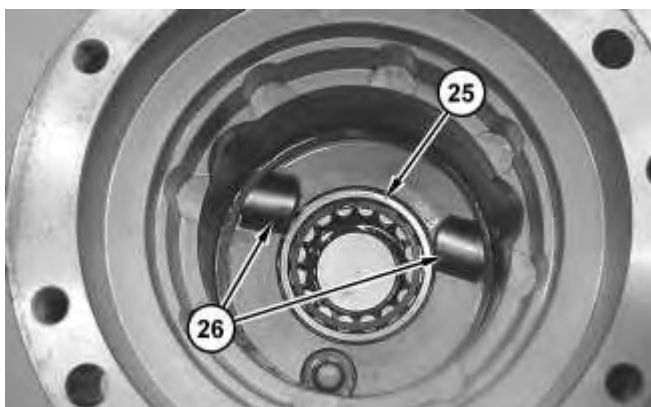

Illustration 16

19. The notches in cam plate (20) must align with keys (26). The keys are located in the bottom of the housing of the travel motor.

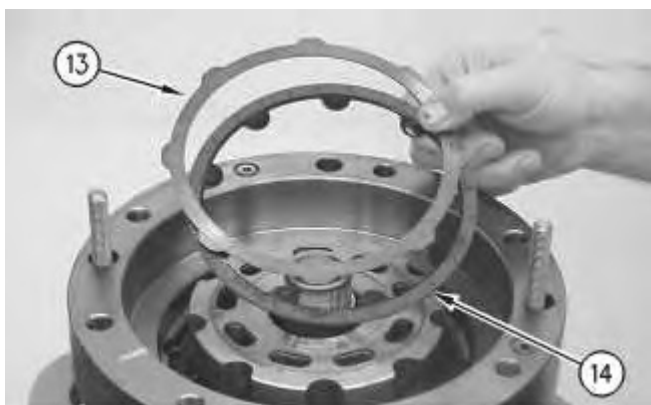

Illustration 17

20. Install plates (13) and friction discs (14) into the housing.

**Note:** Install the plates and the discs alternately.



Illustration 18

g00887336

21. Install backup ring (12) and seal (11) onto the brake piston.
22. Install backup ring (10) and seal (9) onto the brake piston.

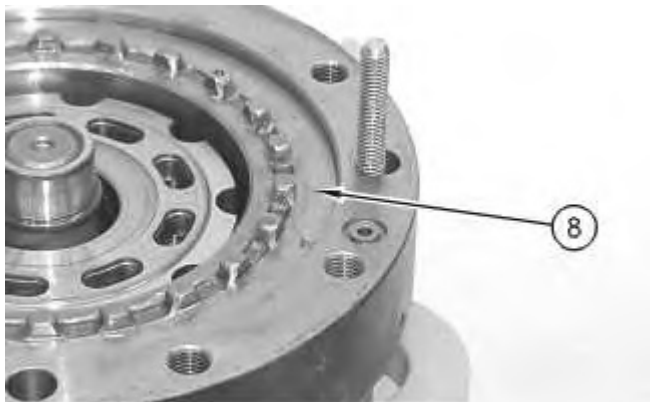

Illustration 19

g00888967

23. Rotate brake piston (8).
24. Install brake piston (8) into the housing.

**Note:** Brake piston (8) must be level upon installation. The brake piston must be level to prevent damage to the O-ring seals.

---

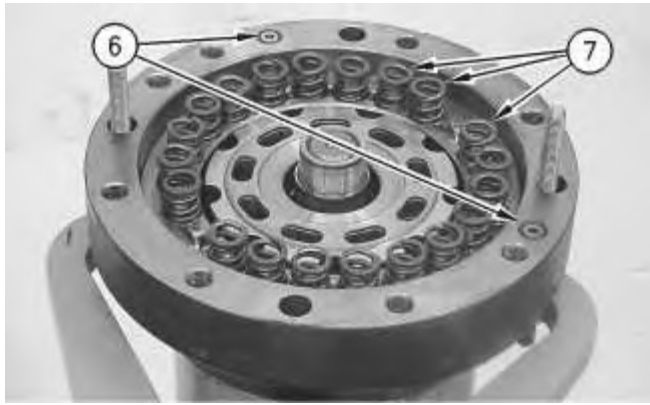

Illustration 20

g00887311

25. Install springs (7) and O-ring seals (6).

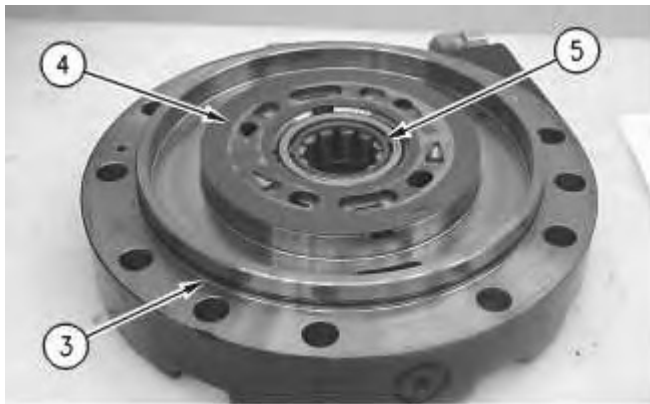

Illustration 21

g00887302

26. Lubricate port plate (4) with lubricant that is being sealed. Install O-ring seal (3), port plate (4), and bearing (5).



Illustration 22

g00887295

 **WARNING**

**Improper assembly of parts that are spring loaded can cause bodily injury.**

**To prevent possible injury, follow the established assembly procedure and wear protective equipment.**

---

27. Install head (2) onto the body of the travel motor.

**Note:** During the installation of head (2) onto the travel motor, be careful not to damage the mating surfaces of the components.

28. Install bolts (1). Tighten bolts (1) to a torque of  $240 \pm 40$  N·m ( $177 \pm 30$  lb ft).

**End By:**

a. Install the travel motor.

---

[Previous Screen](#)

Product: EXCAVATOR

Model: 340F L LRE EXCAVATOR YBF

Configuration: 340F Excavators YBF00001-UP (MACHINE) POWERED BY C9.3 Engine

## Disassembly and Assembly 340F Excavator Machine Systems

Media Number -UENR6797-01

Publication Date -01/09/2015

Date Updated -21/12/2016

i06264081

# Final Drive and Travel Motor - Remove and Install

SMCS - 4050; 4351

S/N - EAR1-UP

S/N - SGH1-UP

S/N - YBF1-UP

## Removal Procedure

Table 1

Required Tools			
Tool	Part Number	Part Description	Qty
A	1U-9200	Lever Puller Hoist	1
B	439-3938	Link Bracket	1
C	-	Loctite C5A Copper Anti Seize	

**WARNING**

**Personal injury can result from hydraulic oil pressure and hot oil.**

**Hydraulic oil pressure can remain in the hydraulic system after the engine has been stopped. Serious injury can be caused if this pressure is not released before any service is done on the hydraulic system.**

**Make sure all of the work tools have been lowered to the ground, and the oil is cool before removing any components or lines. Remove the oil**

**filler cap only when the engine is stopped, and the filler cap is cool enough to touch with your bare hand.**

---

1. Refer to Operation and Maintenance Manual, "Final Drive Oil - Change" for the correct draining and filling procedures.

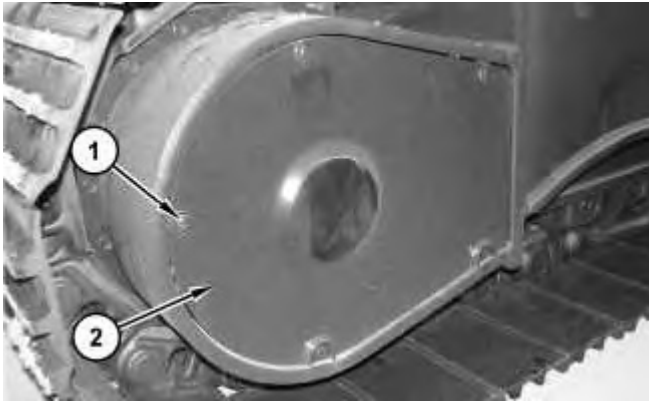

Illustration 1

g02108761

2. Remove bolts (1) and cover (2).
3. Separate the track.

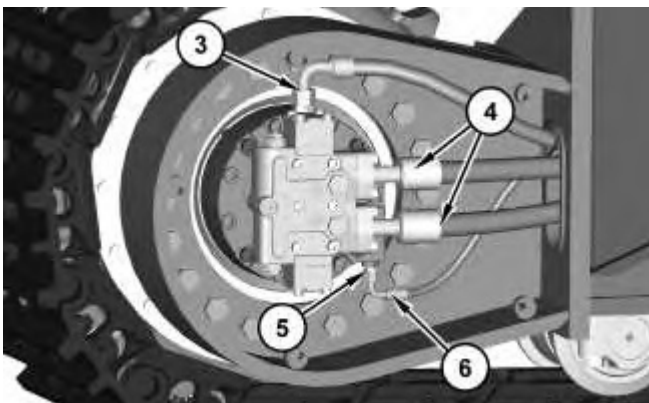

Illustration 2

g02108762

4. Disconnect hose assemblies (3), (4), and (6). Remove fitting (5).
-

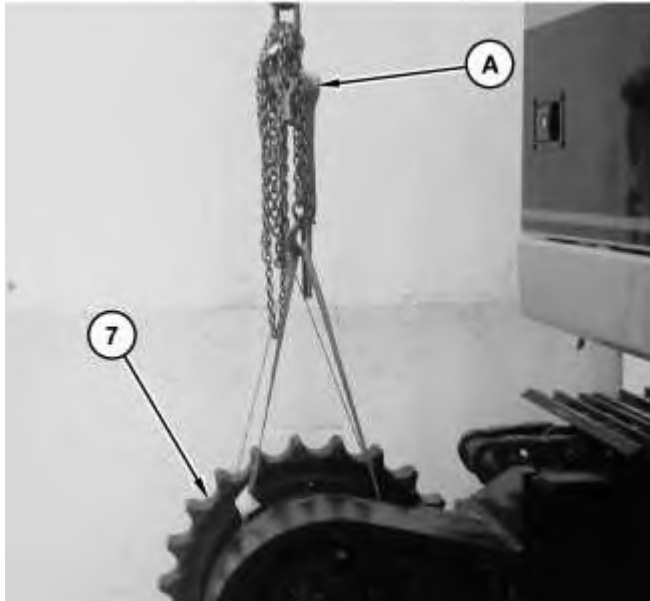

Illustration 3

g02108781

5. Attach Tooling (A) and a suitable lifting device to final drive and travel motor (7). The weight of final drive and travel motor (7) is approximately 635 kg (1400 lb). Put a slight lifting tension on final drive and travel motor (7).



Illustration 4

g02108790

**Note:** Mark the orientation of the final drive and travel motor assembly for installation purposes.

6. Remove bolts (8).

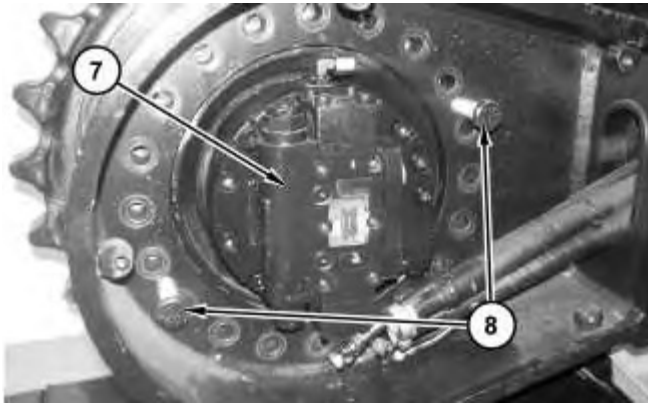

Illustration 5

g02108791

7. Use two bolts (8) in order to remove final drive and travel motor (7).
8. Carefully remove final drive and travel motor (7).
9. Remove bolts (8) from the frame.

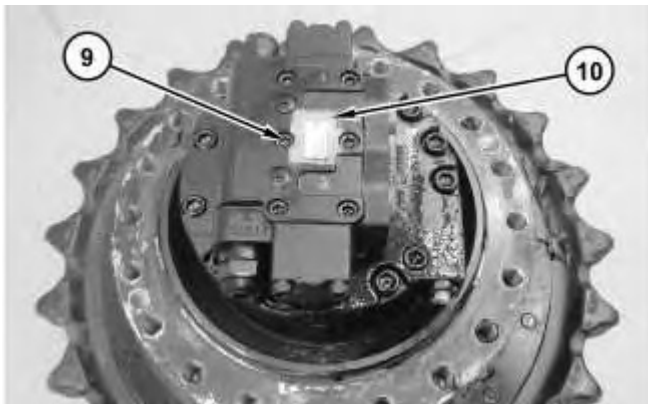

Illustration 6

g02108793

10. Remove bolts (9), counterbalance valve (10), and the O-ring seals.



**Suggest:**

**If the above button click is invalid.**

**Please download this document**

**first, and then click the above link**

**to download the complete manual.**

**Thank you so much for reading**

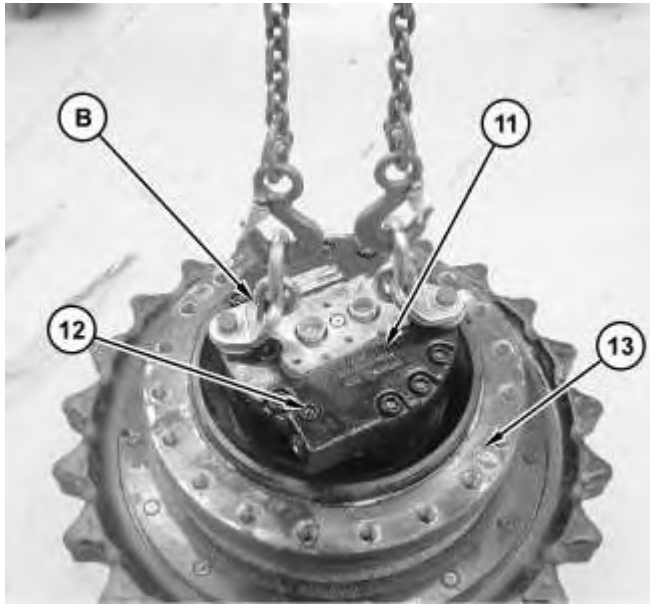

Illustration 7

g02108794

11. Attach Tooling (B) and a suitable lifting device to travel motor (11). The weight of travel motor (11) is approximately 146 kg (322 lb).
12. Remove four bolts (12) and travel motor (11) from final drive (13).

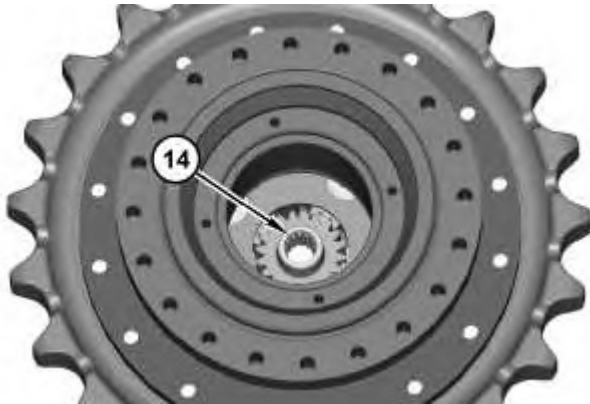

Illustration 8

g02108914

13. Remove coupling (14).

## Installation Procedure

1. Install final drive and travel motor (7) in the reverse order of removal.
  - a. Tighten bolts (9) to a torque of  $80 \pm 8 \text{ N}\cdot\text{m}$  ( $60 \pm 6 \text{ lb ft}$ ).
  - b. Apply Tooling (C) to the threads of bolts (8).
  - c. Tighten bolts (8) to a torque of  $900 \pm 100 \text{ N}\cdot\text{m}$  ( $665 \pm 75 \text{ lb ft}$ ).
  - d. Tighten hose assembly (3) to a torque of  $160 \pm 16 \text{ N}\cdot\text{m}$  ( $120 \pm 12 \text{ lb ft}$ ).

**<https://www.ebooklibonline.com>**

Hello dear friend!

Thank you very much for reading.

Enter the link into your browser.

The full manual is available for immediate download.

**<https://www.ebooklibonline.com>**