



Service Repair Manual

Models

330D L and 330D N
Hydraulic Excavator

[Previous Screen](#)

Product: EXCAVATOR

Model: 330D L EXCAVATOR RAS

Configuration: 330D L & 330D N Hydraulic Excavator RAS00001-UP (MACHINE) POWERED BY C-9 Engine

Disassembly and Assembly

330D, 336D, 336D2, 340D and 340D2 Excavators and 336D MHPU Mobile Hydraulic Power Unit Machine Systems

Media Number -REN8648-30

Publication Date -01/03/2015

Date Updated -15/08/2018

i02451126

Final Drive and Travel Motor - Remove

SMCS - 4050-011; 4351-011

Removal Procedure

Table 1

Required Tools			
Tool	Part Number	Part Description	Qty
A	5P-0306	Vacuum Transducer	1
	FT-1115	Vacuum Cap	1
	6V-4142	Fitting	1
	5K-5068	Fitting	1
B	1U-9200	Lever Puller Hoist	1
C	138-7573	Link Bracket	1

Note: Put identification marks on all hose assemblies, fittings and ports so that all the components can be reassembled in the original configuration. Plug all of the hose assemblies and cap all of the fittings. This helps to prevent fluid loss and this helps to keep contaminants from entering the system.

NOTICE

Care must be taken to ensure that fluids are contained during performance of inspection, maintenance, testing, adjusting, and repair of the product. Be prepared to collect the fluid with suitable containers

before opening any compartment or disassembling any component containing fluids.

Refer to Special Publication, NENG2500, "Dealer Service Tool Catalog" for tools and supplies suitable to collect and contain fluids on Cat products.

Dispose of all fluids according to local regulations and mandates.

NOTICE

Keep all parts clean from contaminants.

Contaminants may cause rapid wear and shortened component life.

! WARNING

Personal injury can result from hydraulic oil pressure and hot oil.

Hydraulic oil pressure can remain in the hydraulic system after the engine has been stopped. Serious injury can be caused if this pressure is not released before any service is done on the hydraulic system.

Make sure all of the work tools have been lowered to the ground, and the oil is cool before removing any components or lines. Remove the oil filler cap only when the engine is stopped, and the filler cap is cool enough to touch with your bare hand.



Illustration 1

g01223707

<https://www.ebooklibonline.com>

Hello dear friend!

Thank you very much for reading.

Enter the link into your browser.

The full manual is available for immediate download.

<https://www.ebooklibonline.com>

1. Remove bolts (1) and cover (2).
2. Separate the track. Refer to Disassembly and Assembly, "Track - Separate".

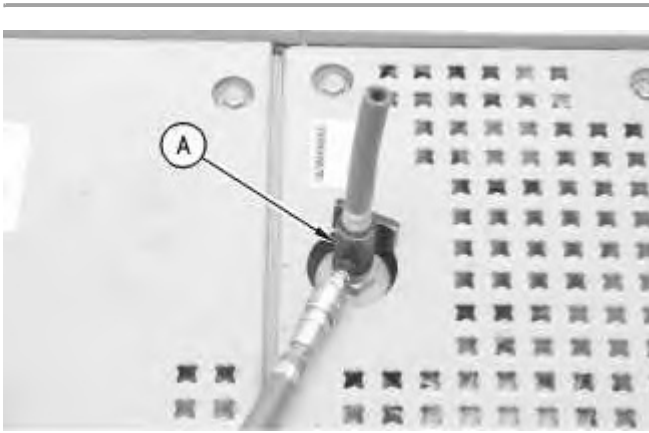

Illustration 2

g00944947

3. Remove the cap from the hydraulic tank. Install Tooling (A) onto the hydraulic tank. Attach an air supply hose to Tooling (A). Apply 276 to 414 kPa (40 to 60 psi) of air. This procedure will pull vacuum on the hydraulic system.

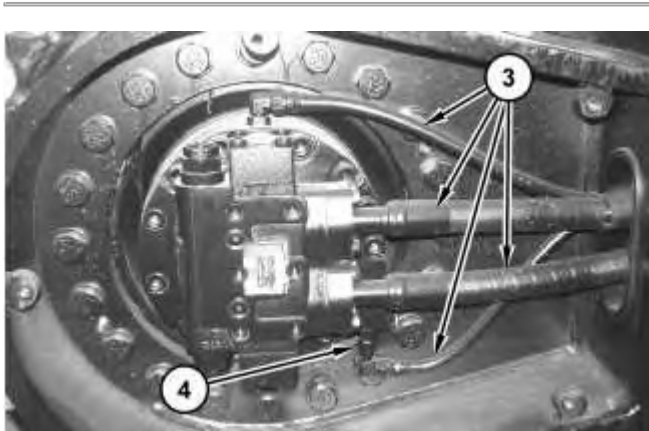

Illustration 3

g01223711

4. Disconnect hose assemblies (3) and remove fitting (4).
-

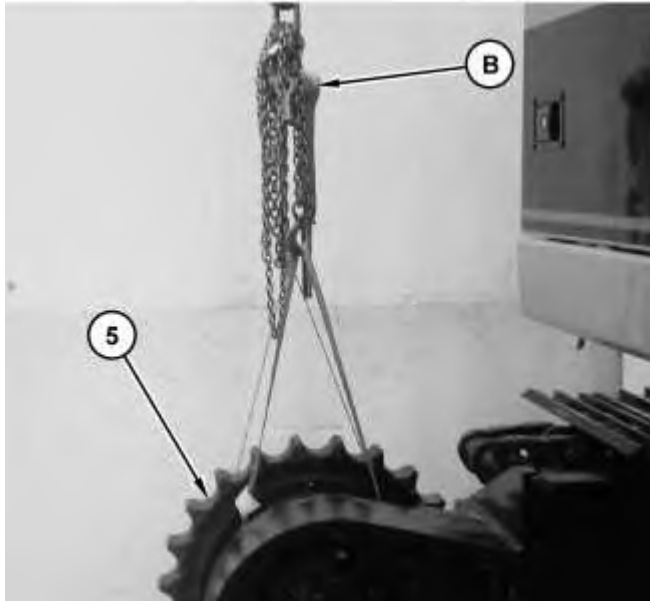

Illustration 4

g01181911

5. Attach Tooling (B) and a suitable lifting device to final drive and travel motor (5). The weight of final drive and travel motor (5) is approximately 860 kg (1896 lb). Put a slight lifting tension on the final drive and travel motor (5).



Illustration 5

g01181912

6. Remove bolts (6).

Note: Mark the orientation of the final drive and travel motor assembly for installation purposes.

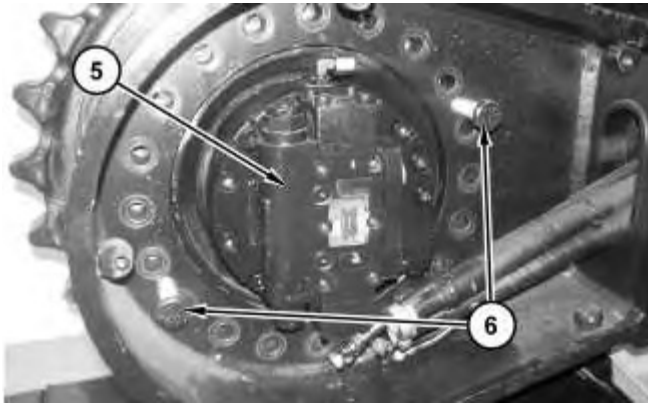

Illustration 6

g01181913

7. Use two bolts (6) in order to remove final drive and travel motor (5).
8. Carefully remove final drive and travel motor (5).
9. Remove bolts (6) from the frame.

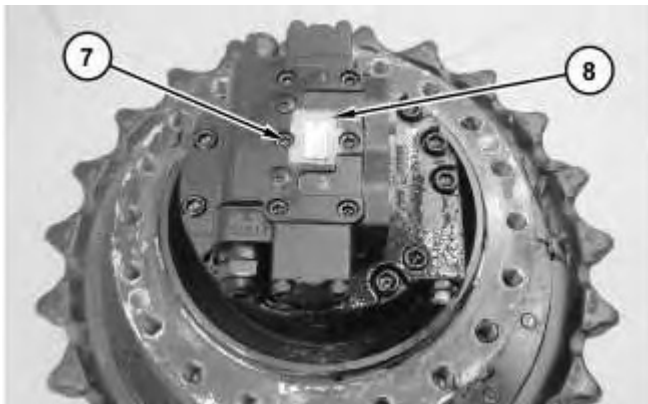

Illustration 7

g01181914

10. Remove bolts (7) and counterbalance valve (8).

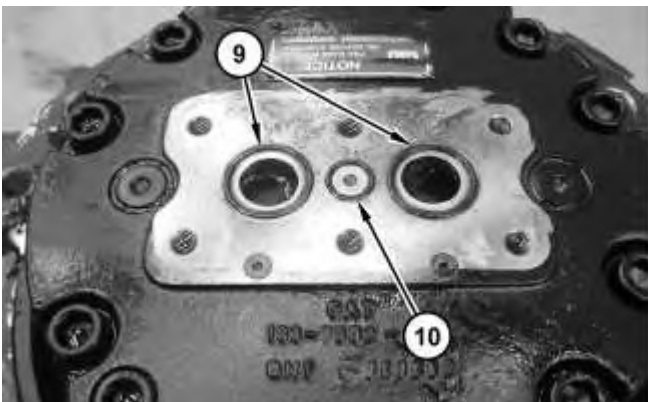

Illustration 8

g01181917

11. Remove O-ring seals (9) and (10).

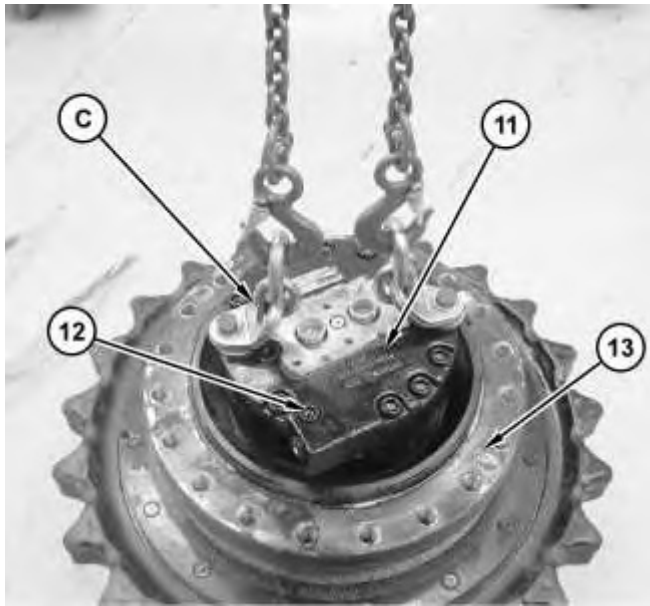

Illustration 9

g01181921

12. Attach Tooling (C) and a suitable lifting device to travel motor (11). The weight of travel motor (11) is approximately 73 kg (160 lb).
13. Remove bolts (12) that mount travel motor (11) to final drive (13). Remove travel motor (11).

[Previous Screen](#)

Product: EXCAVATOR

Model: 330D L EXCAVATOR RAS

Configuration: 330D L & 330D N Hydraulic Excavator RAS00001-UP (MACHINE) POWERED BY C-9 Engine

Disassembly and Assembly

330D, 336D, 336D2, 340D and 340D2 Excavators and 336D MHPU Mobile Hydraulic Power Unit Machine Systems

Media Number -REN8648-30

Publication Date -01/03/2015

Date Updated -15/08/2018

i07188136

Final Drive and Travel Motor - Install

SMCS - 4050-012; 4351-012

Installation Procedure

Table 1

Required Tools			
Tool	Part Number	Part Description	Qty
A	5P-0306	Vacuum Transducer	1
	FT-1115	Vacuum Cap	1
	6V-4142	Fitting	1
	5K-5068	Fitting	1
B	1U-9200	Lever Puller Hoist	1
C	439-3938	Link Bracket	1
D	-	Loctite C5A Copper Anti-Seize	-

Note: Check the O-ring seals for wear or for damage. Replace the O-ring seals, if necessary.

NOTICE

Keep all parts clean from contaminants.

Contaminants may cause rapid wear and shortened component life.

NOTICE

Care must be taken to ensure that fluids are contained during performance of inspection, maintenance, testing, adjusting, and repair of the product. Be prepared to collect the fluid with suitable containers before opening any compartment or disassembling any component containing fluids.

Refer to Special Publication, NENG2500, "Dealer Service Tool Catalog" for tools and supplies suitable to collect and contain fluids on Cat[®] products.

Dispose of all fluids according to local regulations and mandates.

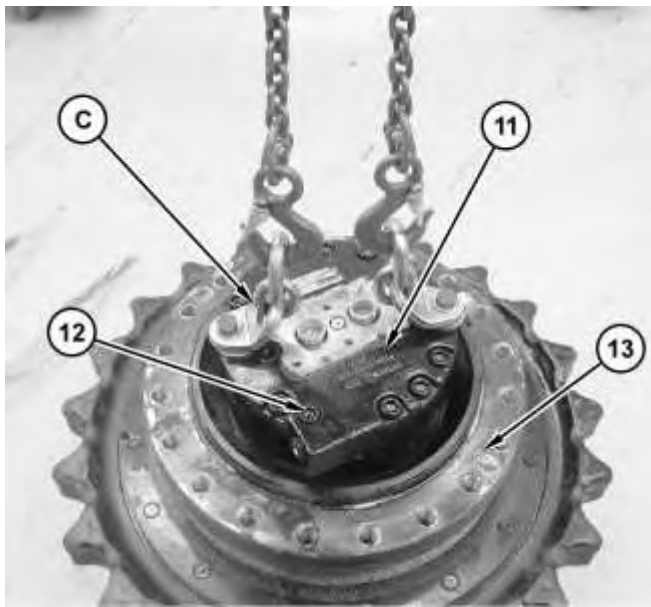

Illustration 1

g01181921

1. Attach Tooling (C) and a suitable lifting device to travel motor (11). The weight of travel motor (11) is approximately 73 kg (160 lb).
 2. Position travel motor (11). Install bolts (12) that mount travel motor (11) to final drive (13).
-

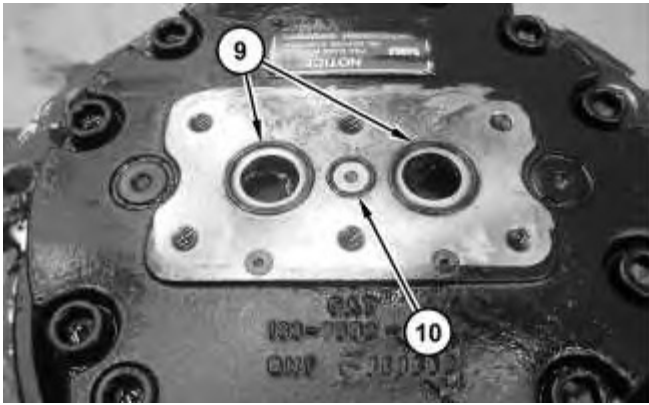

Illustration 2

g01181917

3. Install O-ring seals (10) and (9).

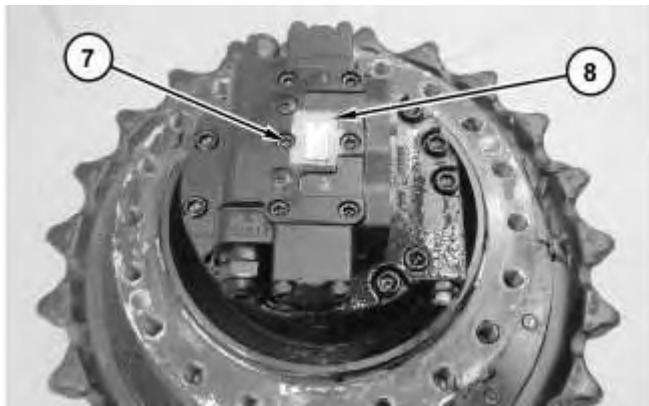

Illustration 3

g01181914

4. Install counterbalance valve (8) and bolts (7).

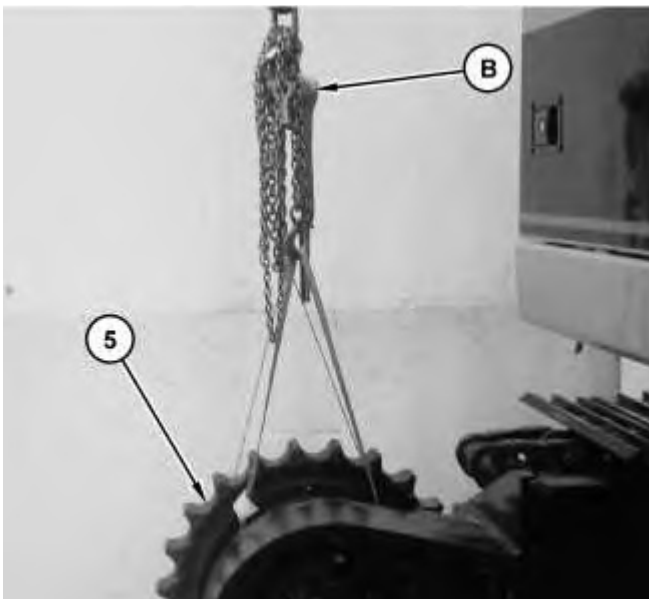

Illustration 4

g01181911

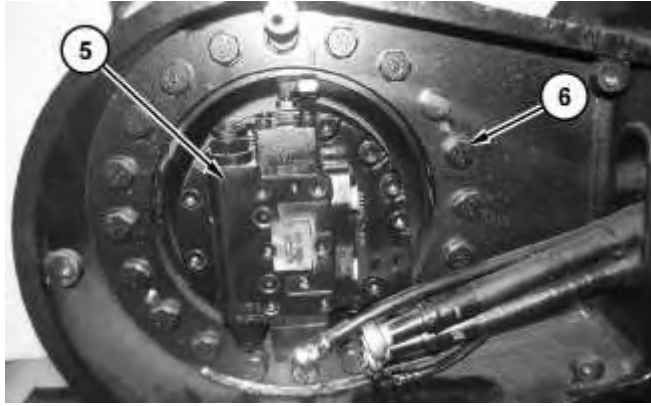

Illustration 5

g01182266

5. Attach Tooling (B) and a suitable lifting device to final drive and travel motor (5). The weight of final drive and travel motor (5) is approximately 860 kg (1896 lb).
6. Carefully position final drive and travel motor (5). Apply Tooling (D) to the threads of bolts (6).
7. Tighten bolts (6) in an alternating sequence to a torque of $250 \pm 25 \text{ N}\cdot\text{m}$ ($184 \pm 18 \text{ lb ft}$). Turn an additional angle of 45 ± 5 degrees. Refer to Service Magazine , M0083843 , "An Improved Bolt Tightening Procedure for the Critical Joints Is Now Used on all Excavators" for more detailed information.

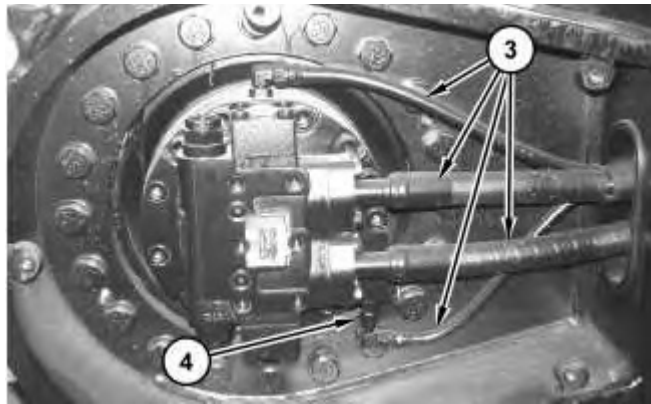

Illustration 6

g01223711

8. Install fitting (4). Connect hose assemblies (3).
-

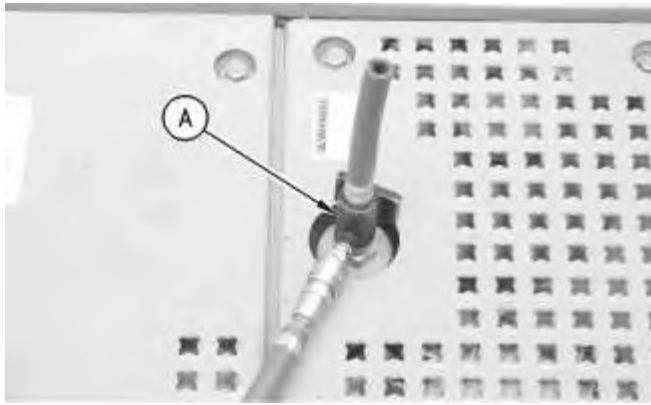

Illustration 7

g00944947

9. Remove Tooling (A). Install the cap onto the hydraulic tank.
10. Fill the hydraulic system. Refer to Operation and Maintenance Manual, "Hydraulic System Oil Level - Check". Refer to Operation and Maintenance Manual, "Lubricant Viscosities and Refill Capacities".



Illustration 8

g01223707

11. Install cover (2) and bolts (1). Tighten bolts (1) to a torque of 130 ± 10 N·m (96 ± 7 lb ft).

[Previous Screen](#)

Product: EXCAVATOR

Model: 330D L EXCAVATOR RAS

Configuration: 330D L & 330D N Hydraulic Excavator RAS00001-UP (MACHINE) POWERED BY C-9 Engine

Disassembly and Assembly

330D, 336D, 336D2, 340D and 340D2 Excavators and 336D MHPU Mobile Hydraulic Power Unit Machine Systems

Media Number -REN8648-30

Publication Date -01/03/2015

Date Updated -15/08/2018

i02434256

Swivel - Remove

SMCS - 5060-011

Removal Procedure

Table 1

Required Tools			
Tool	Part Number	Part Description	Qty
A	FT-2674	Vacuum Cap	1
B	138-7573	Link Bracket	2

Start By:

- a. Release the hydraulic system pressure. Refer to Disassembly and Assembly, "Hydraulic System Pressure - Release".

NOTICE

Care must be taken to ensure that fluids are contained during performance of inspection, maintenance, testing, adjusting, and repair of the product. Be prepared to collect the fluid with suitable containers before opening any compartment or disassembling any component containing fluids.

Refer to Special Publication, NENG2500, "Dealer Service Tool Catalog" for tools and supplies suitable to collect and contain fluids on Cat products.

Dispose of all fluids according to local regulations and mandates.

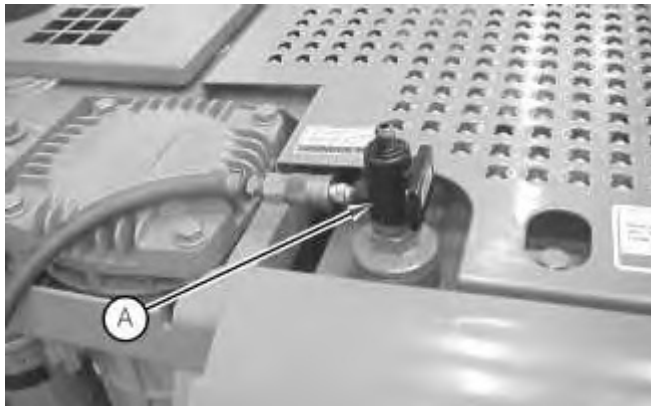

Illustration 1

g01209599

1. Remove the cap from the hydraulic tank. Install Tooling (A) onto the hydraulic tank. Attach an air supply hose to Tooling (A). Apply 276 to 414 kPa (40 to 60 psi) of air. This procedure will pull vacuum on the hydraulic system.

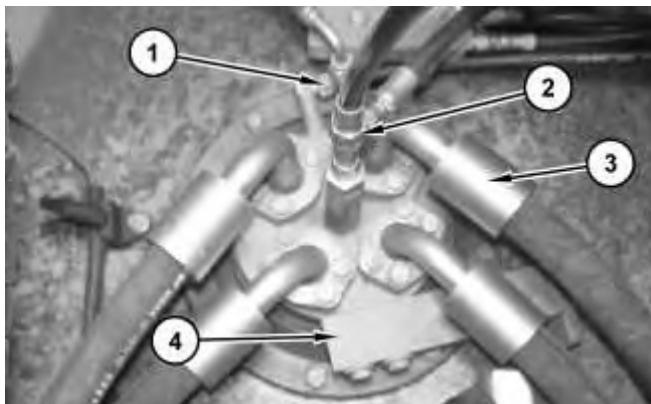

Illustration 2

g01216069

2. Disconnect hose assemblies (1), (2), and (3). Remove support (4).

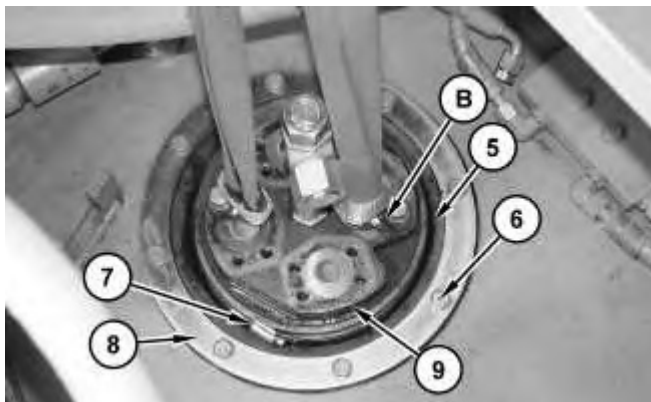

Illustration 3

g01216082

3. Attach Tooling (B) and a suitable lifting device to swivel (9). The weight of swivel (9) is approximately 45 kg (95 lb). Remove bolts (6) and retainer (8). Remove clamp (7) and boot (5).

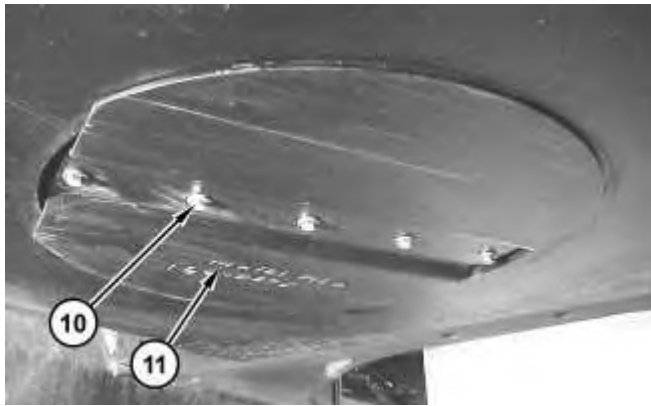

Illustration 4

g01216099

4. Remove bolts (10) and covers (11).

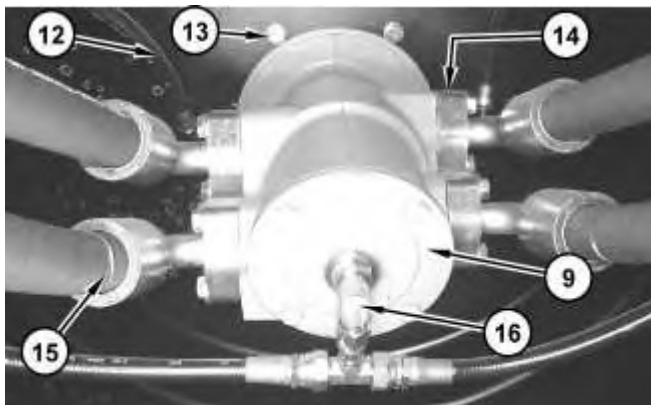

Illustration 5

g01216098

5. Disconnect hose assemblies (15). Disconnect fitting (16). Disconnect hose assemblies (12). Remove fittings (14). Remove bolts (13). Remove swivel (9).

[Previous Screen](#)

Product: EXCAVATOR

Model: 330D L EXCAVATOR RAS

Configuration: 330D L & 330D N Hydraulic Excavator RAS00001-UP (MACHINE) POWERED BY C-9 Engine

Disassembly and Assembly

330D, 336D, 336D2, 340D and 340D2 Excavators and 336D MHPU Mobile Hydraulic Power Unit Machine Systems

Media Number -REN8648-30

Publication Date -01/03/2015

Date Updated -15/08/2018

i02568407

Swivel - Disassemble

SMCS - 5060-015

Disassembly Procedure

Table 1

Required Tools			
Tool	Part Number	Part Description	Qty
A	6V-3822	Bolt	2
	6V-5839	Washer	2
	1P-5546	Crossblock	1
	5P-4168	Step Plate	1
	5F-7366	Screw	1
B	1P-2420	Transmission Repair Stand	1

Start By:

- a. Remove the swivel joint. Refer to Disassembly and Assembly, "Swivel - Remove".

NOTICE

Care must be taken to ensure that fluids are contained during performance of inspection, maintenance, testing, adjusting, and repair of the product. Be prepared to collect the fluid with suitable containers before opening any compartment or disassembling any component containing fluids.

Refer to Special Publication, NENG2500, "Dealer Service Tool Catalog" for tools and supplies suitable to collect and contain fluids on Cat products.

Dispose of all fluids according to local regulations and mandates.

1. Thoroughly clean the outside of the swivel joint prior to disassembly.

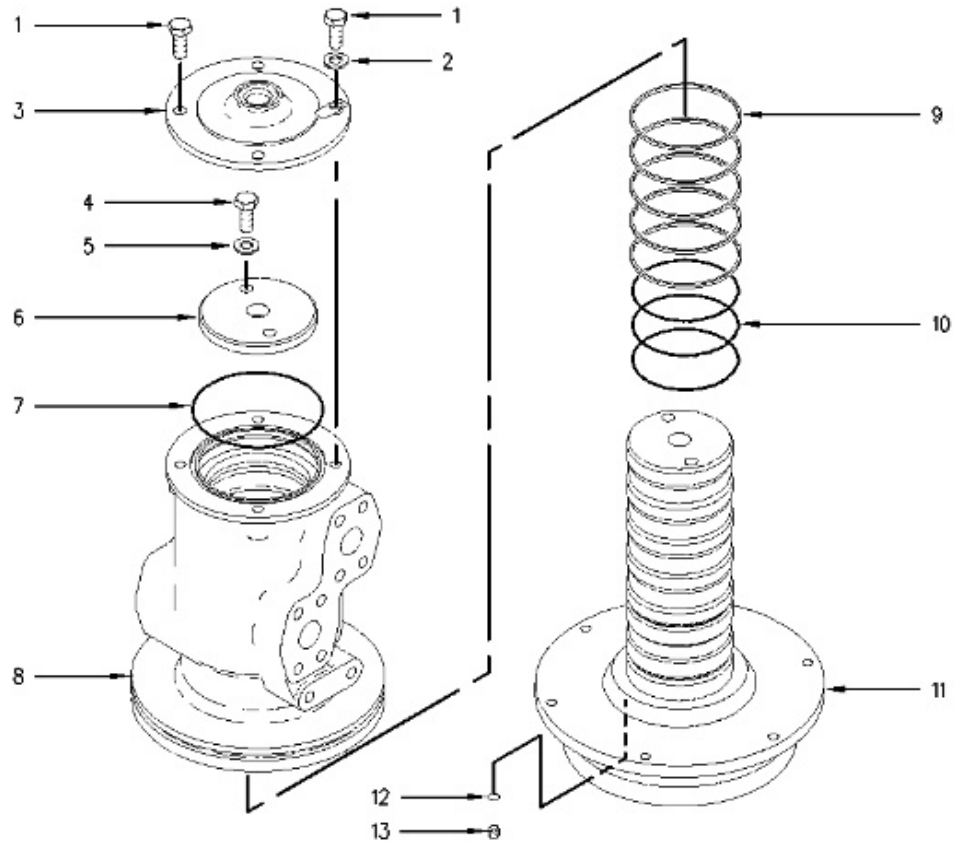

Illustration 1

g00633843



Illustration 2

g00633841

2. Use a suitable lifting device to position the swivel joint onto Tooling (B). Fasten the swivel joint to Tooling (B), as shown. The weight of the swivel joint is approximately 43 kg (95 lb).
3. Remove bolts (1), washers (2), and cover (3) from outside housing (8).
4. Remove O-ring seal (7) from outside housing (8).
5. Remove bolts (4), washers (5), and retainer (6) from rotor (11).

6. Use Tooling (A) in order to separate the outside housing (8) from rotor (11). The weight of outside housing (8) is approximately 20 kg (45 lb). The weight of rotor (11) is approximately 21 kg (46 lb).
7. Remove seals (9) from outside housing (8).
8. Remove O-ring seals (10) from the outside housing (8).
9. Remove plug (13). Remove O-ring seal (12) from plug (13).

[Previous Screen](#)

Product: EXCAVATOR

Model: 330D L EXCAVATOR RAS

Configuration: 330D L & 330D N Hydraulic Excavator RAS00001-UP (MACHINE) POWERED BY C-9 Engine

Disassembly and Assembly

330D, 336D, 336D2, 340D and 340D2 Excavators and 336D MHPU Mobile Hydraulic Power Unit Machine Systems

Media Number -REN8648-30

Publication Date -01/03/2015

Date Updated -15/08/2018

i02426337

Swivel - Assemble

SMCS - 5060-016

Assembly Procedure

Note: Cleanliness is an important factor. Before assembly, thoroughly clean all parts in cleaning fluid. Allow the parts to air dry. Do not use wiping cloths or rags to dry parts. Lint may be deposited on the parts which may cause trouble. Inspect all parts. If any parts are worn or damaged, use new parts for replacement. Dirt and other contaminants can damage the precision component. Perform assembly procedures on a clean work surface. Keep components covered and protected at all times.

Note: Check the O-ring seals, the gaskets, and the seals for wear or for damage. Replace the components, if necessary.

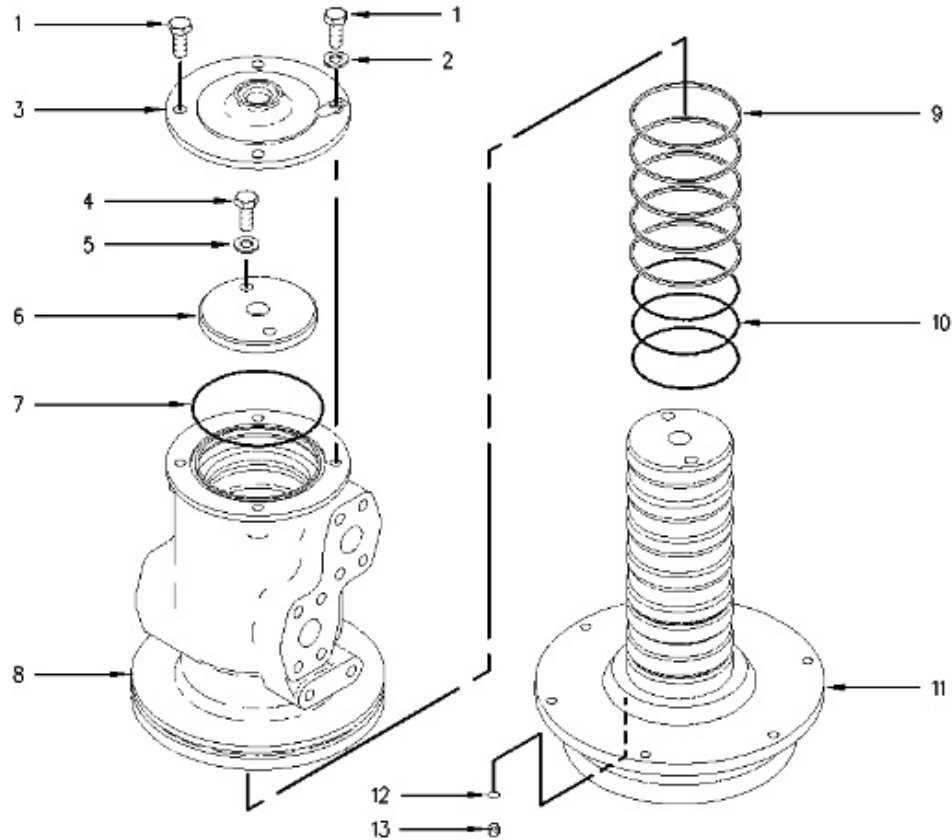

Illustration 1

g00633843

1. Install O-ring seal (12) on plug (13). Apply clean hydraulic oil on the seal. Install plug (13).
2. Install seals (9) and O-ring seals (10) into outside housing (8).
3. Carefully install outside housing (8) over rotor (11).
4. Install retainer (6), washers (5), and bolts (4). This holds the rotor (11) and the outside housing (8) together.
5. Apply clean hydraulic oil on O-ring seal (7). Install the O-ring seal in the outside housing.
6. Install cover (3), washers (2), and bolts (1) that secure the cover.
7. Check the swivel joint for leaks. Plug the drain ports of the inside body. Apply shop air pressure in the top of the swivel joint and check the swivel joint for leaks. The shop air pressure should be between 0.2758 MPa (40 psi) and 0.4137 MPa (60 psi).

End By:

- a. Install the swivel joint. Refer to Disassembly and Assembly, "Swivel - Install".

Previous Screen

Product: EXCAVATOR

Model: 330D L EXCAVATOR RAS

Configuration: 330D L & 330D N Hydraulic Excavator RAS00001-UP (MACHINE) POWERED BY C-9 Engine

Disassembly and Assembly

330D, 336D, 336D2, 340D and 340D2 Excavators and 336D MHPU Mobile Hydraulic Power Unit Machine Systems

Media Number -REN8648-30

Publication Date -01/03/2015

Date Updated -15/08/2018

i02434356

Swivel - Install

SMCS - 5060-012

Installation Procedure

Table 1

Required Tools			
Tool	Part Number	Part Description	Qty
A	FT-2674	Vacuum Cap	1
B	138-7573	Link Bracket	2

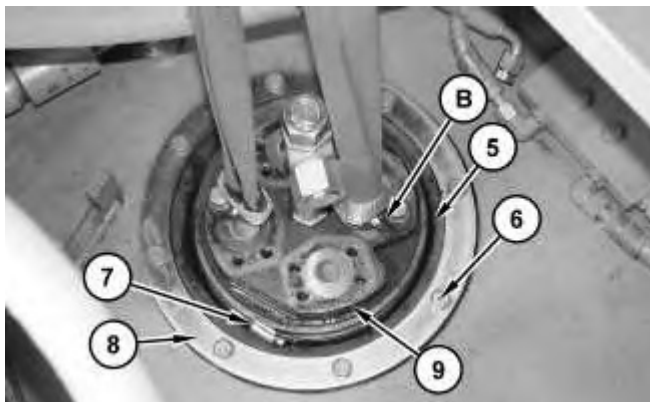

Illustration 1

g01216082

1. Attach Tooling (B) and a suitable lifting device to swivel (9). The weight of swivel (9) is approximately 45 kg (95 lb). Position swivel (9). Install boot (5) and clamp (7). Install retainer (8) and bolts (6).

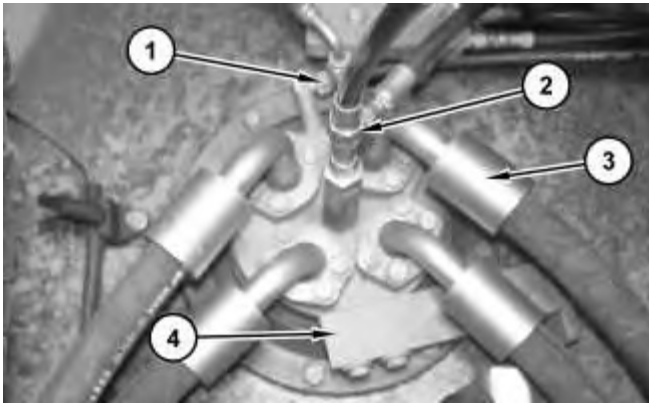

Illustration 2

g01216069

2. Connect hose assemblies (1), (2), and (3). Install support (4).

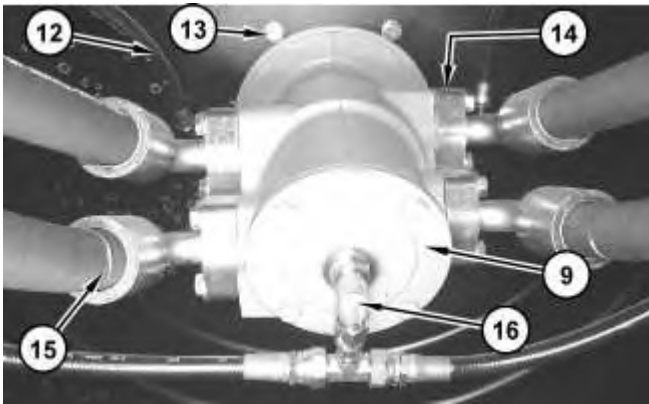

Illustration 3

g01216098

3. Install bolts (13). Install fittings (14). Install fitting (16). Connect hose assemblies (15). Connect hose assemblies (14) and (12) to swivel (9).



Illustration 4

g01216099

4. Install covers (11) and bolts (10).

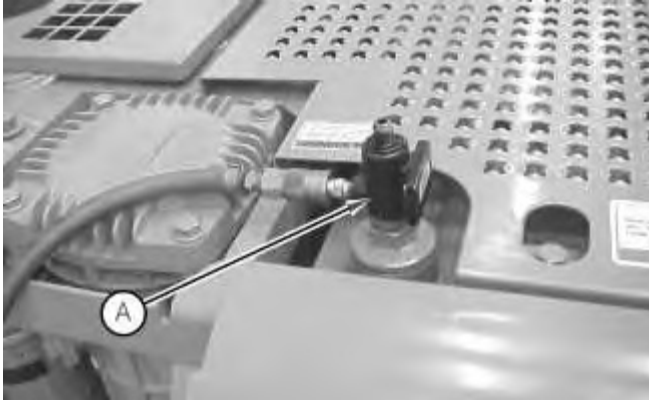

Illustration 5

g01209599

5. Remove Tooling (A).

[Copyright 1993 - 2020 Caterpillar Inc.](#)

[All Rights Reserved.](#)

[Private Network For SIS Licensees.](#)

Mon Aug 3 14:15:34 UTC+0800 2020

[Previous Screen](#)

Product: EXCAVATOR

Model: 330D L EXCAVATOR RAS

Configuration: 330D L & 330D N Hydraulic Excavator RAS00001-UP (MACHINE) POWERED BY C-9 Engine

Disassembly and Assembly

330D, 336D, 336D2, 340D and 340D2 Excavators and 336D MHPU Mobile Hydraulic Power Unit Machine Systems

Media Number -REN8648-30

Publication Date -01/03/2015

Date Updated -15/08/2018

i02434311

Solenoid Valve (Two-Way Flow and One Pump/Two Pump) - Remove

SMCS - 5479-011

Removal Procedure

Table 1

Required Tools			
Tool	Part Number	Part Description	Qty
A	FT-2674	Vacuum Cap	1

Note: Cleanliness is an important factor. Before the disassembly procedure, the exterior of the component should be thoroughly cleaned. This will help to prevent dirt from entering the internal mechanism.

Note: Put identification marks on all lines, on all hoses, on all harness assemblies, and on all tubes for installation purposes. Plug all lines, hoses, and tubes. This helps to prevent fluid loss and this helps to keep contaminants from entering the system.

NOTICE

Care must be taken to ensure that fluids are contained during performance of inspection, maintenance, testing, adjusting, and repair of the product. Be prepared to collect the fluid with suitable containers before opening any compartment or disassembling any component containing fluids.

Refer to Special Publication, NENG2500, "Dealer Service Tool Catalog" for tools and supplies suitable to collect and contain fluids on Cat products.



Suggest:

If the above button click is invalid.

Please download this document

first, and then click the above link

to download the complete manual.

Thank you so much for reading

Dispose of all fluids according to local regulations and mandates.



Personal injury can result from hydraulic oil pressure and hot oil.

Hydraulic oil pressure can remain in the hydraulic system after the engine has been stopped. Serious injury can be caused if this pressure is not released before any service is done on the hydraulic system.

Make sure all of the work tools have been lowered to the ground, and the oil is cool before removing any components or lines. Remove the oil filler cap only when the engine is stopped, and the filler cap is cool enough to touch with your bare hand.



Illustration 1

g00690963

1. Install Tooling (A) onto the hydraulic tank. Attach an air supply hose onto Tooling (A). Apply 276 to 414 kPa (40 to 60 psi) of air. This procedure will pull vacuum on the hydraulic system.



<https://www.ebooklibonline.com>

Hello dear friend!

Thank you very much for reading.

Enter the link into your browser.

The full manual is available for immediate download.

<https://www.ebooklibonline.com>