



Service Repair Manual

Models

330D FM EXCAVATOR

[Previous Screen](#)

Product: EXCAVATOR

Model: 330D FM EXCAVATOR H3K

Configuration: 330D Forest Swing Machine H3K00001-UP (MACHINE) POWERED BY C9 Engine

Disassembly and Assembly 330D Forest Machine Machine Systems

Media Number -KENR5988-00

Publication Date -01/07/2007

Date Updated -03/07/2007

i02785246

Final Drive - Disassemble

SMCS - 4050-015

Disassembly Procedure

Table 1

Required Tools			
Tool	Part Number	Part Description	Qty
A	138-7576	Link Bracket	2
B	1P-1855	Retaining Ring Pliers	1
C	1P-1862	Retaining Ring Pliers	1
D	5P-5197	Retaining Ring Pliers	1
E	1P-2321	Puller Assembly ⁽¹⁾	1
F	1P-0520	Drive Group	1
G	2P-8312	Retaining Ring Pliers	1
H	138-7574	Link Bracket	3
	1P-5546	Crossbar	1
	5F-7366	Screw	1
	1P-0523	Drive Plate	1
	9S-8546	Seal Installer	1
J	6V-3532	Bolt	2
	8T-3282	Washer	2
K	1U-8758	Retaining Ring Pliers	1

	1P-0074	Slide Hammer Puller Gp	1
L	1P-0069	Head	1
	2P-2312	Puller leg	3
M	1P-7407	Eyebolt	2
N	199-6557	Spanner socket	1
P	4C-8359	Eyebolt	2
Q	127-8458	Final Drive Bench Ar	1
QQ	127-8467	Reaction Plate ⁽²⁾	
R	127-8468	Reaction Bar As	1
S	3S-6224	Electric Hydraulic Pump	1
	8T-0820	Pressure Gauge	1
	3B-7722	Bushing	2
	1P-2376	Coupler Assembly	2
	1P-2377	Plug	2
	8F-0024	Hose Assembly	2
T	154-6182	Forcing Bolt	2

⁽¹⁾ Use **6C-7887** Leg on the two gears that are removed in Step 22.

⁽²⁾ Part of Tooling (Q)

Start By:

- a. Remove the final drive. Refer to Disassembly and Assembly, "Final Drive - Remove".
1. Thoroughly clean the outside of the final drive and travel motor prior to disassembly.

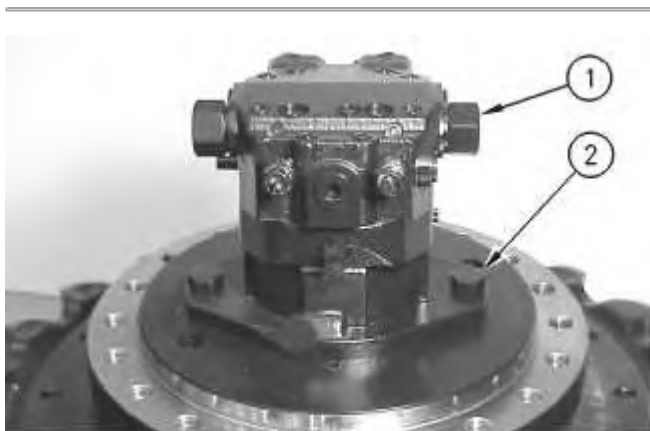

Illustration 1

g00659659

2. Remove bolts (2) that hold travel motor (1) to the final drive.

<https://www.ebooklibonline.com>

Hello dear friend!

Thank you very much for reading.

Enter the link into your browser.

The full manual is available for immediate download.

<https://www.ebooklibonline.com>



Illustration 2

g00659674

3. Fasten two suitable lifting straps and a suitable lifting device to travel motor (1). The weight of travel motor (1) is approximately 54 kg (120 lb). Carefully remove travel motor (1) from the final drive.



Illustration 3

g00676009

4. Remove O-ring seal (3) from the travel motor.



Illustration 4

g00659679

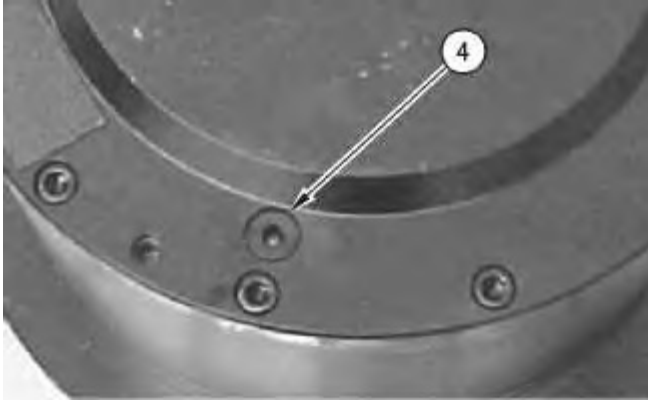

Illustration 5

g00659682

5. Fasten Tooling (A) and a suitable lifting device to the final drive, and turn the final drive on the side. The weight of the final drive is 500 kg (1100 lb).
6. Remove plug (4).

NOTICE

Care must be taken to ensure that fluids are contained during performance of inspection, maintenance, testing, adjusting, and repair of the product. Be prepared to collect the fluid with suitable containers before opening any compartment or disassembling any component containing fluids.

Refer to Special Publication, NENG2500, "Dealer Service Tool Catalog" for tools and supplies suitable to collect and contain fluids on Cat products.

Dispose of all fluids according to local regulations and mandates.

7. Drain the oil from the final drive into a suitable container for storage or disposal. Refer to Operation and Maintenance Manual, "Capacities (Refill)" for the capacity. Refer to Operation and Maintenance Manual, "Final Drive Oil - Change" for the proper procedure.
 8. Reinstall plug (4).
-



Illustration 6

g00659729

9. Position the final drive onto suitable blocking, as shown.
10. Remove the sprocket bolts (5) from final drive sprocket (6).



Illustration 7

g00659738

11. Use a suitable lifting device to remove final drive sprocket (6). If necessary, use a soft faced hammer in order to unseat the sprocket.
12. The weight of the final drive sprocket is 91 kg (200 lb).



Illustration 8

g00659746

13. Remove bolts (7) that hold cover (8) in place.

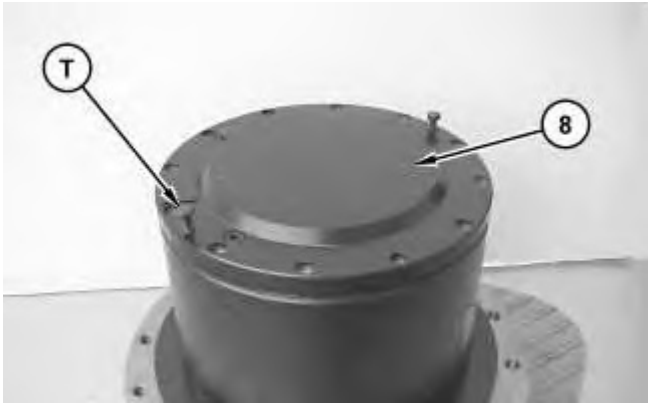

Illustration 9

g01391477

14. Use Tooling (T) to elevate cover (8). This will allow enough clearance for your fingers in order to lift cover (8) off the final drive.
15. Remove cover (8).
16. If necessary, remove the spacer (Not Shown) from cover (8).

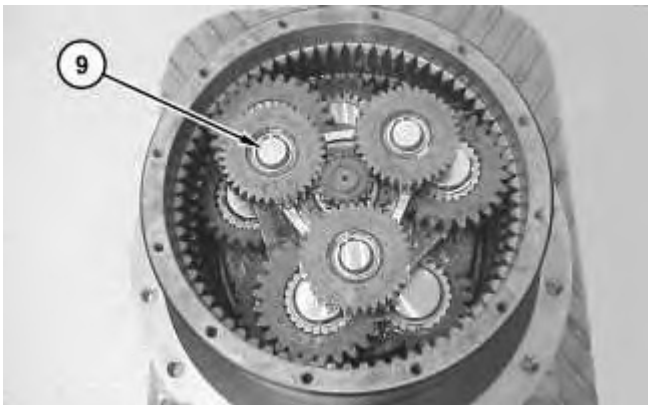

Illustration 10

g01391490

17. Remove carrier assembly (9).
 18. Disassemble carrier assembly (9), as follows:
-

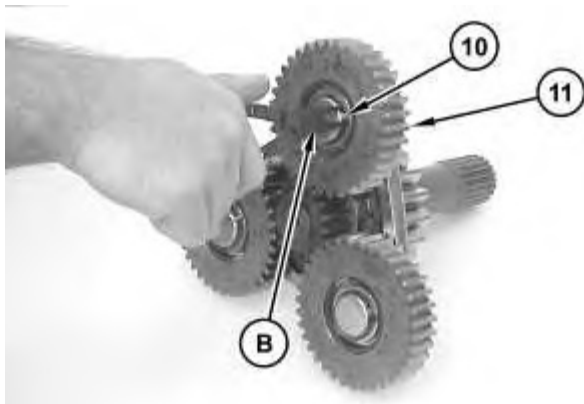

Illustration 11

g01391499

- a. Use Tooling (B) to remove retaining ring (10).

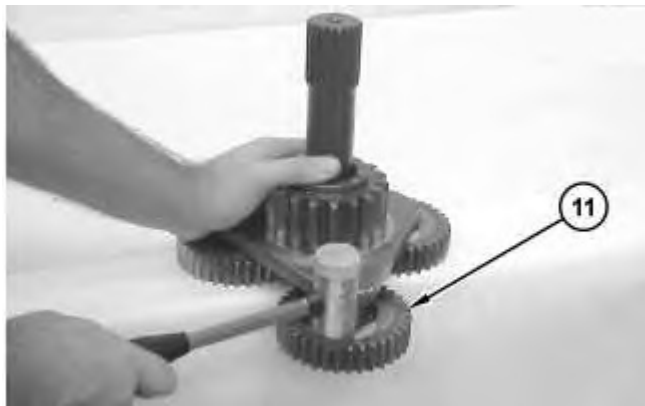

Illustration 12

g01391503

- b. Use a soft faced hammer in order to remove planetary gear assembly (11).

Note: Rotate the planetary gear assembly so that the gear assembly comes off perpendicular to the carrier shaft.

- c. Disassemble planetary gear assembly (11), as follows.



Illustration 13

g01391501

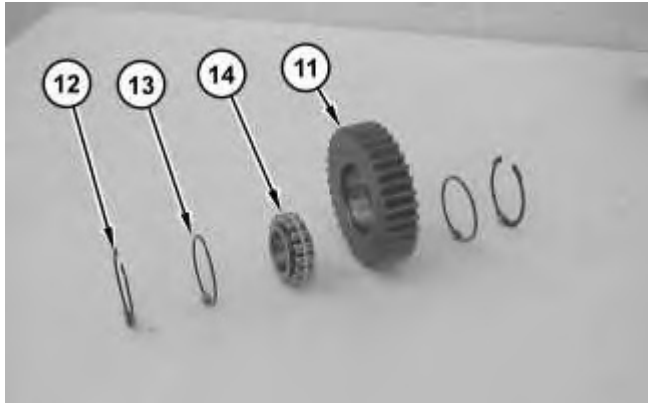

Illustration 14

g01391500

- d. Use Tooling (C) to remove the second retaining ring (12).

Note: When you remove the bearing assembly, the rollers will fall out of the bearing race. Put a rubber band around the bearing rollers as you remove the bearing assembly.

- e. Remove two rings (13), and bearing (13) from planetary gear assembly (11).
f. Repeat Steps 18.a through 18.e for the other two planetary gears.

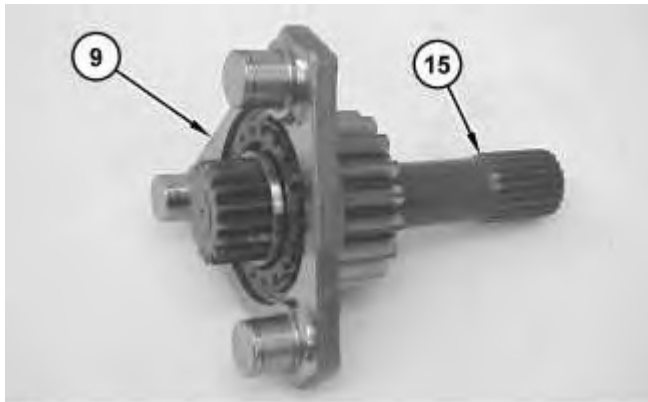
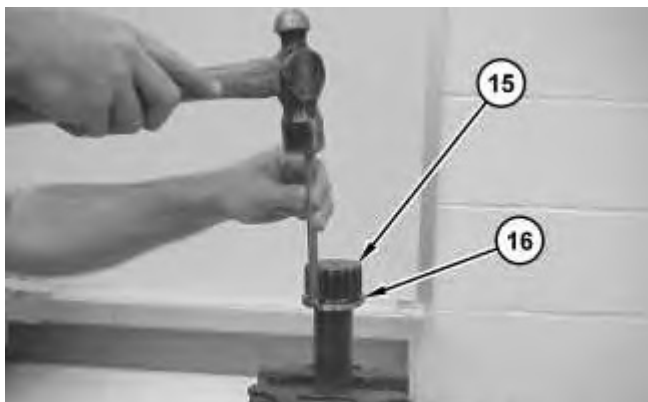

Illustration 15

g01391513

- g. Remove center shaft (15) from carrier assembly (9).



- h. Use a hammer and a punch to remove washer (16) from center shaft (15).

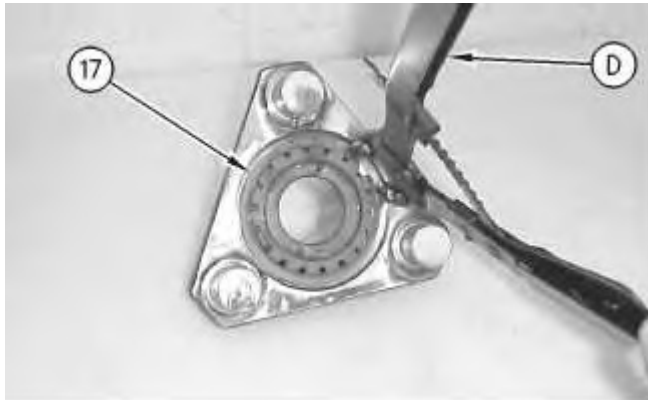

Illustration 17

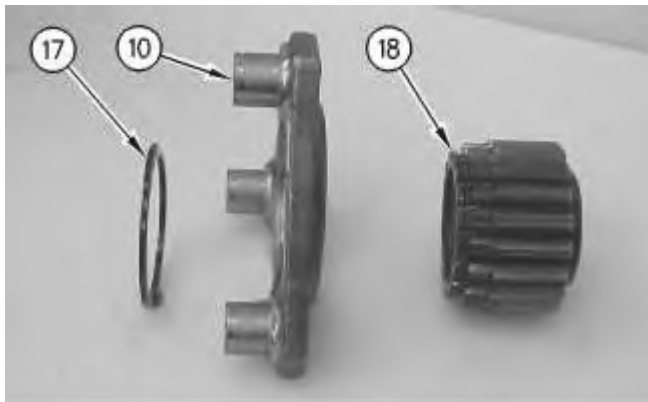

Illustration 18

- i. Use Tooling (D) in order to remove retaining ring (17).
- j. Remove sun gear (18) from carrier assembly (10).



Illustration 19

19. Remove carrier assembly (19).

20. Disassemble carrier assembly (19), as follows:

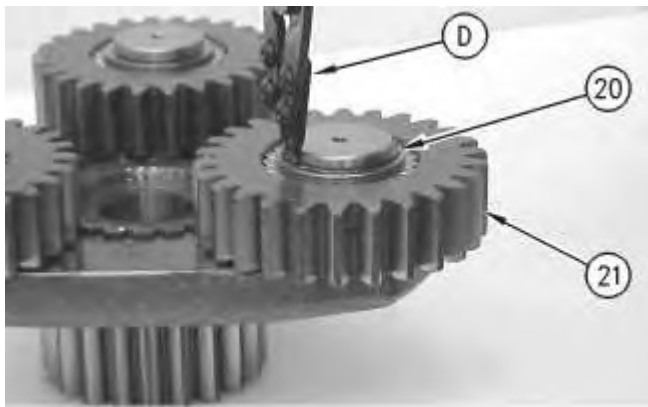

Illustration 20

g00659873

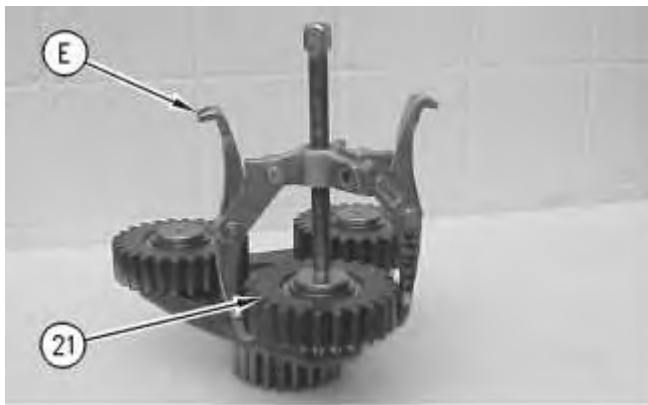

Illustration 21

g00659879

a. Use Tooling (D) to remove retaining ring (20).

b. Use Tooling (E) in order to remove planetary gear assembly (21).

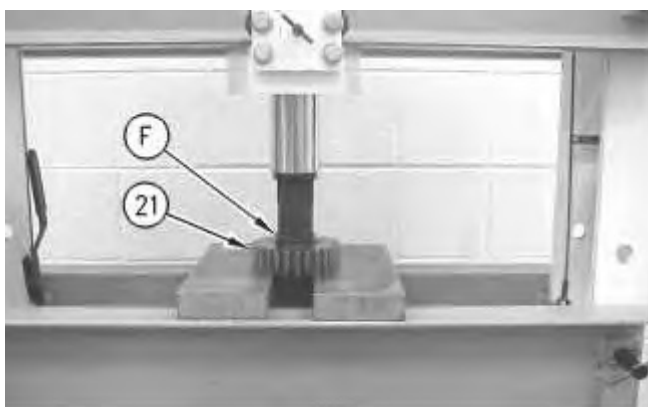

Illustration 22

g00659889

- c. Use Tooling (F) and a suitable press in order to drive the bearing assembly out of planetary gear (21).

Note: This is only one method for removing the bearing. You may also cut the bearing. Make sure that you catch the rollers, while you drive the bearing assembly out of planetary gear (21).

- d. Repeat Steps 20.a through 20.c for the other two planetary gear assemblies.

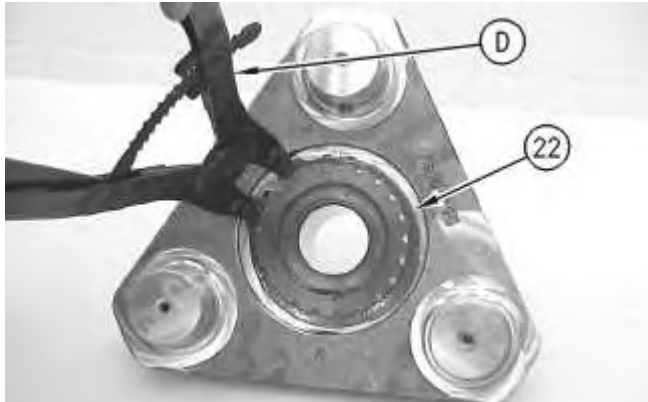

Illustration 23

g00660095

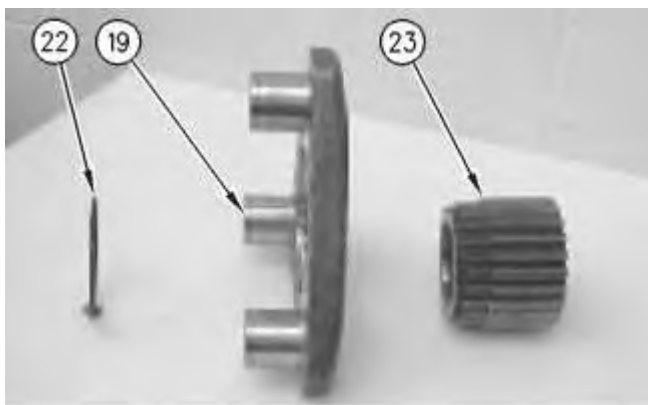

Illustration 24

g00660100

- e. Use Tooling (D) in order to remove retaining ring (22).
- f. Remove sun gear (23) from carrier assembly (19).
-

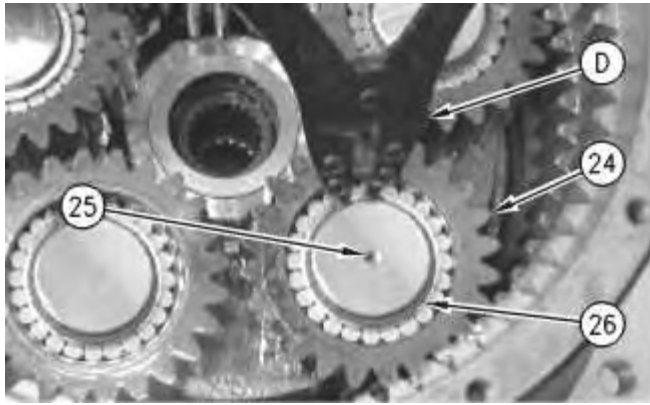

Illustration 25

g00660105

21. Use Tooling (D) in order to remove two retaining rings (26) from two of the planetary gear assemblies (24) from carrier assembly (25).

Note: There are two sets of bearing rollers for each planetary gear assembly. The bearing rollers for the lower bearing assembly will fall after the planetary gear assembly is removed.

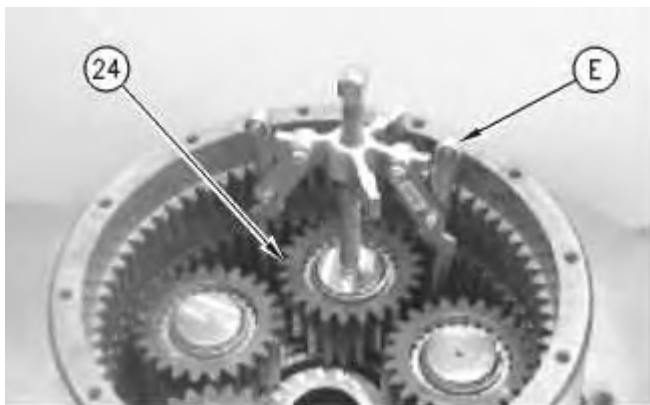

Illustration 26

g00660136

22. Use Tooling (E) in order to remove two planetary gear assemblies (24).

Note: Two planetary gear assemblies (24) are removed in order to access the retaining ring that holds the carrier assembly (25) to the motor housing.

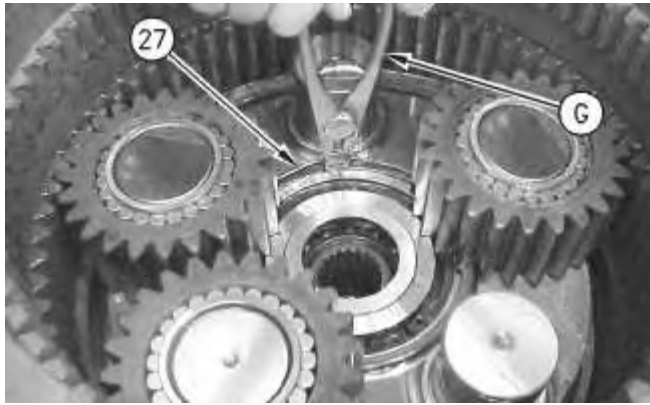

Illustration 27

g00660143

23. Use Tooling (G) in order to remove retaining ring (27).

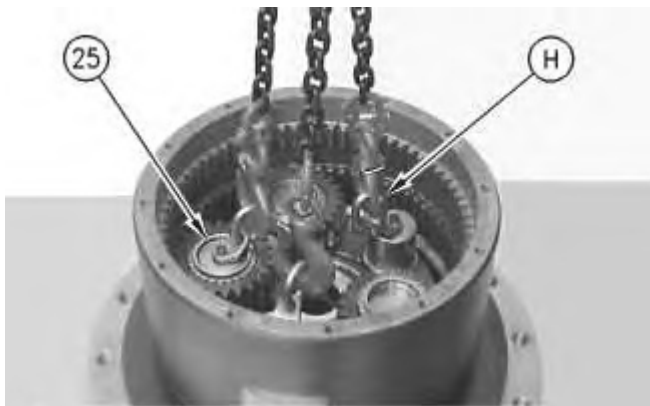

Illustration 28

g00660173

24. Use Tooling (H) and a suitable lifting device to remove carrier assembly (25).
25. Disassemble carrier assembly (25), as follows:



Illustration 29

g00765592

- a. Use Tooling (E) to remove bearing race (28) from the two shafts of carrier assembly (25).

- b. Use Tooling (D) to remove three retaining rings (26) from the three remaining planetary gear assemblies.
- c. Use Tooling (E) to remove planetary gear assemblies from the carrier assembly.
- d. Use Tooling (E) to remove the other three bearing races from the carrier assembly.

Note: Refer to Illustration 26 for the location of planetary gear assemblies (24).

- e. Disassemble planetary gear assemblies (24), as follows.

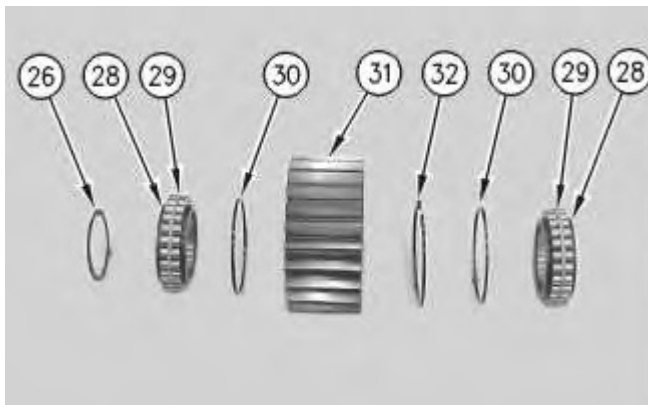

Illustration 30

g00660181

- f. Remove bearing rollers (29), two bearing races (28), two rings (30), and retaining ring (32) from planetary gear (31).

Note: Place a rubber band around the bearing rollers as you remove the bearings.

- 26. Attach a suitable lifting device to the final drive, and turn the final drive over 180 degrees.

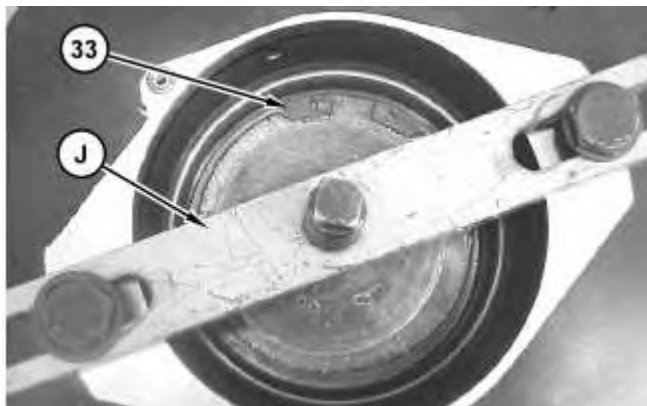

Illustration 31

g01393288

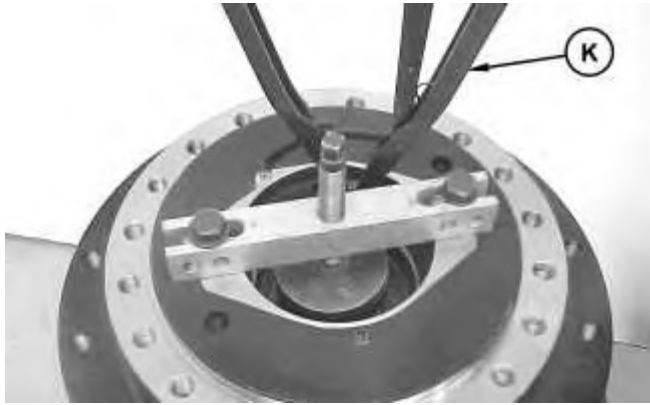

Illustration 32

g01393292

! WARNING

Sudden release of spring force can cause injury.

To prevent the possibility of injury, follow the procedure to relieve the spring pressure.

27. Tighten Tooling (J) in order to relieve the spring pressure.
28. Use Tooling (K) in order to remove retaining ring (33).
29. Slowly release Tooling (J). Remove Tooling (J).



Illustration 33

g00660226

30. Remove plate (34).
31. Remove plug (35).

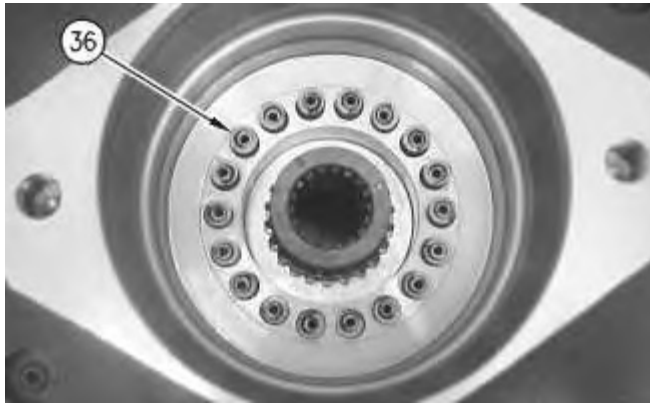

Illustration 34

g00660233

32. Remove springs (36).

Note: There is an inner spring and a outer spring in each spring set.

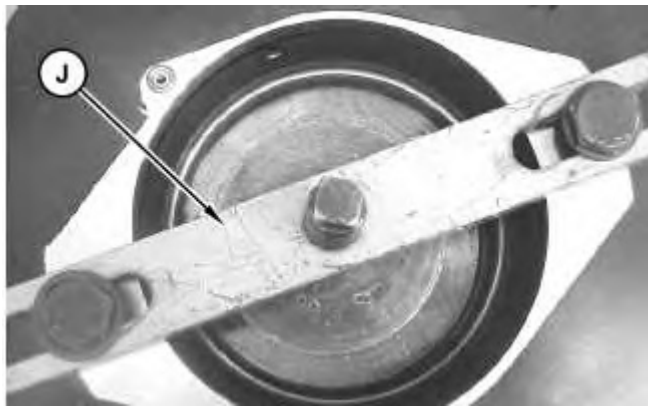

Illustration 35

g01393295

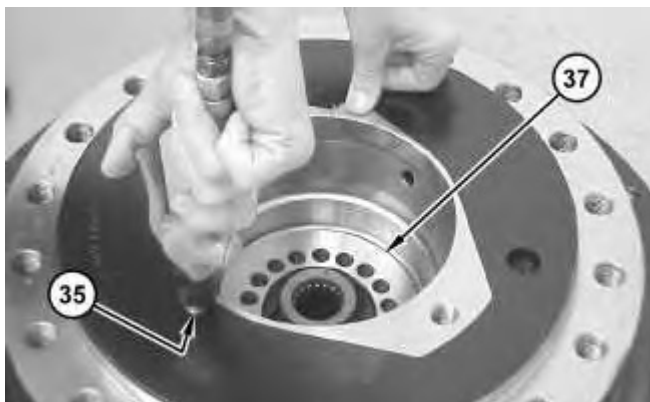

Illustration 36

g01393340

33. Loosely install Tooling (J) so that piston (37) can vertically travel during the application of air pressure. Apply air pressure through the port of plug (35). Hold a finger over the port directly across plug (35) while you inject the air. This will unseat the brake piston (37).

34. Remove brake piston (37).



Illustration 37

g00660245

35. Remove two backup rings (38) and O-ring seal (39) from the piston.

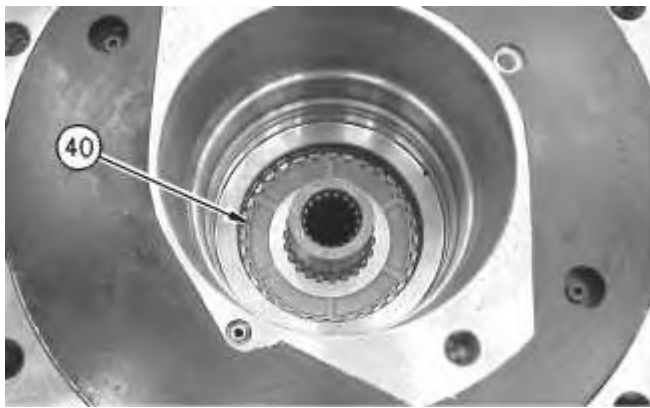

Illustration 38

g00660451

36. Attach a suitable lifting device to the final drive, and turn the final drive over 180 degrees in order for the discs and plates to fall out of the motor housing.

37. Remove discs and plates (40) from the motor housing.

Note: Note the orientation of the discs and the plates for installation purposes.



38. Use Tooling (L) to remove washer (41).

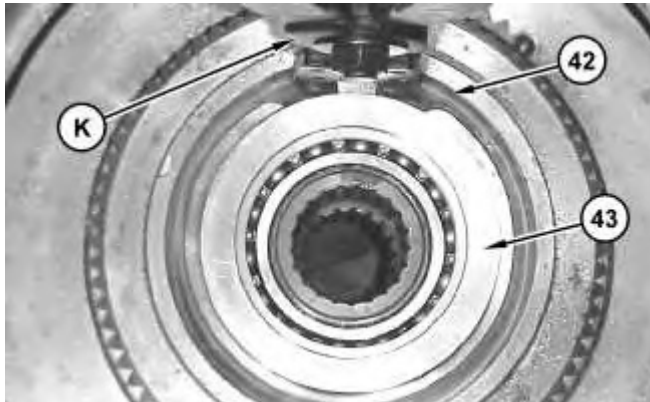

Illustration 40

39. Use Tooling (K) to remove retaining ring (42).

Note: Tap on plate (43) in order to relieve the pressure that is on retaining ring (42).

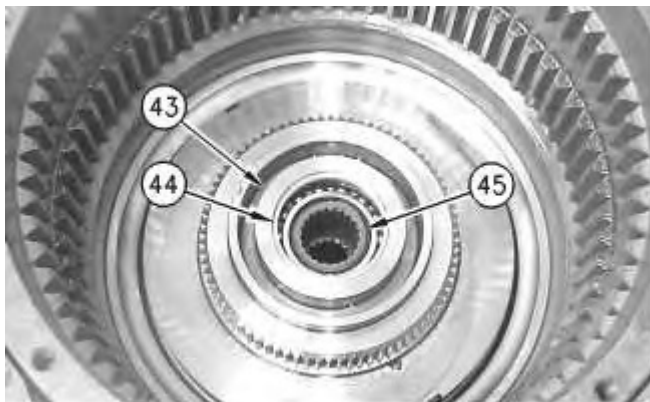
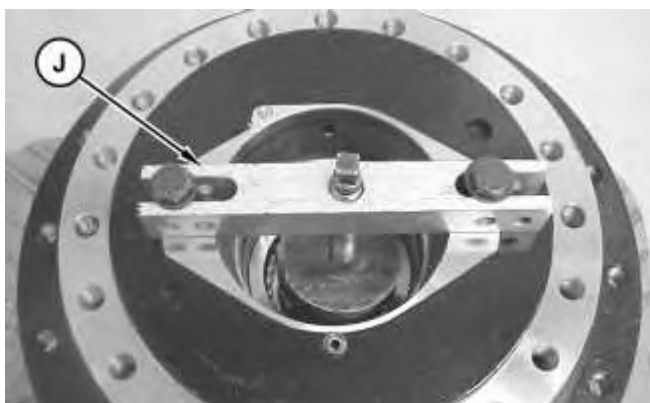

Illustration 41



40. Attach a suitable lifting device to the final drive, and turn the final drive over 180 degrees, as shown.
41. Use Tooling (J) in order to remove coupling shaft (45), bearing (44), and plate (43).

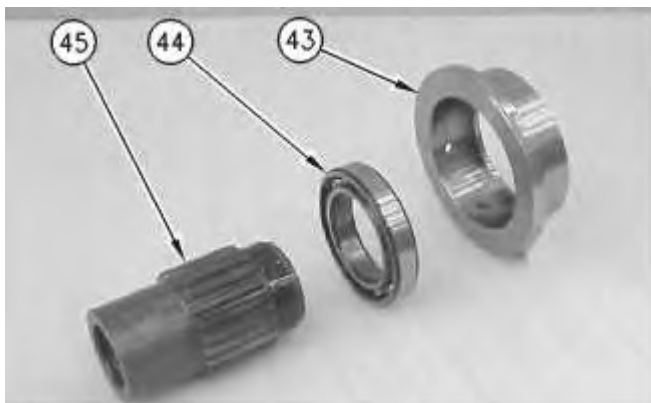

Illustration 43

g00660550

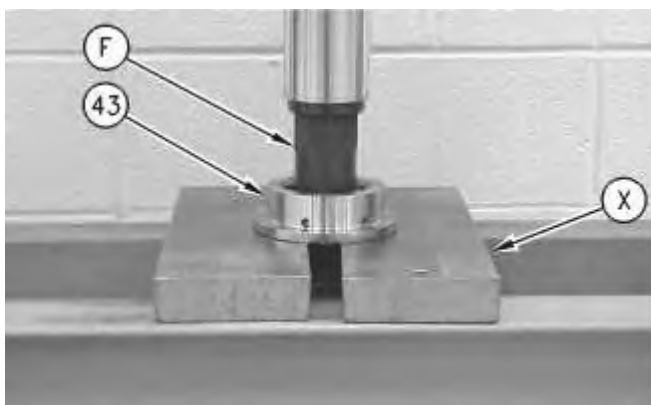

Illustration 44

g00660508

42. Disassemble coupling shaft (45), bearing (44), and plate (43), as follows.
 - a. Use Tooling (F) and a suitable press in order to push the coupling shaft (45) through bearing (44) and plate (43).

Note: Bearing (44) will stop once the bearing makes contact with the Plates (X).



Illustration 45

g00660671

Note: Spread Plates (X) wide enough so that bearing (44) can be removed from plate (43).

- b. Use Tooling (F) and a suitable press in order to push bearing (44) out of plate (43).



Illustration 46

g00660479

(U) Notches for Tooling (N)

43. Drill out two dowels (47) in order to remove locknut (46).

127-8458 Final Drive Disassembly and Assembly Bench

Note: The following procedure is for using the final drive disassembly and assembly **127-8458** Bench.

Note: Tooling (QQ) is part of the **127-8458** Final Drive Bench Ar.

Reference: Refer to the Tool Operating Manual, NEHS0673 for further procedures concerning **127-8458** Bench.

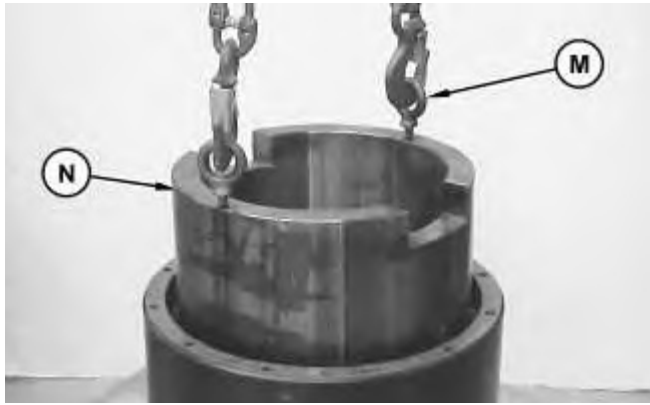

Illustration 47

g01393415

1. Fasten Tooling (M) and a suitable lifting device to Tooling (N).

Note: Refer to Illustration 46 for the location of notches (U) in nut (46).

2. Lower Tooling (N) into the final drive. Make sure that the notches in nut (46) are aligned with the keys on Tooling (N). The approximate weight of Tooling (N) is 45 kg (100 lb).



Illustration 48

g01393436

3. Fasten Tooling (P) and a suitable lifting device to the final drive. Keep the suitable lifting device attached.
4. Position the final drive on Tooling (QQ).

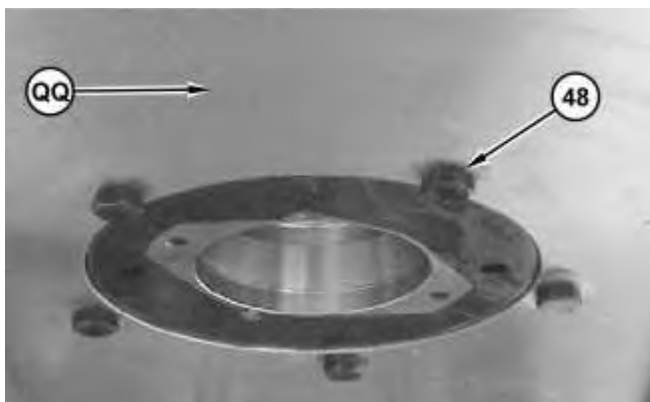

5. Raise the final drive and Tooling (QQ) into the air so that you can bolt the final drive and Tooling (QQ) together with bolts (48).

Note: Place blocks under Tooling (QQ) while you tighten bolts (48).

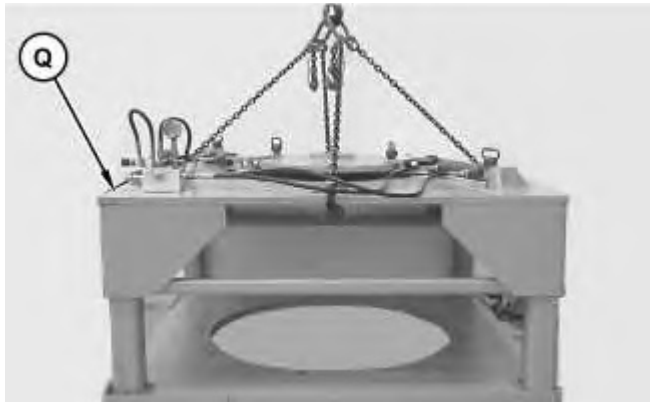

Illustration 50

g01393457

6. Remove the suitable lifting device from Tooling (P) and attach four chains and a suitable lifting device to the upper half of Tooling (Q).
7. Remove the upper half of Tooling (Q). The weight of the upper half is 816 kg (1800 lb).

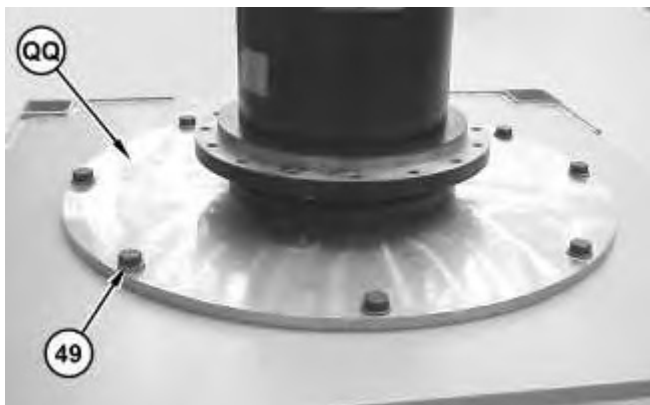

Illustration 51

g01393489

8. Install Tooling (P) and a suitable lifting device to Tooling (QQ). Place Tooling (QQ) and the final drive onto the lower half of Tooling (Q). The weight of the final drive, Tooling (QQ), and Tooling (N) is 522 kg (1150 lb).
 9. Fasten the final drive onto the lower half of Tooling (Q). Use eight 1 - 8THDX3.5 inch bolts (49) and eight 1 - 8THD nuts with washers.
 10. Remove Tooling (P) and the suitable lifting device.
-



Illustration 52

g01393962

11. Place Tooling (R) into the final drive.
12. Fasten a suitable lifting device to the upper half of Tooling (Q) and install the upper half of Tooling (Q) to the lower half of Tooling (Q). Pin the two halves together.

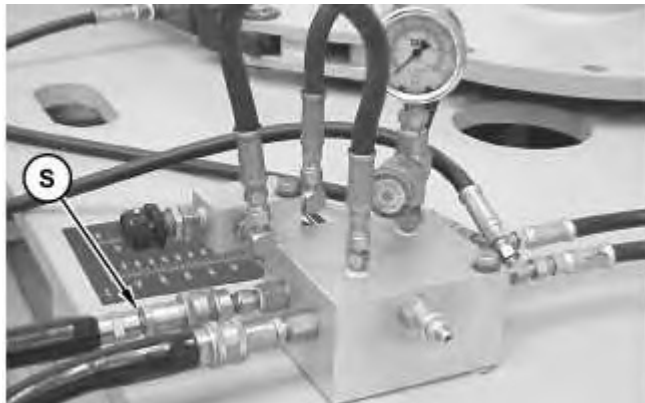
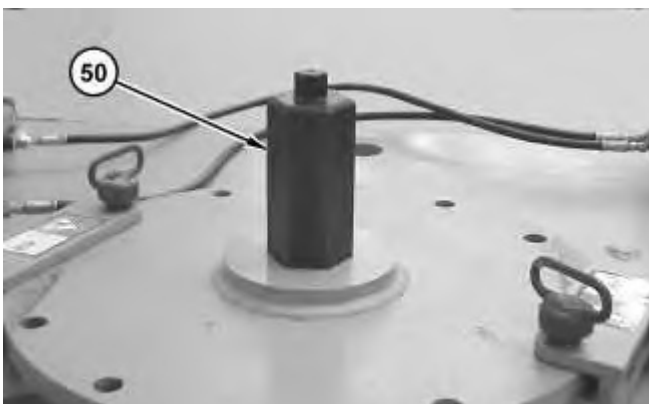

Illustration 53

g01394025

13. Attach Tooling (S) to the pressure reducing valve manifold, as shown.
14. Set the torque level for the bench to 2000 psi (14500 lb ft). Do not exceed this pressure.

Reference: Refer to the Tool Operating Manual, NEHS0673 for setting the torque level.



(50) 128-4075 Shaft As

15. Place hex shaft (50) through the bench and into Tooling (R).
16. Remove locknut (46). The breakaway torque will vary. The nut will loosen usually at 1400 psi (10750 lb ft).
17. Fasten a suitable lifting device to the upper half of Tooling (Q).
18. Remove the upper half of Tooling (Q).

Disassembly Procedure for the Main Housing and the Motor Housing

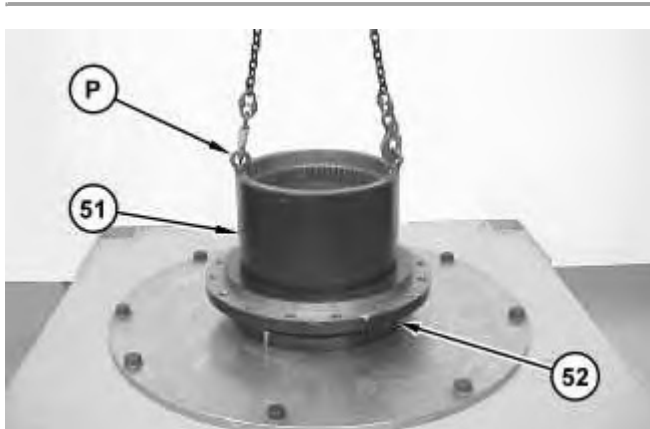

Illustration 55

g01394031

1. Fasten Tooling (P) and a suitable lifting device to main housing (51), as shown.
2. Separate main housing (51) from motor housing (52). The weight of main housing (51) is approximately 204 kg (450 lb).

Note: Two outer races and one roller bearing will be removed with the main housing. The other roller bearing and the two Duo-cone seal kits will remain with the motor housing.

3. Disassemble motor housing (52), as follows.

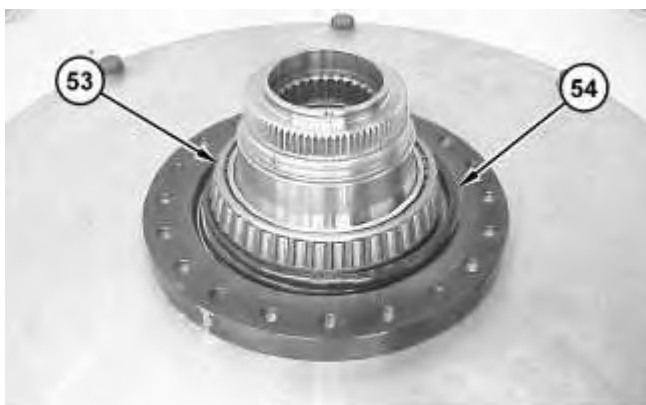

- a. Remove bearing cone (53) from the motor housing.
- b. Remove the Duo-Cone seal kit (54) from the motor housing.

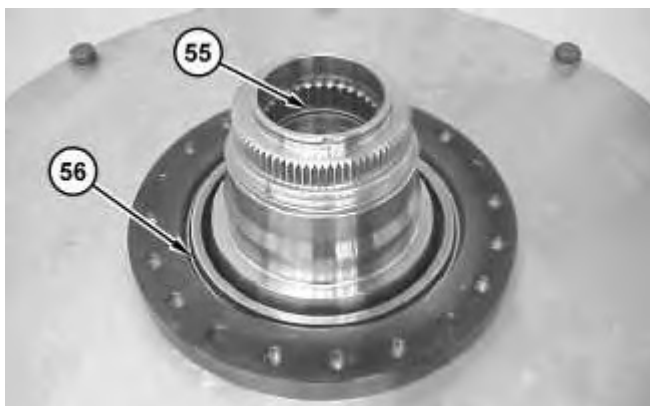

Illustration 57

- c. Remove the two backup rings and O-ring seal (55) from the motor housing.
 - d. Remove the other Duo-Cone seal kit (56) from the motor housing.
4. Disassemble main housing (51), as follows.

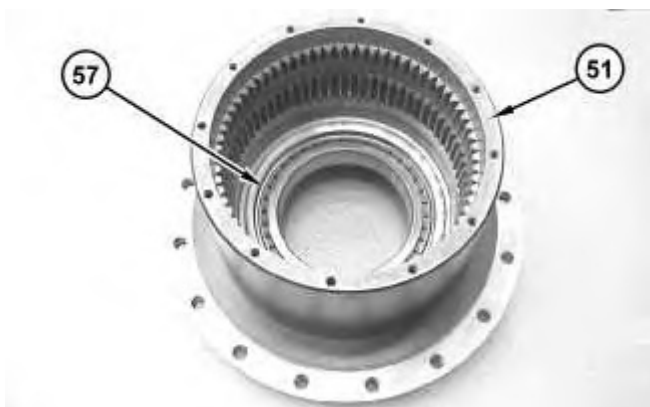

Illustration 58

- a. Remove bearing cone (57) from main housing (51).
-



Suggest:

If the above button click is invalid.

Please download this document

first, and then click the above link

to download the complete manual.

Thank you so much for reading

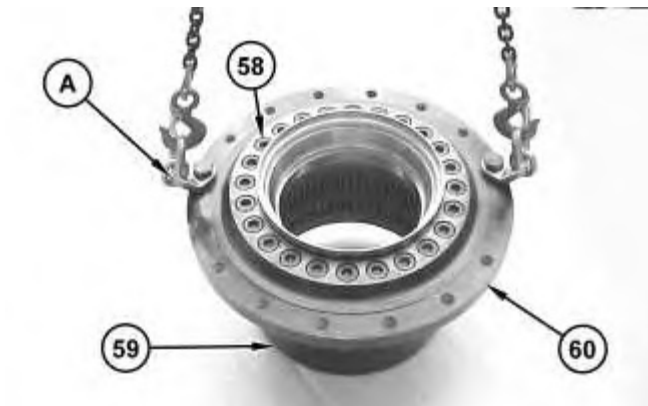

Illustration 59

g01394231

- b. Turn main housing (51) over 180 degrees, as shown.
- c. Remove bolts (58).
- d. Install Tooling (A) and a suitable lifting device to housing (60).
- e. Separate housing (60) from ring gear (59).



Illustration 60

g01394318

- f. Remove bearing cup (61) with a brass punch and a hammer.
- g. Rotate housing (60) over 180 degrees.

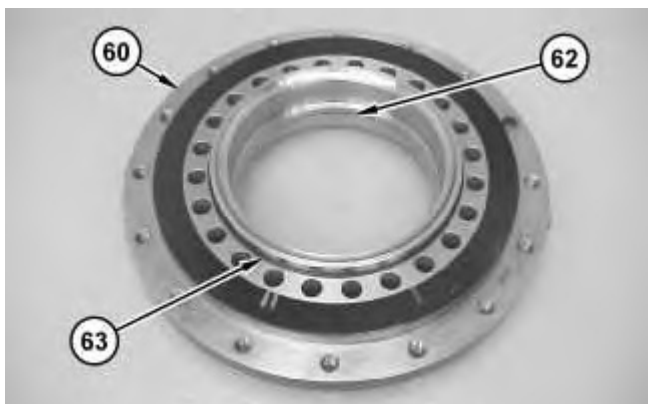

<https://www.ebooklibonline.com>

Hello dear friend!

Thank you very much for reading.

Enter the link into your browser.

The full manual is available for immediate download.

<https://www.ebooklibonline.com>